

# Farm Bars

---

*Animal Scale*

## Operation Manual



© Rice Lake Weighing Systems. All rights reserved.

Rice Lake Weighing Systems® is a registered trademark of  
Rice Lake Weighing Systems.

All other brand or product names within this publication are trademarks or  
registered trademarks of their respective companies.

All information contained within this publication is, to the best of our knowledge, complete and  
accurate at the time of publication. Rice Lake Weighing Systems reserves the right to make  
changes to the technology, features, specifications and design of the equipment without notice.

The most current version of this publication, software, firmware and all other product  
updates can be found on our website:

[www.ricelake.com](http://www.ricelake.com)

# Revision History

---

This section tracks and describes manual revisions for awareness of major updates.

Revision	Date	Description
C	February 9, 2023	Revision history established; updated calibration instructions

*Table i. Revision Letter History*



*Technical training seminars are available through Rice Lake Weighing Systems. Course descriptions and dates can be viewed at [www.ricelake.com/training](http://www.ricelake.com/training) or obtained by calling 715-234-9171 and asking for the training department.*

# Contents

---

<b>1.0 Introduction</b> .....	<b>5</b>
1.1 Safety .....	5
<b>2.0 Technical Specifications</b> .....	<b>6</b>
<b>3.0 Installation</b> .....	<b>8</b>
<b>4.0 Parts List</b> .....	<b>9</b>
<b>5.0 Maintenance</b> .....	<b>11</b>
5.1 Calibration .....	11
5.1.1 Front Panel Calibration .....	12
5.1.2 Alternative Zero Calibrations .....	13
5.1.3 EDP Command Calibration .....	13
<b>6.0 Troubleshooting</b> .....	<b>13</b>
6.1 General .....	13
6.2 Drifting .....	13
6.3 Abnormally Large Reading .....	13
<b>7.0 Load Cell Replacement</b> .....	<b>15</b>
<b>8.0 Specifications</b> .....	<b>16</b>



Rice Lake continually offers web-based video training on a growing selection of product-related topics at no cost. Visit [www.ricelake.com/webinars](http://www.ricelake.com/webinars)

# 1.0 Introduction

This manual is intended for use by individuals responsible for installing and servicing Farm Bars. Placing a set of Farm Bars beneath any platform or container allows it to function as a weigh scale. Various indicator combinations can be matched to the Farm Bar to meet specialized applications.



Manuals and additional resources are available from Rice Lake Weighing Systems at [www.ricelake.com/manuals](http://www.ricelake.com/manuals)

Warranty information is available at [www.ricelake.com/warranties](http://www.ricelake.com/warranties)

## 1.1 Safety

### Safety Definitions:



**DANGER:** Indicates an imminently hazardous situation that, if not avoided, will result in death or serious injury. Includes hazards that are exposed when guards are removed.



**WARNING:** Indicates a potentially hazardous situation that, if not avoided, could result in serious injury or death. Includes hazards that are exposed when guards are removed.



**CAUTION:** Indicates a potentially hazardous situation that, if not avoided, could result in minor or moderate injury.



**IMPORTANT:** Indicates information about procedures that, if not observed, could result in damage to equipment or corruption to and loss of data.

### General Safety



**Do not operate or work on this equipment unless this manual has been read and all instructions are understood. Failure to follow the instructions or heed the warnings could result in injury or death. Contact any Rice Lake Weighing Systems dealer for replacement manuals.**



#### **WARNING**

**Failure to heed could result in serious injury or death.**

**DO NOT allow minors (children) or inexperienced persons to operate this unit.**

**DO NOT operate without all shields and guards in place.**

**DO NOT jump on the scale.**

**DO NOT use for purposes other than weight taking.**

**DO NOT place fingers into slots or possible pinch points.**

**DO NOT use any load bearing component that is worn beyond 5% of the original dimension.**

**DO NOT use this product if any of the components are cracked.**

**DO NOT exceed the rated load limit of the unit.**

**DO NOT make alterations or modifications to the unit.**

**DO NOT remove or obscure warning labels.**

**Keep hands, feet and loose clothing away from moving parts.**

## 2.0 Technical Specifications

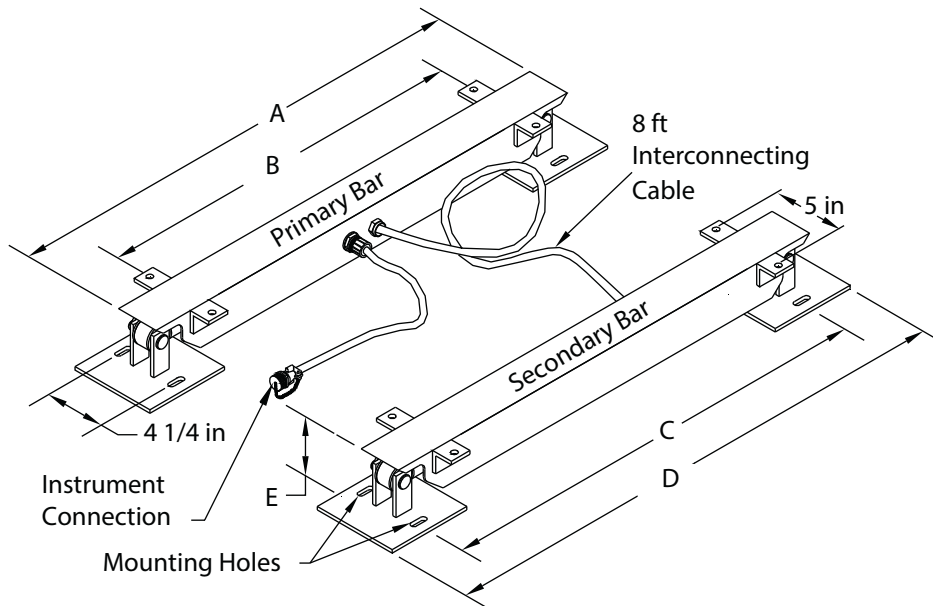

Figure 2-1. Farm Bar Dimensions

A	B	C	D	E
22.00 in	15.00 in	19.75 in	25.75 in	4.00 in

Table 2-1. Farm Bar 2,500U Dimensions

A	B	C	D	E
26.00 in	19.00 in	23.75 in	29.75 in	4.00 in
33.00 in	26.00 in	30.75 in	36.75 in	4.00 in
36.00 in	29.00 in	33.75 in	39.75 in	4.00 in
40.00 in	33.00 in	37.75 in	43.75 in	4.00 in
44.00 in	37.00 in	41.75 in	47.75 in	4.00 in
48.00 in	41.00 in	45.75 in	51.75 in	4.00 in

Table 2-2. Farm Bar 5,000U Dimensions

A	B	C	D	E
32.00 in	25.00 in	29.75 in	35.75 in	4.00 in
36.00 in	29.00 in	33.75 in	39.75 in	4.00 in
48.00 in	41.00 in	45.75 in	51.75 in	4.00 in
60.00 in	53.00 in	57.75 in	63.75 in	4.00 in
72.00 in	65.00 in	69.75 in	75.75 in	4.00 in

Table 2-3. Farm Bar 10,000U Dimensions



**NOTE:** B equals dimension A minus 7 inches.  
D equals dimension C plus 6 inches.



**IMPORTANT:** Specify spread distance if any other length is required.

Specifications	2500 U	5000 U	10000 U
Capacity	2500 lb	5000 lb	10000 lb
Nominal Output	2.5 mV/V		
Max. Excitation Voltage	+15V		
Overall Accuracy Max.	±0.25% of Capacity		
Overall Accuracy Typical	±0.10% of Capacity		
Overall Accuracy (Light Load)	±0.25% of Reading		
Compensated Temp. Range	15 to 100°F		
Operating Temp. Range	-25 to 110°F		
Overload Capacity	150% of Rated Capacity		
Shipping Weight	48 lb	69 lb	110 lb

Table 2-4. Specifications

## 3.0 Installation

---

The following points help ensure proper installation of the Farm Bars. If further assistance is required, please contact the nearest factory or dealer.



**IMPORTANT:** *When planning an outdoor location for the Farm Bars, choose a site which will allow for adequate drainage away from the scale. Immersing the load cells in water can damage the load cells and void the warranty.*

- Install the Farm Bars on a firm, level surface. The Farm Bars do not have to be installed perfectly level, but a substantial slope decreases accuracy. All weight transfer must take place through the pads at the end of each Farm Bar. Ensure there is no contact between the ground and the center of the load bar.
- Install the Farm Bars in the upright position. This allows for accurate weighing and help keeps any foreign material out of the Farm Bars.
- Do not drill into or weld onto the Farm Bars as this may cause internal structural or electrical damage. Secure the Farm Bars to the weighing platform using the mounting lugs supplied.
- Install the cable so that it is not stepped on or run over. Cable failure due to physical damage is not covered under warranty.
- When constructing the weighing platform, ensure excessive sagging does not occur. This may cause inaccuracies in weighing and could damage the cable.



## 4.0 Parts List

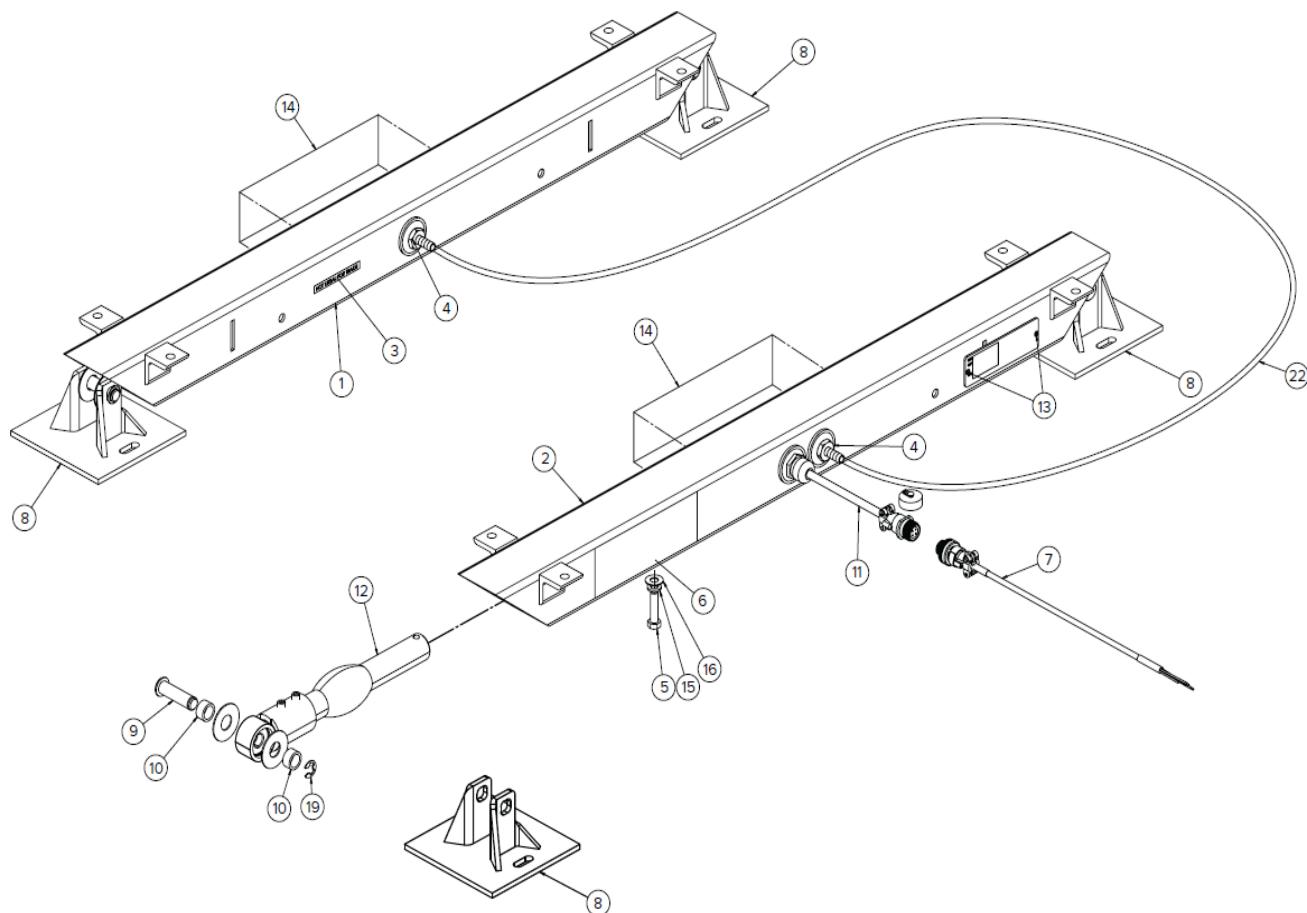

Figure 4-1. Farm Bar Illustrated Parts



**IMPORTANT:** Specify length in inches (i.e. 55206-3-33), 2500U only comes in 22" lengths.  
 Assembly includes, bearing collar, bearing, snap ring, foam seals and set screws.

Item No.	Part No.	Description
1	Consult	Farm Bar tube, one hole
2	Consult	Farm Bar tube, two holes
3	126864	Label, not Legal for Trade 3.125 x 0.375 blue on white reflective background slitback square corners loadbars
4	126893	Conn, hose barb for 3/8 ID hose x 1/2 male pipe
5	126979	3/8-16 in x 1-1/2 HCS GS 8 zinc (5,000U and 10,000U only. For 2,500U consult factory)
6	127103	Label, warranty for 5,000U scale black text on white vinyl adhesive backed
7	127556	Cable assy, 4 pin male conn 144 in for animal scale indicator
8	127770	Pad, 2,500U/5,000U/10,000U 1 KLU/2KLU/4KLU painted
9	127774	Load pin, 2,500U/5,000U/10,000U/0.1 -> 4KLU zinc plated
10	127775	Spacer, load pin 2,500U 5,000U 0.1KLU -> 2KLU zinc plated
	127796	Spacer, load pin 10,000U, Zinc plated
11	127777	Connector assy, inline w/3 ft SST flex conduit
12	127764	Load cell assembly, 2,500U
	127782	Load cell assembly, 5,000U
	127792	Load cell assembly, 10,000U
13	128136	Rivet, blind pop 1/8 dia 0.313 to 0.375 grip range AB46 aluminum steel mandrel
14	131509	Decal, load bar 2.5 x 9.5 black vinyl for livestock scale
15	15160	Washer, lock 3/8 (5,000U and 10,000U only. For 2,500U consult factory)
16	15161	Washer, flat 3/8 SST (5,000U and 10,000U only. For 2,500U consult factory)

Table 4-1. Farm Bar Parts List



**IMPORTANT: Cable length in inches (i.e. 54226-96)**

**Portable pad 54207PA-1 (Clockwise), 54207PB-2 (Counter Clockwise) direction is determined by looking down from top of the load bar and determining the direction the stop rod is pointing.**

## 5.0 Maintenance

The most common problem that occurs is a load not supported completely by the Farm Bar pads. Check around and under the weigh apparatus to see if any debris has collected near the scale. Ice, dirt, mud or manure buildup can cause inaccurate readings. Keep the scale clean to ensure proper operation.

Excess debris on top of the scale can also cause problems. Depending on the type of scale, there may be a limited range of weight that can be zeroed. Always keep material buildup on top of the scale to a minimum.

Lubricating scale bearings is also important. For bearing locations, see [Figure 5-1](#). Inject grease into the bearings using a syringe at least once every two years. Use a quality, high-pressure grease to lubricate the bearings completely. Do not use an excess of grease – it should lubricate the bearing without bleeding around the foam seal.

### 5.1 Calibration

All load cells are factory calibrated to reduce installation errors. However, regular recalibration is necessary to compensate for scale drifting. Farm Bars can be calibrated using Rice Lake's 380 Synergy Series indicator front panel or EDP commands.



**NOTE: CAL jumper must be removed to perform calibration.**

**The 380 requires a WZERO and WSPAN points to be calibrated. The linear calibration points are optional; they must fall between zero and span, but must not duplicate zero or span. Consult the 380 manual for more information.**

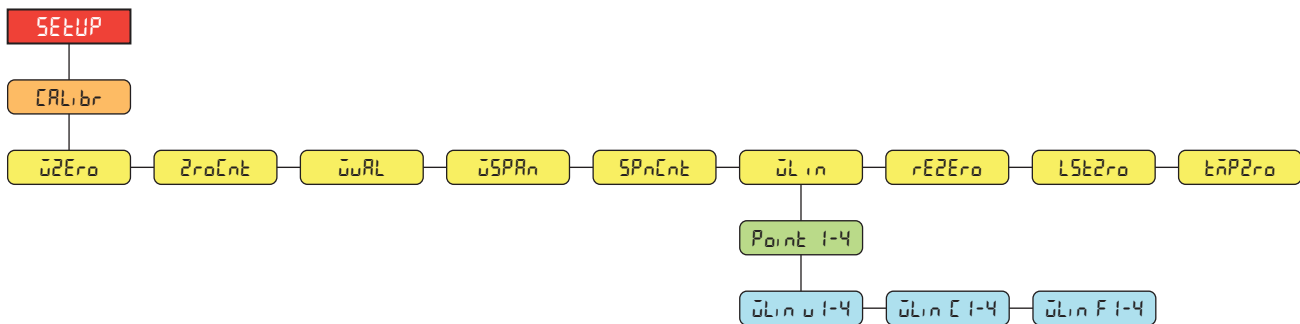



Figure 5-1. Calibration Menu

## 5.1.1 Front Panel Calibration

To calibrate the indicator using the front panel, do the following.











### 5.1.1.1 Span Calibration

Use the following steps to perform a standard span calibration on a connected scale.

1. Press  during power up to access the *SETUP* menu.









 **NOTE:** When accessing Setup mode, only press  once. Do not press and hold or double press .

**NOTE:** CAL jumper must be removed to perform calibration.

2. Press  once. *CONF* displays
3. Press  twice. *RLIB* displays.
4. Press . *ZERO* displays.
5. Ensure there is no weight on the scale.
6. Press  to perform a zero calibration. *OK* displays.
7. Press . *Zero* displays.
8. Press . *URL* displays.
9. Press . The current test weight value displays.
10. Enter a new value, if necessary.
11. Press  to accept value. *SPAN* displays.
12. Place the specified amount of test weight on the scale.
13. Press  to perform a span calibration. *OK* displays.
14. Press . *SPAN* displays.
15. Press  three times to return to weigh mode.

### 5.1.1.2 Linear Calibration

Linear calibration points provide increased scale accuracy by calibrating the indicator at up to four additional points between the zero and span calibrations.

1. Complete [steps 1–14 in Section 5.1.1.1](#).
2. Press . *Lin* displays.
3. Press . *Point 1* displays.
4. Press . *Lin u 1* displays.
5. Press . The current test weight value for point 1 displays.
6. Enter a new value, if necessary.
7. Press  to accept value. *Lin C 1* displays.
8. Place the specified amount of test weight on the scale.
9. Press  to perform a linear point calibration. *OK* displays.
10. Press . *Lin F 1* displays.
11. Press . *Point 1* displays.
12. Press . *Point 2* displays.
13. Repeat previous steps for points 2-4, if necessary.

 **NOTE:** The linear calibration for a point is saved once point is calibrated.

14. Press  three times to return to weigh mode.

## 5.1.2 Alternative Zero Calibrations

During a calibration, the zero value (wzero) can be replaced with a temporary zero (TEMPZERO) or last zero (LASTZERO). A rezero (rezero) can be done after calibration. See below for alternative zeros.

### 5.1.2.1 Last Zero

This takes the last push-button zero in the system (from weigh mode) and uses it as the new zero reference point, consequently a new span calibration must be performed. This calibration cannot be performed when calibrating a scale for the first time.

A last zero calibration is typically used on truck scales to allow a scale verification to become a calibration without removing the test weights.

### 5.1.2.2 Temporary Zero

A temporary zero calibration temporarily zeros the displayed weight of a non-empty scale. After span calibration, the difference between the temporary zero and the previously calibrated zero value is used as an offset.

A temporary zero calibration is typically used on hopper scales to calibrate the span without losing the original zero calibration.

### 5.1.2.3 Rezero

A rezero calibration removes a calibration offset when hooks or chains are required to suspend the test weights.

Once a span calibration is complete, remove the hooks or chains and the test weights from the scale. With all the weight removed, use a rezero calibration to adjust the zero and span calibration values.

## 5.1.3 EDP Command Calibration

Use the following instructions to calibrate using EDP commands.



**NOTE: The indicator must respond with OK after each step or the calibration procedure must be done again.**

For commands ending with #s, s is the scale number (1).

1. Enter setup mode.



**NOTE: CAL jumper must be removed to perform calibration.**

2. For a standard calibration, remove all weight from scale (except hooks or chains which are needed to attach weights).
3. Send the command **SC.WZERO#s** to perform a standard calibration of the zero point.
  - Send **SC.TEMPZERO#s** to perform a temporary zero calibration
  - Send **SC.LASTZERO#s** to perform a last zero calibration
4. Apply the span calibration weight to the scale.
5. Send the command **SC.WVAL#s=xxxxx**, where **xxxxx** is the value of the span calibration weight applied to the scale.
6. Send the command **SC.WSPAN#s** to calibrate the span point. Continue to [step 7](#) to calibrate additional linearization points, or proceed to [step 11](#).
7. Apply weight equal to the first linearization point to the scale.
8. Send the command **SC.WLIN.Vn#s=xxxxx**, where **n** is the linearization point number (1-4) and **xxxxx** is the exact value of the weight applied.
9. Send the command **SC.WLIN.Cn#s** to calibrate the linearization point, where **n** is the linearization point number (1-4).
10. Repeat [steps 7–9](#) for up to four total linearization points.
11. If hooks or chains were used to attach the weights, remove all weight, including the hooks and chains, and send the command **SC.REZERO#s** to remove the zero offset.
12. Send the command **KSAVEEXIT** to return to weigh mode.

## 6.0 Troubleshooting

### 6.1 General

If having trouble with the Farm Bars, perform the following procedures to diagnose the problem. First, inspect the scale for any physical damage. Take special note of the cable and connectors. Wiggle the cables and connectors while watching the indicator display. If the readout jumps while moving a cable or connector, there is likely a short or loose connection. Repair or replace the cable or connector as appropriate.

### 6.2 Drifting

If the scale readout is drifting, moisture may be present in the scale's electrical circuit. Check for moisture in any of the connectors, junction boxes or Farm Bars. Dry any location where you suspect moisture is present. If there is a location where moisture is collects frequently, seal the location with a waterproof sealant.

### 6.3 Abnormally Large Reading

If the indicator shows a very large number and the readout cannot be changed using the indicators zero adjustment, there may be a problem in the circuit. To locate this type of problem, a series of electrical resistance measurements must be made. To perform these checks, an accurate ohmmeter and a soldering iron is required.

To locate a faulty component with the ohmmeter, start by measuring pin resistance in the connector that plugs into the indicator cable (the cable that runs into the scale). The connector has four pins labelled A, B, C and D, the following chart lists the appropriate resistance readings. Remember, when measuring pin resistance the power must be **OFF**. Ensure fingers do not contact ohmmeter probes otherwise measurement may be incorrect.

Connector Markings	Resistance Readings	Load Cell #
A – C	395Ω	
B – D	350Ω	
A – B	263Ω	I
B – C	308Ω	II
C – D	308Ω	III
D – A	263Ω	V

Table 6-1. Ohmmeter Readings



**IMPORTANT:** This table is only valid at a temperature of 71.6°F (22°C). Resistance will vary slightly with temperature.

The readings in Table 6-1 should be within 5 ohms of the value shown. The readings are slightly temperature dependent and as a result will not match Table 6-1 exactly. However, all measurements should differ from the table by the same percentage. For example, if the resistance across pins D and C reads 142Ω ±1Ω, resistance across pins D and A should also read 142Ω ±1Ω. Specifically, the values equal in Table 6-1 should also be equal when you take your measurements. If the readings correspond to the values in the table, an electrical problem in the scale is not likely. If any readings across pins of the connector differ from the table, each load cell must be checked individually.

When checking an individual load cell, it must be completely disconnected from the scale's electrical circuit. To accomplish this, the wires will need to be taken apart at the Farm Bar cable splice. See Figure 6-1 for the wiring of a Farm Bar system. The circuit diagram for the load cells of a U Series Farm Bar system is shown in Figure 7-1 on page 15. Remember that each load cell contains four wires. All four wires must be disconnected to separate that load cell from the circuit.

Take apart the cable splices and measure resistance across each of the load cells. The cell resistance should be 350Ω. If the measurement for the cell is larger than 350Ω, or an open circuit, the load cell may have to be replaced. If receiving an incorrect measurement from load cells I and II in the support bar, check the cable which connects the to bars for continuity.

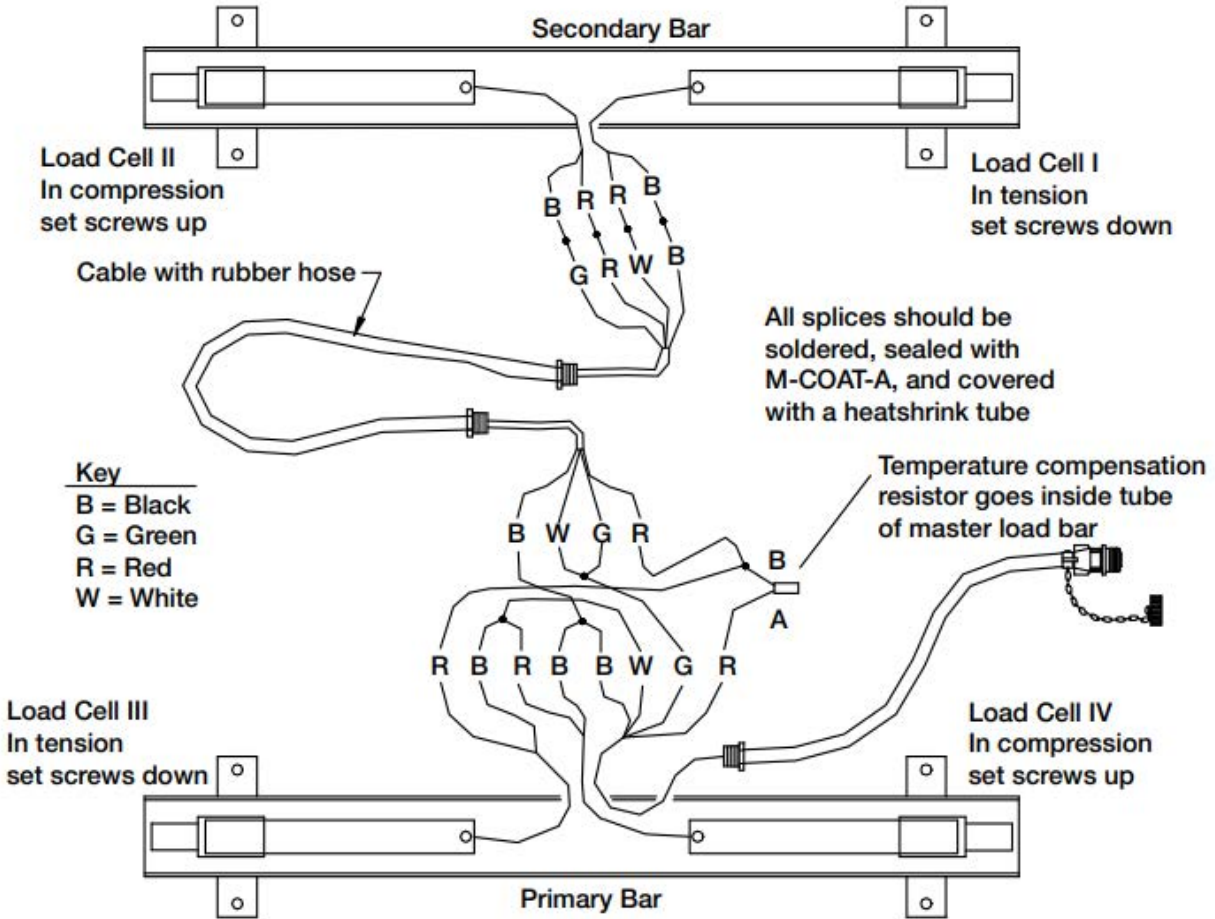

Figure 6-1. Farm Bar System Wiring Diagram

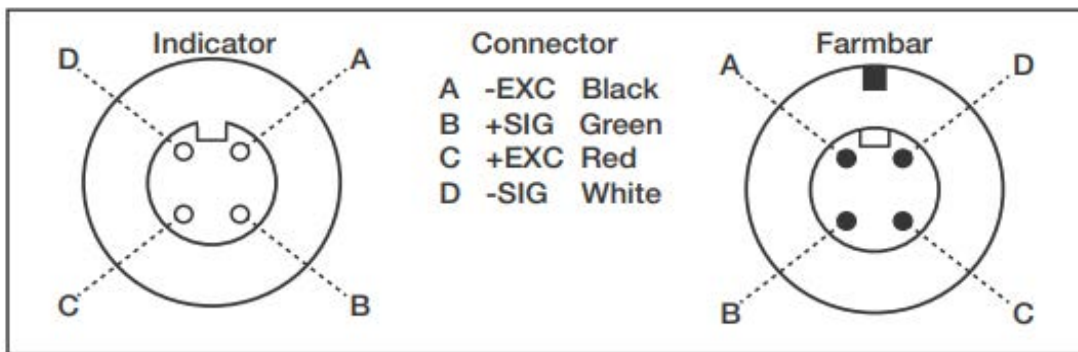

Figure 6-2. Farm Bar System Connection

## 7.0 Load Cell Replacement

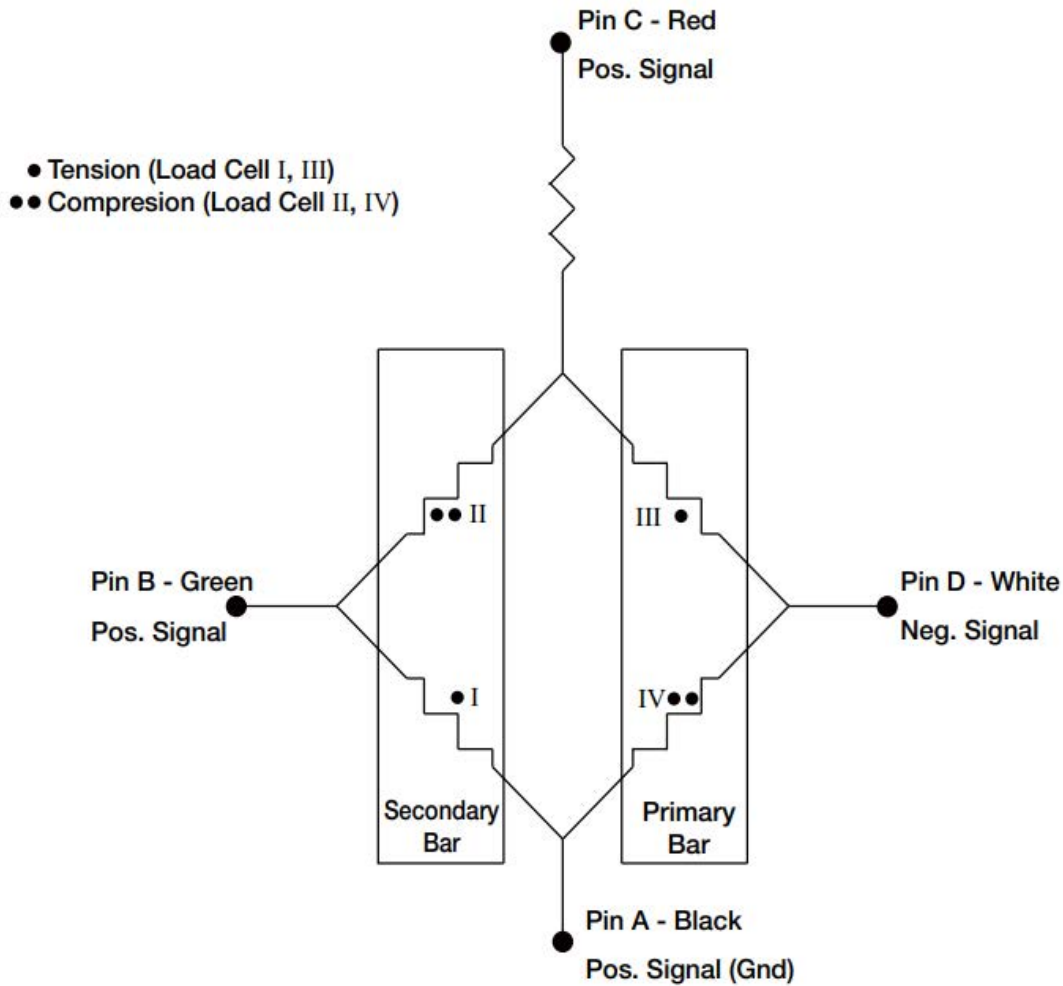

Figure 7-1. System Schematic

If load cell replacement is necessary, follow this procedure:

1. Tie string or wire around the end of the cable for the load cell being replaced. This string will be used to feed the new load cell cable through the bar and to the splicing junction.
2. Remove the mounting bolt that holds the cell in place.
3. Remove the load cell and cable with the attached string.
4. Check for physical damage to the load cell and cable. If the cable is damaged, it may be replaced by splicing it together.



**IMPORTANT:** *Figure 7-1 displays the position for the set screws that hold the bearing collars in place. The set screw positions are NOT all the same! When replacing a load cell, place it in with proper set screw orientation. If the load cell is installed upside down, the scale will not work properly.*



## 8.0 Specifications

---

Safe Overload:

150%

Full Scale Output:

3mv/V nominal

Output is standardized for each model of load bar, consult factory for details

Maximum Excitation:

15 VDC

Nonlinearity:

0.02% full scale

Hysteresis:

0.02% full scale

Bridge Resistance:

350 ohm

Temperature Range:

-40 °F to 111 °F (-40 °C to 44 °C)

Cable Configuration:

8 ft between bars and 12 ft for the indicator

Warranty:

Two-year limited







© Rice Lake Weighing Systems Content subject to change without notice.

230 W. Coleman St. • Rice Lake, WI 54868 • USA  
U.S. 800-472-6703 • Canada/Mexico 800-321-6703 • International 715-234-9171 • Europe +31 (0)26 472 1319