

iDimension® Flex Series

Pallet Dimensioning System

Assembly Manual



© Rice Lake Weighing Systems. All rights reserved.

Rice Lake Weighing Systems® is a registered trademark of
Rice Lake Weighing Systems.

All other brand or product names within this publication are trademarks or
registered trademarks of their respective companies.

All information contained within this publication is, to the best of our knowledge, complete and
accurate at the time of publication. Rice Lake Weighing Systems reserves the right to make
changes to the technology, features, specifications and design of the equipment without notice.

The most current version of this publication, software, firmware and all other product
updates can be found on our website:

www.ricelake.com

Revision History

This section tracks and describes manual revisions for awareness of major updates.

Revision	Date	Description
A	October 20, 2023	Initial Release
B	January 3, 2024	Added kiosk mounting instructions

Table i. Revision Letter History



Technical training seminars are available through Rice Lake Weighing Systems. Course descriptions and dates can be viewed at www.ricelake.com/training or obtained by calling 715-234-9171 and asking for the training department.

Contents

1.0	Introduction	5
1.1	Companion Manuals	5
1.2	Safety	6
1.3	Dimensions	7
1.3.1	Free Standing Flex Dimensions	7
1.3.2	Suspended Flex Dimensions	7
2.0	Replacement Parts	8
2.1	Free Standing Flex	8
2.2	Suspended iDimension Flex Assembly	10
2.3	Common Parts	11
3.0	Free Standing Frame Assembly	12
3.1	Introduction	12
3.1.1	Upright Pivoting Assembly Steps	12
3.1.2	Forklift Assist Assembly Steps	12
3.1.3	Parts	12
3.1.4	Roll-in T-nut	13
3.2	First Assembly Steps	13
3.2.1	Floor Mount Assembly	13
3.2.2	Mount Sensor Shrouds	14
3.2.3	T-Mount Bars	14
3.3	Upright Pivoting Frame Assembly	15
3.3.1	Assemble T-Mount Side Frames	15
3.3.2	Assemble Horizontal Connecting Bars	16
3.4	Forklift Assist Assembly	18
3.4.1	Assemble Top	18
3.4.2	Lift Top of Frame	19
3.5	Align Sensor Shrouds	20
3.6	Mount J-box	20
4.0	Suspended Flex Assembly	21
5.0	Accessories and Wiring	23
5.1	Sensors	23
5.2	J-Box	25
5.3	Kiosk	27
5.3.1	Kiosk Wiring	27
5.3.2	Optional Kiosk Stand	29
5.3.3	Optional Kiosk Mount	30
5.4	IP Camera (PN 200168)	31



Rice Lake continually offers web-based video training on a growing selection of product-related topics at no cost. Visit www.ricelake.com/webinars

1.0 Introduction

This manual provides an overview of the iDimension Flex Series assembly instructions. It includes assembly instructions for both the Free Standing Flex Dimensioning System and the Suspended Flex Dimensioning System.

When interfacing this device to a third party program, refer to the software manufacturer's documentation for setup and configuration information.



Manuals are available from Rice Lake Weighing Systems at www.ricelake.com/manuals

Warranty information is available at www.ricelake.com/warranties

1.1 Companion Manuals

iDimension QubeVu Administrator Guide

The QubeVu® Administrator Guide (PN 221652) provides an overview to configure the QubeVu Manager software.

iDimension Ceiling Mount Installation Addendums

The Suspended Flex Dimensioning System must be mounted to an iDimension mounting frame. The mounting frame either uses an 80/20 bar system or a suspended cable system. See one of the following addendums for more information on installing the applicable iDimension Flex mounting system:

- iDimension LTL/LTL-XL/Flex 80/20 Mounting Frame Installation Addendum (PN 221406)
- iDimension LTL/LTL-XL/Flex Cable Mounting Frame Installation Addendum (PN 221407)

1.2 Safety

Safety Definitions:



DANGER: Indicates an imminently hazardous situation that, if not avoided, will result in death or serious injury. Includes hazards that are exposed when guards are removed.



WARNING: Indicates a potentially hazardous situation that, if not avoided, could result in serious injury or death. Includes hazards that are exposed when guards are removed.



CAUTION: Indicates a potentially hazardous situation that, if not avoided, could result in minor or moderate injury.



IMPORTANT: Indicates information about procedures that, if not observed, could result in damage to equipment or corruption to and loss of data.

General Safety



Do not operate or work on this equipment unless this manual has been read and all instructions are understood. Failure to follow the instructions or heed the warnings could result in injury or death. Contact any Rice Lake Weighing Systems dealer for replacement manuals.



WARNING

Failure to heed could result in serious injury or death.

Electric shock hazard!

There are no user serviceable parts. Refer to qualified service personnel for service.

The unit has no power switch. To completely remove power from the unit, disconnect the power source at the AC outlet.

For pluggable equipment, the socket outlet must be installed near the equipment and must be easily accessible.

When cycling power, use the in-line power cord at a power outlet.

Always disconnect from main power before performing any work on the device.

Do not allow minors (children) or inexperienced persons to operate this unit.

Do not place fingers into slots or possible pinch points.

Do not use this product if any of the components are cracked.

Do not make alterations or modifications to the unit.

Do not remove or obscure warning labels.

Do not use near water. Avoid contact with excessive moisture.

Retain packaging. When transporting the unit, always disassemble and pack it in its original packaging.

Operate between 41–104° F (5–40° C).

Never modify or attempt to repair the unit. Service must be performed by Rice Lake Weighing Systems only.

Handle cables and cable connectors with care. Never use damaged power cords or plugs or loose electrical sockets. Never touch the power cord with wet hands.

Mount on a flat surface.

Follow OSHA regulations for installation and use of equipment.

1.3 Dimensions

1.3.1 Free Standing Flex Dimensions

Overall dimensions of the four sensor floor mounted assembly and the two sensor floor mounted assembly are similar.

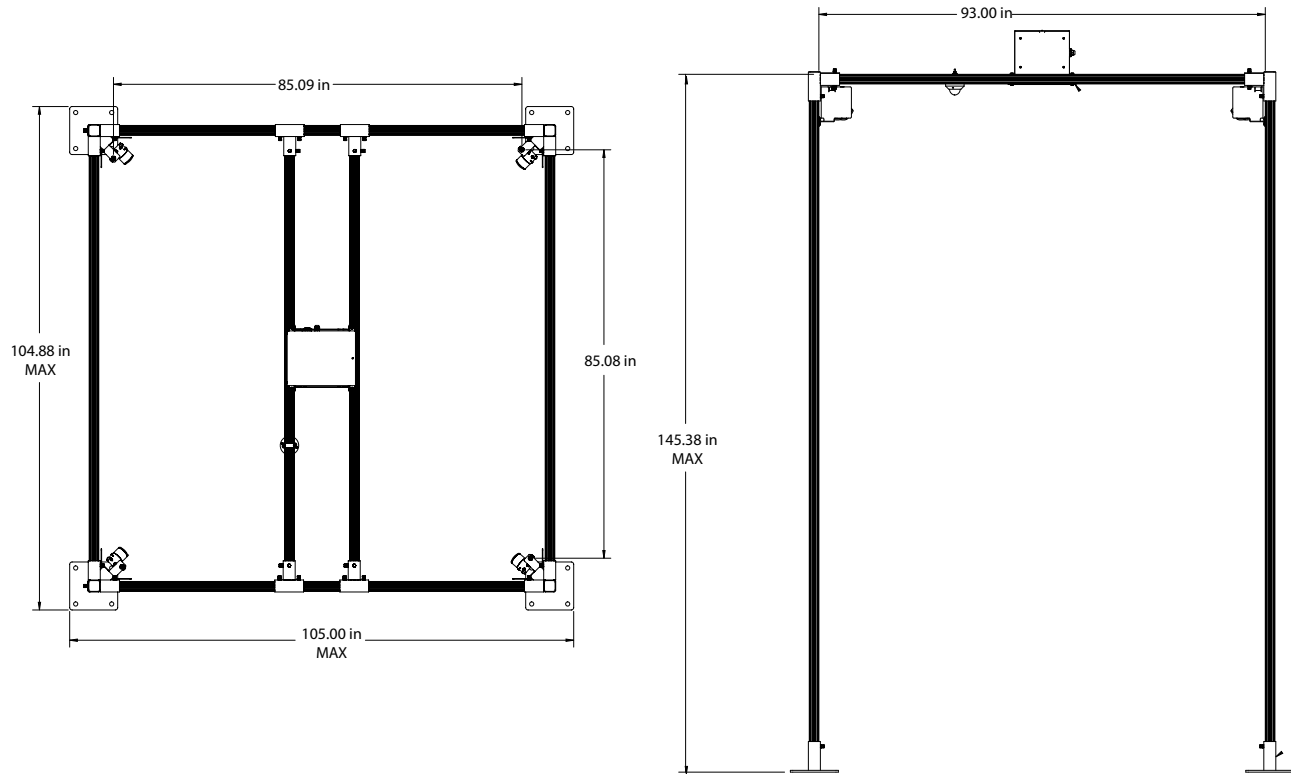

Figure 1-1. iDimension Free Standing Flex Dimensions

1.3.2 Suspended Flex Dimensions

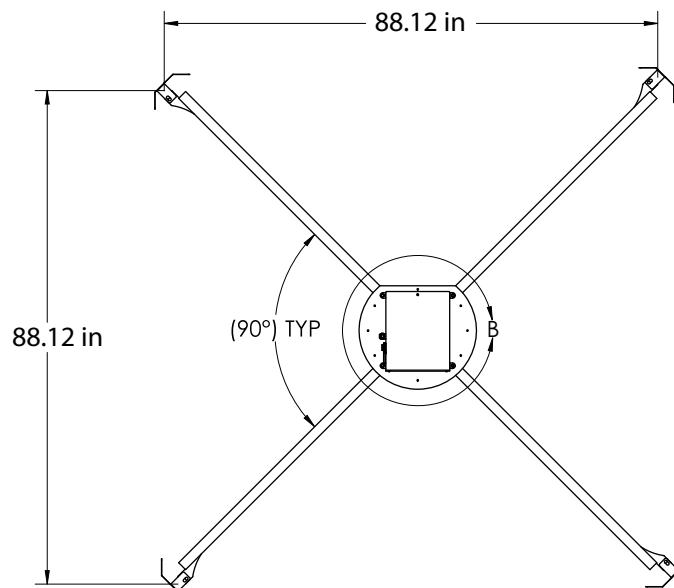

Figure 1-2. iDimension Suspended Flex Dimensions

2.0 Replacement Parts

This section provides an overview of replacement parts for the iDimension Flex Series.

2.1 Free Standing Flex

Immediately after unpacking the Free Standing iDimension Flex, visually inspect the contents to ensure all components are included and undamaged. If any parts were damaged in shipment, notify Rice Lake Weighing Systems and the carrier immediately.

The Free Standing iDimension Flex is packaged with the following parts:

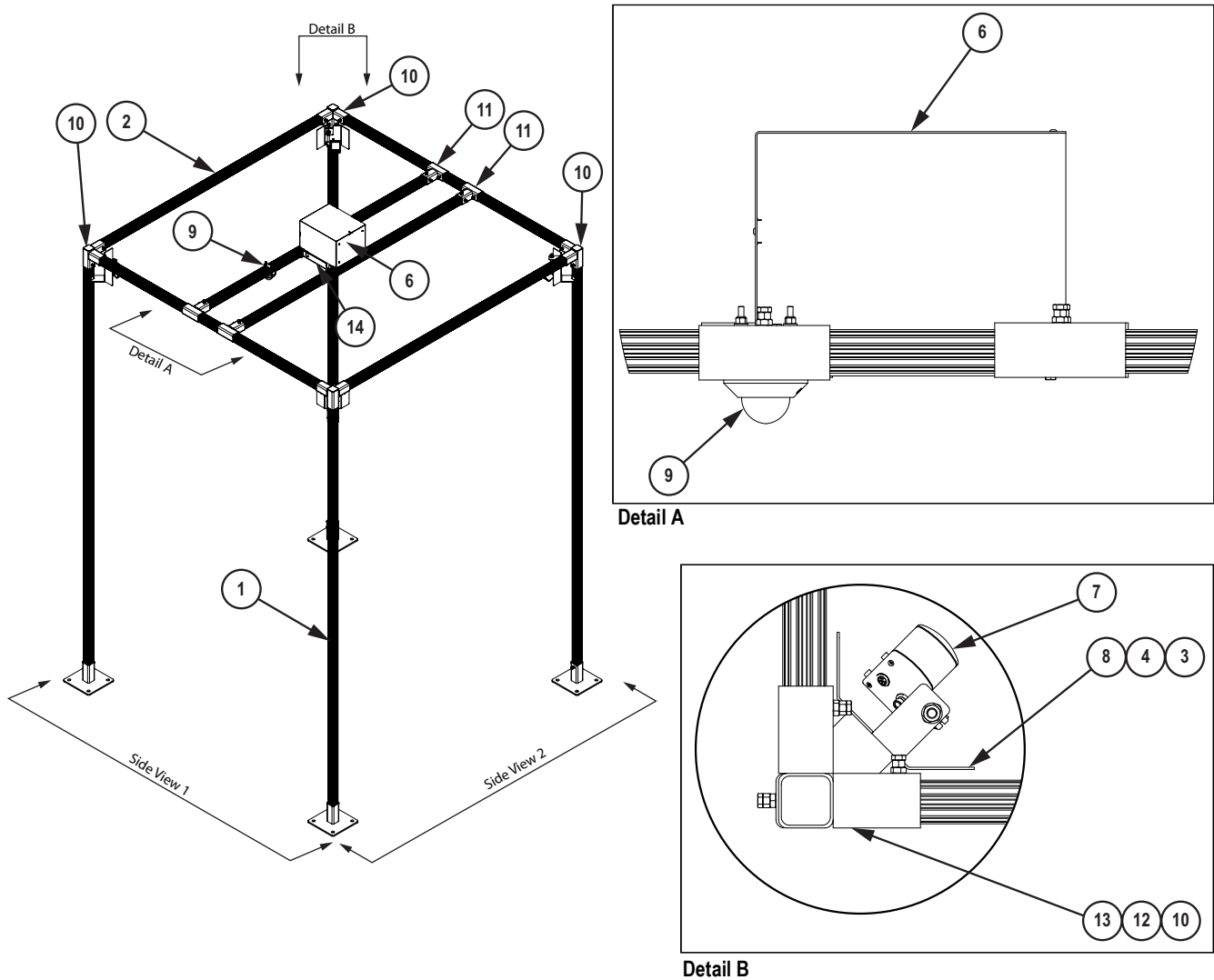

Figure 2-1. Free Standing iDimension Flex Parts

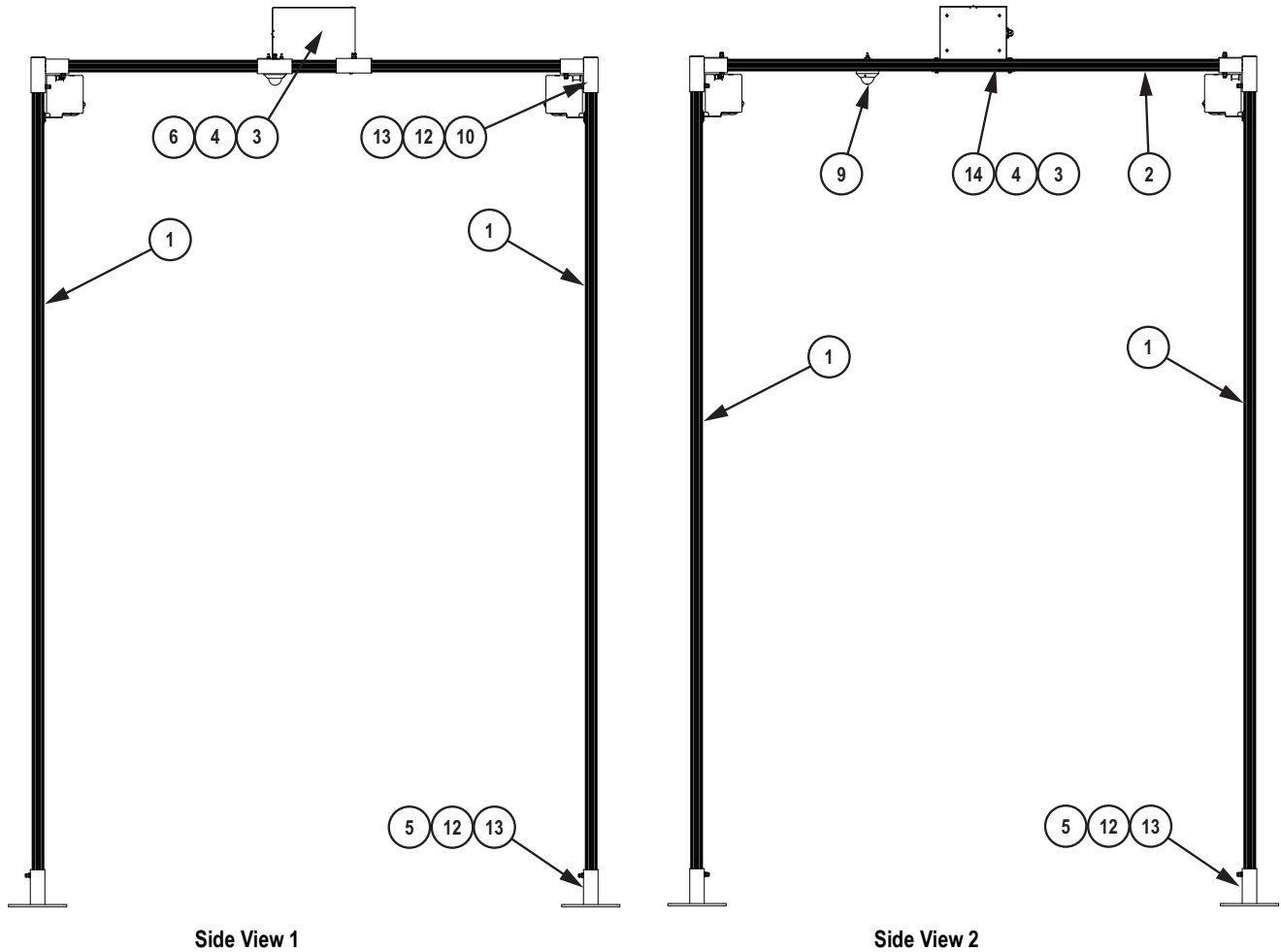

Figure 2-2. Free Standing iDimension Flex Parts

Item No.	Part No.	Description	Qty.
1	219534	Extruded Aluminum, 2 x 2 slotted aluminum red 2020 Series 80/20, 145 in LG	4
2	214421	Extruded Aluminum, 2 x 2 slotted aluminum red 2020 Series 80/20, 93 in LG	6
3	202320	T-Nut, Roll-in 1/4 - 20 NC x 1/2 hex head fully threaded A307 bolt grade 2 steel clear zinc plated	24
4	14955	Screw, Cap 1/4 - 20 NC x 1/2 hex head fully threaded Grade A steel clear zinc plated	24
5	215639	80/20 tube upright floor mount 3/8 - 16 weld nuts, MS	4
6	202141	J-Box, iDim PWD/Flex Mounted on top of sensor assembly, switch, POE and terminals.	1
7	200164	Remote sensor kit, iDim 4 remote sensors and mounting hardware, firmware installed (Table 2-3 on page 11)	1
8	214415	Corner iDim sensor mount and shield weldment, black, MS	4
9	200168	iDim Flex Camera Kit option including camera, cabling and hardware	1
10	215636	80/20 capped corner connection weldment, 3/8 - 16 weld nuts, MS	4
11	215635	80/20 T-connection weldment, 3/8 - 16 weld nuts, MS	4
12	132684	Nut, 3/8 - 16 NC Steel Zinc Plated, Grade 5	48
13	170550	Bolt, HEX 3/8 - 16NC x 1 Grade 5 steel zinc plated	48
14	220076	Bottom plate, Flex j-box, 5th sensor mount	1
15	186371	Mount rod, iDim400 Plus	4

Table 2-1. Free Standing iDimension Flex Parts List

2.2 Suspended iDimension Flex Assembly

Immediately after unpacking the Suspended iDimension Flex, visually inspect the contents to ensure all components are included and undamaged. If any parts were damaged in shipment, notify Rice Lake Weighing Systems and the shipper immediately.

The Suspended iDimension Flex is packaged with the following parts:

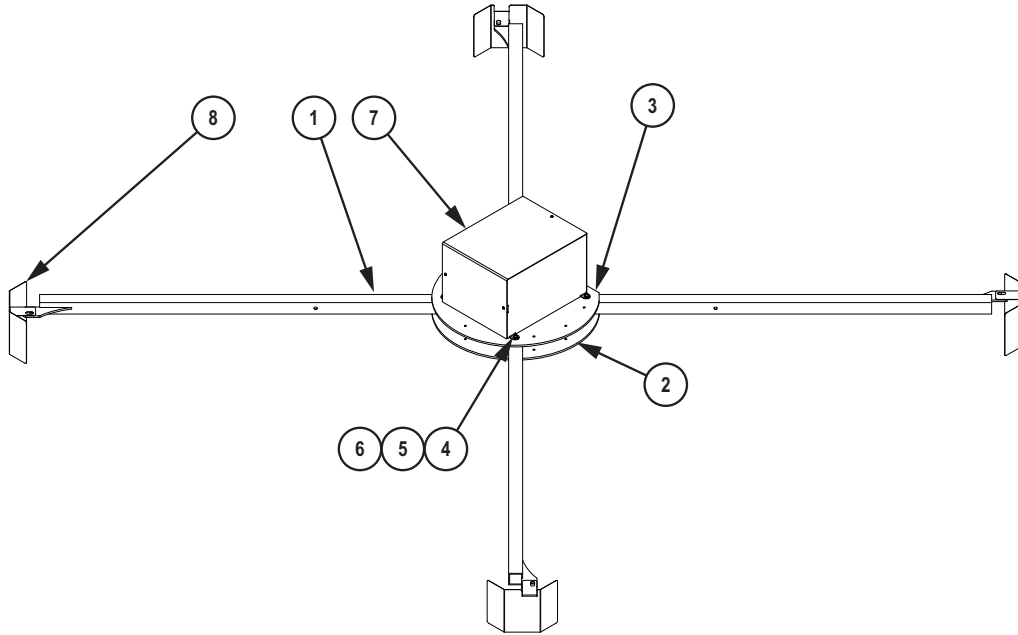

Figure 2-3. Suspended iDimension Flex Assembly Parts

Item No.	Part No.	Description	Qty.
1	199615	PWD/Flex Sensor Assembly, Sensor Arms	4
2	199614	PWD/Flex Sensor Assembly, Hub Bottom Plate	1
3	199613	PWD/Flex Sensor Assembly, Hub Top Plate	1
4	15145	Washer, plain 1/4 type A series N steel zinc plated	16
5	199629	Screw, cap 1/4-20 X 3 hex head partially threaded grade 5 zinc finish	8
6	14635	Nut, Lock 1/4-20NC HEX Nylon insert steel zinc plated	8
7	202141	J-box, iDim PWD/Flex mounted on top of sensor assembly, witch, POE, and terminals	1
8	199619	PWD sensor shroud shield	4
	200168	iDim Flex Camera Kit option including camera, cabling and hardware	1
	186371	Mount rod, iDim400 Plus	4
	200164	Remote sensor kit, iDimPWD, 4 remote sensors and mounting hardware, firmware installed	1
	219193	Kiosk, iDim Flex, Assembled and wired enclosure with QubeVu PC and HMI Panel PC	1

Table 2-2. Suspended iDimension Flex Assembly Parts List

2.3 Common Parts

Remote Sensor Kits

See [Figure 5.1 on page 23](#) for installation instructions.

Part No.	Description	Qty.
186370	Heat Sink, iDim LTL/PWD IFM Sensor	1
187199	Mnt Bracket, iDim 400 Plus Sensor	4
194731	Screw, Cap M5-0.8x80 Socket Head Cap 18-8 SST	2
195405	Remote Sensor, iDimLTL L1 Labelled 1	1
195406	Remote Sensor, iDimLTL L2 Labelled 2	1
195407	Remote Sensor, iDimLTL L3 Labelled 3	1
195408	Remote Sensor, iDimLTL L4 Labelled 4	1

Table 2-3. Four Remote Sensor Kit Parts List (PN 200164)

Calibration Kit

See the QubeVu Managers Guide (PN 198680) for calibration instructions.

Part No.	Description	Qty.
167940	Calibration Object, iDimension, 6 x 7 board with 140mm squares	1

Table 2-4. Calibration Kit Parts List (PN 167963)

3.0 Free Standing Frame Assembly

This section provides an overview of Free Standing iDimension Flex assembly procedure.

3.1 Introduction

The Free Standing iDimension Flex Frame can be assembled in one of two ways.

3.1.1 Upright Pivoting Assembly Steps

The upright pivoting assembly process assembles the sides of the frame at ground level. The sides are held upright while the short bars are inserted into the T-mount connectors. To assemble the free standing frame with the upright pivoting method, follow the steps below:

1. First Assembly Steps - [Section 3.2 on page 13](#)
2. Upright Pivoting Frame Assembly - [Section 3.3 on page 15](#)
3. Align Sensor Shrouds - [Section 3.5 on page 20](#)
4. Mount J-box - [Section 3.6 on page 20](#)

3.1.2 Forklift Assist Assembly Steps

The forklift assist assembly process assembles the top of the frame at ground level. The top is then lifted with a forklift and the legs are inserted into the frame. To assemble the free standing frame with forklift assist follow the steps below:

1. First Assembly Steps - [Section 3.2 on page 13](#)
2. Forklift Assist Assembly - [Section 3.4 on page 18](#)
3. Align Sensor Shrouds - [Section 3.5 on page 20](#)
4. Mount J-box - [Section 3.6 on page 20](#)

3.1.3 Parts

The parts in Section 3.0 correspond to the numbers in [Figure 3-1](#) and [Table 2-1 on page 9](#).

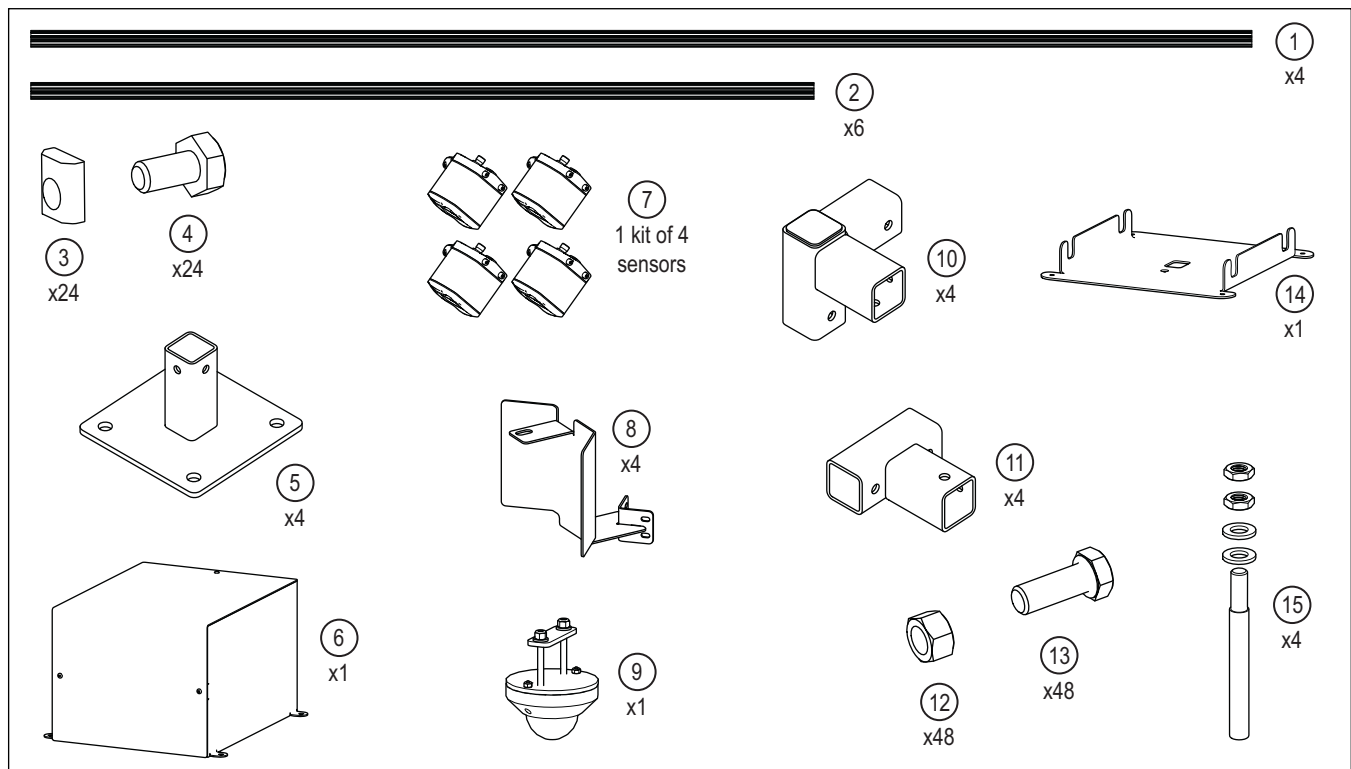

Figure 3-1. Parts Inventory

3.1.4 Roll-in T-nut

Roll-in T-nuts are inserted into the channel of the 80/20 bar to bolt accessories to the bar.

1. Insert the T-nut into 80/20 channel at an angle.
2. Rotate nut into the 80/20 channel.
3. Seat T-nut into channel.
4. Fasten bolt into T-nut to secure accessory to the bar.

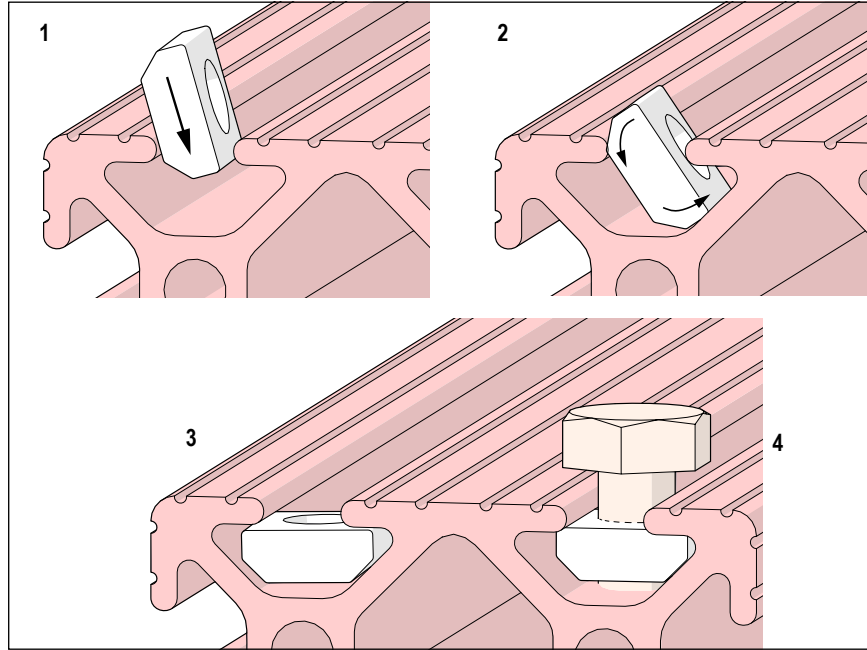

Figure 3-2. Roll-in T-bolts

3.2 First Assembly Steps

Perform first assembly steps for all methods of assembly.

3.2.1 Floor Mount Assembly

Attach one of the four floor mounts to one of the four, longer 80/20 bars.

1. Slide the end of a long 80/20 bar (Pt.1) into the floor mount (Pt.5).
2. Tighten the bolts (Pt.13 and Pt.12) in the floor mount.
3. Perform procedure for all four floor mounts.

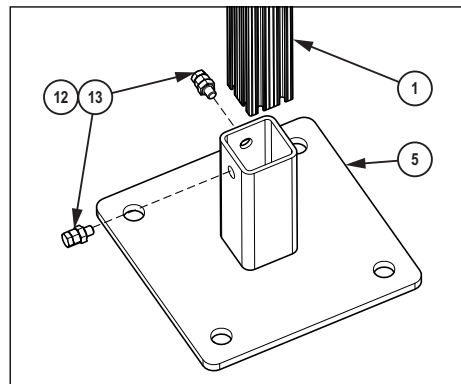

Figure 3-3. Floor Mount Installation

3.2.2 Mount Sensor Shrouds

Attach one of the four sensor shrouds (Pt.8) to one of the four vertical 80/20 bars (Pt.1).

1. Insert roll-in t-nuts (Pt.3) into the 80/20 channels as in [Section 3.1.4 on page 13](#).
2. Loosely attach the shroud (Pt.8) to the 80/20 bar with the bolts (Pt.3) and roll-in t-nuts (Pt.2).
3. Slide the shroud to the center of the bar.
4. Perform procedure for four sensor shrouds.

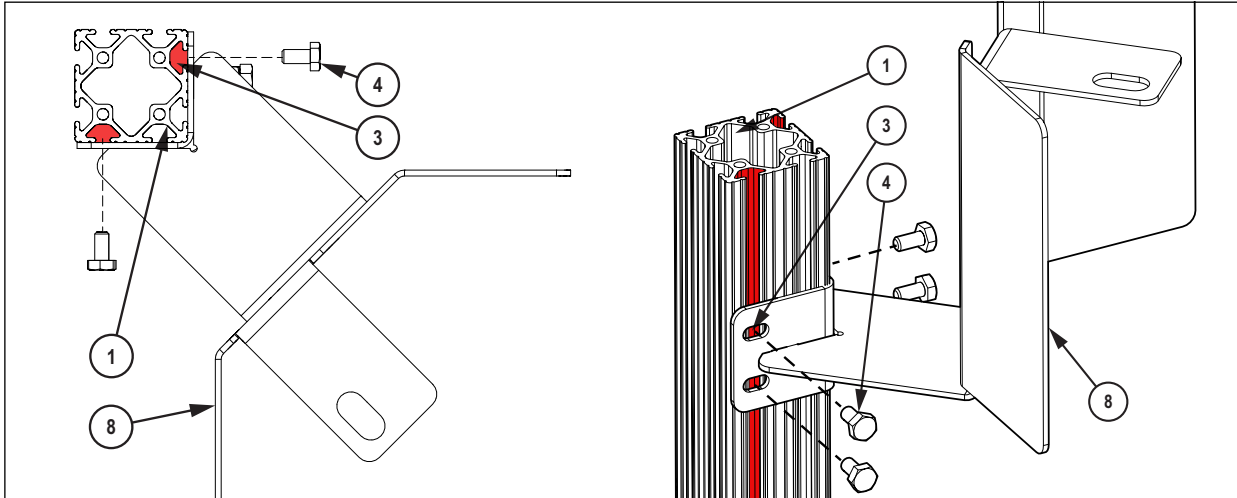

Figure 3-4. Sensor Shroud Installation

3.2.3 T-Mount Bars

Attach two T-mount connectors and two three-way connectors to two of the short, red 80/20 bars.

1. Slide two T-mounts (Pt.11) onto a short, red 80/20 bar (Pt.2).
2. Center the T-mounts on the bar 11 inches apart from t-extension to t-extension.
3. Tighten bolts to secure position.
4. Slide the 3-way connector (Pt.10) onto the ends of the 80/20 bars.
5. Perform procedure for two short bars.

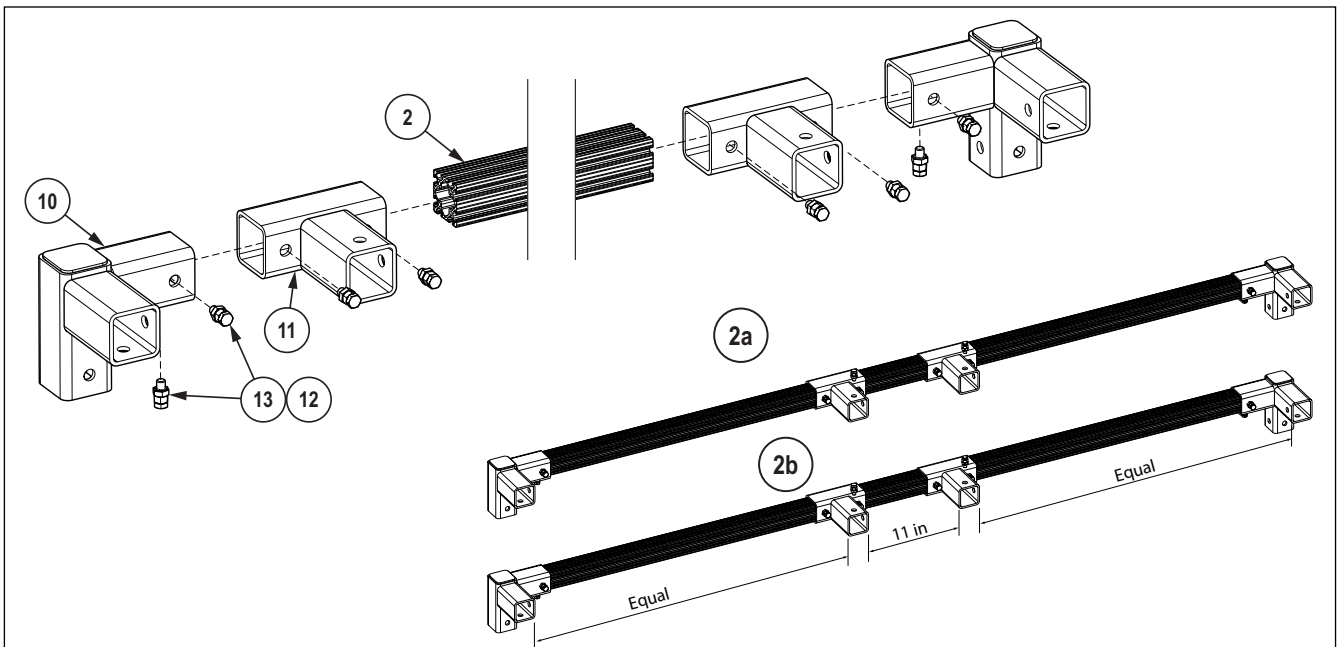

Figure 3-5. T-Mount Bar Installation

3.3 Upright Pivoting Frame Assembly

To assemble the free standing frame by the upright pivoting method, follow all steps in [Section 3.2 on page 13](#) then follow the procedures below.

3.3.1 Assemble T-Mount Side Frames

Attach two long bars (Pt.1) to each of the two three-way connectors on the short 80/20 bars assembled in [Section 3.2.3 on page 14](#).

1. Lay T-mount bar down so that T-mounts face upward.
2. Lay long bars (Pt.1) down.
3. Attach one long bar to each three-way connector (Pt.10) as in [Figure 3-6](#).



NOTE: Position sensor shrouds to face the same direction as the elbow of the three-way connector.

4. Tighten bolts to secure position.
5. Perform procedure for both assembled T-mount bars.

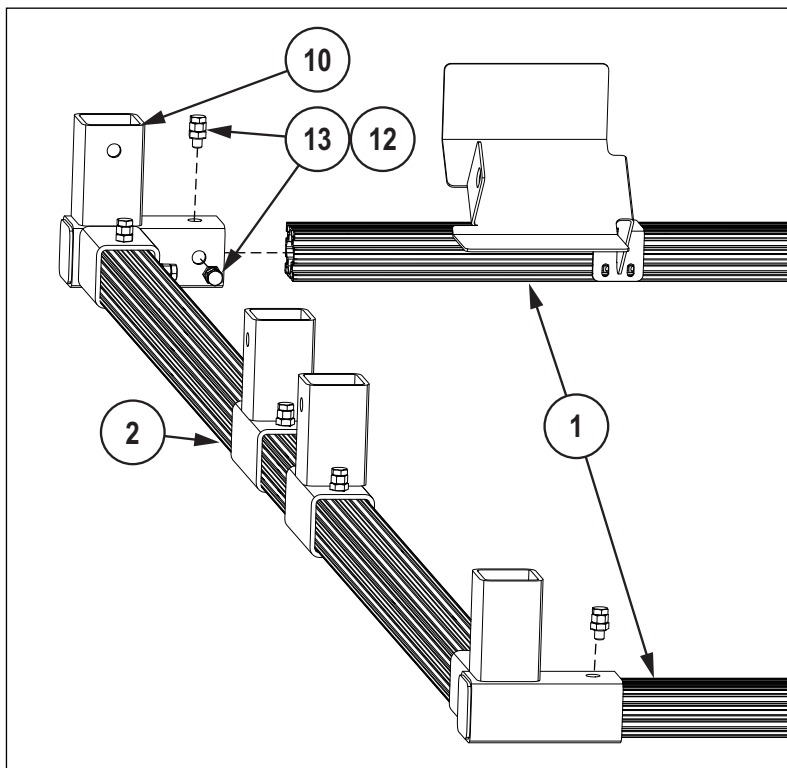

Figure 3-6. T-Mount Side Frame Installation

3.3.2 Assemble Horizontal Connecting Bars

1. Carefully stand up the side frames that were assembled in [Section 3.3.1 on page 15](#).



WARNING: Lift each u-frame with 2-3 people. If u-frames are unstable once upright, use a person at each vertical bar to support the u-frames during assembly. Use PPE such as hard hats to avoid injury during assembly.

2. Space u-frames apart by approximately the length of the short 80/20 bar (Pt.2) apart.
3. Position two ladders next to the u-frames.

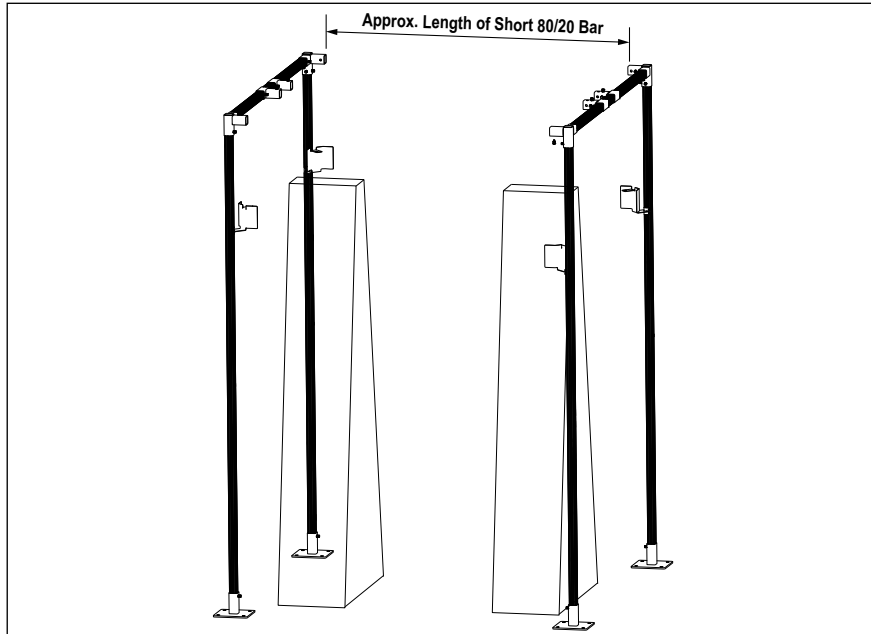

Figure 3-7. Set-up Side Frames

4. Fully insert short bar 2c into three-way connector 10a.
5. Securely bolt short bar 2c into three-way connector 10a.
6. Insert the second side of short bar 2c about 1.5 in into three-way connector 10c.
7. Screw bottom bolt into three way connector 10c so that the short bar is secured in place, but has limited ability to pivot the joint slightly wider than 90 degrees.

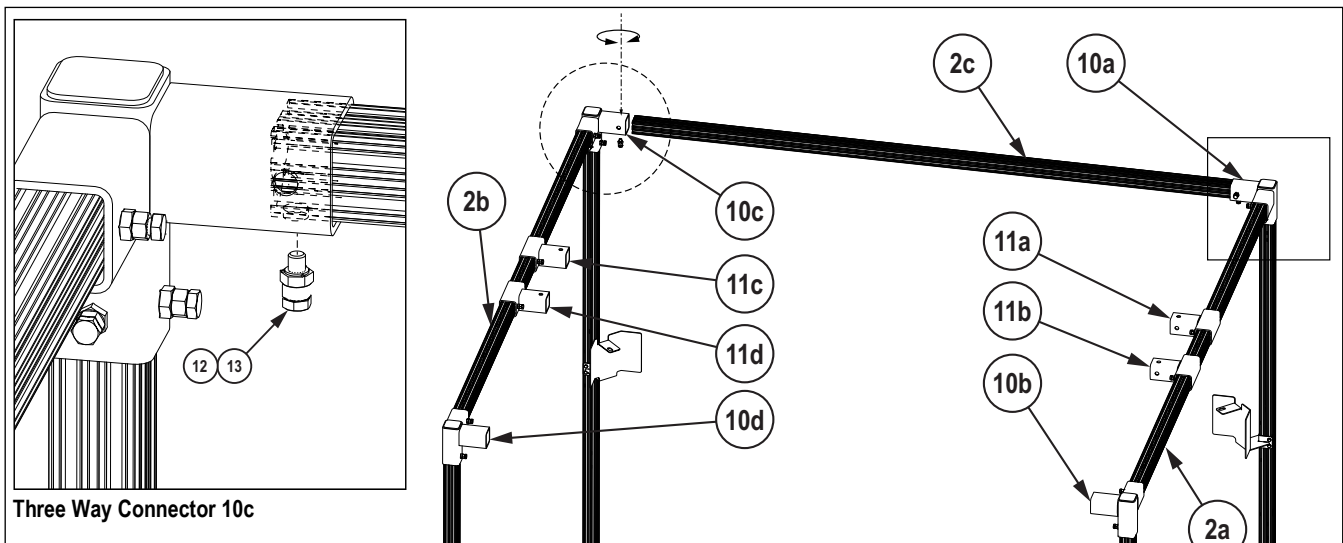

Figure 3-8. Install First Short Bar

8. Fully insert short bars 2d, 2e and 2f into T-mount 11a, T-mount 11b and three-way connector 10b.
9. Tighten bolts on T-mount 11a, T-mount 11b and three-way connector 10b onto short bars 2d, 2e and 2f.

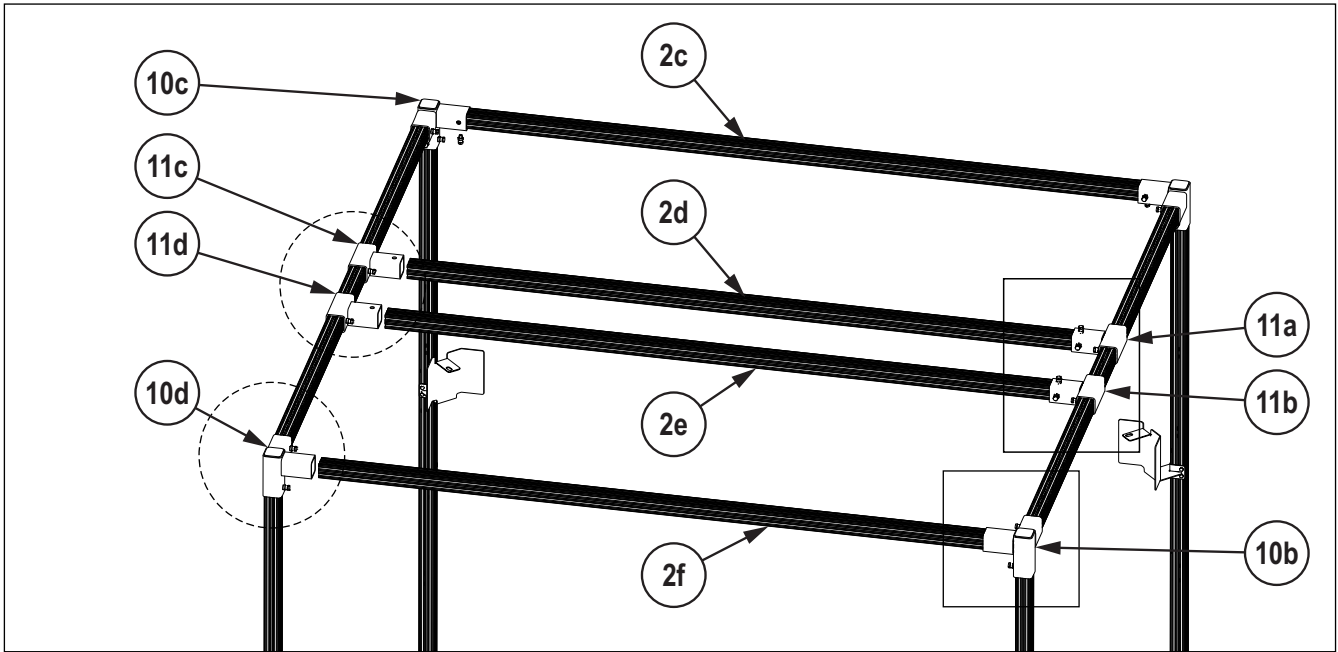

Figure 3-9. Install short Bars

10. Align and insert short bars 2d, 2e and 2f into T-mount 11c, T-mount 11d and three-way connector 10d.
11. Loosen the bolt that connects three-way connector 10c to short bar 2c. (Bolt was inserted in [Step 7 on page 16](#))
12. Seat all of the short bars fully into the connectors using a rubber mallet.
13. Tighten all bolts.

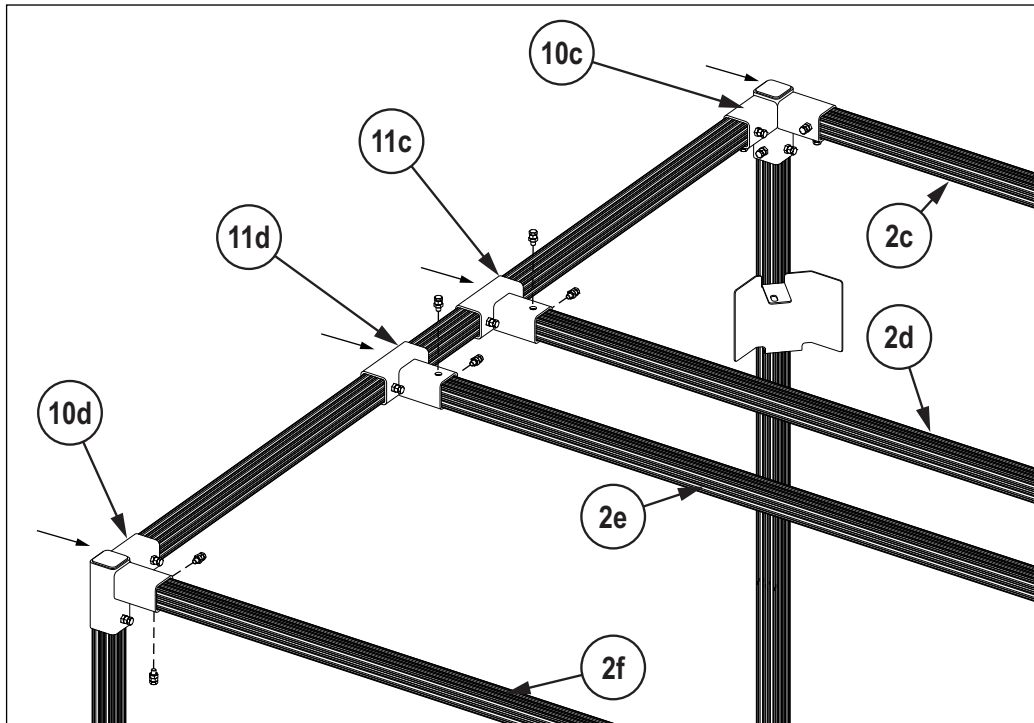

Figure 3-10. T-Mount Bar Installation

3.4 Forklift Assist Assembly

To assemble the Free Standing iDimension Flex with a forklift assist, follow [Section 3.2 on page 13](#) before the procedures in this section.

3.4.1 Assemble Top

Attach short 80/20 bars to T-mount bars assembled in [Section 3.2.3 on page 14](#).

1. Space T-mount bars 2a and 2b approximately the length of the short 80/20 bar apart.
2. Insert short bars 2c, 2d, 2e and 2f into connectors on side 2a as in [Figure 3-11](#).
3. Tighten bolts on all connectors.
4. Insert short bars 2c, 2d, 2e and 2f into connectors on side 2b as in [Figure 3-11](#).
5. Tighten bolts on all connectors.

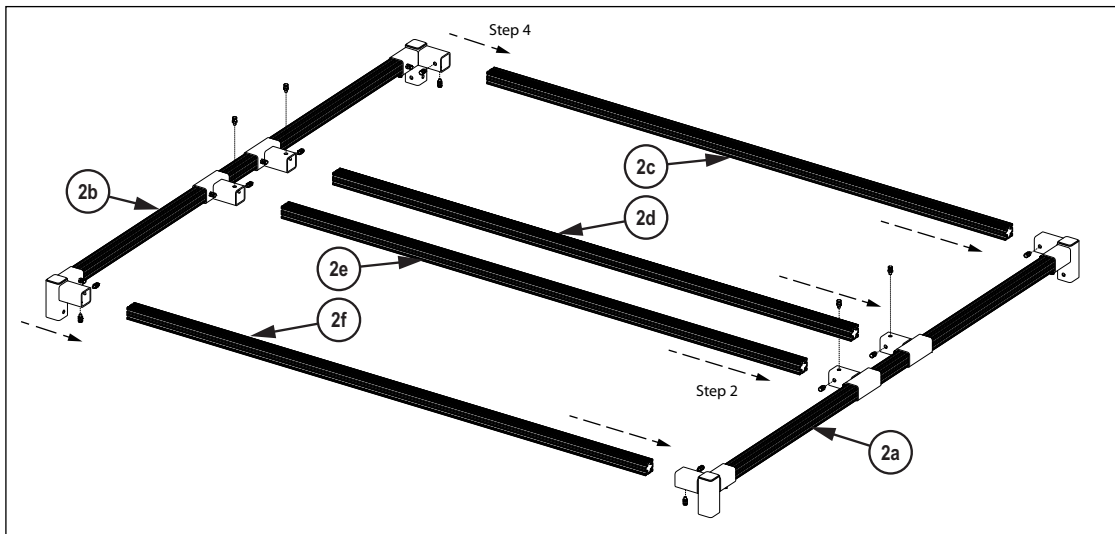

Figure 3-11. Frame Top Installation

3.4.2 Lift Top of Frame

1. Stand frame legs adjacent to the assembled top of frame.
2. Center tines of a forklift under the top of frame and secure frame to tines.



CAUTION: Frame must be secured to forklift tines to prevent frame from falling.

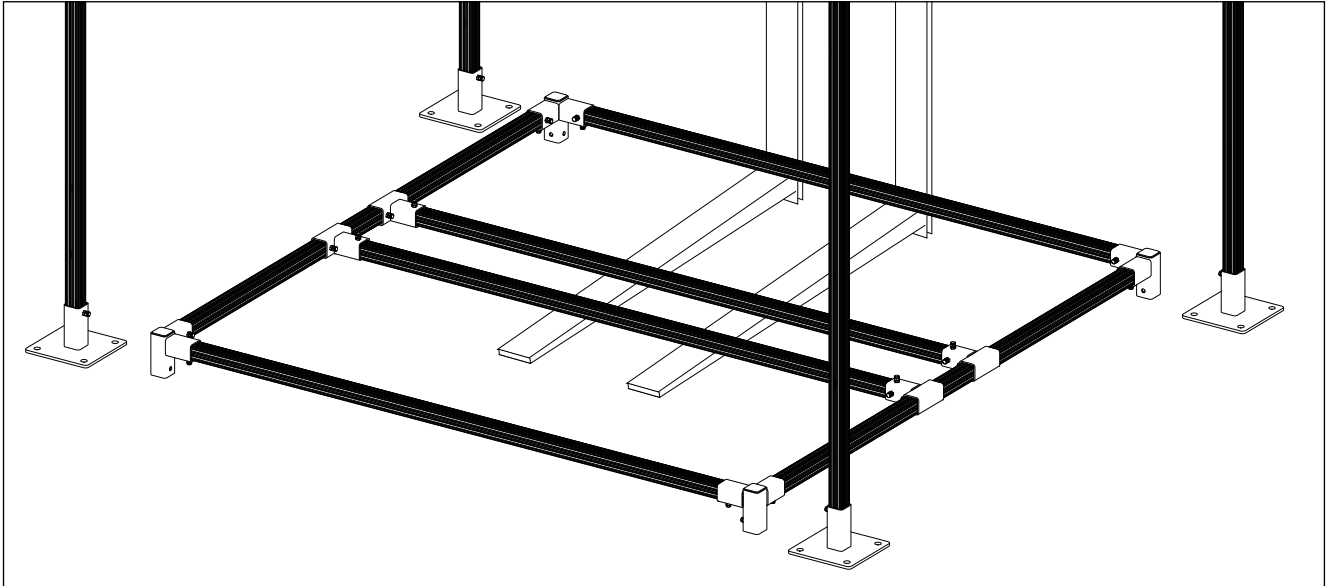

Figure 3-12. Set Legs Next to Top of Frame

3. Lift the top of frame with the forklift tines until the 3-way connectors are slightly below the height of the legs.
4. Tilt long 80/20 bar (Pt.1) up and slide under the 3-way connectors.



NOTE: Position frame legs so sensor shrouds face the center of the assembly. Forklift angle may need to be adjusted to insert bars into 3-way connectors.

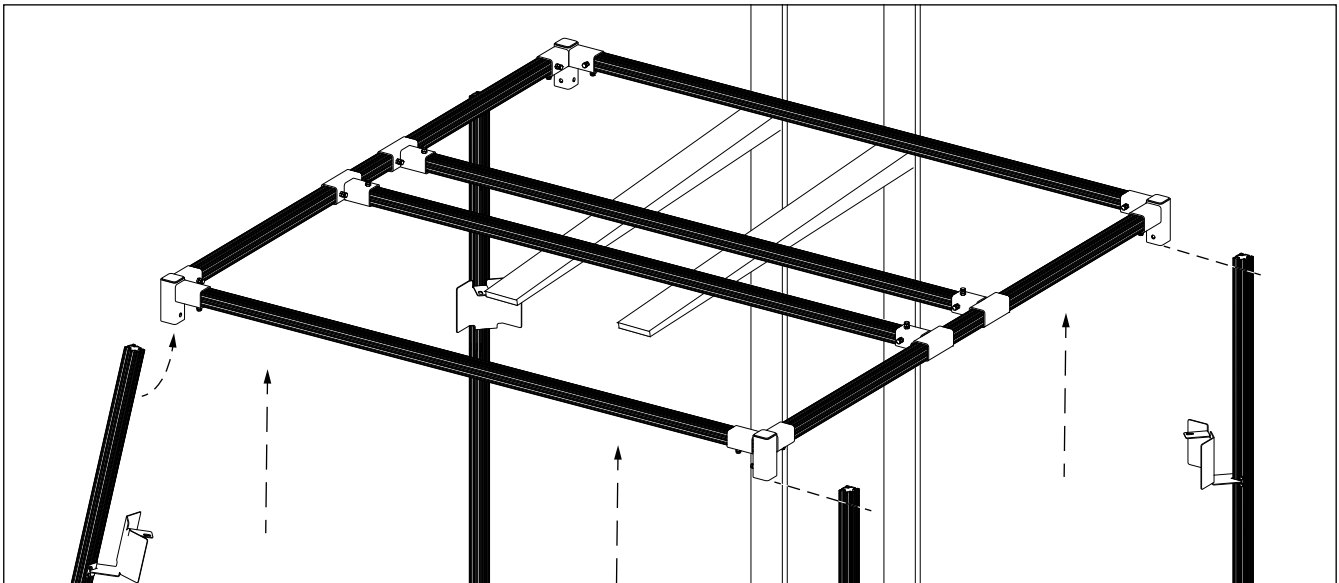

Figure 3-13. Lift Top of Frame and Align Legs

5. Lower top of frame to fully seat the connectors onto the legs.



NOTE: Ensure that the legs are seated fully into the 3 way connectors using a rubber mallet.

6. Tighten all bolts.

3.5 Align Sensor Shrouds

1. Slide sensor shrouds to top of vertical 80/20 bar.
2. Tighten t-bolts to secure sensor shrouds.
3. Repeat the previous steps for each sensor.

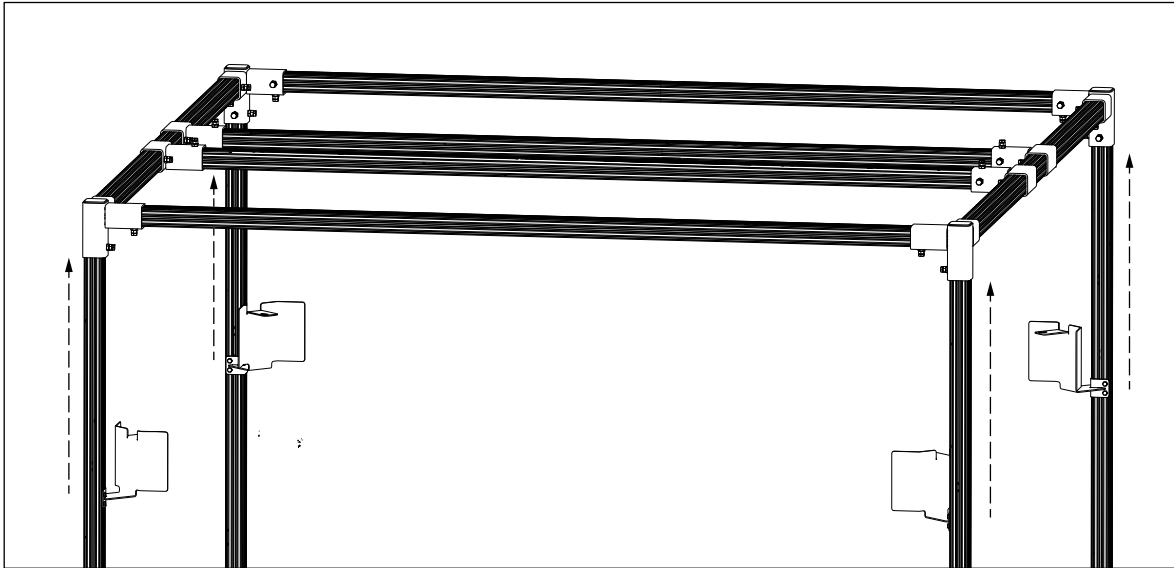

Figure 3-14. Remote IFM Sensor Assembly Attachment

3.6 Mount J-box

Attach the J-Box to the top of the enclosure.

1. Attach the top of the j-box (Pt.6) to top of 80/20 bars 2d and 2e with the four bolts (Pt.4) and four roll-in t-nuts (Pt.3).
2. Attach bottom of the j-box (Pt.14) to bottom of 80/20 bars 2d and 2e with four bolts (Pt.4) and four roll-in t-nuts (Pt.3).

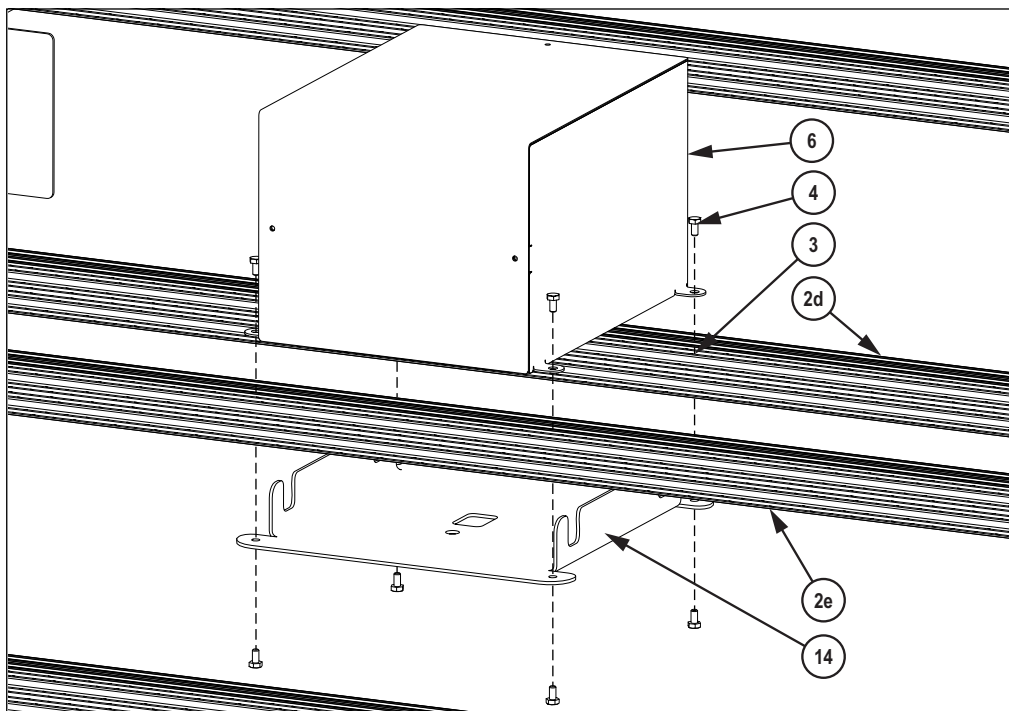



Figure 3-15. J-Box Installation

4.0 Suspended Flex Assembly

This section provides an overview of Suspended Flex assembly procedure.

 **NOTE:** Mount Suspended Flex assembly to an 80/20 mounting frame or a cable suspended mounting frame. See *iDimension 80/20 Mounting Frame Installation Addendum (PN 221406)* or *iDimension Cable Mounting Frame Installation Addendum (PN 221407)* for mounting frame installation instructions.

1. Extend the sensor array mount arms into 90 degree angles.

 **NOTE:** Position steel tongue at the end of each arm to face counter clockwise.

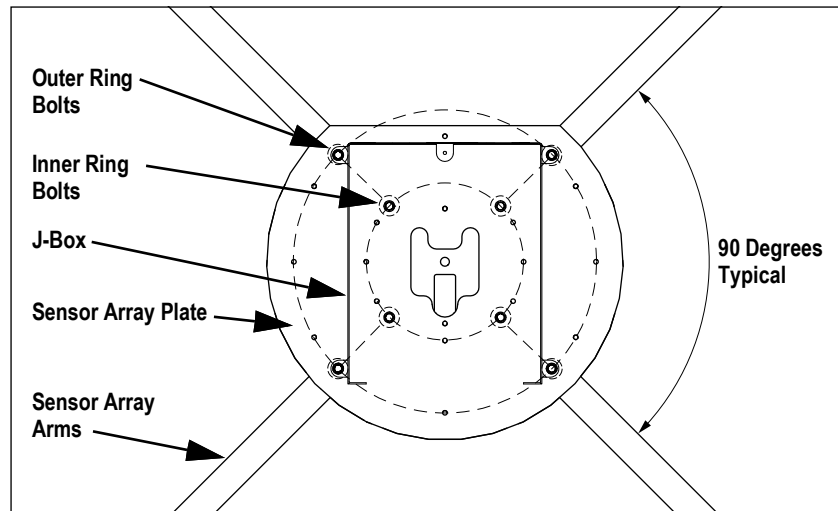

Figure 4-1. Sensor Array Assembly Attachment

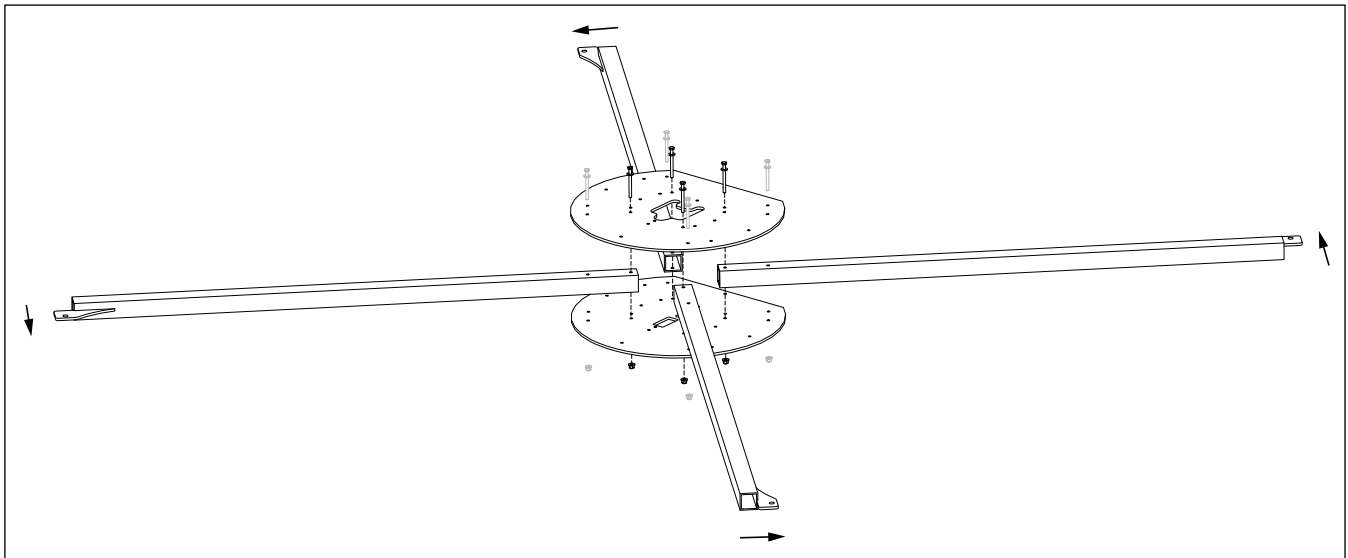

Figure 4-2. Sensor Array Mount Arm Orientation

2. Secure the inner ring of bolts into the sensor array mount arms and sensor array hub top and bottom plates.

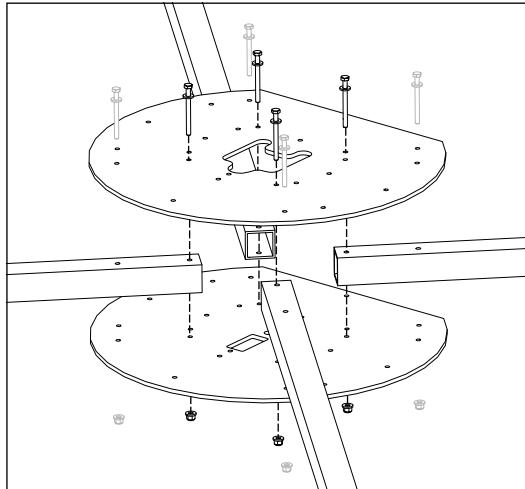

Figure 4-3. Sensor Array Assembly Attachment

3. Align j-box with the holes of the outer ring of the steel plate.
4. Secure outer ring of bolts through the j-box, the steel plates and the sensor array arms.

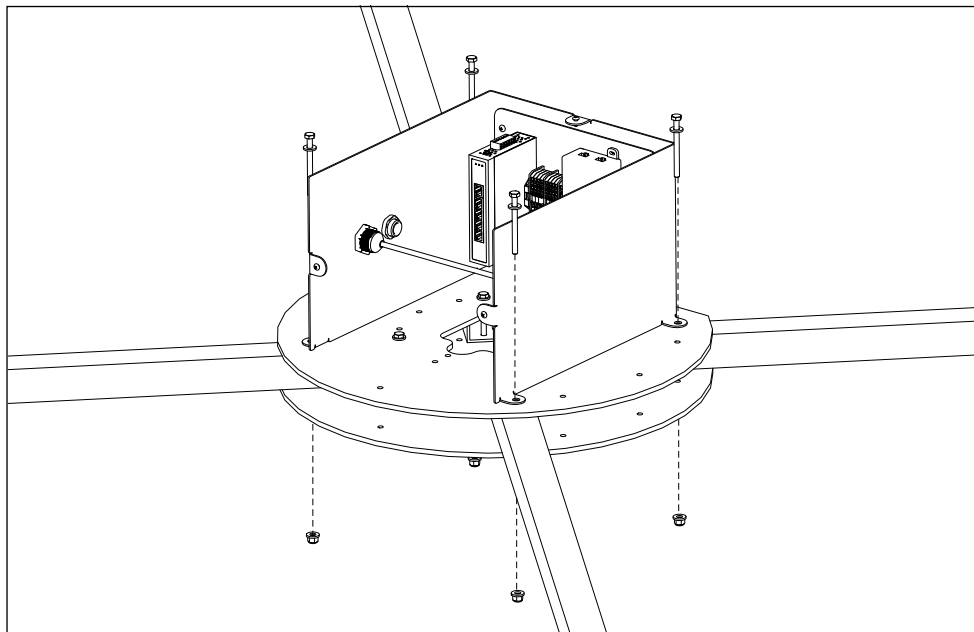

Figure 4-4. J-box Attachment

5. Lift the sensor array mount assembly to the mounting frame.
6. Secure the sensor array mount assembly to the mounting frame.

5.0 Accessories and Wiring

5.1 Sensors

Sensor assembly and installation into the sensor shield is similar on both the Free Standing and Suspended Flex assemblies.

Follow the steps below to assemble the sensors:

1. Secure the sensor mounting bracket to the sensor by following the remote IFM sensor instructions provided with the unit.
2. Place the two halves of the rod mount into the rod mount bracket.
3. Slide rod into the rod mount.
4. Tighten bolt to secure rod.

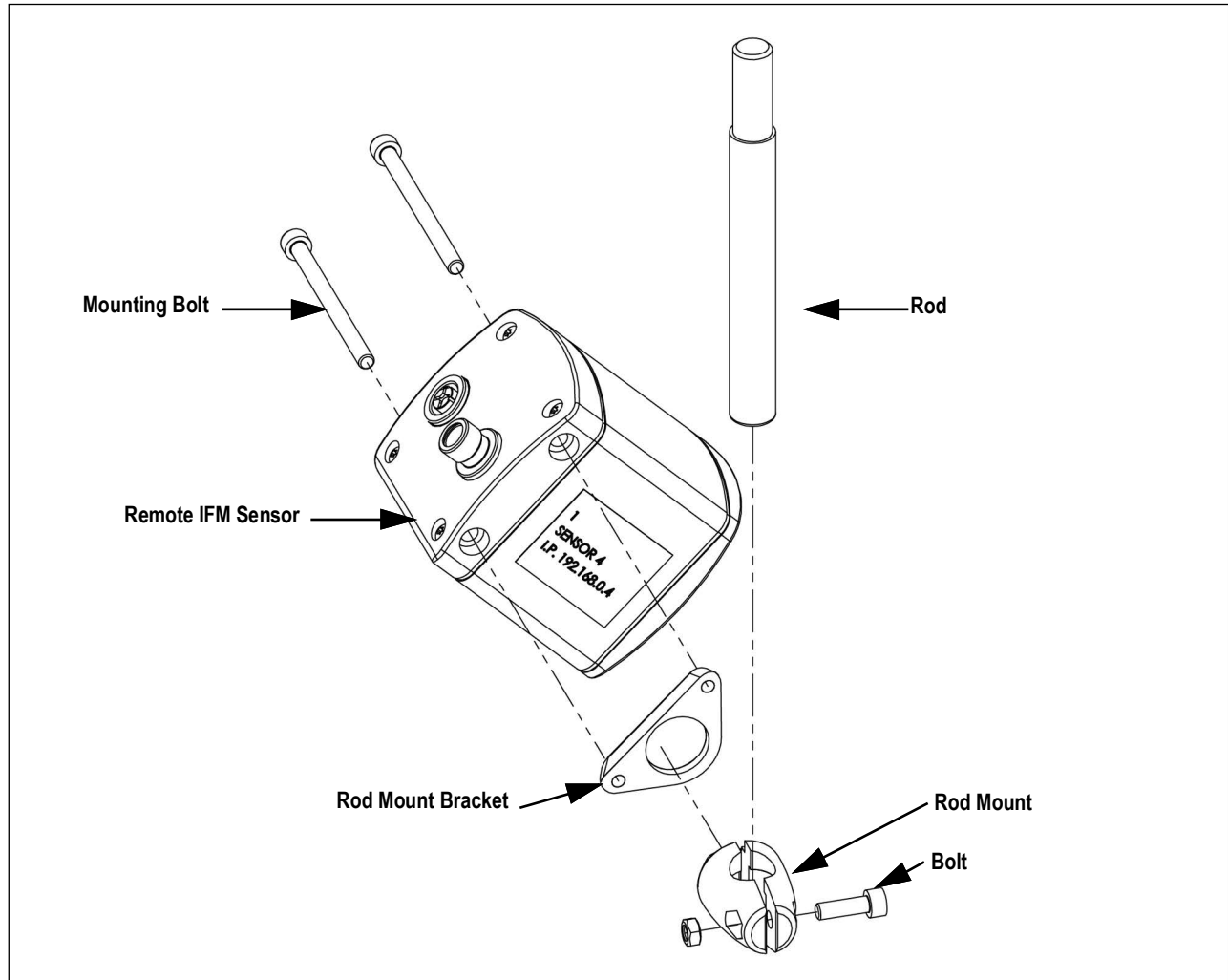



Figure 5-1. Remote IFM Sensor Assembly

- Secure rod of the remote IFM sensor assembly to shield mount through the slotted hole on the shield mount.

 **NOTE:** Orient the sensor downwards with the power connector pointing towards the sensor shield.

- Connect the power and ethernet cables to each sensor.

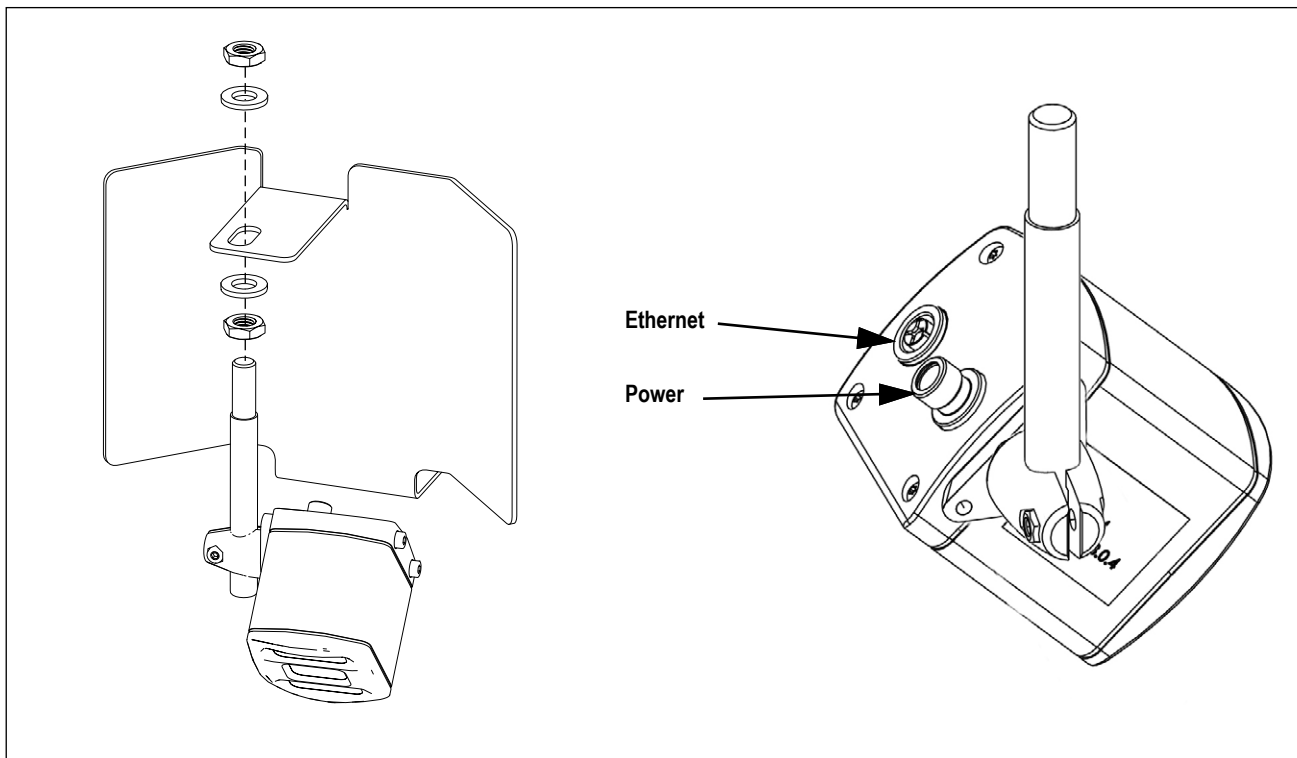

Figure 5-2. Remote IFM Sensor Wiring

- Connect remote IFM sensor ethernet cables (green) to the j-box ethernet ports (Figure 5-4 on page 26).
- Strip back 3/8 in of wire insulation at the j-box end of the IMF sensor power cables.
- Wire the remote IFM sensor power cables to the j-box terminal block (Figure 5-4 on page 26).
- Repeat for each sensor.

5.2 J-Box

The j-box is similar on both the free standing and Suspended flex assemblies.

Follow the steps below to access and wire the j-box:

1. Remove the three small screws on the exterior of the j-box.
2. Remove steel cover.
3. Wire j-box according to [Figure 5-4 on page 26](#).
4. Replace steel cover.
5. Replace the three small screws to secure cover of the j-box.

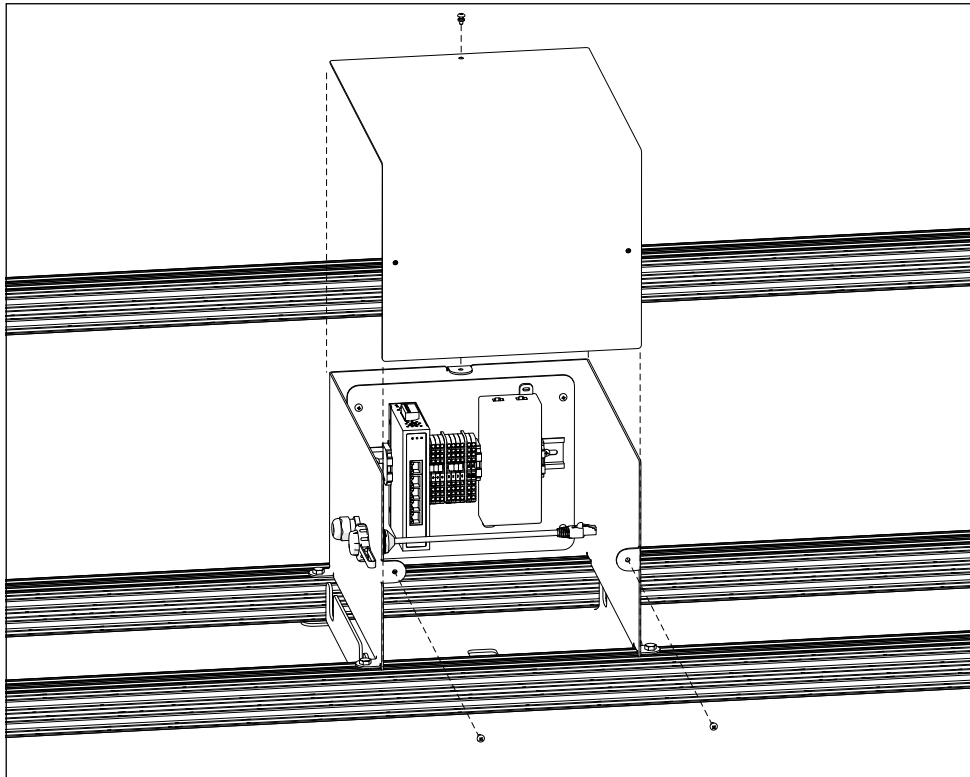

Figure 5-3. J-Box Cover Assembly

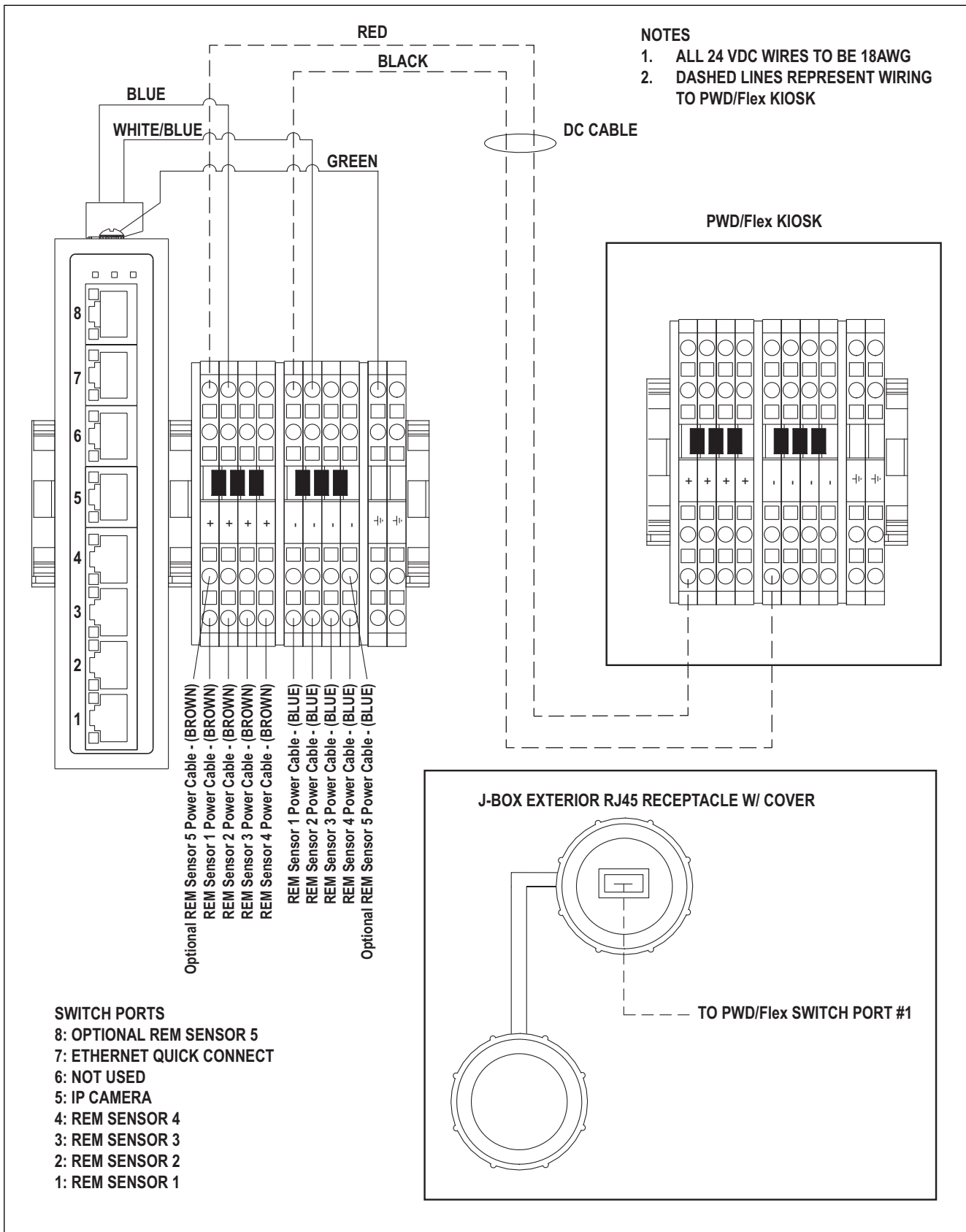

Figure 5-4. J-Box Wiring

5.3 Kiosk

5.3.1 Kiosk Wiring

1. Run ethernet and power cables from the j-box to the kiosk.



IMPORTANT: Ensure that all cables are secured to stationary objects between j-box and kiosk so that they do not pose as a catching or tripping hazard.



NOTE: If installing kiosk onto optional kiosk stand, run cables through the hole in the kiosk and stand. Do not install kiosk icotek block. See [Section 5.3.2 on page 29](#) for installation onto optional kiosk stand.

2. Remove the entire icotek[®] cable gland block.
3. Feed all ethernet and power cables through cable gland grommets.



NOTE: Punch a hole into each required cable grommet to allow wiring to be fed through the block.

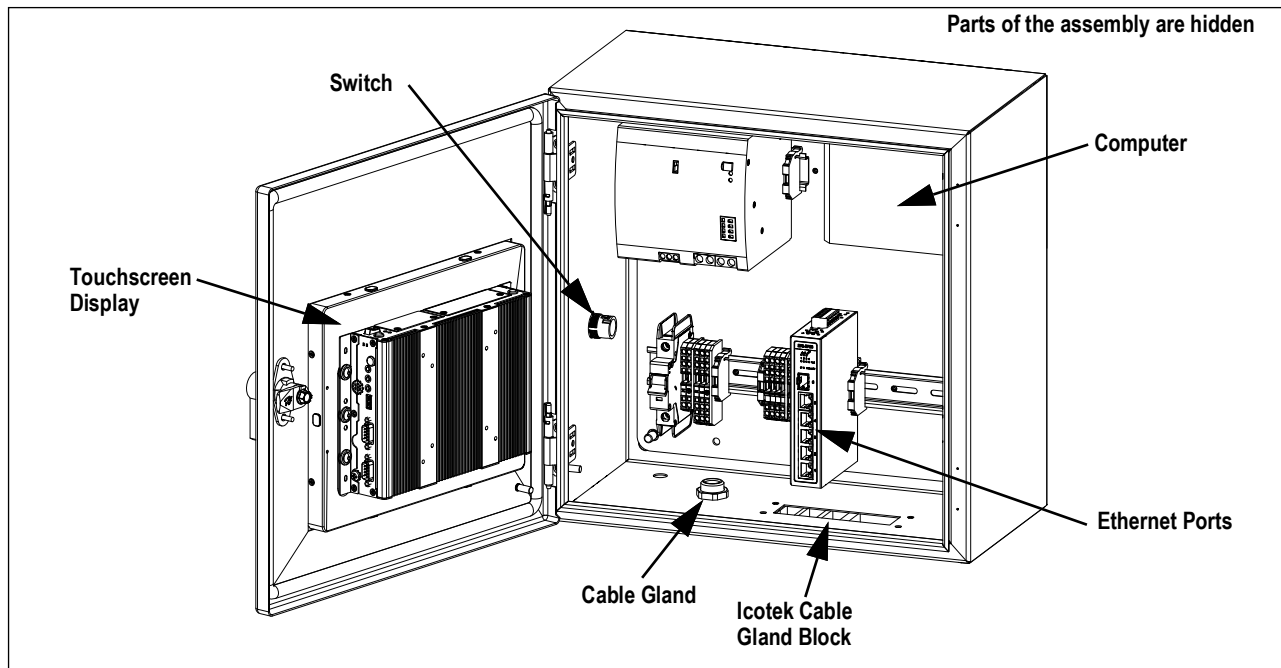

Figure 5-5. Kiosk Assembly

4. Reinstall icotek cable gland block.



IMPORTANT: When reinstalling the icotek cable gland block, leave the cable gland block slightly loose to allow for cable slack to prevent potential cable damage.

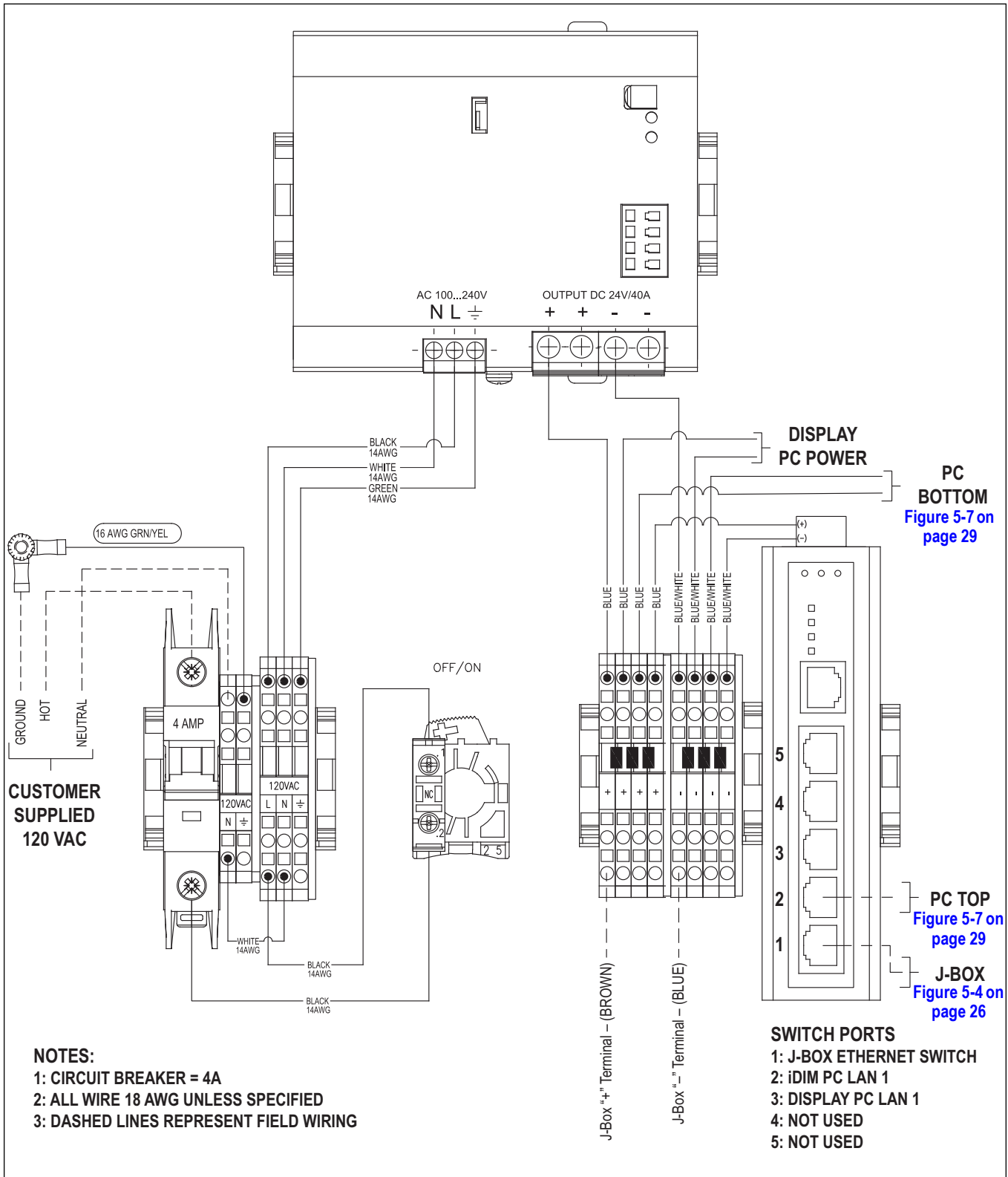

Figure 5-6. Kiosk Wiring

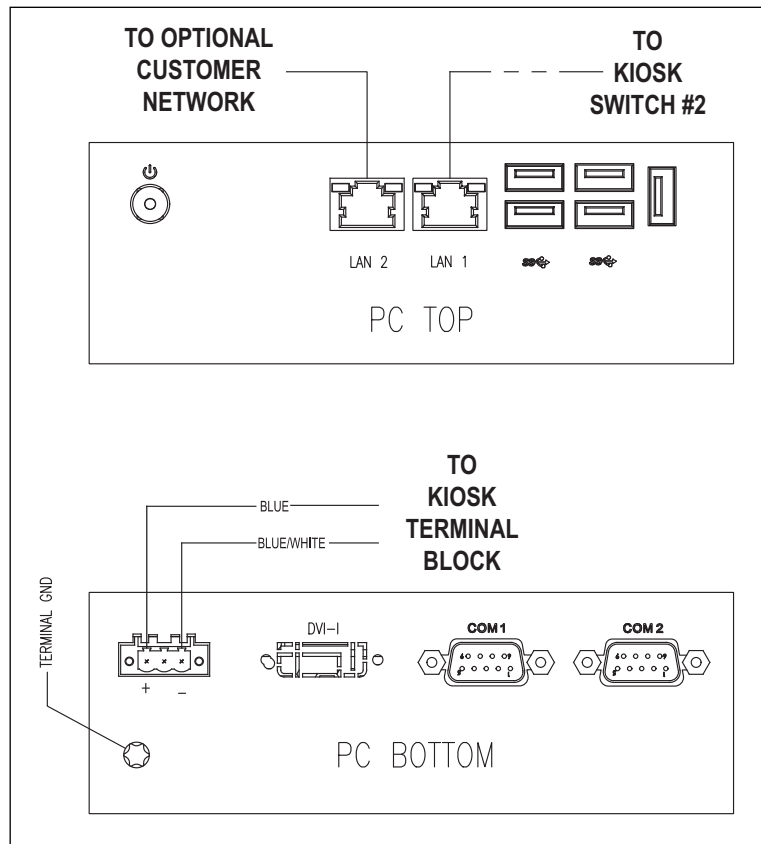

Figure 5-7. Kiosk PC Wiring

5.3.2 Optional Kiosk Stand

1. Align bottom of kiosk to openings in top of kiosk stand.
2. Bolt Kiosk to top of stand.
3. Run all wires through the icotek cable gland at the base of the stand and into the bottom of the kiosk as in [Section 5.3 on page 27](#).

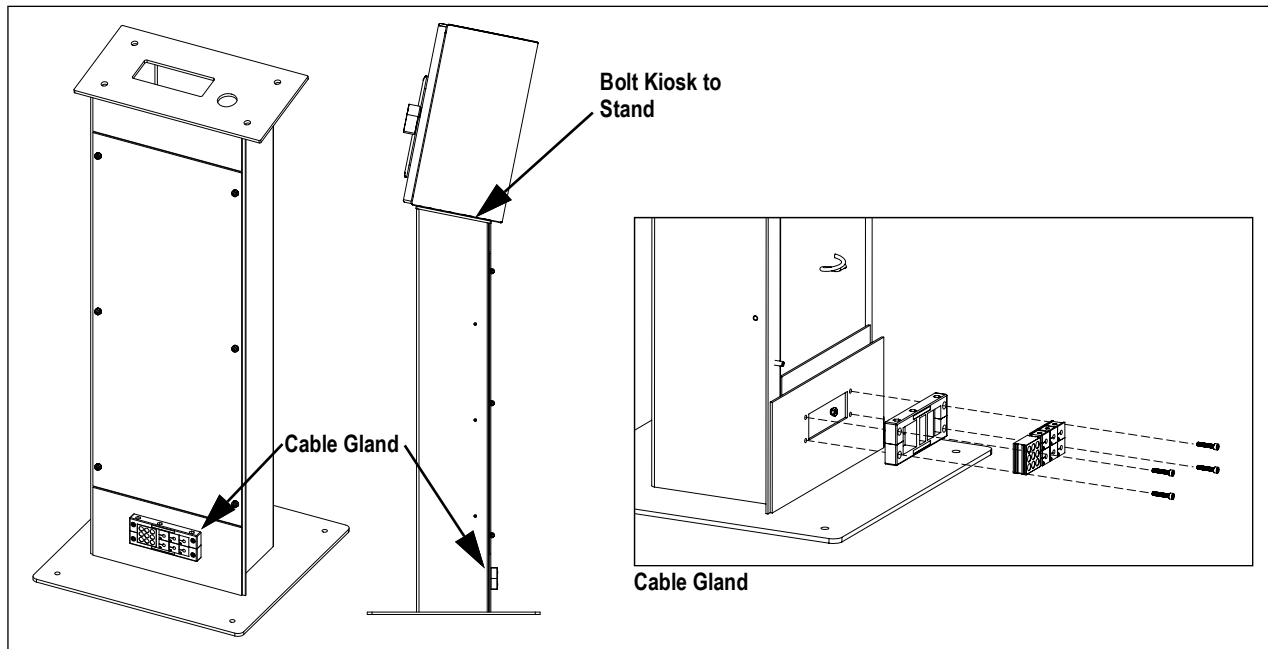

Figure 5-8. Optional Kiosk Stand

5.3.3 Optional Kiosk Mount

1. Position the first U-bolt on the pillar.
2. Place the U-bolt threads through the top mount plate holes.
3. Bolt the mounting plate in place.



CAUTION: Torque each bolt to 25 ft-lb to prevent injury and damage from falling kiosk.

4. Repeat [Step 1](#) through [Step 3](#) with the second U-bolt through the bottom mount plate holes.



NOTE: If adding the optional kiosk shelf (PN 212260), mount it between the kiosk and the mounting plate (see [Figure 5-9](#)).

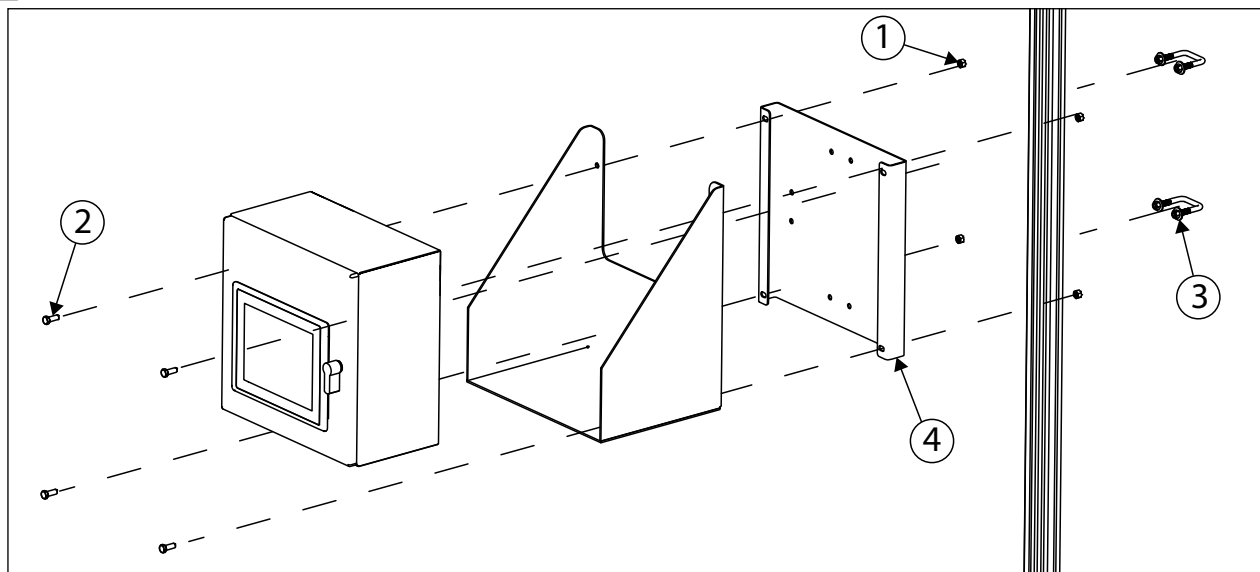

Figure 5-9. Optional Kiosk Mount

Item No.	Part Number	Description	Qty.
1	132684	Nut, 3/8-16NC HEX Steel Zinc Plated	4
2	170550	Bolt, 3/8-16NC HEX Steel Zinc Plated	4
3	214413	U-Bolt, Square	2
4	220135	80/20 Idim Kiosk Mount Plate	1

Table 5-1. Optional Kiosk Mount Part Kit (PN 220137)

5.4 IP Camera (PN 200168)

1. Install the IP camera to a sensor array mount assembly arm or freestanding frame. Use hardware provided in the Optional IP Camera Kit.



NOTE: It is recommended to install the IP camera at the center of the sensor array mount assembly arm. Do not install near any remote IFM sensor to avoid causing interference.

2. Wire the IP camera through the sensor array mount assembly arm

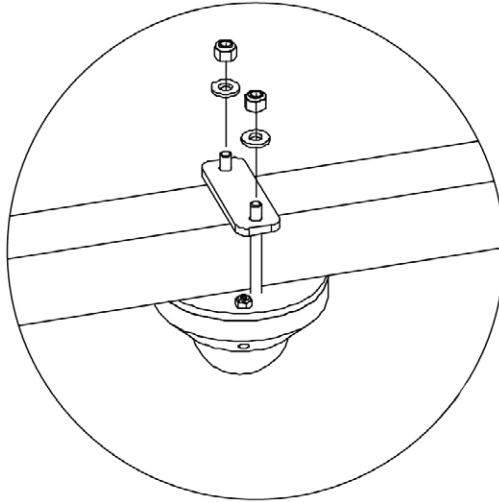

Figure 5-10. Optional IP Camera



© Rice Lake Weighing Systems Content subject to change without notice.

230 W. Coleman St. • Rice Lake, WI 54868 • USA USA: 800-472-6703 • International: +1-715-234-9171