

CLS-M3

Cargo Lift Scale

Installation & Service Manual



RICE LAKE[®]
WEIGHING SYSTEMS

157393 Rev F

- 1.0 Introduction..... 1**
 - 1.1 Safety..... 1
 - 1.2 Considerations Before Installation..... 2
 - 1.2.1 Forklift Derating..... 2
 - 1.2.2 Forklift Battery and CLS Installation..... 3
 - 1.3 CLS-M3 Power and PC Connection..... 3
 - 1.4 iQube2® J-Box Introduction..... 3
- 2.0 Scale Base Installation..... 4**
 - 2.1 Before Installation..... 4
 - 2.2 Tools Needed to Install the CLS-M onto the Forklift..... 4
 - 2.3 Unpacking..... 5
 - 2.3.1 Unpacking a One Scale Configuration..... 5
 - 2.3.2 Unpacking a Two Scale Configuration..... 7
 - 2.4 Scale Base Installation..... 9
 - 2.5 Connect the Coiled Interface Cable to J-Box..... 11
 - 2.6 Install Forks onto Scale Assembly..... 11
- 3.0 Cable Connections..... 12**
 - 3.1 Routing Coiled Interface Cable..... 12
 - 3.2 Pre-installed RS-232 Adapter Cable..... 13
 - 3.3 Connecting the Coiled Interface Cable/RS-232 Adapter Cable to Mobile PC..... 13
 - 3.4 Check Scale for Accuracy..... 13
- 4.0 Revolution® Interface to CLS-M..... 14**
 - 4.1 Connect Scale to Revolution..... 14
 - 4.2 Live Weight Data..... 16
 - 4.3 Leveling Forklift Forks..... 17
 - 4.4 Calibration..... 19
 - 4.4.1 Reading Data In Live Weight Screen..... 22
 - 4.5 EZ Setup/Upload Unit Serial Number..... 23
 - 4.6 Diagnostics..... 24
- 5.0 Calibration..... 27**
 - 5.1 Carriage J-Box Calibration Mode..... 27
 - 5.2 Leveling Forklift Forks..... 27
 - 5.3 Calibrate Scale Using Revolution..... 28
 - 5.3.1 Reading Data In Live Weight Screen..... 31
 - 5.4 Weights and Measures Sealing..... 32
- 6.0 Load Cell Replacement and Flexure Troubleshooting..... 33**
 - 6.1 Required Tools for Replacing a Load Cell..... 33
 - 6.2 Load Cell Replacement..... 34
 - 6.3 Forklift Flexure Troubleshooting - 28" and 34" Models..... 41



Technical training seminars are available through Rice Lake Weighing Systems. Course descriptions and dates can be viewed at www.ricelake.com/training or obtained by calling 715-234-9171 and asking for the training department.

| | | |
|------------|---|-----------|
| 7.0 | iQube2® J-Box | 42 |
| | 7.1 iQube2 J-Box Replacement | 42 |
| | 7.2 Download the Serial Number to the J-Box | 44 |
| | 7.3 iQube2 PCB Board Assembly Replacement | 45 |
| | 7.4 iQube 2.3 Cross References | 46 |
| 8.0 | Appendix | 47 |
| | 8.1 Parts Breakout | 47 |
| | 8.2 Troubleshooting Table | 51 |
| | 8.3 Troubleshooting iQube2 LEDs | 53 |



Rice Lake continually offers web-based video training on a growing selection of product-related topics at no cost. Visit www.ricelake.com/webinars

1.0 Introduction

The *Cargo Lift Scale* is a rugged, dependable cargo lift scale that can withstand many years of repeated use. When mounted on a forklift, the *CLS-M3* saves time and money by allowing you to weigh loads immediately instead of carrying the load to a floor scale.

This manual is for trained and qualified personnel responsible for installing and servicing the *Cargo Lift Scale (CLS-M3)*. This manual covers information on the installation and service of the scale carriage, coiled interface cable to the mobile PC.

1.1 Safety

Safety Symbol Definitions:



DANGER Indicates an imminently hazardous situation that, if not avoided, will result in death or serious injury.



WARNING Indicates a potentially hazardous situation that, if not avoided could result in death or serious injury, and includes hazards that are exposed when guards are removed.



CAUTION Indicates a potentially hazardous situation that, if not avoided may result in minor or moderate injury.



Important Indicates information about procedures that, if not observed, could result in damage to equipment or corruption to and loss of data.

General Safety



Do not operate or work on this equipment unless you have read and understand the instructions and warnings in the *Installation, Operation and Maintenance Manual*. Failure to follow the instructions or heed the warnings could result in injury or death. Contact any Rice Lake Weighing System dealer for replacement manuals. Proper care is your responsibility.



Failure to heed may result in serious injury of death.

Some procedures described in this manual require work inside the j-box. These procedures are to be performed by qualified service personnel only.

Take all necessary safety precautions when installing the scale carriage including wearing safety shoes, protective eye wear, and using the proper tools.

Do not allow minors (children) or inexperienced persons to operate this unit.

Do not operate without all shields and guards in place.

Do not jump on the scale.

Do not use for purposes other than weight taking.

Do not place fingers into slots or possible pinch points.

Do not use any load bearing component that is worn beyond 5% of the original dimension.

Do not use this product if any of the components are cracked.

Do not exceed the rated load limit of the unit.

Do not make alterations or modifications to the unit.

Do not remove or obscure warning labels.

Do not use near water.

Keep hands, feet and loose clothing away from moving parts.

1.2 Considerations Before Installation

1.2.1 Forklift Derating

Capacity Reduction Calculation

While the *CLS-M3* will fit most typical forklifts, there are considerations that must be taken into account prior to installation. Due to the extra weight of the *CLS-M3*, the net lifting capacity of the forklift is reduced by approximately 10 percent. Use the formula below to calculate the amount to down-rate the lifting capacity and determine the net capacity of the forklift.

$$\text{Net Capacity} = \frac{A (B + C) - D (E + F)}{E + G + H}$$

| | |
|--|---|
| A = Truck Basic Capacity in pounds | B = Inches from front wheel center line to fork face |
| C = Inches from face to truck rating point (usually 24) | D = Weight of scale in pounds |
| E = Inches from front wheel center line to carriage face | F = Inches from carriage face to scale horizontal center of gravity (HCG) |
| G = J + K (inches from carriage face to rear face of load) | H = Inches from fork face to new truck rating point |
| J = Thickness of fork | K = Thickness of scale |

CLS Classes and ID Plates

During the initial sale or installation of the *CLS-M3*, remind the customer that they must have an updated ID plate on the forklift stating the new lifting capacity and center of gravity information. This is required per OSHA rules and regulations.

| | 28 inch | 34 inch | 38 inch |
|---|---------|---------|---------|
| Vertical center of gravity (VCG) of scale = | 8.06 | 8.06 | 10.15 |
| Horizontal center of gravity (HCG) of scale = | 2.09 | 2.09 | 2.83 |
| Effective thickness (ET) of scale = | 4.55 | 4.55 | 6.06 |
| Weight of scale = | 392 | 420 | 987 |

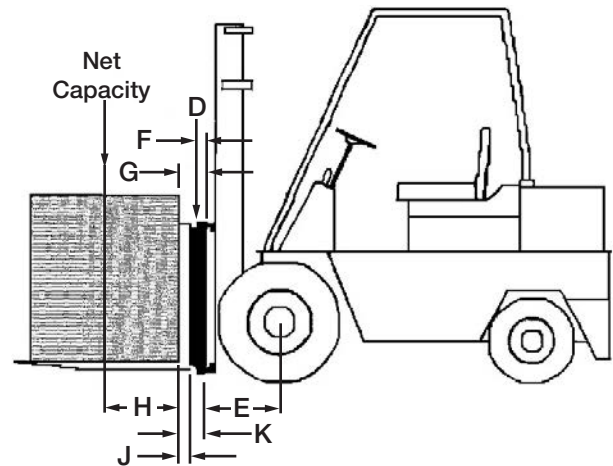
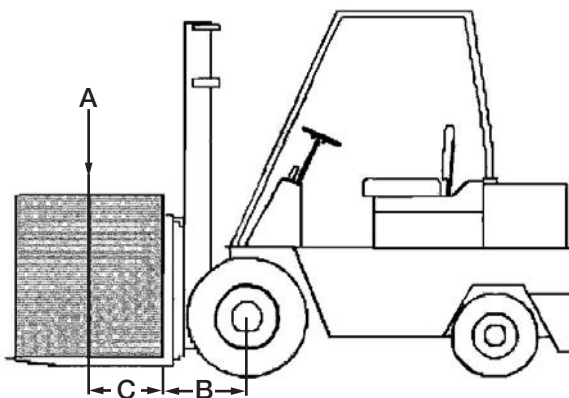

1.2.2 Forklift Battery and CLS Installation



Take into consideration that the indicator power source will be connected directly to the battery of the forklift. Most typical is 12 volts for propane, gas and diesel forklifts.

12 volt systems must have a negative ground so ensure the forklift has a negative ground electrical system. The CLS will not operate on a positive ground forklift. Refer to the forklift users manual to further verify grounding requirements.

The standard CLS scales use 9-36V power supply for use on 12 V batteries. If the forklift is an electric system, make sure to install:

PN 166162 – DC-DC Converter, CLS

PN 166161 – Power Line Filter, CLS (for static protection)

1.3 CLS-M3 Power and PC Connection

The *CLS-M3* receives power from a mobile PC through the RS-232 port, this eliminates the need for a Communication/Power box.

The iQube2 j-box interfaces to Virtui² software that has been pre-installed on the mobile PCs operating system. It allows the operator to display weight and zero the scale.

To calibrate and troubleshoot the *CLS-M3*, Revolution– software has been installed on the mobile PC as well.

The mobile PC receives data and power (5V on pin 9) from the iQube2 j-box through the *Coiled Interface Cable*, PN 156295 and RS-232 adapter cable (PN 156296).



Figure 1-1. Coiled Interface Cable and Adapter

1.4 iQube2® J-Box Introduction

The iQube2 j-box sits in an area between the front and back plate of the scale itself providing protection for the j-box. It comes from the factory pre-wired and no additional work needs to be done to it other than sealing it for Legal for Trade applications.

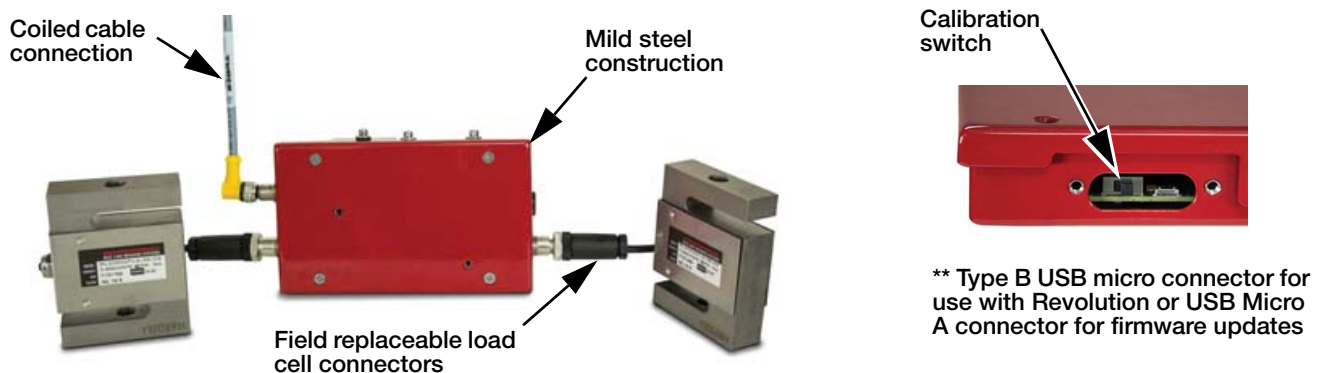

Figure 1-2. Two-Channel J-Box on CLS-M Scale



Note After successful installation (Section 2.0) and calibration (Section 5.0), replace the cover on the scale assembly and secure with bolt and washer.

2.0 Scale Base Installation

This section describes procedures for installing the *Cargo Lift Scale* base.



WARNING Take all necessary safety precautions when installing the scale carriage, including wearing safety shoes and protective eyewear, and using the proper tools, which are listed in Section 2.4.

The *Cargo Lift Scale* is shipped from the factory with the scale already calibrated and all settings stored in the j-box. Minimal adjustments and calibration might be necessary once the scale is installed onto the forklift. Those calibration steps are contained in Section 4.6 on page 36.

2.1 Before Installation

Before installing the *CLS* on a forklift, the forklift should be in good operating condition for optimal weighing accuracy. Look for the following items prior to installing the *CLS* onto a forklift:

- Inspect the forks for any damage.
- Check the locking pin on the forks for proper function.
- Check and adjust the lift chain so the heel of the forks have 1/2 to 1 inch of clearance from the floor when the carriage is down and the mast is vertical.
- The slot for the center pin should be clear of grease and debris.
- The top cleats of the forklift rest on the top of the scale and should remain clear of grease and debris that could alter the scale's performance.

The power/communication box will be connected directly to the battery of the forklift. The *CLS* scale works with 9-36 VDC power source.



CAUTION All systems must have a negative ground.

2.2 Tools Needed to Install the CLS-M onto the Forklift

Once the forklift is deemed in good mechanical and operating condition, use the following tools to remove it from its shipping pallet and install onto the forklift.

| Tool | Size | Purpose of Tool |
|--------------------------------|-----------------|--|
| Allen wrench | 4 mm | For service only, to remove j-box |
| Crescent wrench | 2 in adjustable | For adjusting the shim bolts and jam nuts. |
| Tin snips or band cutters | NA | To cut the plastic banding surrounding the CLS while on the pallet. |
| Torque wrench w/ 1/2" Allen | 1/2 in | To tighten the cleats to 125 ft-lb. |
| Electric grinder | | For grinding the center pin if necessary and the mounting bolts. |
| Wrench | 7/16 in | To connect power/communication box to mounting plates. |
| Wrench & socket | 9/16 in | To connect mounting plates to forklift carriage. |
| USB Type "A" to Type "B" Cable | 6 ft min | Use with laptop for access to Revolution software for diagnostics, calibration and displayed weight. |
| Level | NA | To perform angle zero calibration. |
| Fish tape | 6 ft min | Route power cable to forklift battery. |
| Crimping tool | NA | Battery connections. |

Table 2-1. Recommended Tools for Unpacking and Installation of the CLS-M

2.3 Unpacking

The CLS is shipped upright on a sealed pallet with one or two scales per pallet, as shown in Figure 2-1.

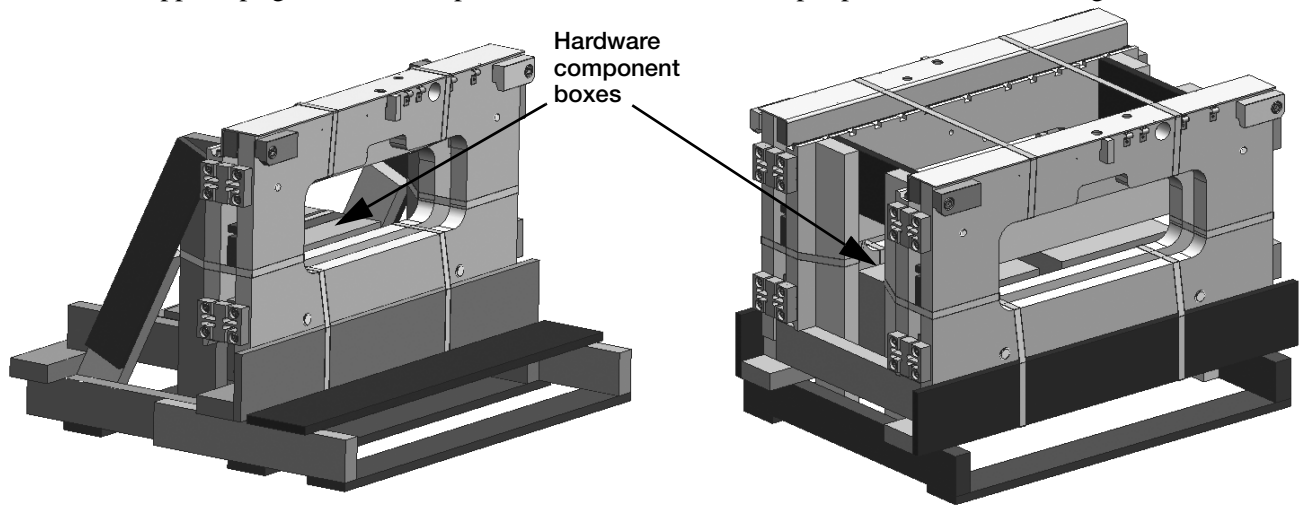

Figure 2-1. CLS-M Packaging

Upon receipt of the shipping pallet, inspect it for any visible signs of damage. Immediately after unpacking, visually inspect the contents to ensure all components are included and undamaged. The shipping pallet should contain the following:

- One or two scale carriage assemblies with cover plate
- Hardware component boxes, which include:
 - Two cleats with four bolts
 - One coiled interface cable
 - One power cable and hardware for battery connection
 - One power/communication box
 - One mounting kit for power/communication box with hardware



Note To ensure that all products received from the manufacturer are in good shape upon arrival, it is recommended to fully inspect all contents and properly fill out the bill of lading.

If any parts were damaged in shipment, notify the shipper immediately.

2.3.1 Unpacking a One Scale Configuration

The scale is shipped in an upright position as illustrated in Figure 2-2. The upright position allows for ease of installation. The power/communication box and accessories are located in a hardware component box.

1. Clip plastic band holding hardware component box in place and remove box.
2. Remove protective wood piece from the front of the scale.
3. Remove the front pallet support.
4. Clip the remaining plastic bands that are encircling the scale.
5. Remove the protective wood piece which protects the front of the scale.

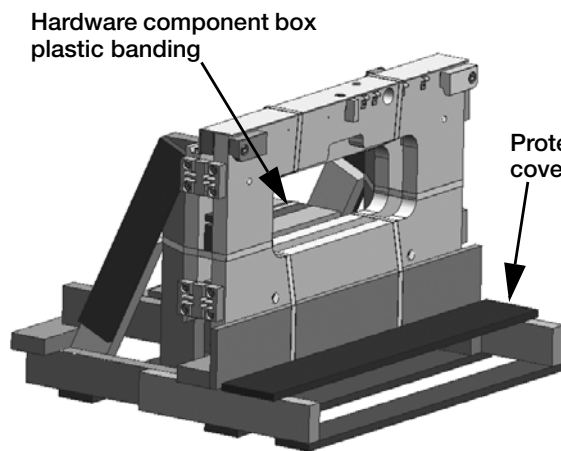
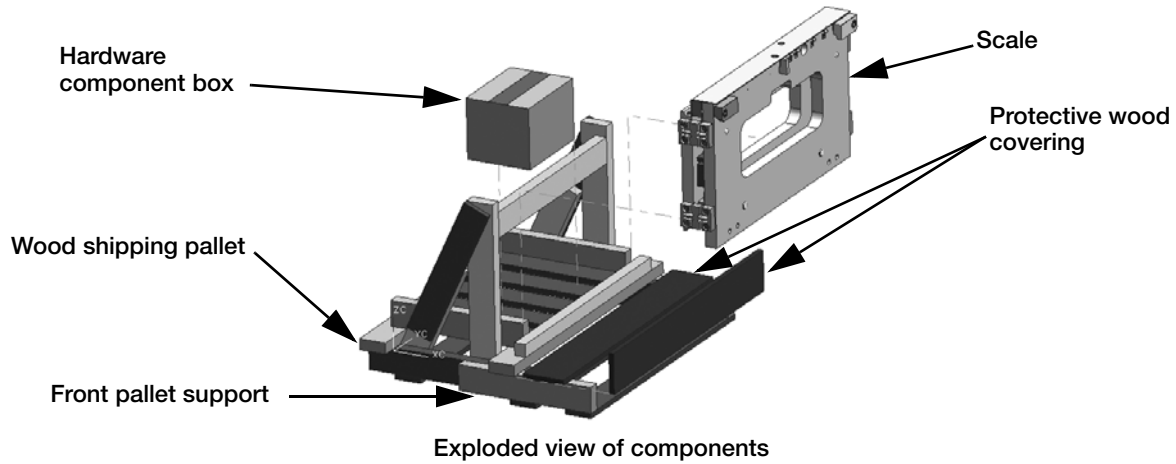

Step 1: Clip plastic band securing hardware component box

Step 2: Remove protective wood covering

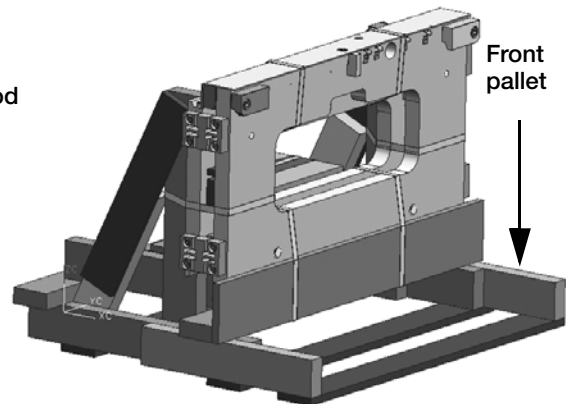

Step 3: Remove front pallet support

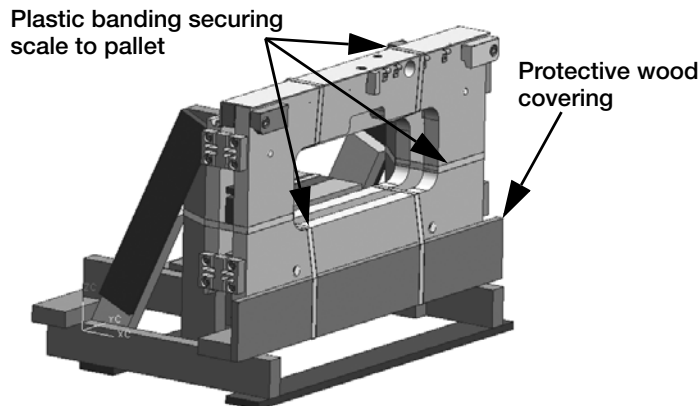

Step 4: Clip remaining plastic bands

Step 5: Remove protective wood

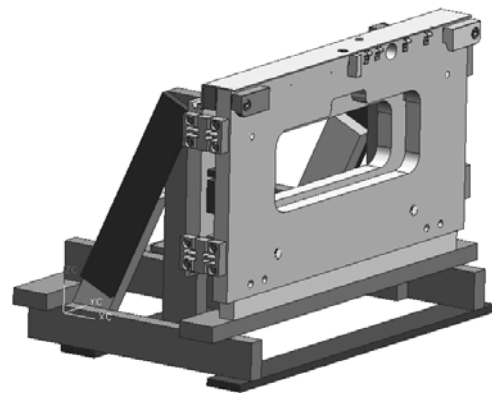

Scale is now ready for installation

Figure 2-2. Scale Component Parts on Shipping Pallet for One Scale

2.3.2 Unpacking a Two Scale Configuration

The scales are shipped in an upright position as illustrated in Figure 2-3. The upright position allows for ease of installation. The power/communication box and accessories are located in a hardware component box.



WARNING *When installing from a two scale configuration, complete all of steps for scale one before clipping plastic bands securing second scale to the shipping pallet.*

1. Clip top plastic bands.
2. Clip plastic band securing cardboard boxes to shipping pallet.
3. Remove the cardboard boxes.
4. Clip plastic bands from scale one.
5. Remove protective wood covering for scale one.

Scale one is ready for installation.

6. Once scale one has been installed, clip plastic bands from scale two.
7. Remove protective wood covering for scale two.

Scale two is now ready for installation.

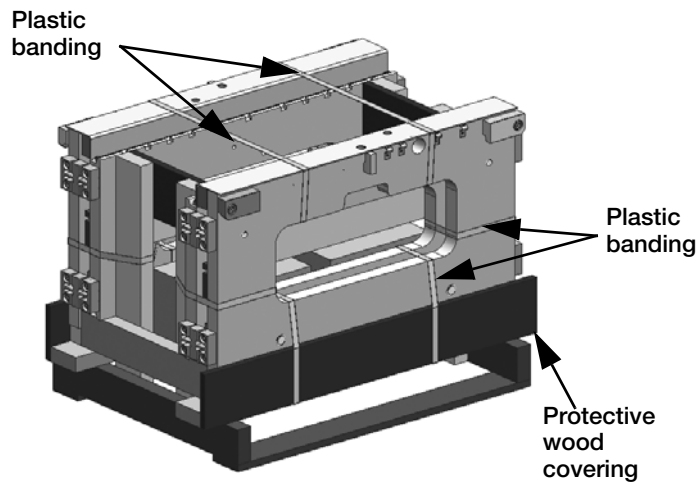
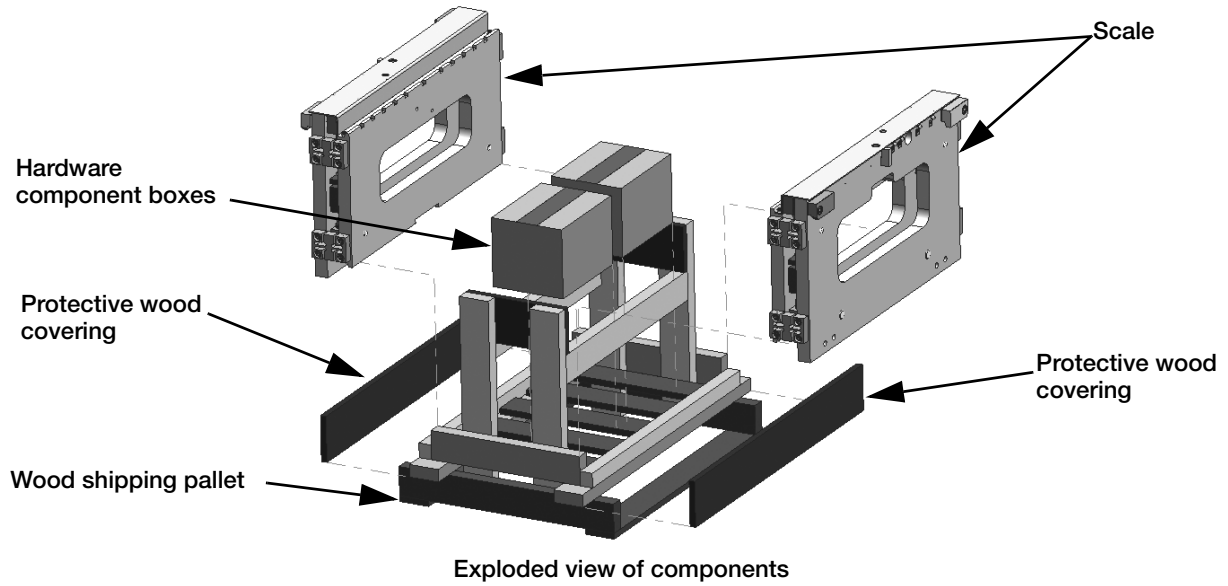

- Step 1: Clip top plastic bands
- Step 2: Clip plastic band to release hardware component boxes
- Step 3: Remove hardware component boxes
- Step 4: Clip plastic bands from first scale
- Step 5: Remove protective wood covering for first

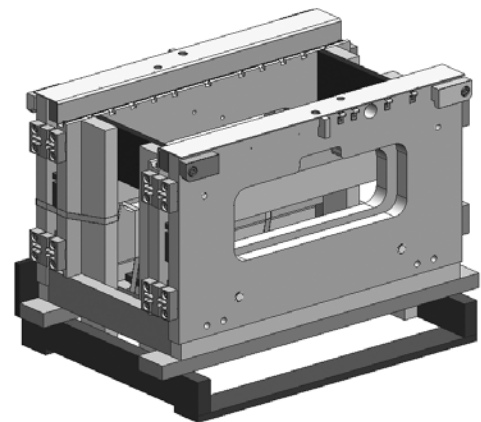

Scale one is ready for installation.
DO NOT clip the plastic band from scale two until scale one is installed

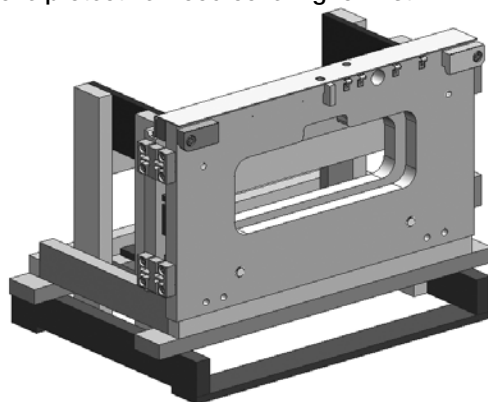

- Step 6: Clip plastic bands from scale two.
 - Step 7: Remove protective wood covering for second scale.
- Scale two is ready for installation.

Figure 2-3. Scale Component Parts on Shipping Pallet for Two Scales

2.4 Scale Base Installation

Use the following steps to install the scale base to the forklift.

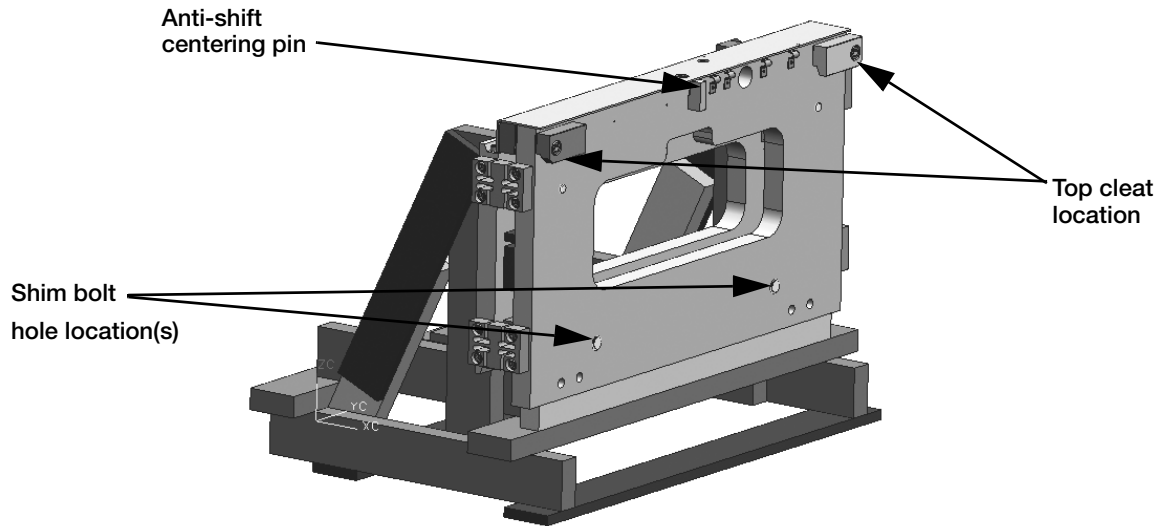

Figure 2-4. Anti-shift Centering Pin, Shim Bolts and Top Cleat Locations (One Scale Configuration Shown)



CAUTION Verify that the shim bolts are flush with the back plate of the scale. Not doing so will place the entire scale out of alignment when attaching it onto the forklift and will make it difficult to make final adjustments once the scale is mounted onto the forklift.

1. Making sure the forks are removed from the forklift, move the forklift in close to the pallet and scale.
2. Ensure the anti-shift centering pin on the scale assembly is aligned with the center notch on the forklift carriage.



Note The scale's centering pin should be aligned with the middle notch of the forklift carriage. Verify that the centering pin is adjusted so that the pin is located well within the center notch area of the carriage. The centering pin should not touch the bottom of the notch on the original carriage, as this will cause side to side tilting of the scale. The outside top cleats provide support to the scale assembly and the centering pin only helps to position the scale on the forklift carriage. The centering pin should not bear any weight. If it does, the use of a grinder to grind down the centering pin will help remedy that.

3. Tilt the mast forward slightly to catch the scale assembly.
4. Carefully and slowly raise the scale carriage slightly so the top cleats (cleat location shown in Figure 2-4) of the scale hook onto the forklift carriage. If they do not hook, push the scale toward the forklift as it is being raised.
5. Tilt the mast back to secure the connection and raise the scale to shoulder height.
6. Attach the bottom cleats to the bottom of the scale assembly (see Figure 2-5 for bottom cleat location), so that the lip of the cleat is behind the scale carriage.
7. Torque the bottom cleat retaining bolts to 125 ft-lb.



WARNING Failure to properly torque the bottom plate retaining bolts may result in bodily harm or damage to equipment.

8. Adjust the shim bolts so there is a minimal clearance between the bottom cleats and the scale carriage of 0.020-inch thickness. This can be measured by using the included feeler gauge.



Note Failure to adjust shim bolts to proper clearance of 0.020 inches may result in binding, poor accuracy or improper fit of attachment to forklift.

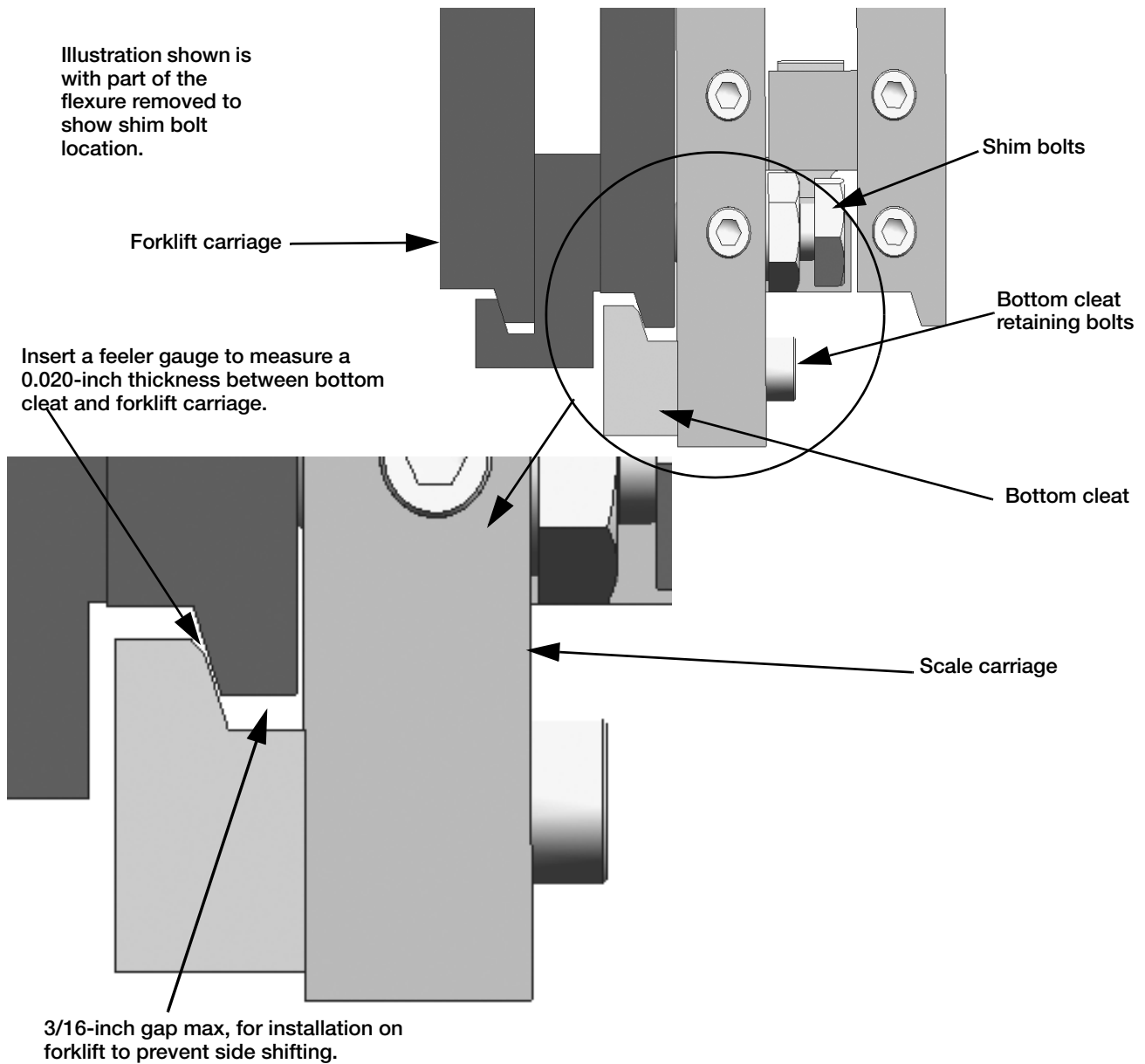

Figure 2-5. Bottom Cleat Location and Assembly

9. Upon successful installation and calibration verification, seal the carriage j-box and load cell quick disconnects for Weights and Measurements approval.

2.5 Connect the Coiled Interface Cable to J-Box

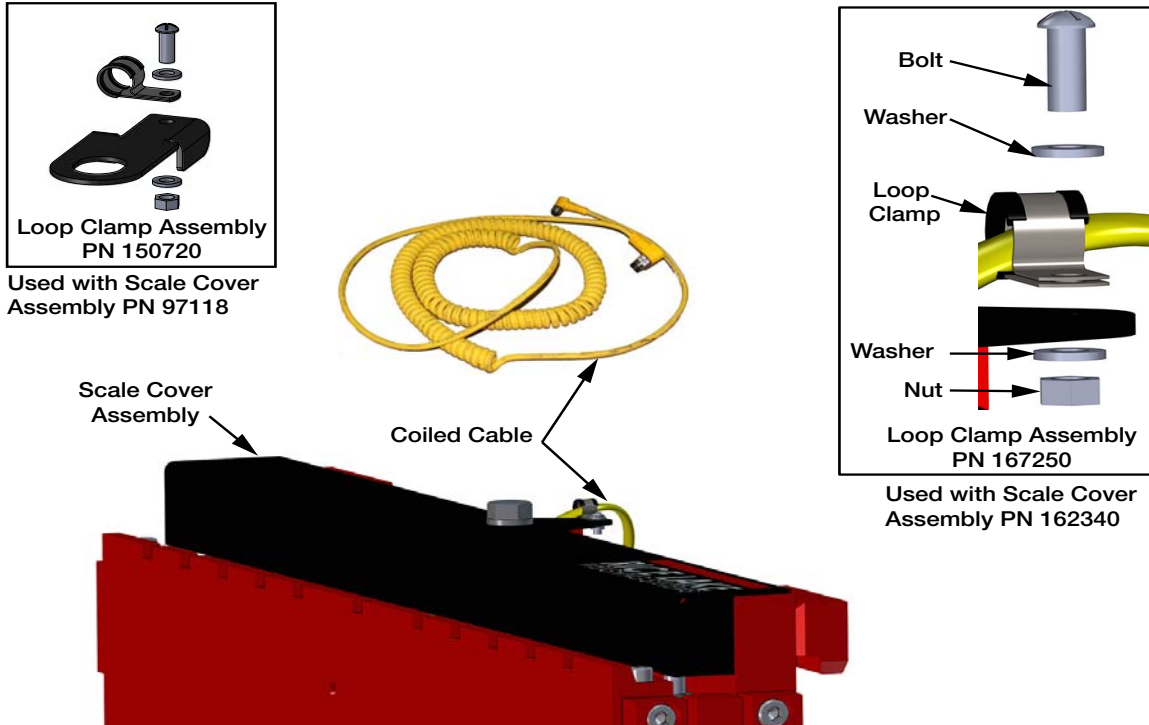

Figure 2-6. Connecting the Coiled Cable

1. Loosen the bolt holding the cover to the scale assembly and remove cover. See Figure 2-6.
2. Assemble loop clamp kit to the coiled interface cable.
3. Route the coiled cable through clips on backside of carriage toward middle. For proper coiled cable routing, tighten clips. Set the other end of the cable aside until the power/communication box is installed (See Section 3 on page 14).
4. Push the coiled interface cable through the hole in the scale and connect it to the j-box. See Figure 2-6.
5. Position the scale cover assembly and the loop clamp assembly to the scale and secure with the bolt and washer.



Note After successful installation (Section 2.0 and Section 3.0) and calibration (Section 5.0), replace the cover on the scale assembly and secure with bolt and washer.

2.6 Install Forks onto Scale Assembly

The forks need to be installed onto the scale assembly.

1. Align a fork to the center of the scale assembly making sure it is over the top of the assembly.
2. Lift the carriage slightly to set the fork, and then slide the fork to the side of the scale. Let it stop in the 2nd notch from the end and latch it in place.
3. Repeat process for other fork, sliding it the opposite direction on the scale.

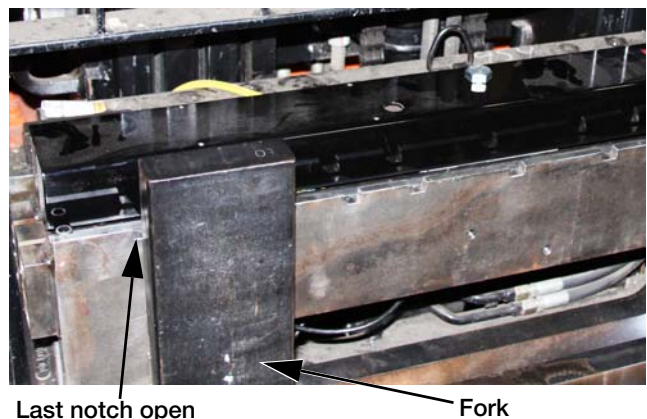

Figure 2-7. Fork Attachment



Note For accurate weighing, it is best to leave forks at the second notch from the outside edge of the scale.

3.0 Cable Connections



Figure 3-1. Coiled Interface Cable

3.1 Routing Coiled Interface Cable

Special care should be taken when routing the coiled interface cable. To ensure that the cable is installed properly and away from situations that could cause it harm use the following steps:

1. The cable was connected to the load cell j-box during the scale installation. Retrieve the cable and route to the mobile PC from the forklift scale.
2. Routing of cable will vary depending on forklift style. The preferred route for a single stage forklift is through the center of the mast, up the front/right upright, to the area where the mobile PC is mounted.

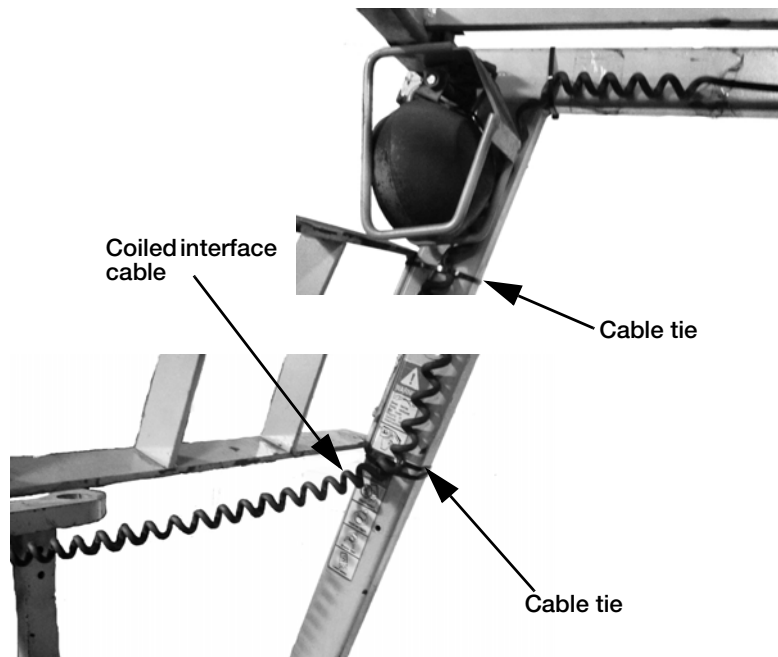

Figure 3-2. Signal Cable Located Between the Scale and the Mobile PC

3. Secure with cable ties at the scale, at the top of the mast and several other locations to keep it securely in place.
4. Slowly and carefully extend the mast to all positions to confirm that the cable isn't pulled too tight or that there are no pinch points along the way.
5. Check for proper signal cable clearance as the side shifter (if used), is moved back and forth.



Note When routing cables do not obstruct the view of OSHA labels on the forklift.

3.2 Pre-installed RS-232 Adapter Cable

The RS-232 adapter cable (coiled cable to 9-pin RS-232) may be pre-installed from the factory onto the mobile PC.

1. Ensure the mobile PC is OFF
2. Connect the coiled cable to RS-232 adapter cable, secure with tie wraps to reduce accidental damage.



3.3 Connecting the Coiled Interface Cable/RS-232 Adapter Cable to Mobile PC

1. Ensure the mobile PC is off.
2. Connect female M16 connector to coiled cable.
3. Connect DB-9 connector to PC.
4. Attach cable to forklift cage with the wraps to reduce accidental damage.

3.4 Check Scale for Accuracy

For this application, the customer has pre-installed the Revolution software on the mobile PC. Follow the instructions provided by the customer for accessing Revolution.

4.0 Revolution® Interface to CLS-M

Revolution is a tool to display weight, diagnostics and calibration (if required) of the *CLS-M3* scale using a Windows® based computer.

4.1 Connect Scale to Revolution

1. Open the Revolution program on the computer.

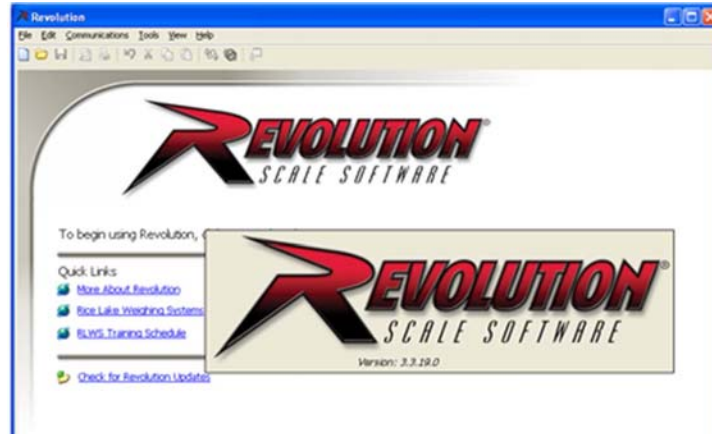

Figure 4-1. Revolution Screen at Open

2. Select *File/New* from the main toolbar.
3. Select the *CLS-M Forklift* option listed below for your model.
4. Press OK.

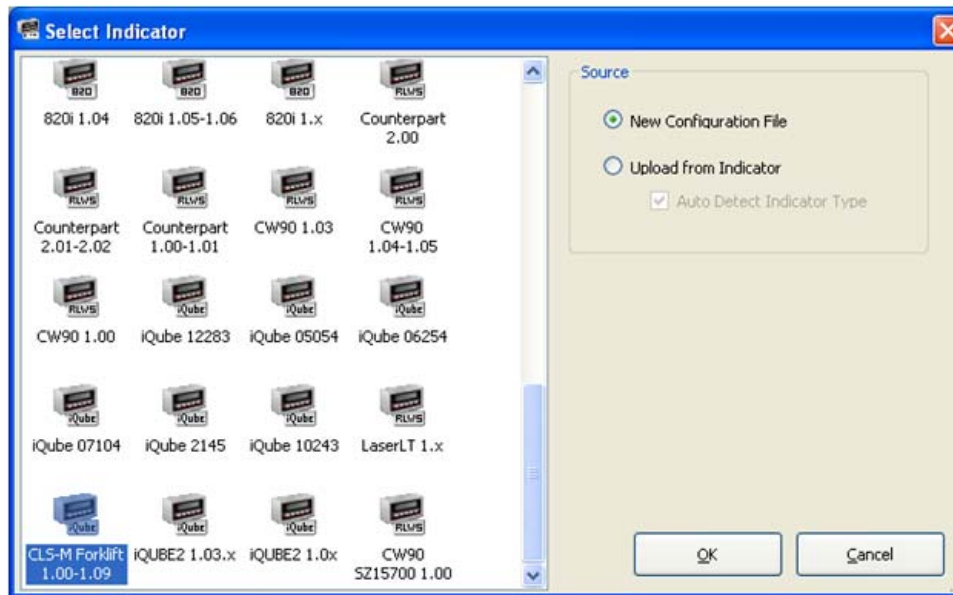

Figure 4-2. Open Revolution to CLS-M3 Module

- Once selected, the main screen shown in Figure 4-3 is displayed.

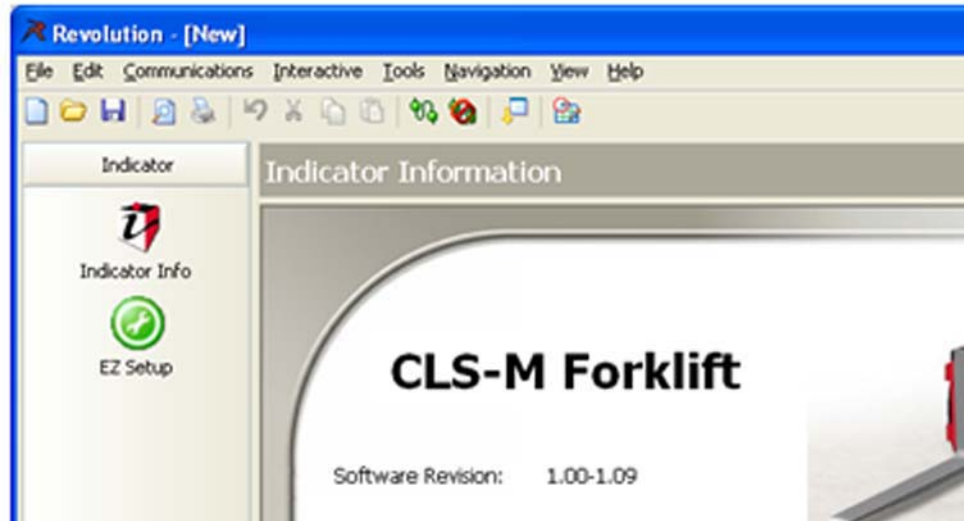

Figure 4-3. Expanded Pitch Angle Selection

- Go to Tools/Options (Figure 4-4 A) and select **Settings** (B), then choose the **PC Comm Port** (C).
- Select available RS-232 Comm port.
- Click OK (Figure 4-4 D).

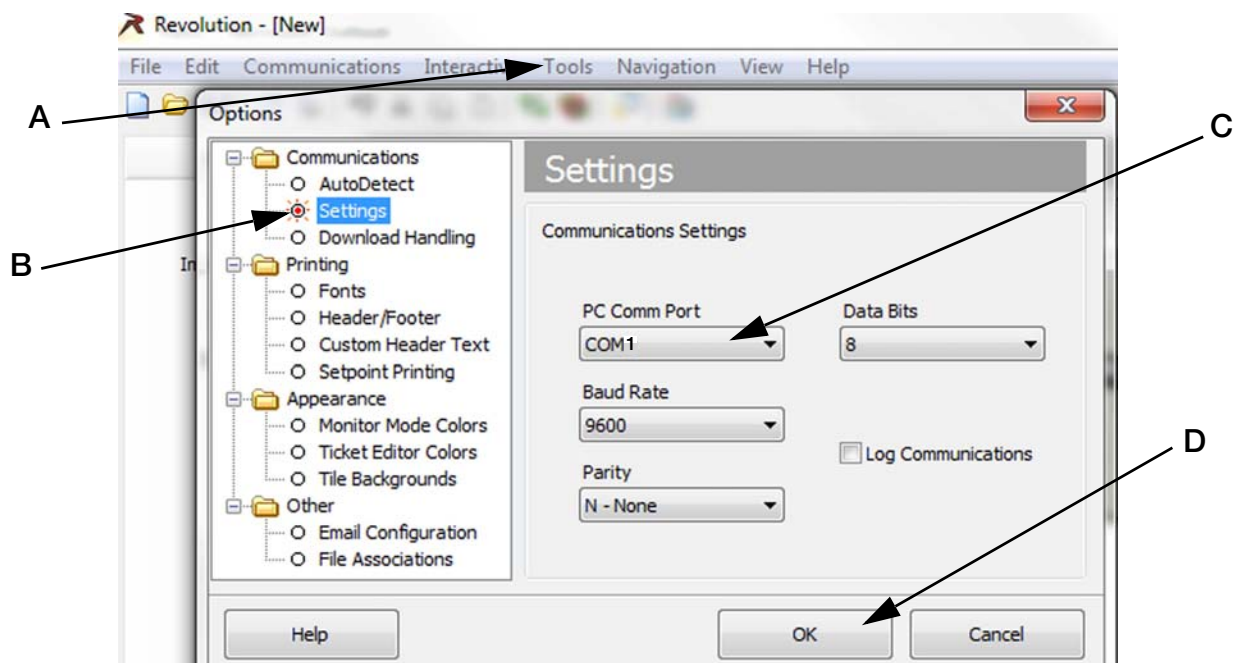

Figure 4-4. Options Screen to Select Comm Port for USB

- Select the connect icon from toolbar (Figure 4-5 A). A pop-up box comes up momentarily (Figure 4-6 A) to indicate the computer is now indicated to the box.
- If it comes up as **Unable to Connect to Indicator** (Figure 4-6 on page 16 B) verify the Comm Port is correct and that the mobile PC is turned on. Then select **GO** (Figure 4-6 on page 16 C) to connect.

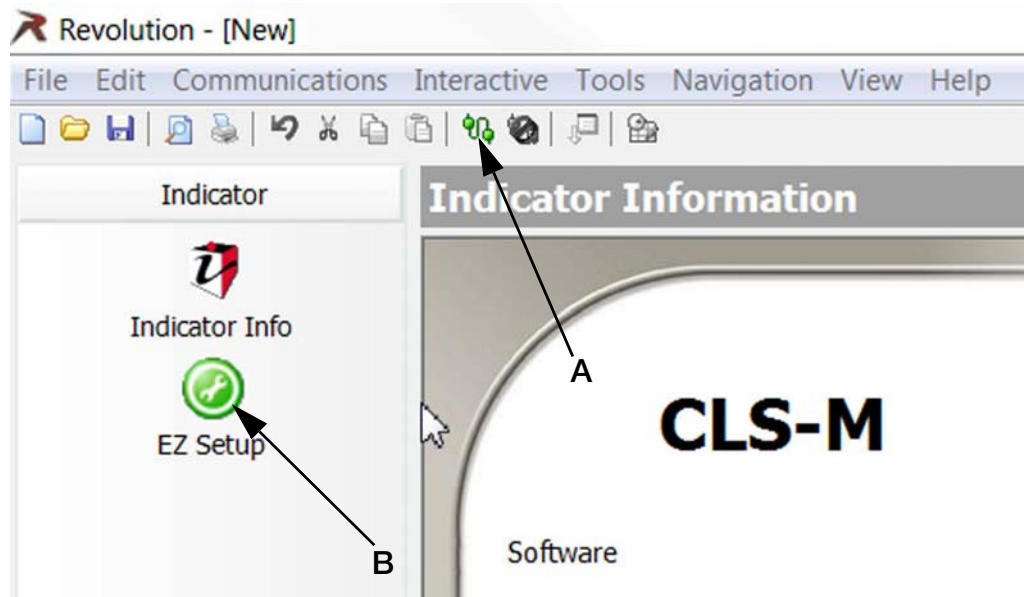

Figure 4-5. Connect Revolution

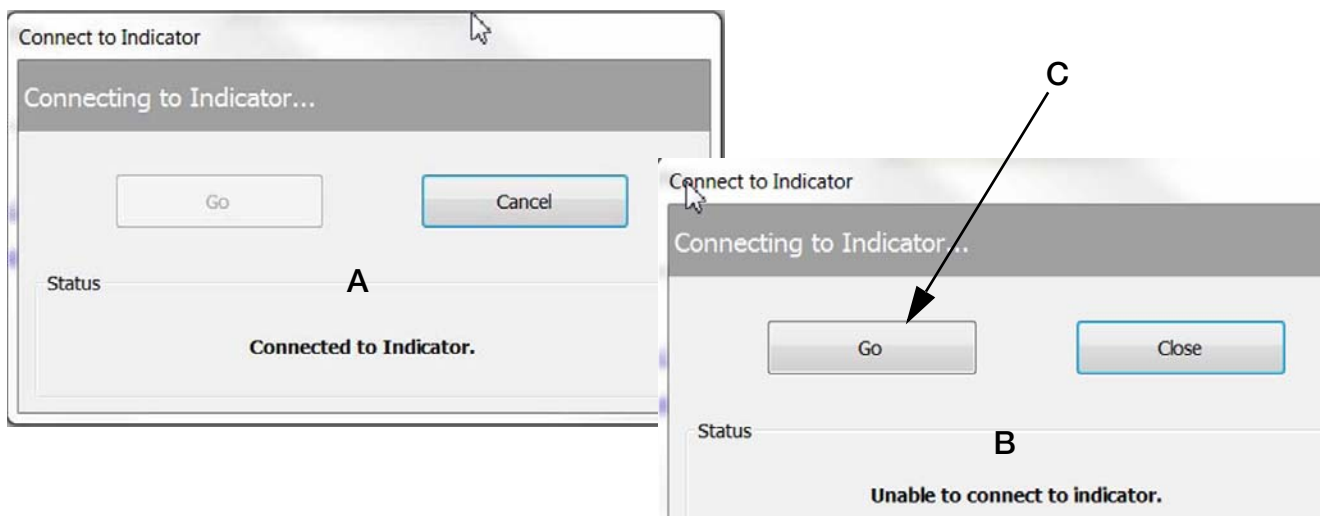

Figure 4-6. Connection Success/Failure

11. Press EZ Setup button (B).

4.2 Live Weight Data

The second tab is the *Live Weight Data* screen. This screen is used during calibration of the scale to verify the weight values. The *Live Weight Data* screen will only operate with the calibration switch in the closed position.

1. Select the *Live Weight Data* tab (Figure 4-7).



Note *Weight data packet screen shows output format of CLS-M3. Other displays include weight, pitch angle, roll angle, cell 1 & 2mV. (Figure 4-7). This is the information that will be sent to the customer supplied hand-held device when attached through Bluetooth.*

To start streaming data check the auto refresh box. If not checked the refresh button will need to be selected after each change of weight to load cell.

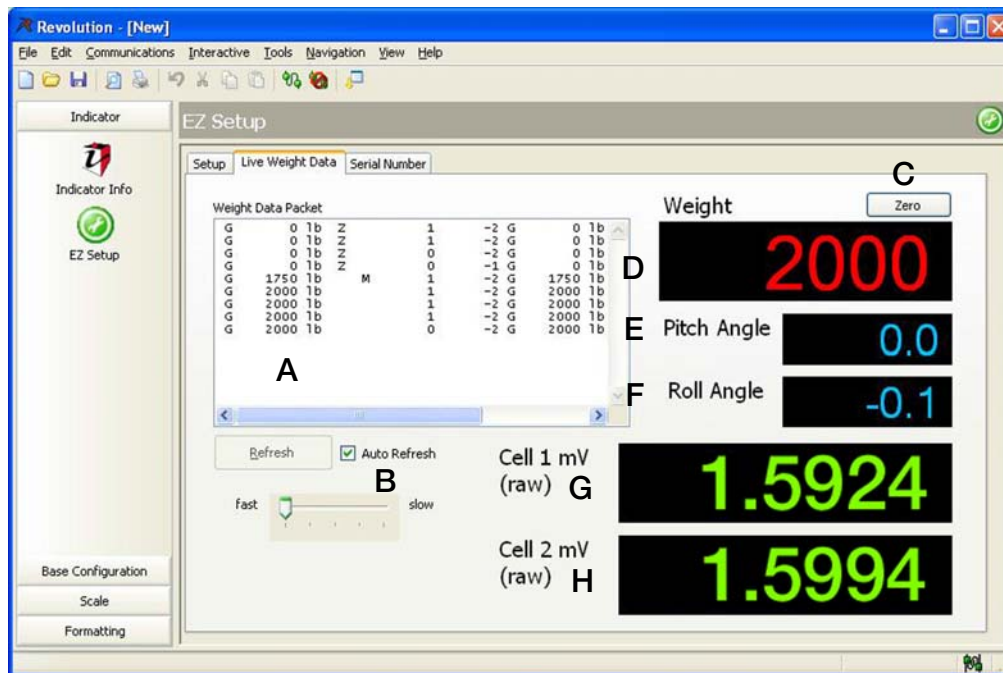

Figure 4-7. Revolution Live Weight Data screen.

- A. Weight Data Packet - output format/displays the output protocol of the CLS-M3.
- B. Auto Refresh - when checked it starts continuous streaming of data in the weight data packet.
- C. Zero - used to zero the scale.
- D. Weight - displays value of weight on scale.
- E. Pitch Angle - angle of the scale in a front to back direction.
- F. Roll Angle - angle of the scale in a side to side direction.
- G. Cell 1 mV (raw)
- H. Cell 2 mV (raw)

4.3 Leveling Forklift Forks

1. Level the forks to 0° by placing a level on the forks and adjusting as required.



Note Carriage j-box will need to be in setup mode (See Section 5.3)

Turn off the forklift after leveling forks, high vibration from the running engine will cause inaccurate readings.

2. In the setup screen, press Zero Angle (Figure 4-8 A).
3. A pop-up appears as shown in (Figure 4-8 B), press OK to close the pop-up box.

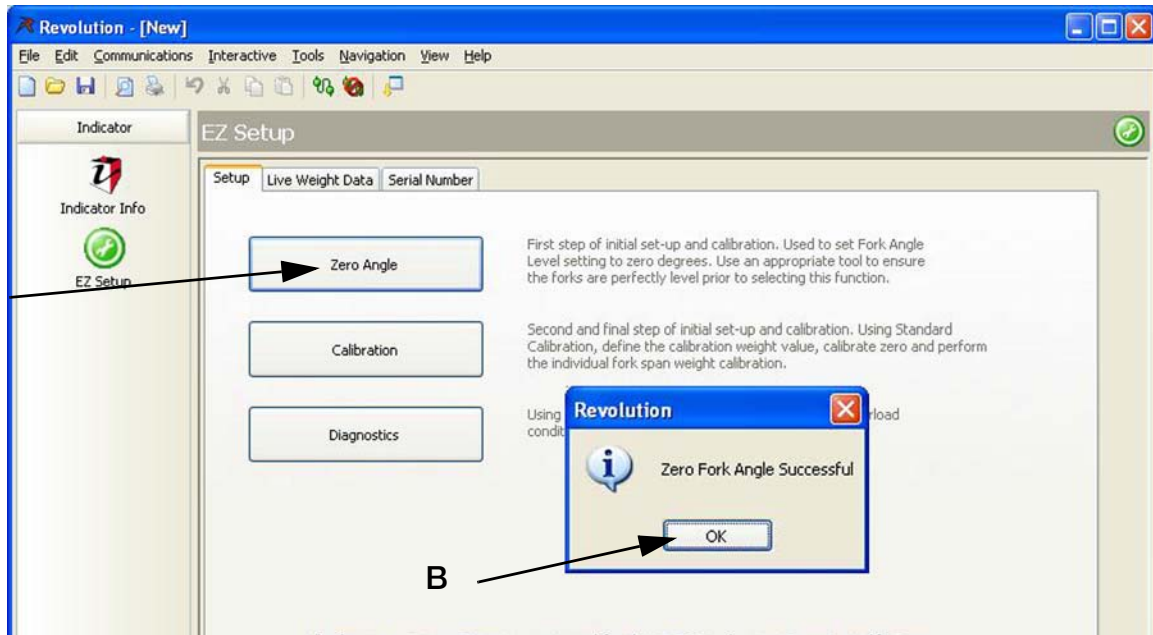



Figure 4-8. Zero Forks



Note Forks should be level when testing calibration. A degree of tilt in either direction can cause errors in the use of the scale.

4.4 Calibration

 **Note** The carriage j-box will need to be in setup mode (See Section 5.3)

1. Select *Standard Calibration* (Figure 4-9 B)
2. Press *Next* (Figure 4-9 C).

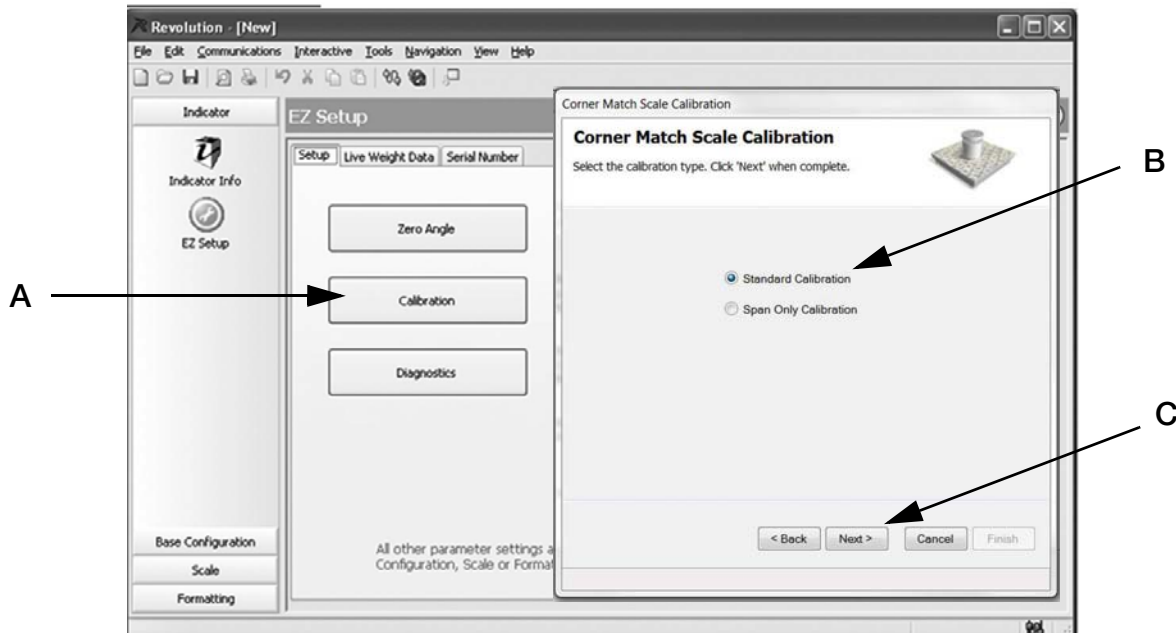

Figure 4-9. Enter Calibration

3. Enter test weight value to be used and press *Next* (Figure 4-10 A).
Certified Test Weight used during cell normalization must be checked.

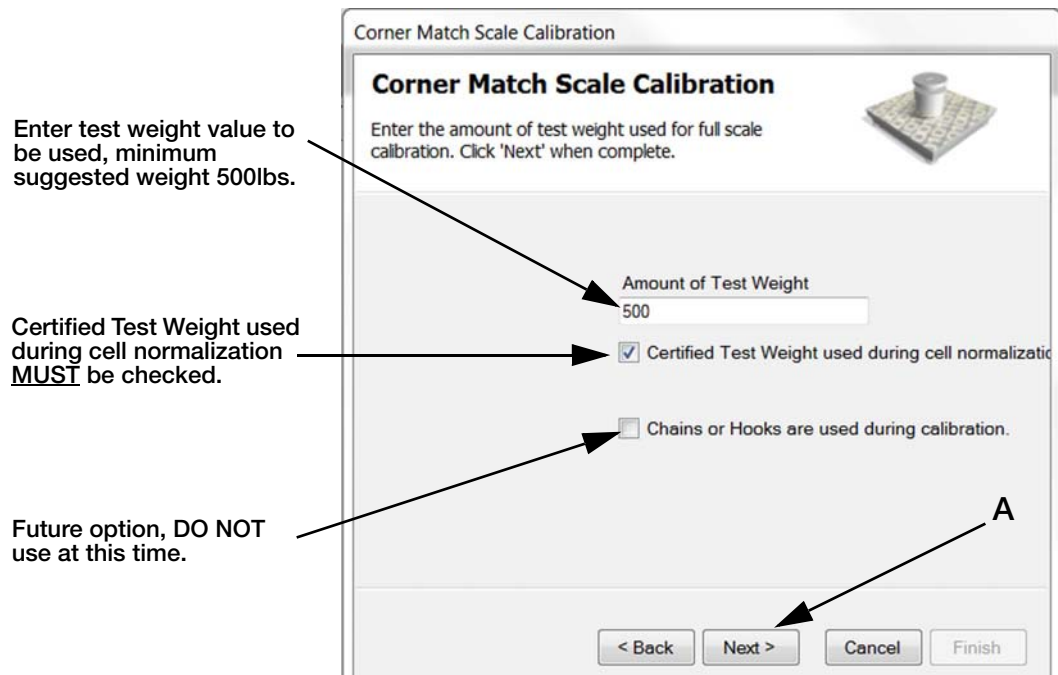

Figure 4-10. Enter Test Weight Value

4. Corner Match Scale Calibration screen appears. Press **Calibrate Zero** (Figure 4-11 A).
5. When message in the lower left corner of message box reads **Zero Calibration Complete** press **Next** (Figure 4-11 B).

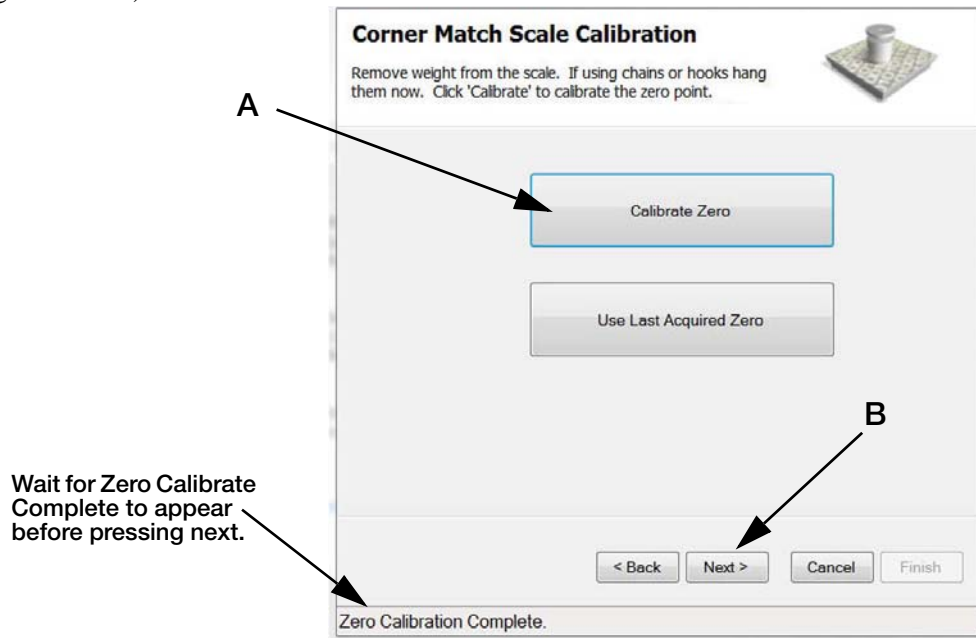
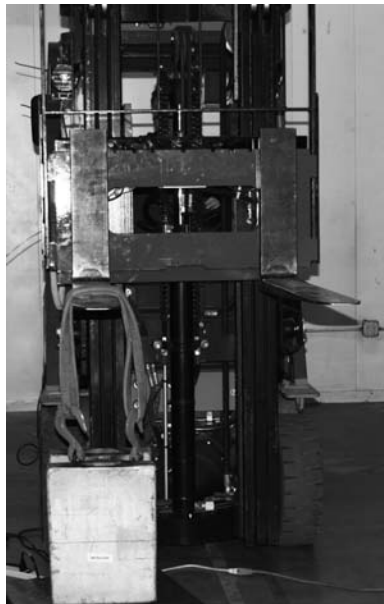

Figure 4-11. Calibrate Zero

6. Add known weight to load cell 1 (left hand load cell, see Figure 4-12).
7. Lift weight (allow it to stabilize if using hanging weight).



Note Always shut forklift off when calibrating, high vibration can cause inaccuracies. Make sure to calibrate forks in correct order, or the calibration will not be successful.



Load Cell #1
(Left Hand)

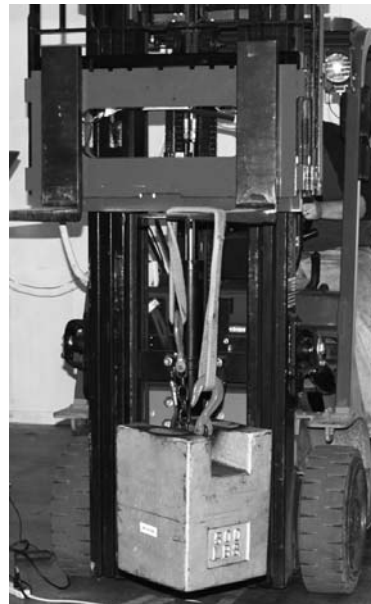

Load Cell #2
(Right Hand)

Figure 4-12. Load Cell #1 & #2

8. Press *Measure* (Figure 4-13 A).

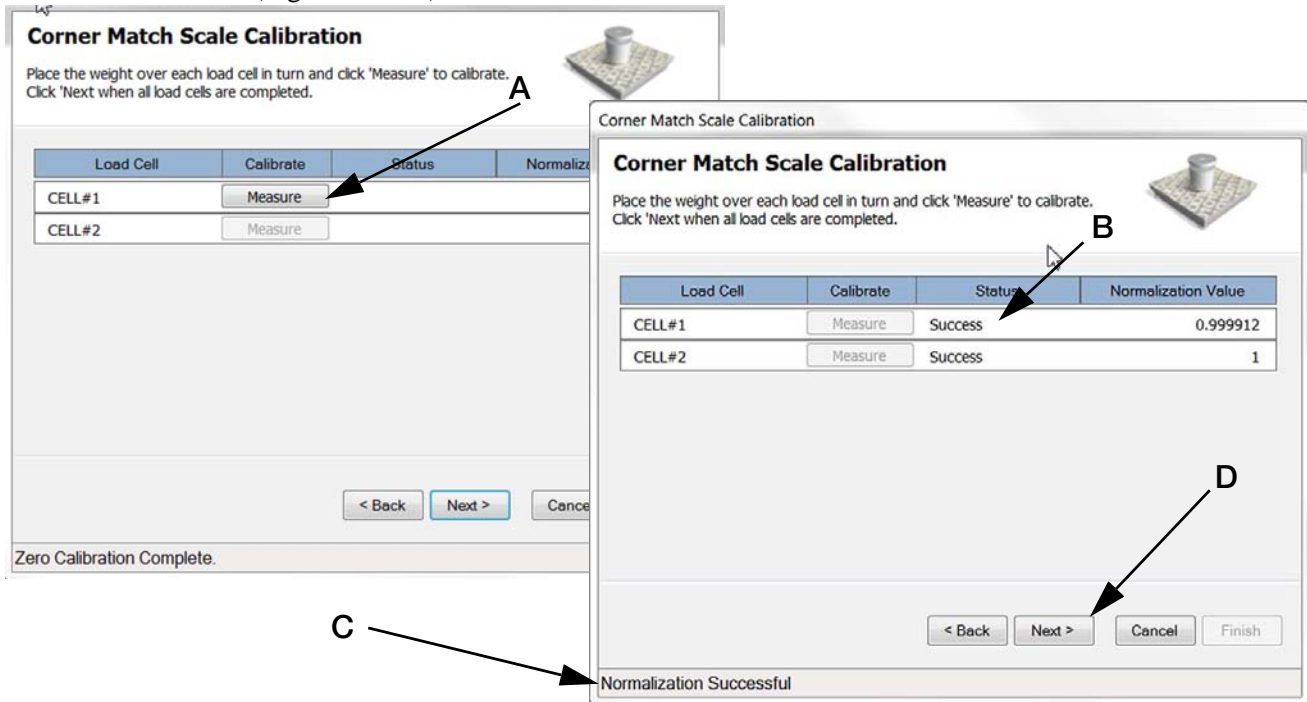

Figure 4-13. Load Cell Calibration

9. Load Cell #1 Status will read **Success** (Figure 4-13 B) and Load Cell #2 *Measure* will become available. Repeat steps 9-11 for Load Cell #2.
10. When both load cells have been calibrated (status reads Success for both Cell #1 & #2, Figure 4-13 B) and the **Normalization Successful** message appears (Figure 4-13 C) press **Next** (Figure 4-13 D).
11. The message stating successful calibrated of the scale appears (Figure 4-14 A).
12. Press **Finish** (Figure 4-14 B).
A message appears in the bottom of the frame **Getting New Calibration** (Figure 4-14 C). When done the pop up box will disappear and calibration is complete.

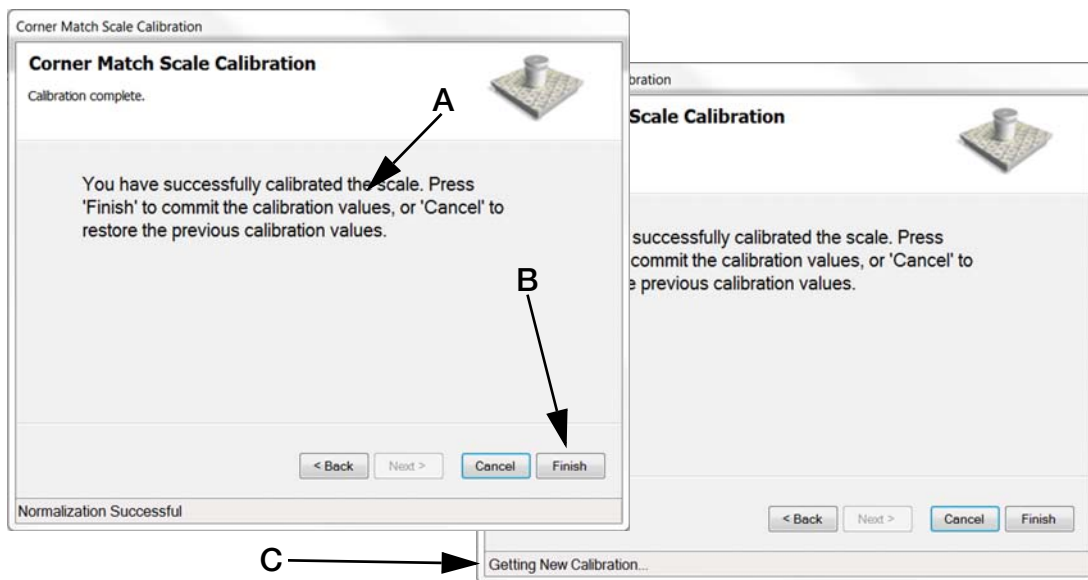

Figure 4-14. Finish Calibration

13. Place the calibration switch into the closed position (Figure 5-1), toward the left hand side of j-box when standing in front of the scale (toward load cell #1).

4.4.1 Reading Data In Live Weight Screen

Once calibration is complete, select the *Live Weight Data* tab.

Weight value with weight applied to forks

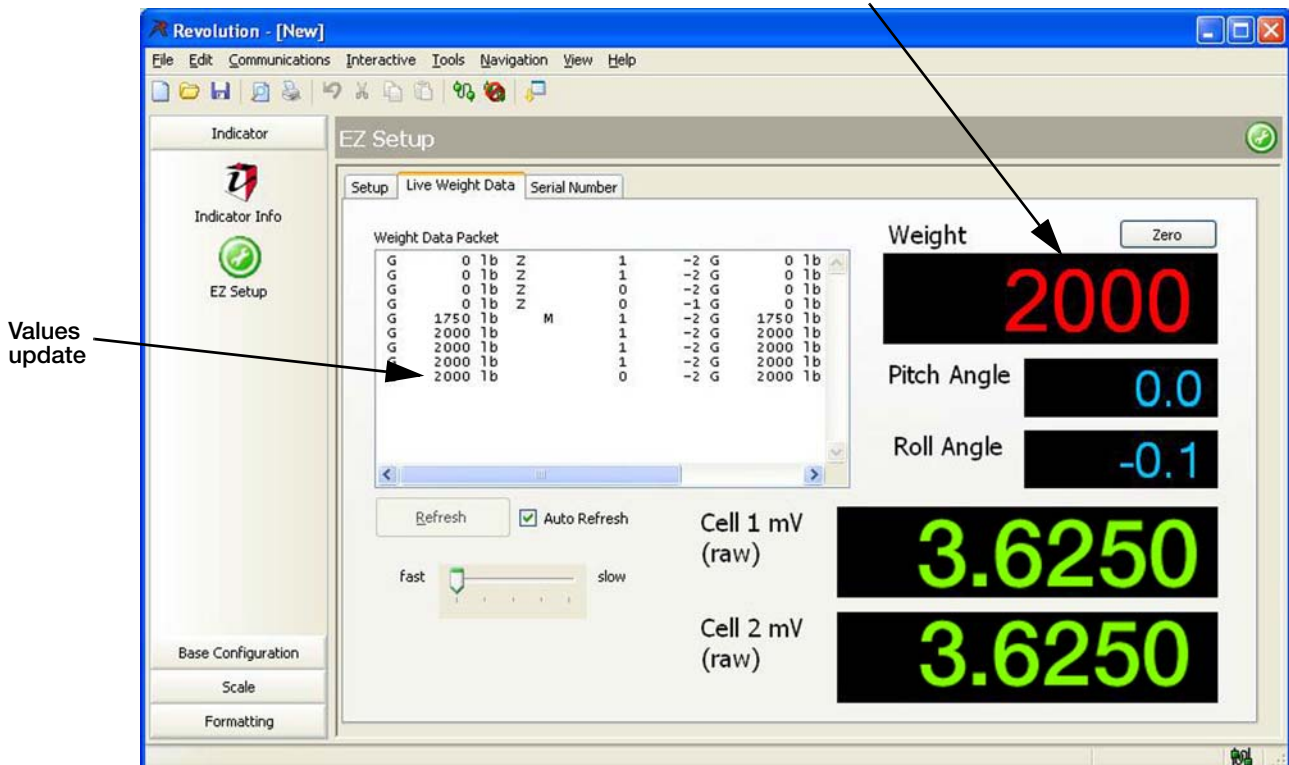

Figure 4-15. Revolution Live Weight Data Screen.

1. Place calibration switch into the closed position (Figure 5-1), toward the left hand side of j-box when standing in front of the scale (toward load cell #1).
2. Test known weight amounts as specified in Section 4.1. When weight is on fork the value will appear in the *Weight* box and the *Weight Data Packet* values will update.
3. If scale is weighing correctly, carefully disconnect USB and replace clear cover.
4. Swivel the cover plate back to the correct position and secure with screw.
5. Upon successful installation and calibration verification, seal the carriage j-box and load cell quick disconnects for Weights and Measurements approval.
6. Re-install the scale cover plate (Section 2.0, Figure 2-6). The scale is now ready for use.

4.5 EZ Setup/Upload Unit Serial Number

Figure 4-16 appears with three tabs, *Setup*, *Live Weight Data* and *Serial Number*. *Serial Number* will be used for entering the current serial number of the scale in the following sections.



Note All settings have been preset at the factory for communication with the hand-held device. DO NOT alter these settings, it will cause communication failure with the hand-held device.

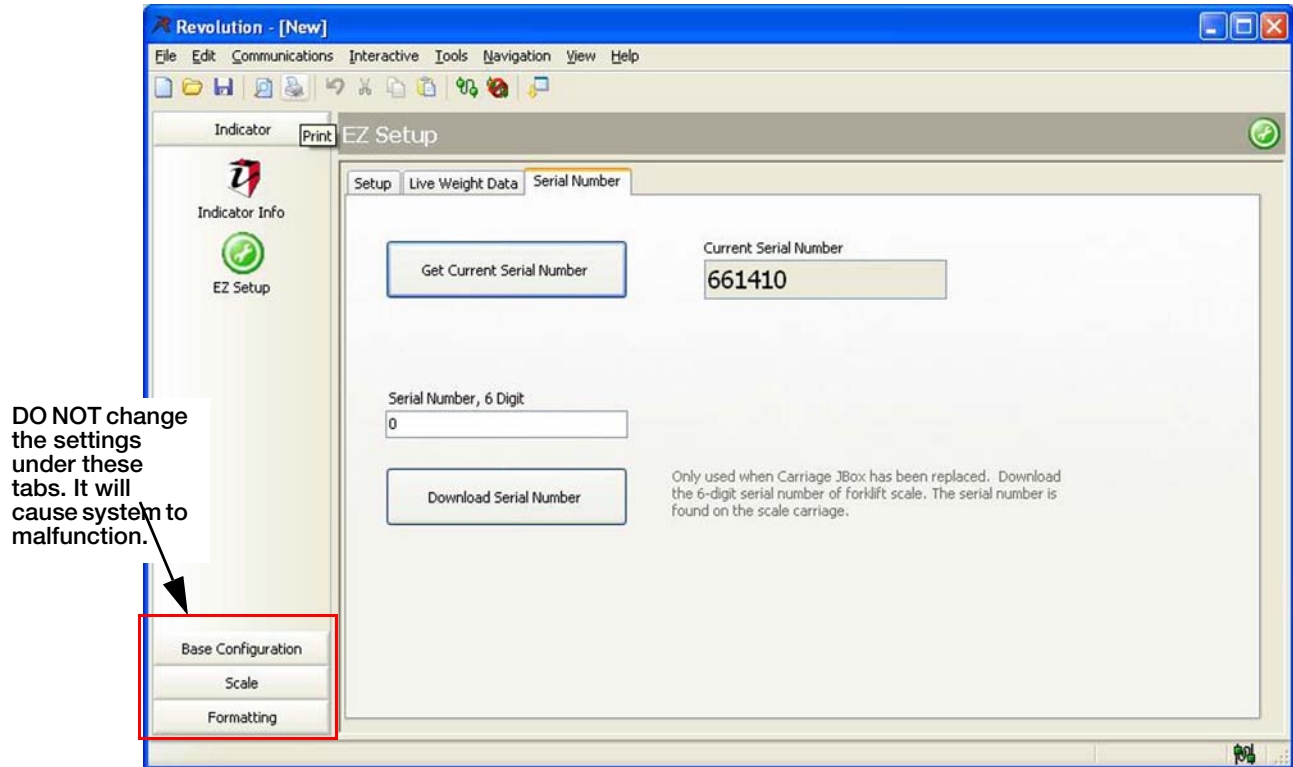

Figure 4-16. EZ Setup Screens - Setup

1. To check the serial number of the scale using Revolution, while in the *EZ Setup* mode, select the *Serial Number* tab.
2. Select the **Get Current Serial Number** button to get the current serial number.
3. If the j-box has been replaced and a new serial number must be entered, enter the new 6-digit serial number from the forklift scale (A) and press the **Download Serial Number** button (B) to save the new serial number. Once the serial is download, a message *Serial Number sent to device* is displayed on the screen and press **OK** to accept that number.



Note The serial number of the scale is pre-loaded in the j-box at the factory, It does not need to be downloaded during installation. If j-box is ever replaced (See Section 7.0 on page 42) this procedure will need to be repeated.

The serial number of the scale is located on the right side of carriage and also under the black cover plate on the scale assembly.

The serial number (a 6 digit entry) screen typically displays 0 or the last serial number downloaded.

If installing a new serial number, un-install the existing Revolution software program prior to upgrading.

The upload and download of each configuration file is no longer required. The iQube2 j-box has default factory settings to communicate with the CLS-M forklift scale.

4.6 Diagnostics

Diagnostics works in setup or normal operating mode.

1. On *EZ Setup* screen select *Diagnostics*.

 **Note** Selecting *Auto refresh* will continuously display data communications for each screen.

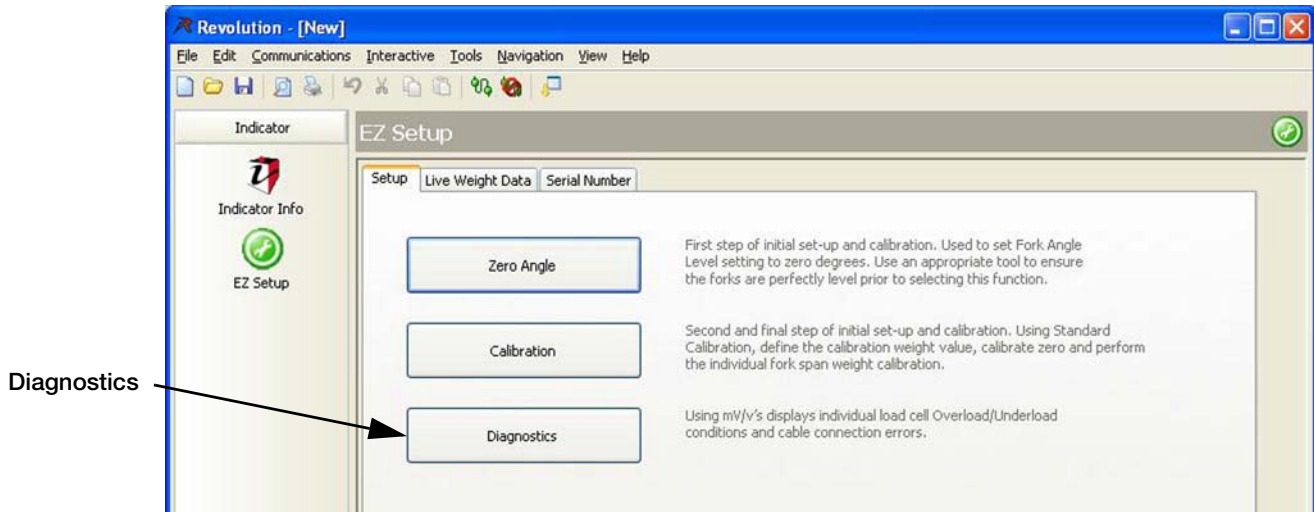
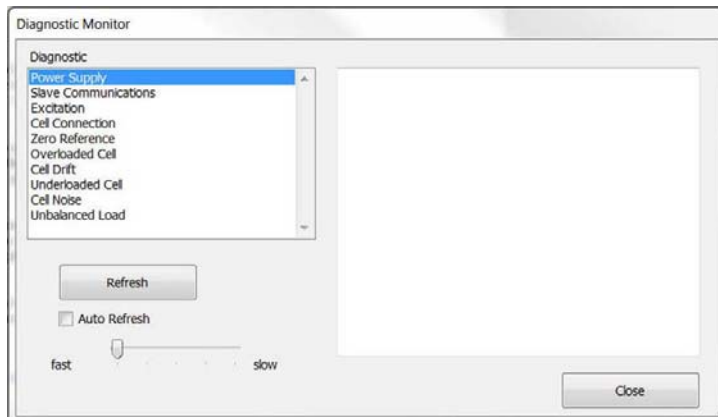

Figure 4-17. Select Diagnostics



Power Supply:
Not Applicable to CLS M software



Slave Communications:
Not applicable to CLS M software

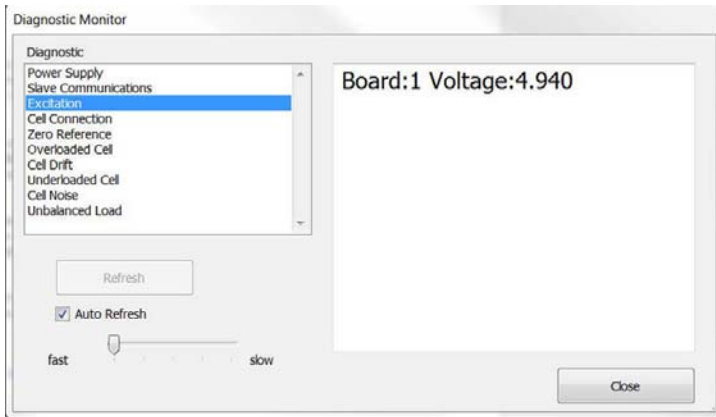

Excitation:
Not Applicable to CLS M software

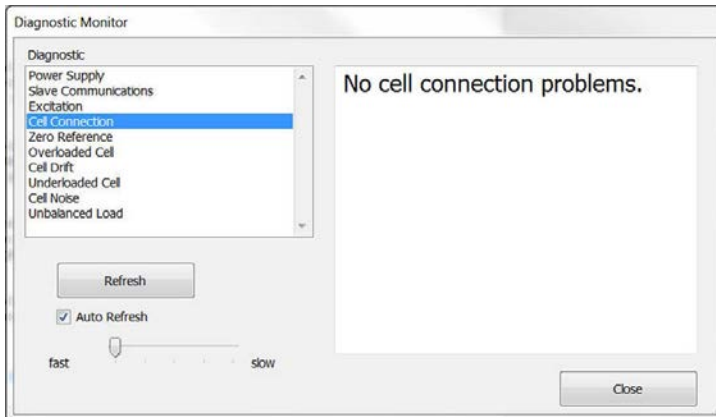

Cell Connection:
Tests correct load cell cable connections
Scans each load cell to display connection issues
If one load cell connection error is found, will flash between "No cell connection problems" and Scale: SC1 Cell:1 or 2. While standing in front of the forklift cell 1 is located on the left, cell 2 on the right.

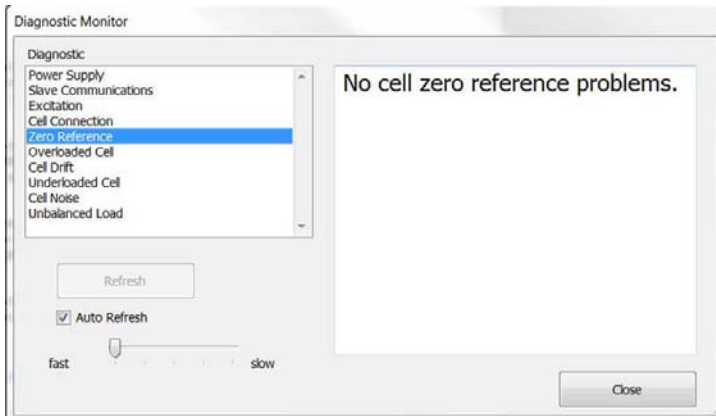

Zero Reference:
Not Applicable to CLS M software

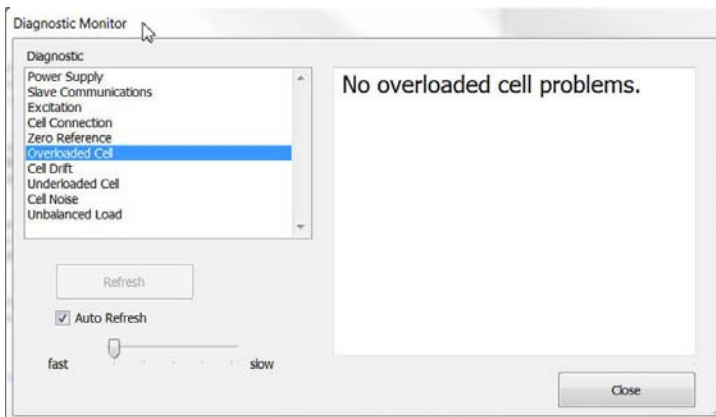

Overload Cell:
If error occurs displays mV level of the overloaded load cell.
At 5000lbs the mV rating is 1.5

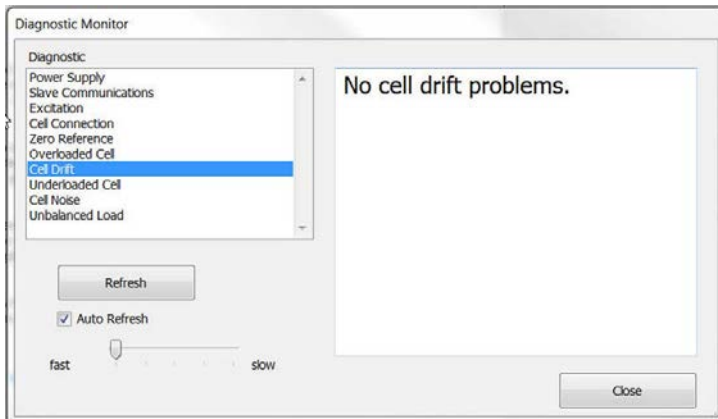

Cell drift:
Not Applicable to CLS M software

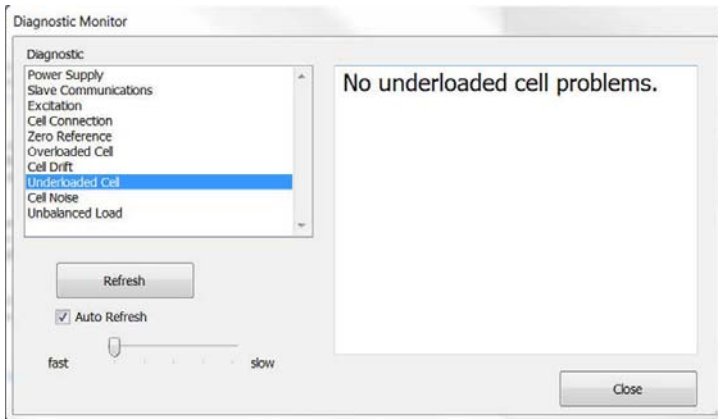

Underloaded Load cell:
If error occurs displays mV level of the underloaded load cell.
At 5000lbs the mV rating is 1.5

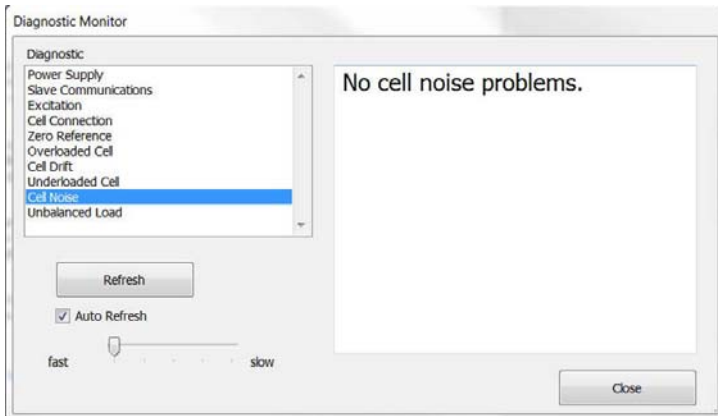

Cell Noise:
Not Applicable to CLS M software

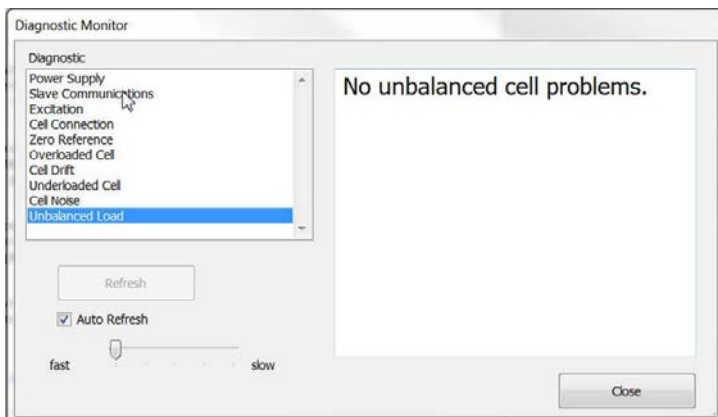

Unbalanced Cell:
Not Applicable to CLS M software

5.0 Calibration



Note When hanging weights from the forks make sure to note the weight of hanging device and add to test weight value (Figure 5-4).

Make sure forks are level before beginning calibration (See Section 4.3).

Suggested test weight is 500lb minimum.

Always shut forklift off when calibrating, high vibration can cause inaccuracies.

When going through calibration steps, it is recommended that you do not use the back button, calibration may not complete.

5.1 Carriage J-Box Calibration Mode

The load cell j-box must be placed in the calibration mode:

1. Remove the scale cover, if attached (Section 2.0, Fig Figure 2-6).
2. Remove one screw from the plate at the top of the j-box.
3. Swivel plate away from switch opening.
4. Place switch in the calibration position, away from coiled cable connection or toward the right hand side of j-box when standing in front of the scale (load cell 2).



Figure 5-1. J-Box Calibration Switch Location

5.2 Leveling Forklift Forks

1. Level the forks to 0° by placing a level on the forks and adjusting as required.



Note Carriage j-box will need to be in setup mode (See Section 5.3)

Turn off the forklift after leveling forks, high vibration from the running engine will cause inaccurate readings.

2. In the setup screen, press Zero Angle (Fig 5-2 A).
3. A pop-up appears as shown in (Fig 5-2 B), press OK to close pop-up box.

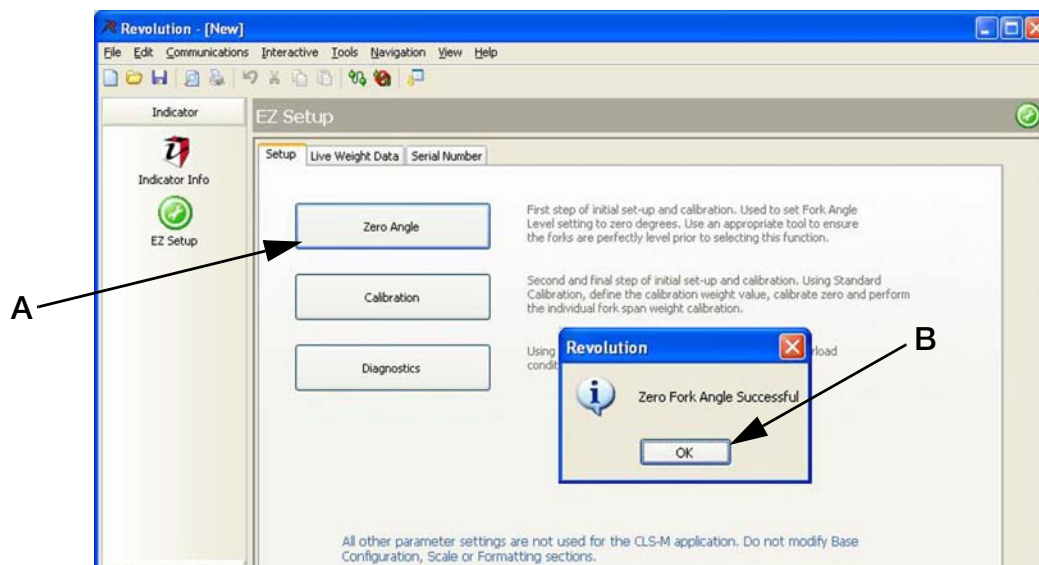

Figure 5-2. Zero Forks



Note Forks should be level when testing calibration. A degree of tilt in either direction can cause errors in the use of the scale.

5.3 Calibrate Scale Using Revolution

1. Connect computer to adapter on the coiled interface cable (see Section 3.3).
2. Level forks (see Section 5.2).
3. In set-up select **Calibration** (Figure 5-3 A).
4. Select **Standard Calibration** (Figure 5-3 B)
5. Press **Next** (Figure 5-3 C).

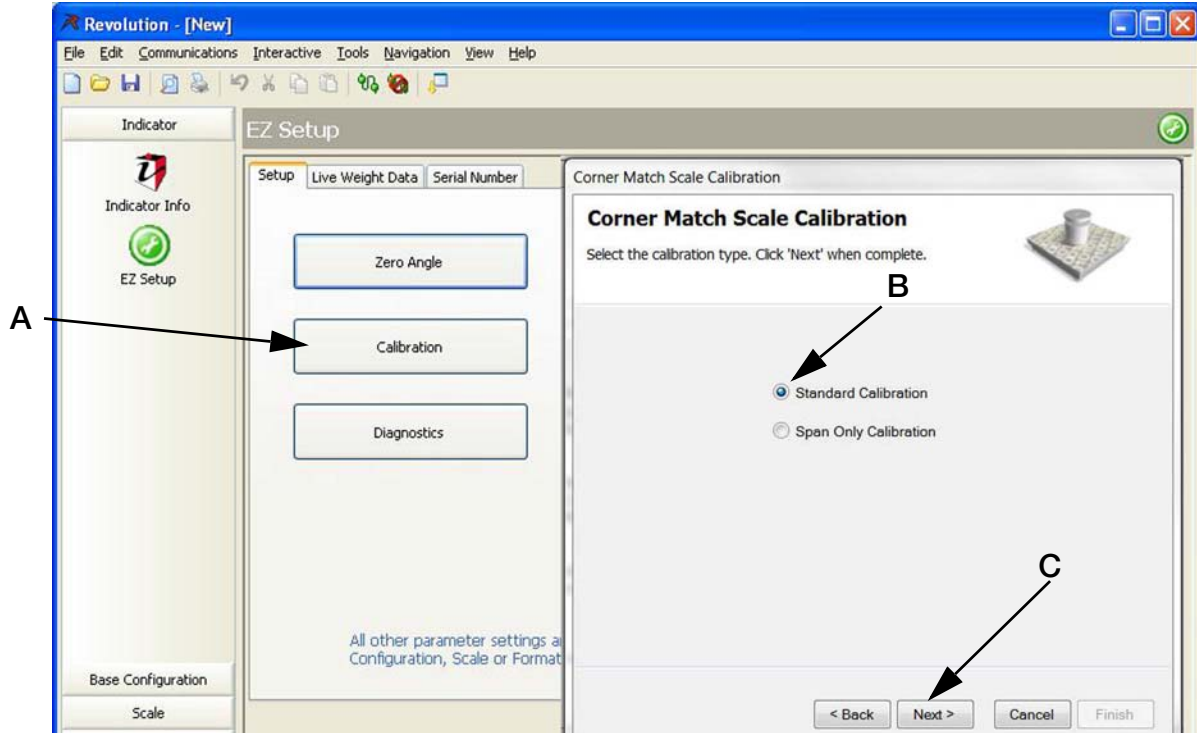

Figure 5-3. Enter Calibration

6. Enter test weight value to be used and press **Next** (Figure 5-4 A).
Certified Test Weight used during cell normalization must be checked.

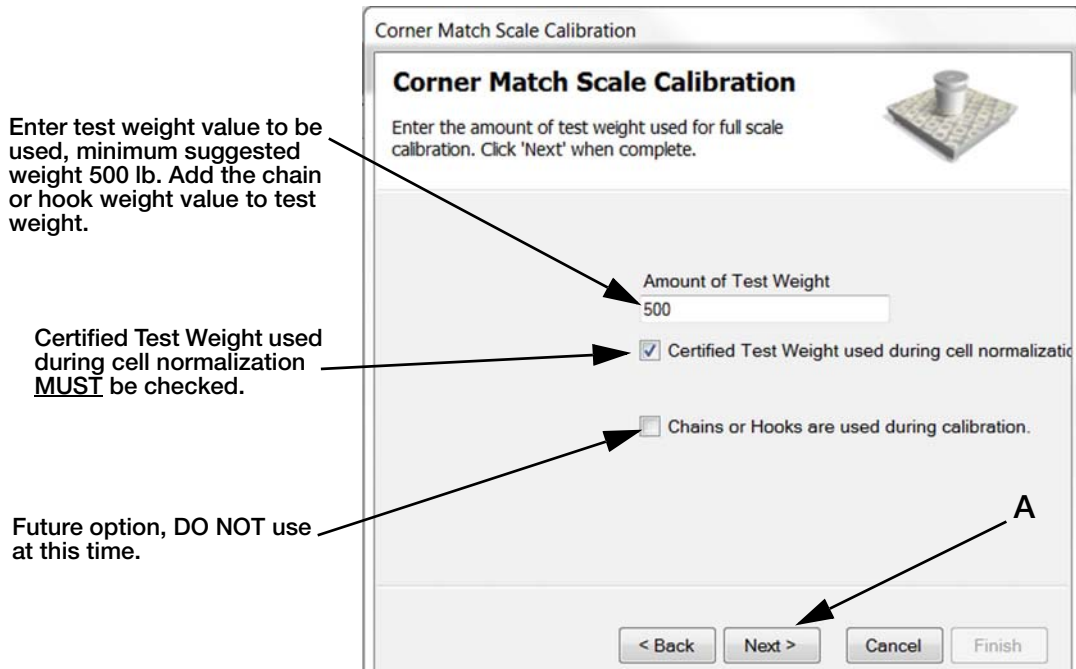

Figure 5-4. Enter Test Weight Value

7. **Corner Match Scale Calibration** screen appears. Press **Calibrate Zero** (Figure 5-5 A).
8. When the message in the lower left corner of message box reads **Zero Calibration Complete** press **Next** (Figure 5-5 B).

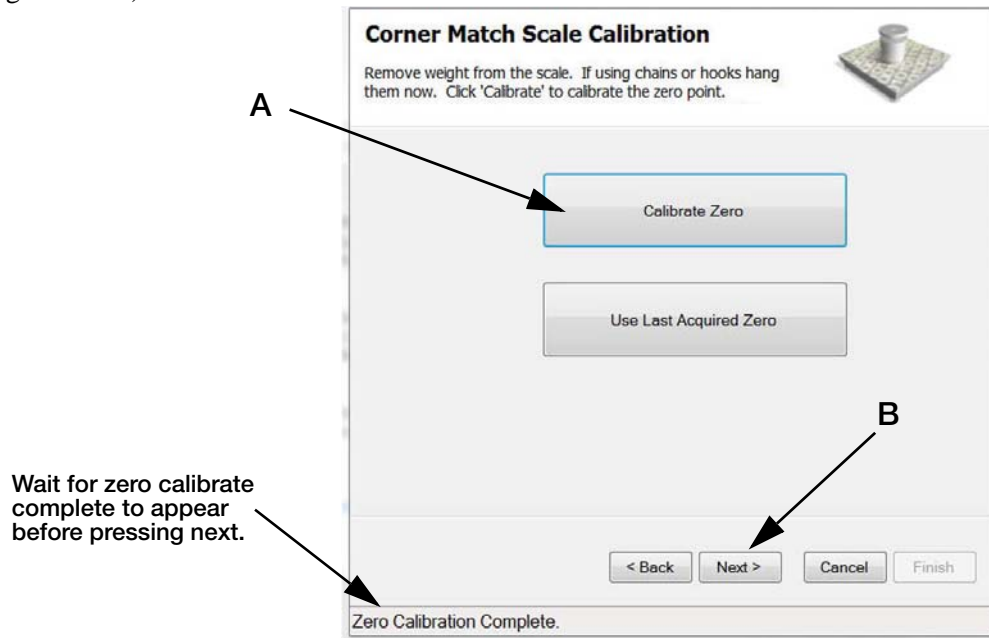
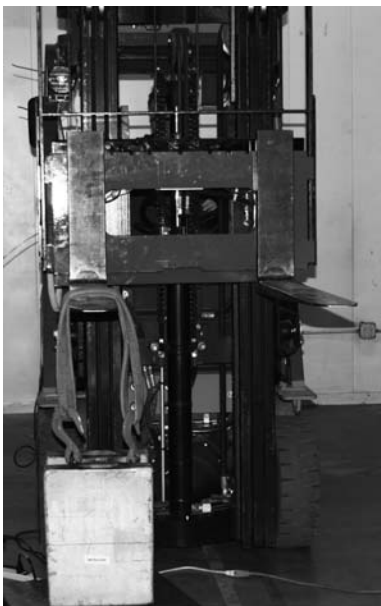

Figure 5-5. Calibrate Zero

9. Add known weight to load cell 1 (left hand load cell, see Figure 5-6).
10. Lift weight (allow it to stabilize if using hanging weight).



Note *If possible shut forklift off when calibrating, high vibration can cause inaccuracies. Make sure to calibrate forks in correct order or the calibration will not be successful.*



Load Cell #1
(Left Hand)

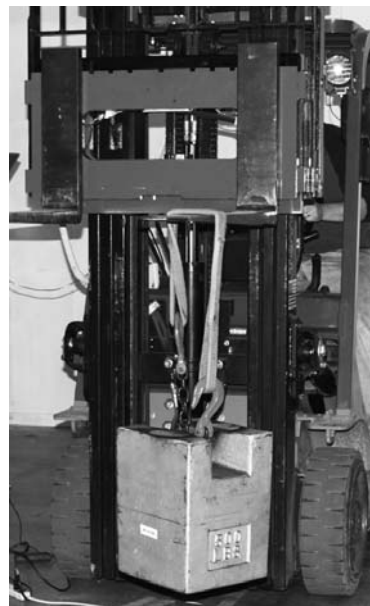

Load Cell #2
(Right Hand)

Figure 5-6. Load Cell #1 & #2

11. Press **Measure** (Figure 5-7 A).

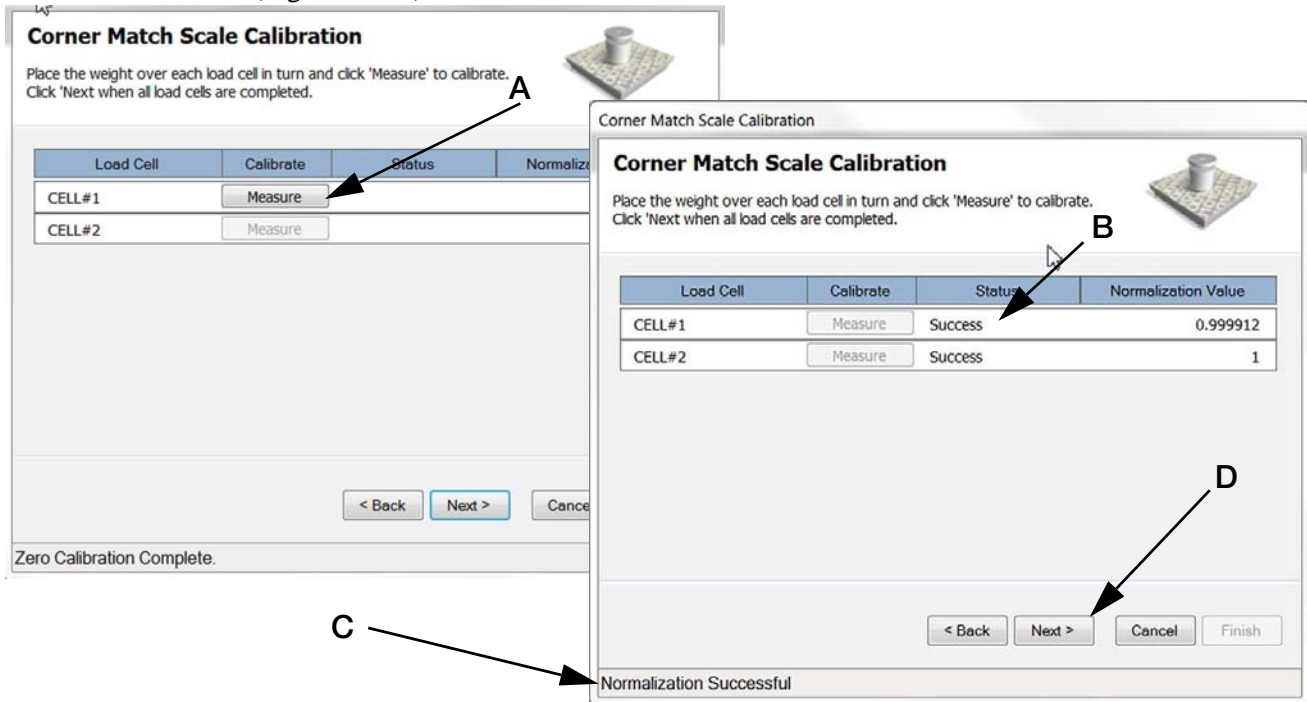

Figure 5-7. Load Cell Calibration

12. Load Cell #1 status will read **Success** (Figure 5-7 B) and Load Cell #2 **Measure** will become available. Repeat steps 9-11 for Load Cell #2.
13. When both load cells have been calibrated (status reads **Success** for both Cell #1 & #2, Figure 5-7 B) and the **Normalization Successful** message appears (Figure 5-7 C) press **Next** (Figure 5-7 D).
14. A message that you have successfully calibrated the scale will appear (Figure 5-8 A) then press **Finish** (Figure 5-8 B).
A message appears in the bottom of the frame **Getting New Calibration** (Figure 5-8 C). When done the pop up box will disappear and calibration is complete.

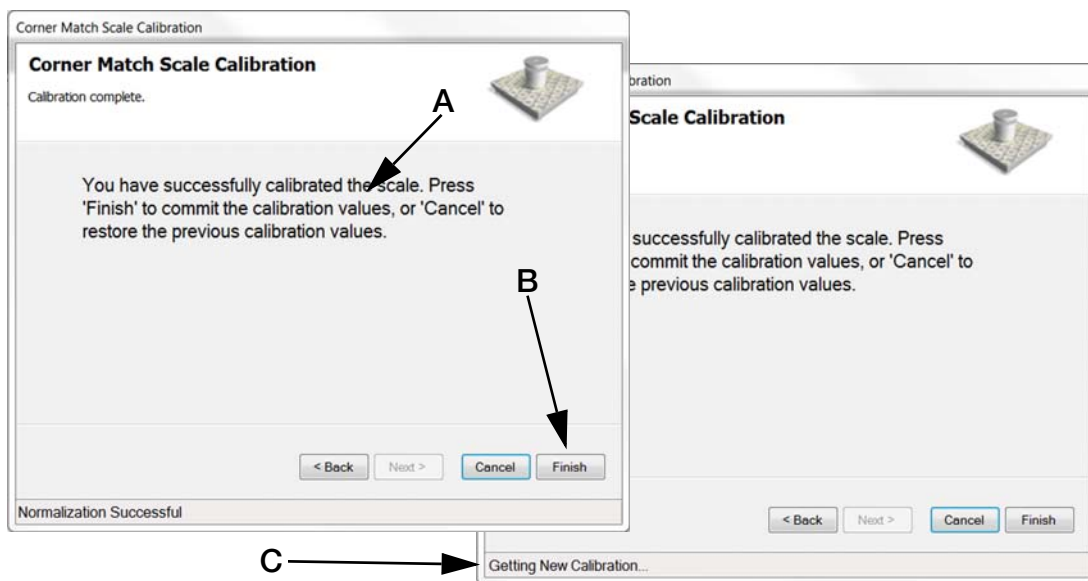

Figure 5-8. Finish Calibration

15. Place calibration switch into the closed position (Figure 5-1), toward the left hand side of j-box when standing in front of the scale (toward load cell #1).

5.3.1 Reading Data In Live Weight Screen

Once calibration is complete select the *Live Weight Data* screen.

Weight value with weight applied to forks

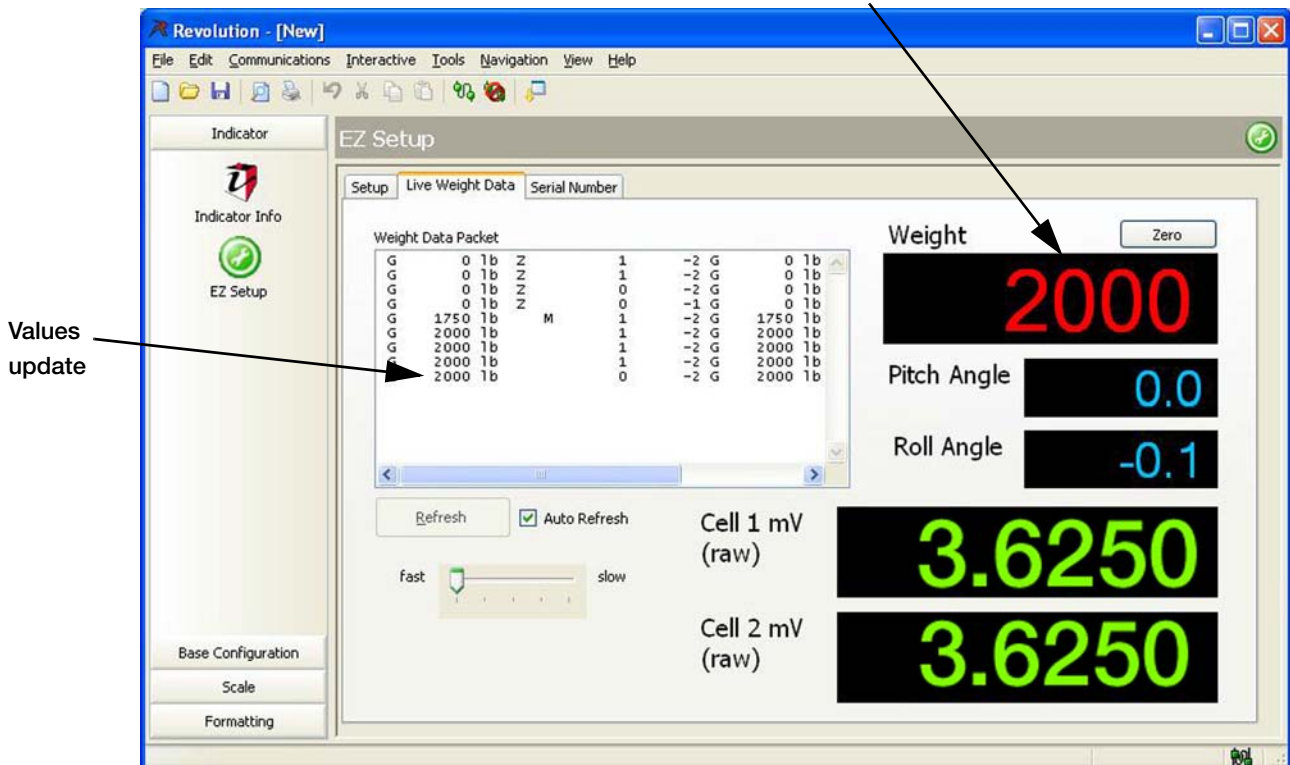
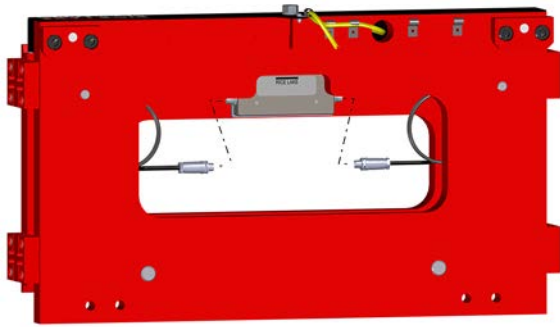

Figure 5-9. Revolution Live Weight Data screen.

1. Place calibration switch into the closed position (Figure 5-1), toward the left hand side of j-box when standing in front of the scale (toward load cell #1).
2. Check for accuracy as specified in Section 3.4. When weight is on fork the value will appear in the *Weight* box and the *Weight Data Packet* values will update.
3. If the scale is weighing correctly carefully disconnect USB and replace clear cover.
4. Swivel the cover plate back to the correct position and secure with screw.
5. Upon successful installation and calibration verification, seal the carriage j-box and load cell quick disconnects for Weights and Measurements approval.
6. Re-install the scale cover plate (Section 2.0 Figure 2-6). Scale is now ready for use.

5.4 Weights and Measures Sealing

Weights and Measures personnel will inspect the j-box for proper sealing once installed on the forklift. The j-box must have the proper serial tag affixed to the box and lead wire sealing on the j-box.



View from back of scale



Weights and Measure seals

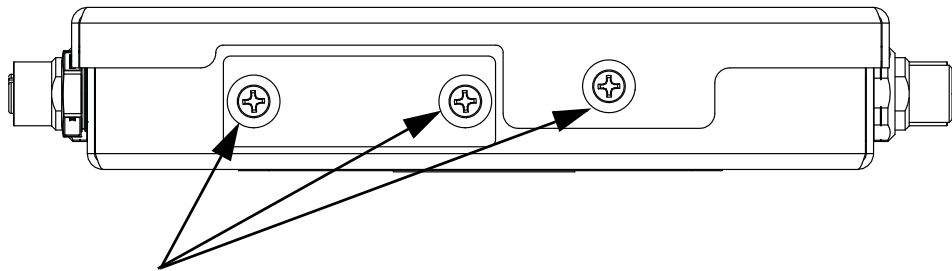

Weights and Measures sealing location

Figure 5-10. Sealing the J-Box for Weights and Measures

6.0 Load Cell Replacement and Flexure Troubleshooting

This section describes procedures for replacing a load cell. The *CLS-M Cargo Lift Scale* uses Rice Lake's load cell, PN 125543.

The following instructions must be followed exactly to allow for seamless and easy load cell replacement.



Take all necessary safety precautions when installing or replacing the scale parts including wearing safety shoes, protective eyewear, and using the proper tools.

6.1 Required Tools for Replacing a Load Cell

The following list of tools is necessary for replacing a load cell on the *CLS-M* scale. Ensure that you have these tools handy.

| Rice Lake Part # | Item Description |
|------------------|-------------------------------------|
| 96196 | Modified box wrench |
| | Crescent wrench |
| | 3/4" socket wrench, with extensions |
| | ball-peen hammer |
| | 1-1/8" wrench for overload stop |
| | Chisel |
| | Allen wrench for overload stops |
| | Torque wrench |
| | Pry bar |

Table 6-1. Required Tools for Replacing a Load Cell



Note *Adequate light is necessary to change the load cell. Try to position the forklift close to a good source of natural light or if not possible, have a good source of lighting available.*

6.2 Load Cell Replacement

A replacement parts kit is available (PN 97883), which contains all of the component parts shown in Figure 6-1.

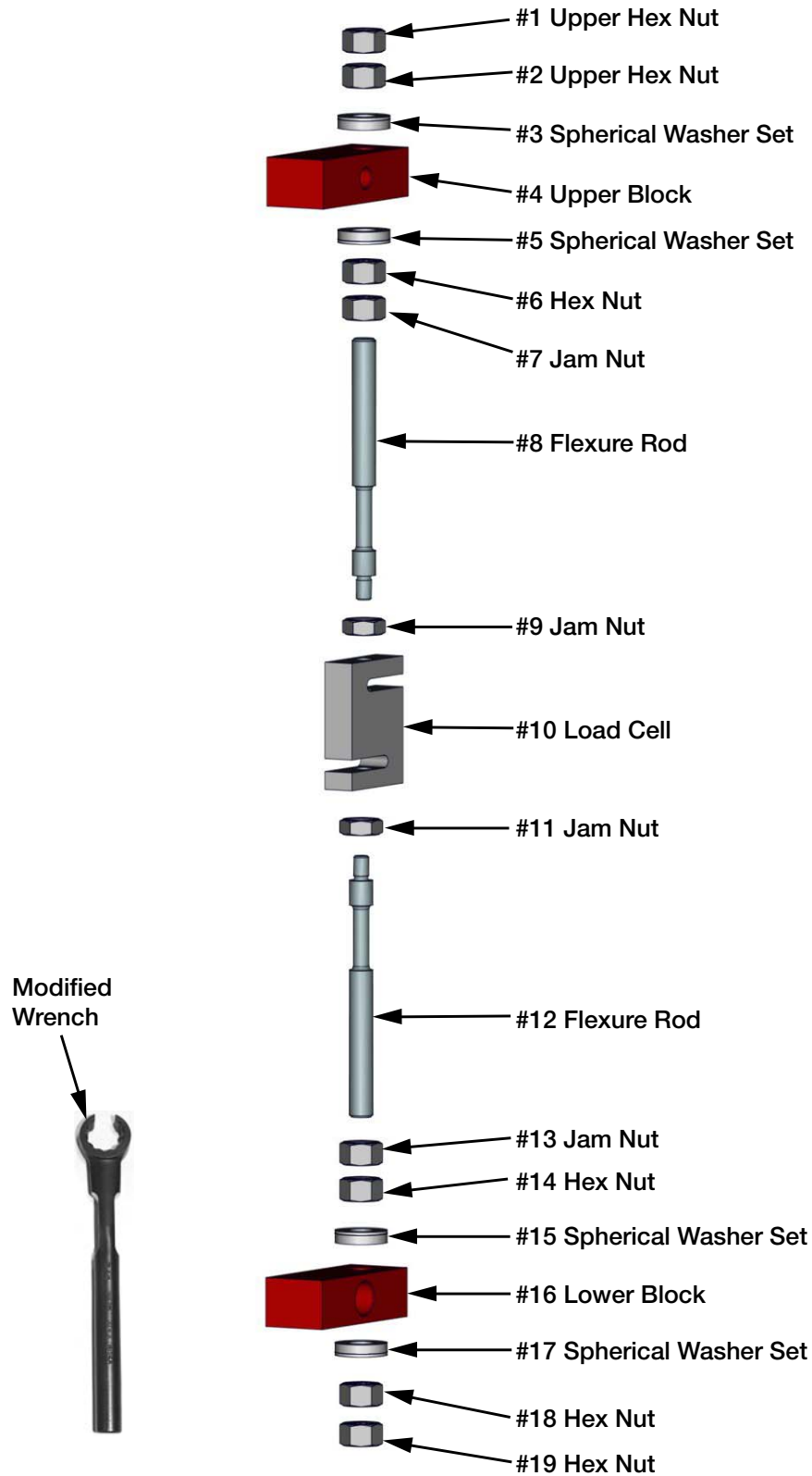
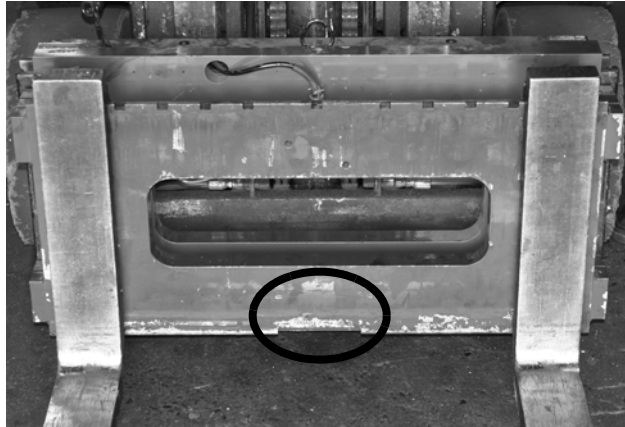

Figure 6-1. CLS-M Load Cell Assembly Parts Breakout

Use the following steps to replace a load cell.

1. Raise the forklift carriage just slightly for fork removal.
2. Slide the forks to the center of the carriage to allow for removal. Set forks aside.



Slide forks to the middle of scale carriage



Figure 6-2. Fork Removal

3. Raise the forklift carriage to a comfortable working height for the load cell replacement.
4. Remove the top hex nut (#1) with a socket wrench.



Note It's okay if the load cell slightly rotates up against the front or back plate of the scale.



Figure 6-3. Removal of Hex Nut (#1 of Parts Breakdown)

5. Loosen jam nut (#7) from the upper block using the special modified box wrench (PN 96196 - supplied with load cell replacement kit) and shown in Figure 6-1.
6. Loosen jam nut (#13) from the lower block.
7. Remove the top hex nut (#2) and the top spherical washer set (#3).



Figure 6-4. Loosen and Remove Bottom Hex Nut (#18 and #19 on Parts Breakdown)



Note It's okay if the load cell slightly rotates up against the front or back plate of the scale.

8. Remove the bottom hex nuts (#18 and #19) and the bottom spherical washer set (#17).
9. Loosen the hex nut located under the upper block (#6).
10. Loosen the jam nut located on top of the load cell (#9).
11. Loosen the hex nut (#14) located on top of the lower block.
12. Loosen the hex nut (#11) on the lower side of the load cell.
13. Remove the bottom flexure rod (#12) and the top flexure rod (#8) sliding the remaining washer sets (#5 and #15) with it.



Ensure flexure rod threads are free of debris and paint by running a nut the full distance of the rod.

Figure 6-5. Remove Flexure Rod with Nuts and Washers

14. Check the flexure rod threads for smooth operation by running a nut the full distance of the rod, making sure it does not get stuck anywhere along the way. If so, clean off any paint using a wire brush and oil.
15. Oil the spherical washers using a standard machine shop oil.
16. Disconnect the load cell cable from the junction box.
17. Loosen cable clips and remove the load cell.

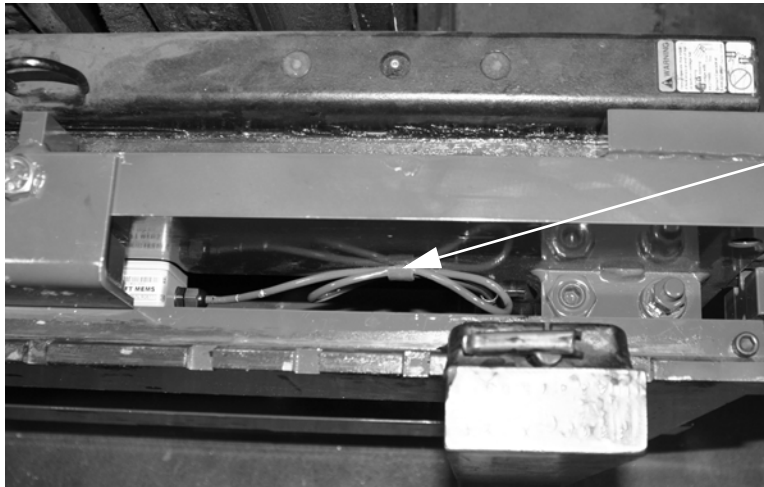

Detach load cell clip from back plate of scale using a large screwdriver.

Figure 6-6. Load Cell Cable Clips

18. Position a new load cell with its cable facing towards the center and opening of the S-beam facing the flexure's.

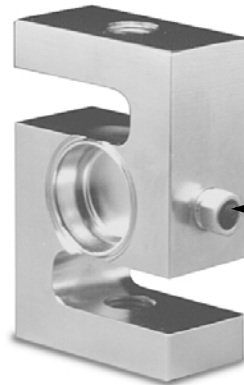

Load cell cable should face towards the center of the scale.

Figure 6-7. Load Cell

19. Install the top and bottom flexure rod with hardware, ensuring that the flexure rod be oriented with the short thread of the rod facing nearest the load cell.



Figure 6-8. Installing Flexure into Scale

20. Insert the load cell and thread flexure rods into top and bottom of the load cell making sure the appropriate hex nuts, jam nuts, and spherical washers are in the correct order per Figure 6-1 on page 34.
21. Screw in the rod and tighten jam nut but, leave approximately two threads exposed outside of the jam nut. Do both the top and bottom of the load cell.
22. Use hex nuts to position the load cell in the center of the mounting blocks with an equal amount of flexure rod on the top and bottom of the load cell.
23. Tighten the jam nuts on the top and bottom of the load cell, making sure they are tight, and load cell is completely vertical with the scale. To accomplish this, you can use a pry bar or chisel to hold the cell straight as illustrated in Figure 6-9.

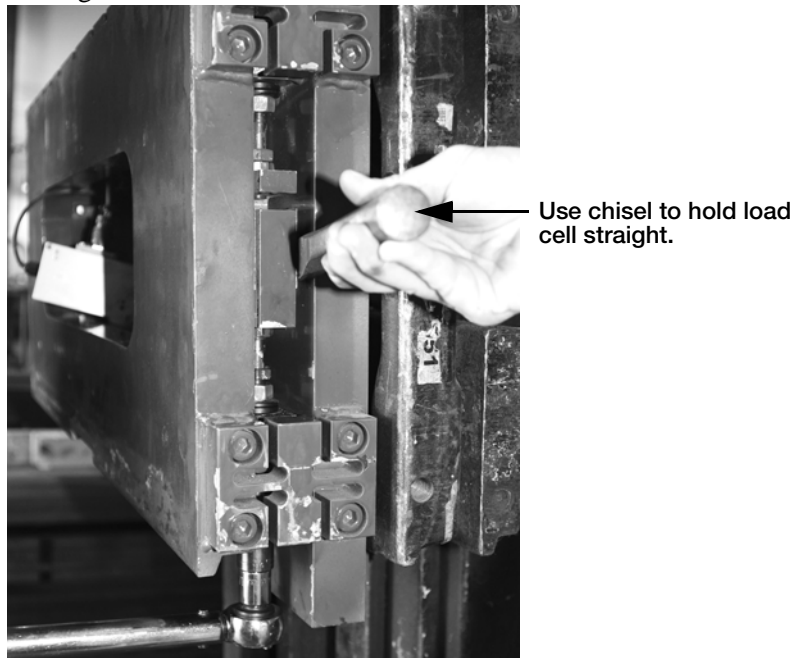

Figure 6-9. Use Chisel to Hold the Load Cell in Straight

24. Install the spherical washer set and hex nut on the bottom flexure rod, ensuring that the fat washer is mounted towards the mounting block.

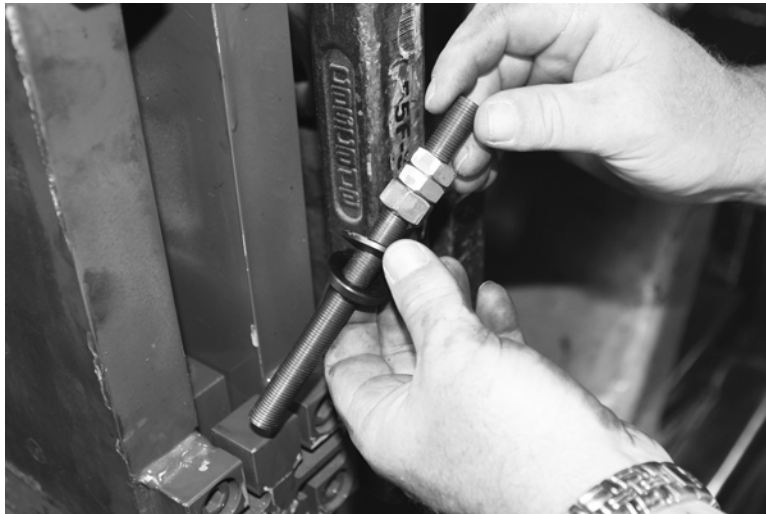
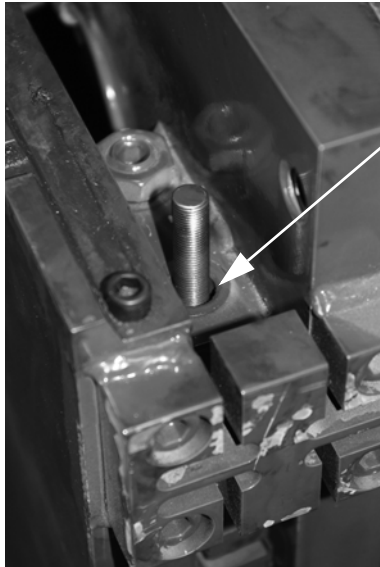

Figure 6-10. Install Spherical Washer Set

25. Install a flat-bladed screwdriver in the upper mounting block between the hole and the flexure rod, forcing the flexure rod in the same direction of the flexures.



Insert the flat-blade screwdriver here to help center the flexure rod.

Figure 6-11. Centering the Flexure Rod

26. Use a pry bar or chisel to hold the load cell (bottom half of the cell), straight while using a torque wrench to tighten the bottom hex nut on the lower mounting block to 110 ft-lb. Install the other hex nut on the bottom of the flexure rod and torque it to 110 ft-lb.



Figure 6-12. Centering the Load Cell Using a Chisel



Figure 6-13. Tightening the Lower Hex Nut

27. Use the special modified box wrench to tighten the jam nut (#13) on the lower block.
28. Remove the flat-bladed screwdriver as used in Step 25 and inspect the flexure rod. The flexure rod needs to be in the center of the hole. If it is not, use a hammer and an angled diamond chisel to hit the bottom mounting plate and spherical washer set to adjust it to center.
29. Install the spherical washer set (#3) and hex nut (#2) on the top of the upper block.
30. Connect the load cell cable to the junction box at this time.
31. Torque the hex nut (#2) on the upper mounting block until you see 100 lb on the weight display. Tighten the lower hex nut (#6) below the upper mounting block using the modified box wrench and try to get the display as close to zero as possible.
32. Torque the top hex nut (#1) with a torque wrench to 110 ft-lb. Use a pry bar or chisel to ensure the load cell stays centered while tightening and doesn't touch the sides of front or back plate
33. Install the final hex nut on the top mounting plate and torque to 110 ft-lb. Use a pry bar or chisel to keep the load cell centered.
34. Tighten the jam nut on the lower mounting block assembly.
35. Exercise the scale, heel to toe, by placing a weight (1000 lb) on the heel, then the toe to check if the assembly was installed correctly. Do this for both sides. If the weight is off, check assemblies.
36. Place a weight in the center of the fork and check side to side values. If they are equal, you are done.
37. Calibrate the load cells (See Section 5.0 on page 46).

6.3 Forklift Flexure Troubleshooting - 28" and 34" Models

For Part Number 92828

The forklift flexure is designed to protect the load cell from damage in the forklift environment.

Use the following steps if the forklift scale is out of tolerance or unable to return to zero on a consistent basis.

1. Check for debris within the scale or between the scale carriage.
2. Check for proper spacing of the jam nuts at 0.02".
3. Check the dimensions of the flexure for damage. There should be a ± 0.03 " tolerance to the drawing shown below for height and width.

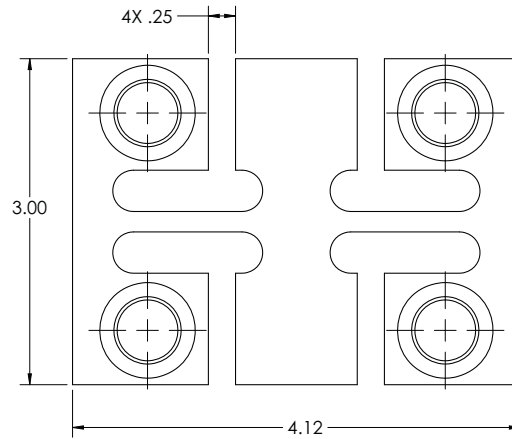

Figure 6-14. Flexure Chassis

7.0 iQube2® J-Box

The iQube2 j-box designed for use with the Rice Lake CLS-M series forklift scales and is a replacement for the j-box used on early models of the scale. Load cell connectors have been updated to improve serviceability.

7.1 iQube2 J-Box Replacement

The j-box is located between the front and back panel of the scale and is covered by a metal cover plate on the top of the scale.

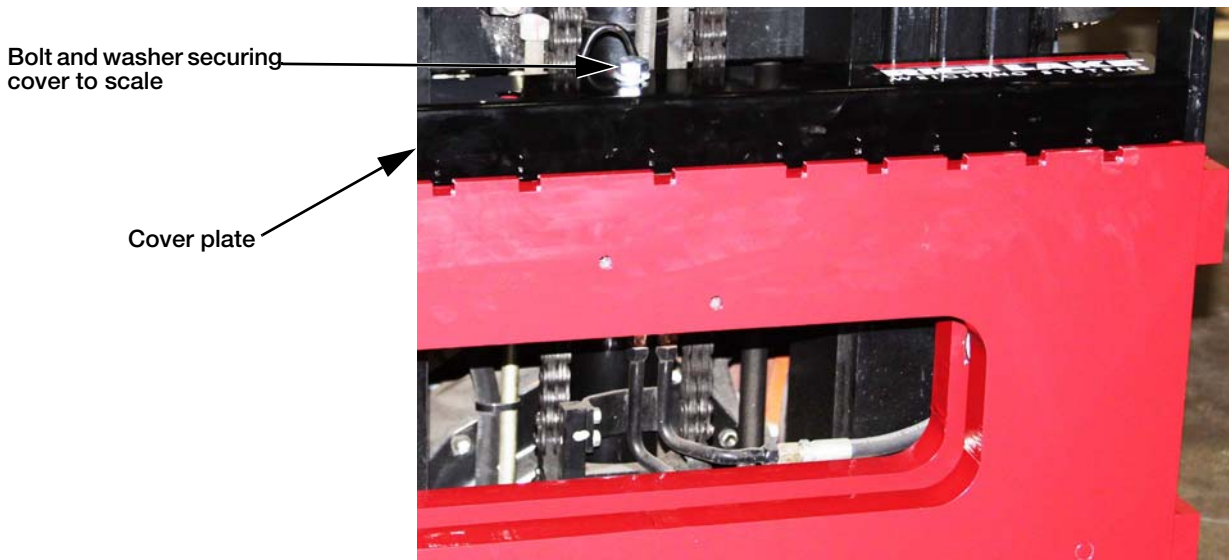



Figure 7-1. Remove Cover Plate

1. Turn scale power off on the Communication/Power box.
2. Remove the bolt that holds the cover plate in place, which conceals the junction box.
3. Remove the cover plate and set aside.
4. Unplug power cable.
5. Lift the forklift to a comfortable working height.
6. Remove the two screws securing the j-box to the scale, using a #4 metric Allen wrench, to remove existing j-box from scale carriage.
7. Remove the coiled interface cable from the junction box.
8. Disconnect the load cell cables.

 **Note** Steps 9-14 are only required when upgrading the original j-box to an iQube2. If replacing an iQube2 with another iQube2 skip to step 15.

9. Remove automotive quick connects from load cell cables.
10. Strip wires for connection to the new load cell connectors. See Figure 7-3.
11. Follow the instructions on the packaging for Turk connector, PN BS-8157-0/P69, for inserting wires.
12. Wire the load cell 5-pin male connector to the following color codes Table 7-1 and Figure 7-3. Note the orientation of the raised diamond in Figure 7-3. Use the supplied tool in the rectangular tool slot to lock wires down.

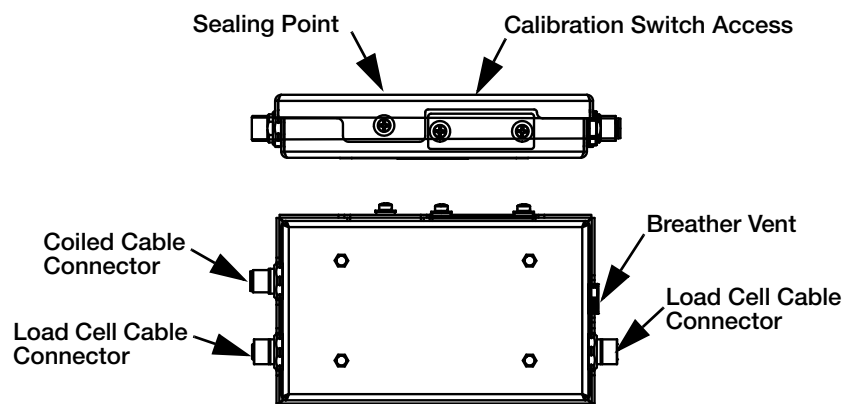
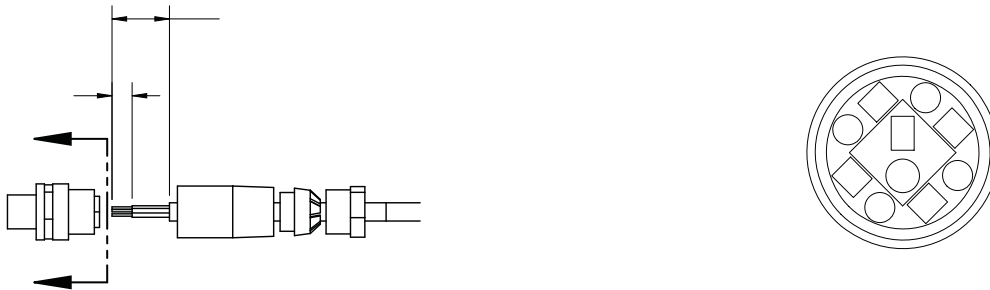

Figure 7-2. iQube2 J-Box

Load Cell 5 Pin Male Connector Wiring

| Pin # | Wire Color | Function |
|-------|------------|----------|
| 1 | Green | +SIG |
| 2 | White | -SIG |
| 3 | Red | +EXC |
| 4 | Black | -EXC |
| 5 | Yellow | Ground |

Table 7-1. Load Cell Wiring



Load Cell Stripping Wiring

Load Cell Wiring

Figure 7-3. Load Cell Wiring

13. Add blue Loctite[®] 425 to the two contact points as indicated in Figure 7-3.
14. Attach the load cell cables to the bottom two connectors on the junction box.
 - Apply Loctite.
 - Hand tighten until the connection is snug, plus another 1/4 turn. Only two threads should be visible.

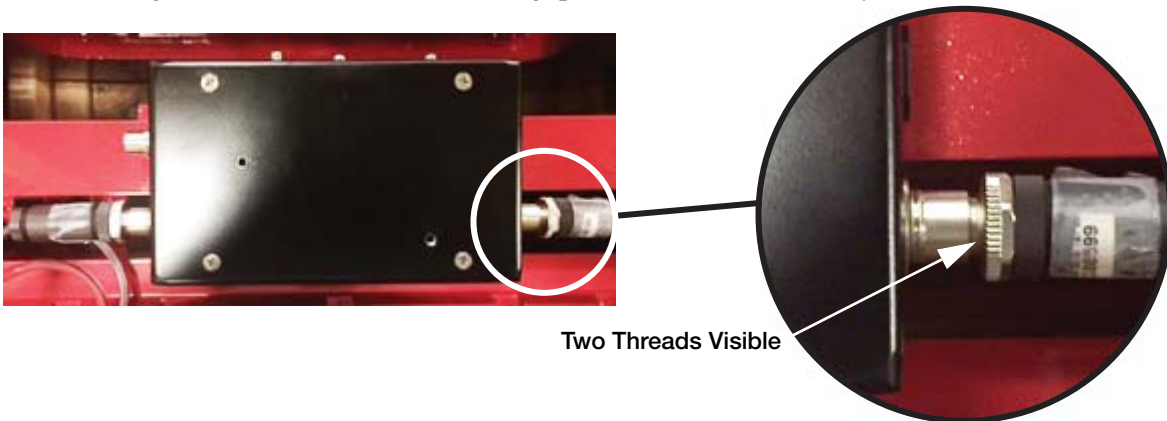

Figure 7-4. Connect Load Cell Cable to J-Box

15. Attach the home run cable to the top side connector.
16. Install the iQube2 j-box into the forklift scale, using Loctite on the mounting screws.
17. Open the calibration access switch cover on the j-box, set switch to the **On** position.
18. Plug in the power cable, and turn on the communication power box.
19. Calibrate the unit using Revolution software.
20. Connect the load cell cables to each side.
21. Connect the coiled interface cable to the top of the j-box.
22. Align the iQube2 j-box with the bolt holes in the scale and use an Allen wrench to tighten.
23. Place the cover plate in place and secure with a bolt and washer, and seal the unit.

1. Loctite[®] is a registered trademark of Henkel Technologies.

7.2 Download the Serial Number to the J-Box

1. To download the serial number of the scale using Revolution while in the *EZ Setup* mode, select the Serial Number tab.
2. Enter the new six-digit serial number from the forklift scale (A) and press the **Download Serial Number** button (B) to save the new serial number.

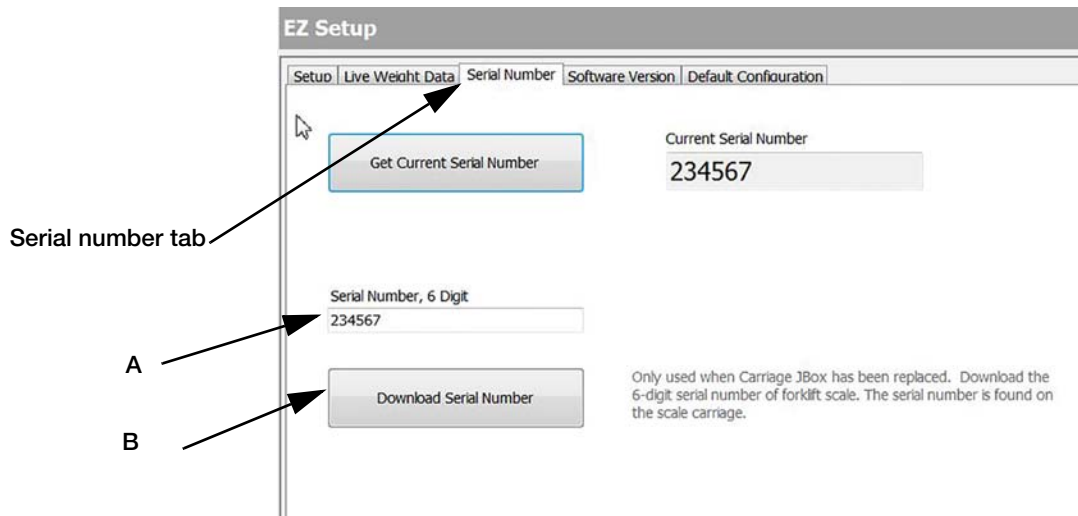

Figure 7-5. Serial Number Setup Screen

3. Once the serial number is download, a message *Serial Number sent to device* is displayed on the screen. Press OK to accept that number.



Note *The serial number of the scale is located on the right side of the carriage and also under the black cover plate on the scale assembly.*

The serial number (a six-digit entry) screen typically displays 0 or the last serial number downloaded.

The upload and download of each configuration file is no longer required. The iQube2 junction box has default factory settings to communicate with the CLS forklift scale.

7.3 iQube2 PCB Board Assembly Replacement

1. Remove j-box from the scale carriage. See Section 7.0 on page 42.
2. Disconnect load cell and coiled cable connectors
3. Loosen four screws to remove front cover of j-box.
4. Disconnect JST connectors for load cells and coiled cable.
5. Remove PCB board assembly.
6. Install new PCB board assembly and install screws using blue Loctite®.
7. Connect coiled cable JST connector to J1.
8. Connect left load cell cable JST connector to J2.
9. Connect right load cell cable JST connector to J3.
10. Replace cover and secure with four screws, Loctite not required.

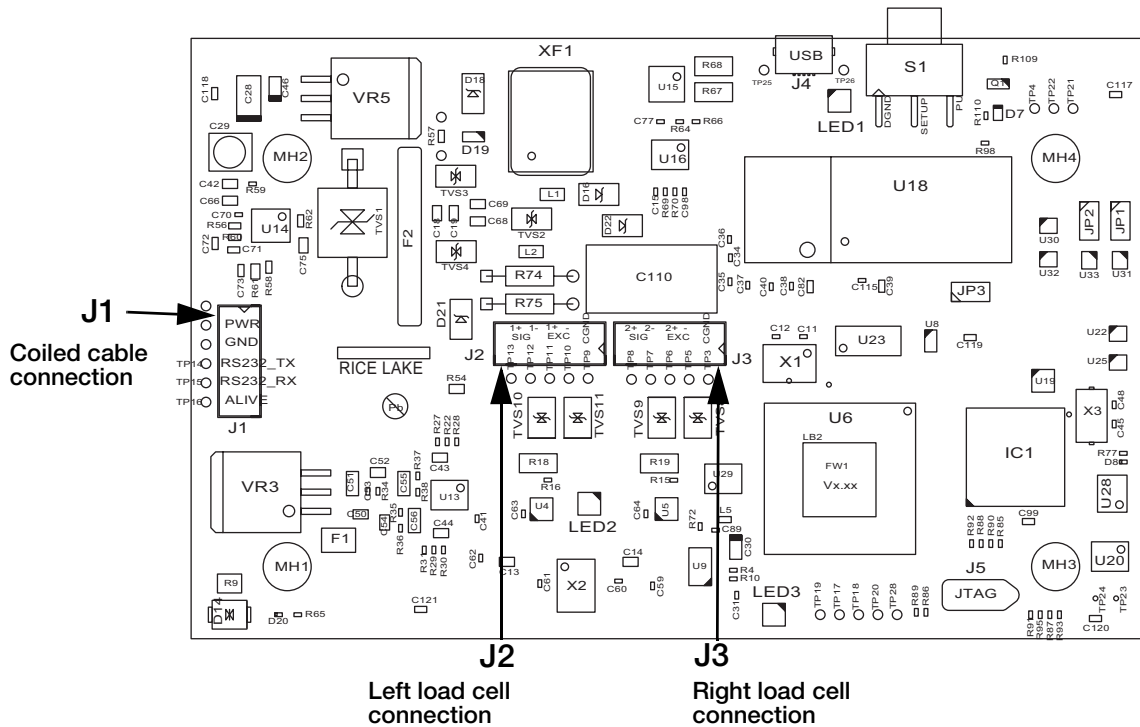



Figure 7-6. PCB Board Assembly

7.4 iQube 2.3 Cross References

When identifying the correct j-box cross referenced part number, please provide the serial number of the scale so that the Rice Lake Weighing Systems sales and service departments can track it to the correct top level part number sold.

To verify the correct j-box has been received, use Table 7-2, the iQube 2.3 j-box part number reference table.

The kit part number includes the appropriate load cell and cable adapters required to upgrade your unit.

 **Note** This manual references the part numbers 156294 only.

| 28" Forklift Carriage | | | |
|------------------------|---------------|-----------------------|--------------------|
| Top Level Fork Lift PN | Indicator | iQube 2.3 Kit PN | iQube 2.3 J-Box PN |
| 111033 | 420 Wired | 167345 | 167344 |
| 111034 | 420 Wireless | | 167416, 167344 |
| 111035 | 920i Wired | Upgrade not available | 121014 |
| 111036 | 920i Wireless | | 121014 |
| 34" Forklift Carriage | | | |
| Top Level Fork Lift PN | Indicator | iQube 2.3 Kit PN | iQube 2.3 J-Box PN |
| 96339 | 420 Wired | 167345 | 167344 |
| 96340 | 420 Wireless | | 167344 |
| 96341 | 920i Wired | Upgrade not available | 121014 |
| 96342 | 920i Wireless | | 121014 |
| 130822 | 420 Wired | 167356 | 167261 |
| 130823 | 420 Wireless | | 167261 |
| 130824 | 920i Wired | Upgrade not available | 130826 |
| 130825 | 920i Wireless | | 130826 |
| SPX or SO WO | 420 ABF | 167345 | 167344 |
| 120911 | 420 ABF | 167356 | 167261 |
| 161964 | 420 ABF | 167341 | 167261 |
| 125277 | CLS-M | 167340 | 164071 |
| 153539 | CLS-M | 167340 | 164071 |
| 151803 | CLS-420 | 167356 | 167261 |
| 132414 | CLS-M2 | 167340 | 164071 |
| → 156294 | CLS-M3 | 167340 | 164071 |
| 164649 | CLS-420 | 167341 | 167261 |
| 162279 | CLS-420 | 167341 | 167261 |
| 38" Forklift Carriage | | | |
| Top Level Fork Lift PN | Indicator | iQube 2.3 Kit PN | iQube 2.3 J-Box PN |
| 111038 | 420 Wired | | 167407 |
| 111039 | 420 Wireless | | 167407 |
| 111040 | 920i Wired | Upgrade not available | 121366 |
| 111041 | 920i Wireless | | 121366 |
| 151506 | 420 Wireless | | 167407 |
| 151490 | 920i Wireless | Upgrade not available | 121366 |

Table 7-2. iQube 2.3 Cross References

8.0 Appendix

8.1 Parts Breakout

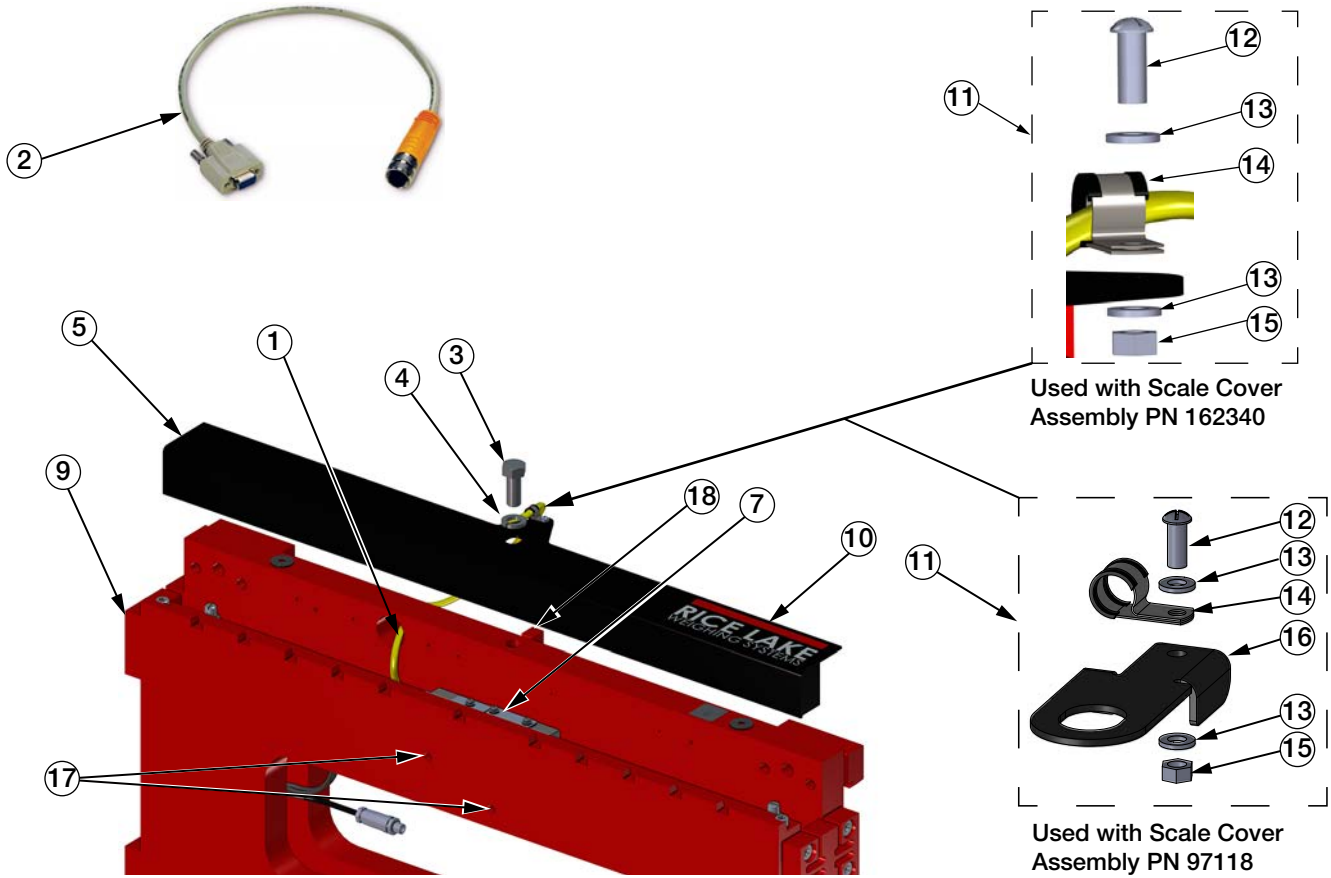
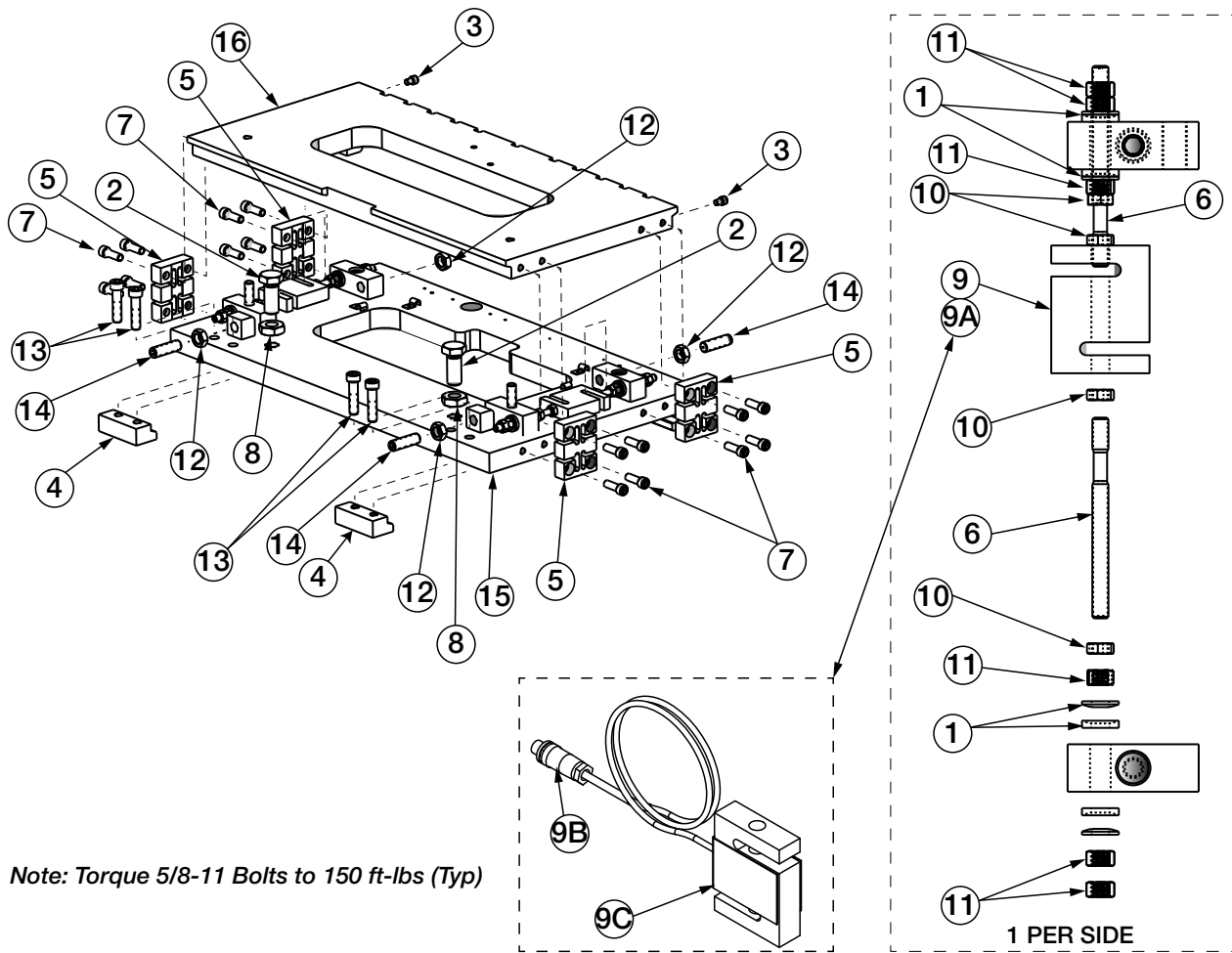

Figure 8-1. CLS-M3 Scale Assembly

| Item No. | Part No. | Item Description | Qty |
|----------|----------|--|-----|
| | 156294 | Scale, CLS-M3 | Ref |
| 1 | 125395 | Cable Assy, Coiled 5x18AWG | 1 |
| 2 | 153296 | Adapter | 1 |
| 3 | 127009 | Screw, Cap 5/8-11NC | 1 |
| 4 | 111731 | Washer, Lock 5/8 Regular | 1 |
| 5 | 162340 | Scale Cover Assembly with Decal (2015+) | 1 |
| | 97118 | Scale Cover Assembly | 1 |
| 7 | 164071 | iQube2 J-Box Assembly with Turk Connectors | 1 |
| 9 | 125368 | Scale, Cargo Lift (See Fig 8-2) | 1 |
| 10 | 99191 | Decal, Rice Lake | 1 |
| 11 | 167250 | Kit, Loop Clamp, Coiled Cable Assy (Inc 12-15) | 1 |
| | 150720 | Kit, Loop Clamp, Coiled Cable Assy (Inc 12-16) | 1 |
| 12 | 126980 | Screw Machine 10-32 x 1/2 | 1 |
| 13 | 15141 | Washer, Plain STD No 10 | 2 |
| 14 | 150719 | Clamp, Loop One Hole 1/4" | 1 |
| 15 | 14633 | Nut, Lock 10-32NF Hex | 1 |
| 16 | 130928 | Bracket, CLS (inc with PN 150720 only) | 1 |
| 17 | 125649 | Hex Socket Cap Screw 10-32 x 1 SST | 2 |
| 18 | 92831 | Centering Pin | 1 |



Note: Torque 5/8-11 Bolts to 150 ft-lbs (Typ)

Figure 8-2. CLS-M3 Scale Parts

| Item No. | Part No. | Item Description | Qty |
|----------|----------|---|-----|
| | 125368 | Scale Section Assy 34 | |
| 1 | 15198 | Washer, Spherical.53x1.12 | 8 |
| 2 | 92822 | Bolt, 1-8NCx2-3/8 Gr 5 | 2 |
| 3 | 92812 | Screw, Cap 3/8-16NCx1/2 | 2 |
| 4 | 126770 | Cleat, Bottom, Thick for use on worn carriages | 2 |
| 5 | 92828 | Flexure, 1x3x4.12 17-4PH | 4 |
| 6 | 92827 | Flexure Rod, 1/2-20x6.13 | 4 |
| 7 | 15061 | Screw, Cap 1/2-13NCx1-1/2 | 16 |
| 8 | 14701 | Nut, Jam 1-8NC HEX Steel | 2 |
| 9 | 125543 | Load Cell, With Quick Connect | 2 |
| 9A | 166623 | Load Cell, with Turk Screw Connectors (inc 9B & 9C) | 2 |
| 9B | 166756 | Conn,M12 5 Pin Male Field | 1 |
| 9C | 96198 | Load Cell,SBM RL20000 FLS | 1 |
| 10 | 14665 | Nut, Jam 1/2-20NF HEX SST | 8 |
| 11 | 109958 | Nut, Full 1/2-20NF HEX SST | 12 |
| 12 | 14688 | Nut, Jam 3/4-16NF HEX SST | 4 |
| 13 | 92810 | Screw, Cap 5/8-11NCx2-1/2 | 4 |
| 14 | 92814 | Screw, Set 3/4-16NFx2.406 | 4 |
| 15 | 125367 | WLDT, Assy Back Plate 34in | 1 |
| 16 | 125547 | WLDT, Front Plate 34in | 1 |

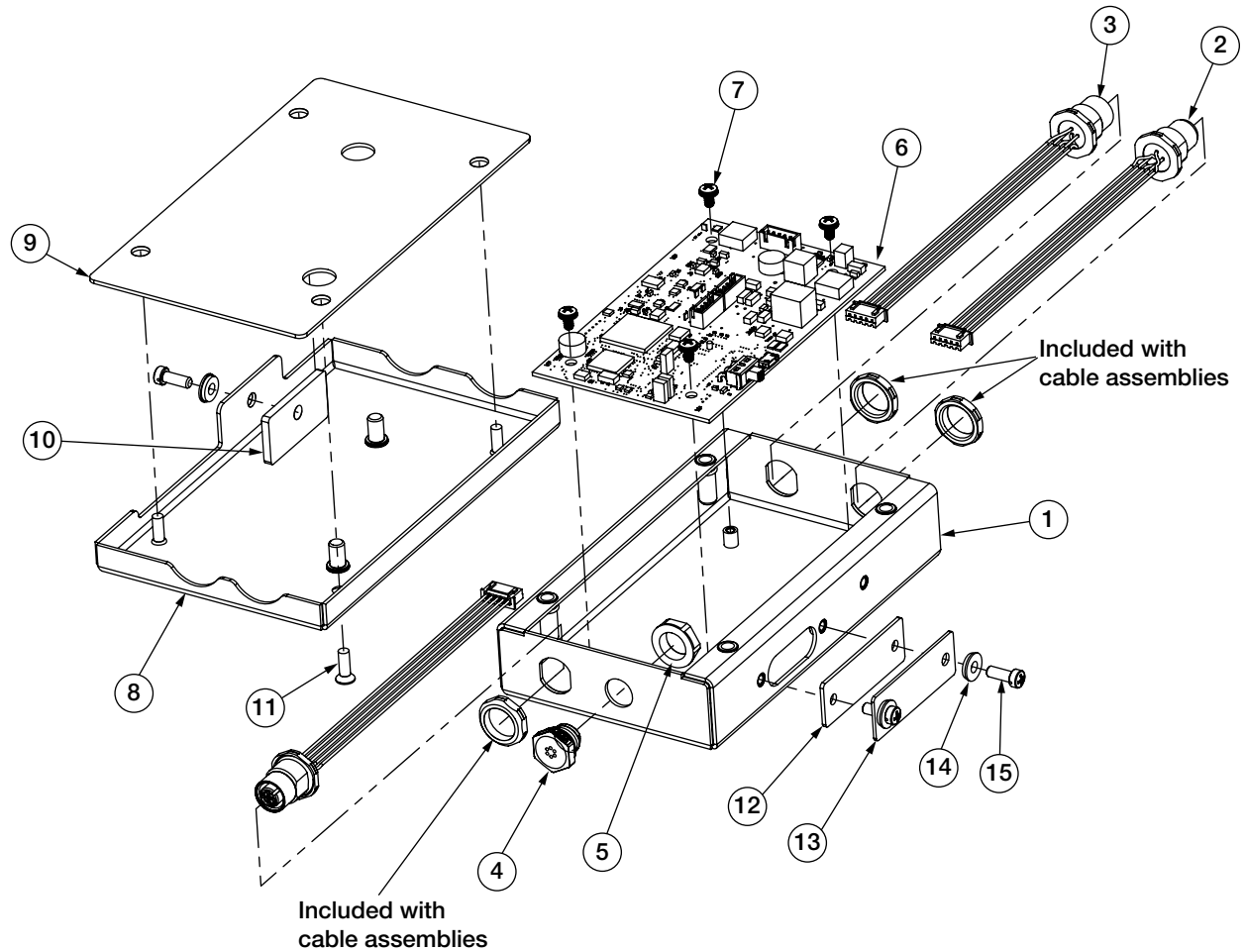

Figure 8-3. iQube2 J-Box Assembly, PN 164071

| Item No. | Part No. | Item Description | Qty. |
|----------|----------|-------------------------------------|------|
| 1 | 162378 | Enclosure Assembly | 1 |
| 2 | 163767 | Data Receptacle Cable Assembly | 1 |
| 3 | 163766 | Load Cell Cable Receptacle Assembly | 2 |
| 4 | 164598 | Breather Vent | 1 |
| 5 | 88734 | Nut, Breather Vent Thread | 1 |
| 6 | 167999 | J-Box PCB Assembly | 1 |
| 7 | 14839 | Screw, 6-32NC x 1/4 | 4 |
| 8 | 162383 | Cover Assembly | 1 |
| 9 | 163764 | Gasket, Assembly Cover | 1 |
| 10 | 164070 | Gasket, Access Cover | 1 |
| 11 | 100968 | CR-FHMS 0.164-32 x 0.5 x 0.5-N-SST | 4 |
| 12 | 163765 | Gasket, Access Cover | 1 |
| 13 | 162384 | Cover Plate, Access Hole | 1 |
| 14 | 75062 | Sealing Washer, #8 | 3 |
| 15 | 30623 | Screw, 8-32NC x 7/16 | 3 |
| 16 | 52342 | Label | 1 |

**THIS PAGE
FOR
REFERENCE
ONLY**

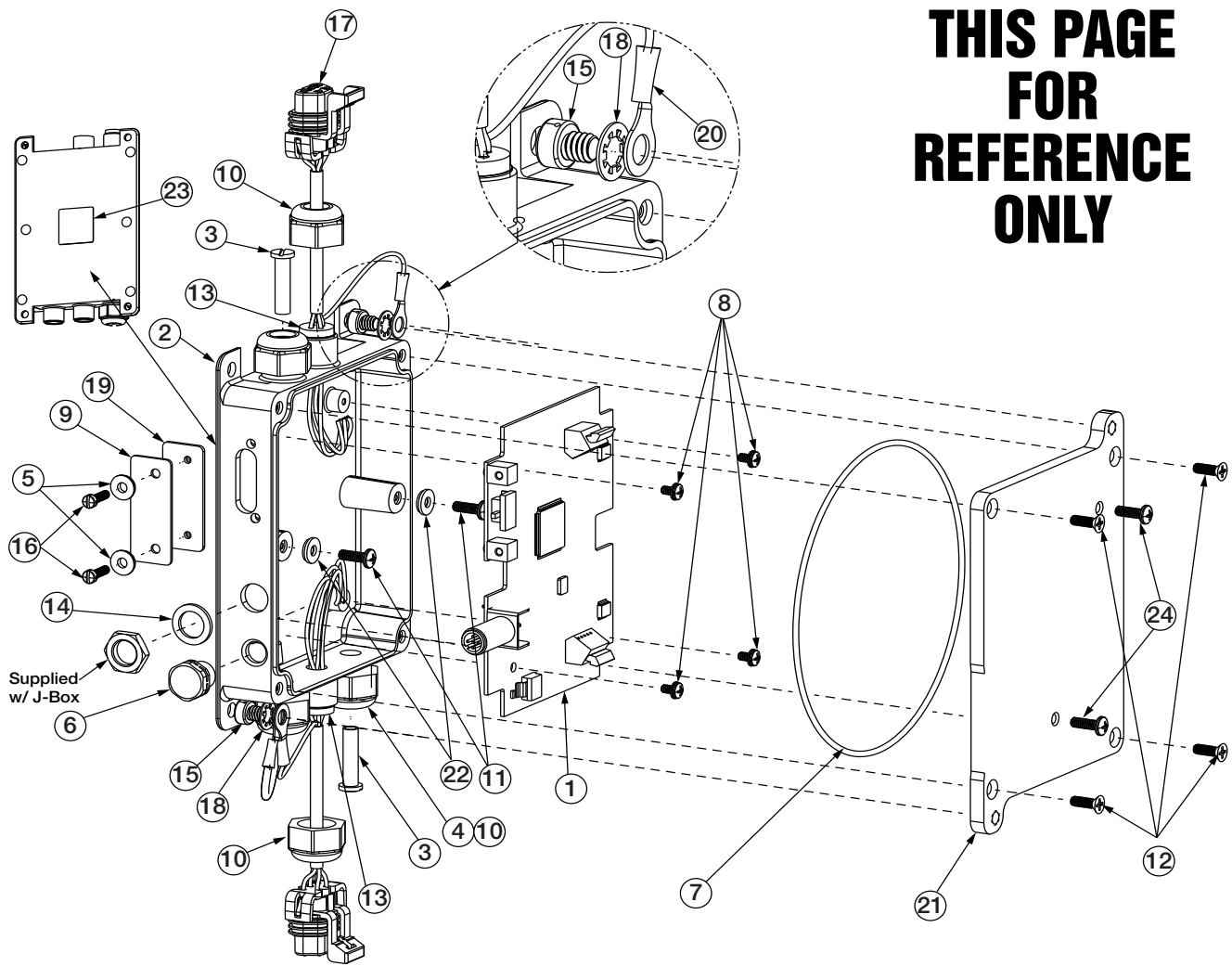

Figure 8-4. J-Box Assembly, PN 159589

| Item No | Part No. | Item Description | Qty |
|---------|----------|----------------------------|-----|
| 1 | 132726 | Board,CLS-M J-Box Rev C | 1 |
| 2 | 125640 | Enclosure,Machined CLS-M | 1 |
| 3 | 19528 | Post Only,Slotted Black | 2 |
| 4 | | Seal, Cable Gland | Ref |
| 5 | 75062 | Washer, Bonded Sealing SST | 2 |
| 6 | 128022 | Vent,Breather Sealed | 1 |
| 7 | 125650 | O-Ring,Buna N 70 160 | 1 |
| 8 | 14839 | Screw | Ref |
| 9 | 125564 | Cover, J-Box Set-Up Switch | 1 |
| 10 | | Cable Gland | Ref |
| 11 | | Screw | Ref |
| 12 | 100968 | Screw, Mach 8-32NC x 1/2 | 4 |
| 13 | 125376 | Seal, Cable Gland | 2 |

| Item No | Part No. | Item Description | Qty |
|---------|----------|---------------------------|-----|
| 14 | 125942 | Gasket,Rubber CLS-M | 2 |
| 15 | 42640 | Screw,Mach 1/4-28NF X 1/4 | 2 |
| 16 | 81220 | Screw, Mach 6-32NCx1/2 | 2 |
| 17 | 125559 | Cable Assy,CLS-M Carriage | 2 |
| 18 | 31546 | Washer,Lock 1/4 Internal | 2 |
| 19 | 125565 | Gasket, Access Port Cover | 1 |
| 20 | 126167 | Wire,Ground 4 Inch | 1 |
| 21 | 125494 | Plate,Adapter CLS-M | 1 |
| 22 | | Washer | Ref |
| 23 | 52342 | Label | 1 |
| 24 | 125649 | Screw, Cap 10-32 x 1 SST | 2 |

8.2 Troubleshooting Table

| Symptom | Possible Cause | Action |
|---|---|--|
| Scale displaying negative weight | Forks are resting (even slightly) on the floor. | Lift forks up off floor. |
| Scale reading high against test weight. | Material, like wood debris, between the scale and the forklift carriage. | Remove debris. |
| | Material, like wood debris, between the front and back scale plates. | Remove debris. |
| | Centering pin touching the forklift carriage, causing it to teeter back and forth. | Adjust scale carriage, centering pin should not touch on sides and bottom. |
| | Bottom cleats not adjusted properly or loose. | Adjust to proper gap using jam nuts, 0.02" |
| | If all these steps do not resolve your issue, check the following, | |
| | J-box error | Open j-box and look for obvious damage |
| | Load cell errors | Test mV/v levels, at 1.5 mV per 1,000 lb, test at 350 ohms |
| | Calibration is required | Calibrate the scale using Revolution™ |
| Scale reading low against test weight. | Zero key has been pressed with a negative weight reading, while forks are on the floor. | Lift forks off ground, press the Zero key |
| | Material, like wood debris, between the scale and the forklift carriage. | Remove debris |
| | Material, like wood debris, between the front and back scale plates. | Remove debris |
| | Centering pin touching the forklift carriage, causing it to teeter back and forth. | Adjust scale carriage, centering pin should not touch on sides and bottom. |
| | Bottom cleats not adjusted properly or loose. | Adjust to proper gap using jam nuts, 0.02" |
| | If all these steps do not resolve your issue, check the following | |
| | J-box error | Open j-box and look for obvious damage. |
| | Load cell errors | Test mV/v levels, at 1.5 mV per 1,000 lb, test at 350 ohms |
| Calibration is required | Calibrate the scale using Revolution. | |
| Scale not returning to zero (0) | Forks are touching the ground. | Lift forks off ground, press the Zero key. |
| | Material, like wood debris, between the scale and the forklift carriage. | Remove debris |
| | Material, like wood debris, between the front and back scale plates. | Remove debris |
| | Centering pin touching the forklift carriage, causing it to teeter back and forth. | Adjust scale carriage, centering pin should not touch on sides and bottom. |
| | Bottom cleats not adjusted properly or loose. | Adjust to proper gap using jam nuts, 0.02" |
| | Scale is in motion, it won't zero if the forklift is moving: <ul style="list-style-type: none"> • Forks moving up and down • Forklift is being driven | Bring forklift to a complete stop and ensure forks are still. |
| | If all these steps do not resolve your issue, check the following, | |
| | J-box error | Open j-box and look for obvious damage. |
| Load cell errors | Test mV/v levels, at 1.5 mV per 1,000 lb, test at 350 ohms. | |
| Will not display small weight values | Digital filter sensitivity is too high. | Using Revolution: scales menu/scales #1/filtering change the digital filtering sensitivity to light and change digital filter threshold to 10°. |
| Unstable weight | Power connections faulty, low battery | Check battery power cable. Check for low battery voltage. |
| Scale reading incorrect weight value | Tare is enabled | At stable zero weight, press the TARE key to return to normal weighing mode. |

| Symptom | Possible Cause | Action | |
|--|--|---|---------------|
| Intermittent weight readings, weight reading high and low. | Material, like wood debris, between the scale and the forklift carriage. | Remove debris | |
| | Material, like wood debris, between the front and back scale plates. | Remove debris | |
| | Centering pin touching the forklift carriage, causing it to teeter back and forth. | Adjust scale carriage, centering pin should not touch on sides and bottom. | |
| | Bottom cleats not adjusted properly. | Adjust to proper gap using jam nuts, 0.02" | |
| | Check alignment of load cells. | Adjust load cells. | |
| | Low forklift battery | Charge forklift battery, disconnect power prior to charging. | |
| | Check coiled cable for loose connections & wear. | Fasten coiled cable connections. Replace coiled cable, if damaged. | |
| | If all these steps do not resolve your issue, check the following, | | |
| | Load cell connections on j-box | Securely fasten connections. | |
| | J-box error | Open j-box and look for obvious damage. | |
| | Load cell errors | Test mV/v levels, at 1.5 mV per 1,000 lb, test ohms using Revolution/Live Weight Data/Cell 1 & 2 MV | |
| | Calibration is required. | Calibrate the scale using Revolution. | |
| | Weight on forks, no displayed weight. | Material, like wood debris, between the scale and the forklift carriage. | Remove debris |
| Material, like wood debris, between the front and back scale plates. | | Remove debris | |
| Centering pin touching the forklift carriage, causing it to teeter back and forth. | | Adjust scale carriage, centering pin should not touch on sides and bottom. | |
| Bottom cleats not adjusted properly. | | Adjust to proper gap using jam nuts, 0.02" | |
| Low forklift battery. | | Charge forklift battery. | |
| Coiled cable error | | Check coiled cable connections wand wear and tear. | |
| If all these steps do not resolve your issue, check the following, | | | |
| J-box sealing switch is in calibration mode. | | Move switch to weighing mode. | |
| Load cell connections on j-box loose. | | Securely fasten connections. | |
| J-box error | | Open j-box and look for obvious damage. | |
| Load cell errors | | Test mV/v levels, at 1.5 mV per 1,000 lb, test ohms. | |
| Calibration is required. | | Calibrate the scale using Revolution. | |

| Symptom | Possible Cause | Action |
|---|--|--|
| VIRTUi2 displays INVALID. | Calibration switch in open position J-box error check wiring connections Check load cell wires Check excitation on j-box at 4.1. | Move calibration switch to closed position. Press reset in VIRTUi2. Correct wiring. Change j-box. |
| VIRTUi2 weight display is blank. | No power. | Turn on COMPOW Check |
| Scale carriage is not fitting securely on forklift during installation. | May have to use electric grinder to grind down the centering pin on the forklift scale or center slot on forklift. May have to grind or torch down the area where the top cleats of the forklift scale are mounted. May have to grind or torch side of forklift carriage due to previously installed side shift protection method. | Discuss with local terminal manager to determine if scale dealer is to perform this chargeable service. |
| Loose screws on j-box | | Apply loctite 242 or 243 for greasy environments, to screws and tighten. |

8.3 Troubleshooting iQube2 LEDs

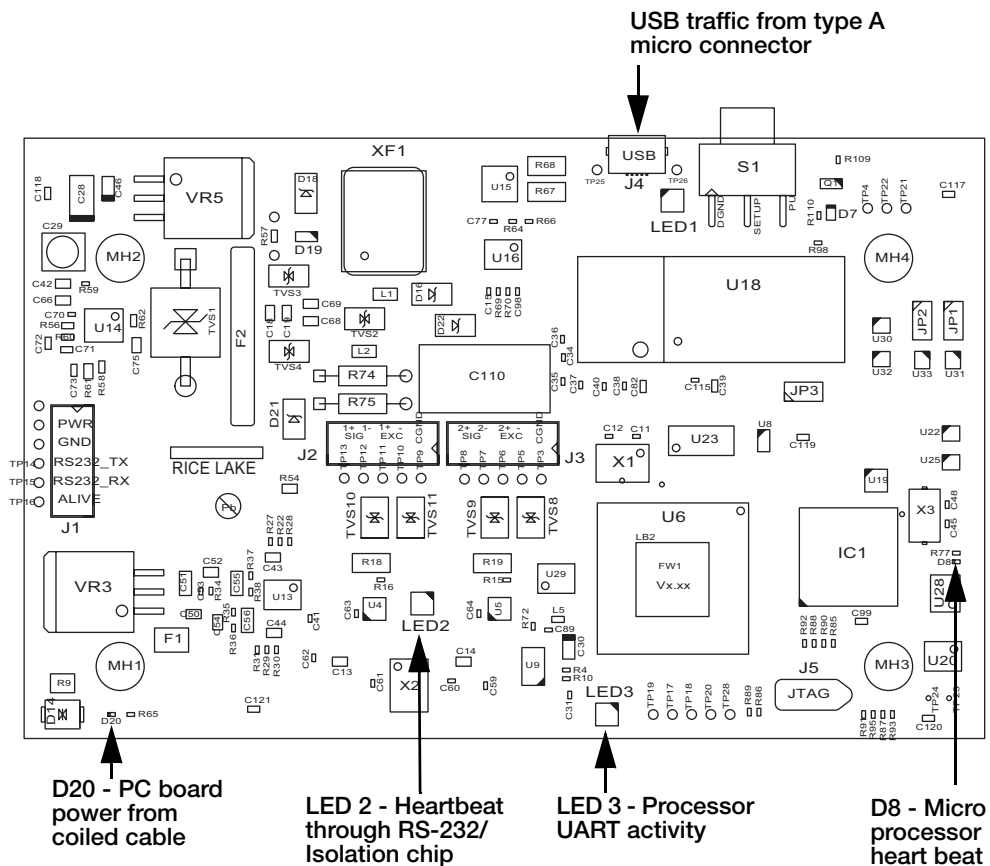

Figure 8-5. Troubleshooting iQube2 PCB Assembly LEDs (PN 162508)



© Rice Lake Weighing Systems Specifications subject to change without notice.
Rice Lake Weighing Systems is an ISO 9001 registered company.

230 W. Coleman St. • Rice Lake, WI 54868 • USA

U.S. 800-472-6703 • Canada/Mexico 800-321-6703 • International 715-234-9171 • Europe +31 (0)26 472 1319

www.ricelake.com www.ricelake.mx www.ricelake.eu www.ricelake.co.in