

Remote I/O

ALLEN-BRADLEY® Remote I/O Interface

for IQ plus® 310A and IQ plus® 800/810 Indicators

Version 2.04

Installation and Programming Manual



RICE LAKE WEIGHING SYSTEMS

Industrial Solutions on a Global Scale®



Contents

About This Manual	1
1.0 Introduction.....	1
2.0 Installation	2
2.1 Physical Connections	2
2.1.1 Termination Resistance	3
2.1.2 Indicator Connections	3
2.1.3 A-B Network Connections.....	3
2.2 DIP Switch Configuration	4
2.3 LED Indicators	6
2.4 Indicator Setup	6
2.4.1 IQ plus 310A Configuration	6
2.4.2 IQ plus 800/810 Configuration.....	7
2.5 Allen-Bradley Serial Stream.....	7
2.6 Decimal Point Handling.....	7
2.7 Installing the 20 mA Current Loop Option	8
3.0 Discrete Transfer Commands	9
3.1 Output Image Table Format	9
3.2 Input Image Table Format	14
4.0 Block Transfer Commands.....	16
4.1 Set Tare Value	17
4.2 Set Setpoint Values	18
4.3 Read Setpoint Values	21
4.4 Read Accumulator Value	22
4.5 Read Channel Peak Value	23
4.6 Read Rate of Change Value.....	24
4.7 Read Tare Value	25
4.8 Read Gross Value.....	26
4.9 Read Net Value	27
4.10 Read Multiple Weights	28
4.11 Set Multiple Setpoint Values.....	30
4.12 Read Multiple Setpoint Values.....	32
4.13 Set Batching State	34
5.0 Operation.....	35
5.1 Test Program for Verifying Remote I/O Interface Operation	35
5.2 PLC Program for Converting 20-bit Values to Floating Integers.....	37
5.3 Using Block Transfer to Set and Read Setpoint Values	38
5.4 Acquiring a Tare Value	40
5.5 Reading Weights from Multiple Scale Channels	41
6.0 Troubleshooting	42
7.0 Power Supply Board	44
7.1 Fuse Replacement.....	44
7.2 Operating Voltage Conversion	45
8.0 Remote I/O Interface Specifications	46
Remote I/O Interface Limited Warranty	47

DISCONTINUED

About This Manual

This manual provides information needed to install and use the Rice Lake Weighing Systems Remote I/O Interface. The Remote I/O Interface allows IQ plus® 310A, IQ plus 800, and IQ plus 810 indicators to communicate with PLC® and SLC™ controllers using the Allen-Bradley® Remote I/O network.¹

The Remote I/O Interface is housed in a NEMA 4X stainless steel enclosure to permit use in washdown environments. RS-232 communications is standard; a 20 mA current loop interface option is available for connection to IQ plus 800/810 indicators.

1. Allen-Bradley®, PLC®, and SLC™ are trademarks of Allen-Bradley Company, Inc., a Rockwell International company.

This manual applies to the following software versions:

- Remote I/O Interface, Version 2.04
- IQ plus 800/810, Version 3.1
- IQ plus 310A, Version 5.0

Warning *Some procedures described in this manual require work inside the Remote I/O enclosure. These procedures are to be performed by qualified service personnel only.*



Authorized distributors and their employees can view or download this manual from the Rice Lake Weighing Systems distributor site at www.rlws.com.

1.0 Introduction

The Remote I/O Interface returns weight and status information streamed from the IQ plus 310A or IQ plus 800/810 indicators to the PLC controller. The Remote I/O Interface provides full control of indicator functions to the PLC programmer. Indicator configuration and calibration must be done at the indicator front panel.

The following figure shows an example of the Remote I/O Interface used to connect an IQ plus 810 indicator to a PLC or SLC controller on an Allen-Bradley Remote I/O network.

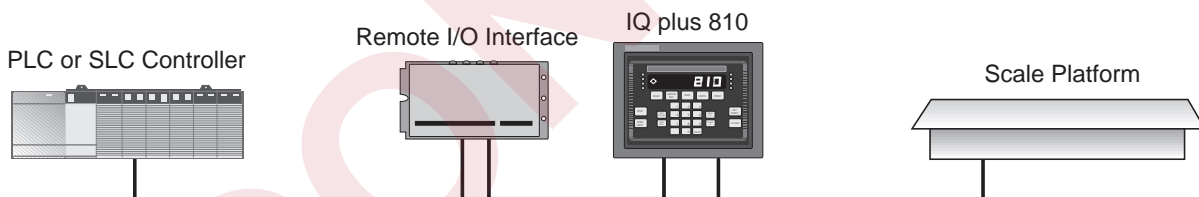

The Remote I/O Interface behaves as a node adapter device to the master PLC, appearing as a quarter rack of I/O. The PLC controller and Remote I/O Interface communicate using a quarter rack of data slots (4 slots with 8 bits of input, 8 bits of output per slot).

The PLC controller sends commands to the indicator through the Remote I/O Interface by writing the commands to the output image table, then reads weight and status data returned through the Remote I/O Interface in the input image table. These actions are referred to as discrete reads and discrete writes. See Section 3.0 on page 9 for information about using discrete transfer commands.

Weight Data Formats

Depending on the expected magnitude and required precision of the weight data returned from the indicator, the PLC controller can request weight data in various formats. The discrete write command can specify weight data be returned to the input image table using either 16-bit signed or 20-bit unsigned values.

Weight data formats supported by the Remote I/O Interface allow values of -16,777,215 through +16,777,215 to be returned to the PLC controller using discrete transfer commands. The maximum displayable value for the supported indicators is 9,999,999.

2.0 Installation

The Remote I/O Interface is designed to be mounted on a wall or other vertical surface, with the four status LEDs on top and the cable connections at the bottom. Before mounting the unit, attach the communications cables, select the termination resistance, and set the configuration DIP switches as described in the following sections.

2.1 Physical Connections

Initial setup and configuration of the Remote I/O Interface requires opening the Interface enclosure. The enclosure cover uses 16 screws to ensure proper seating of the cover gasket. Use the torquing pattern shown in Figure 2-1 to prevent deformation of the gasket when removing and replacing the cover. Torque screws to 15 in-lb when replacing the cover.

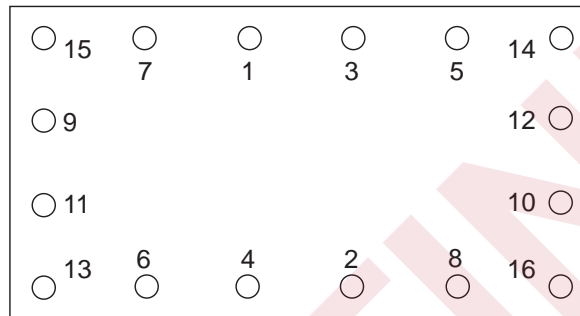

Figure 2-1. Torquing Pattern for Remote I/O Interface Enclosure

Figure 2-2 shows the layout of the Remote I/O Interface logic board. The following sections describe DIP switch configuration and cable connections to the PLC and indicator.

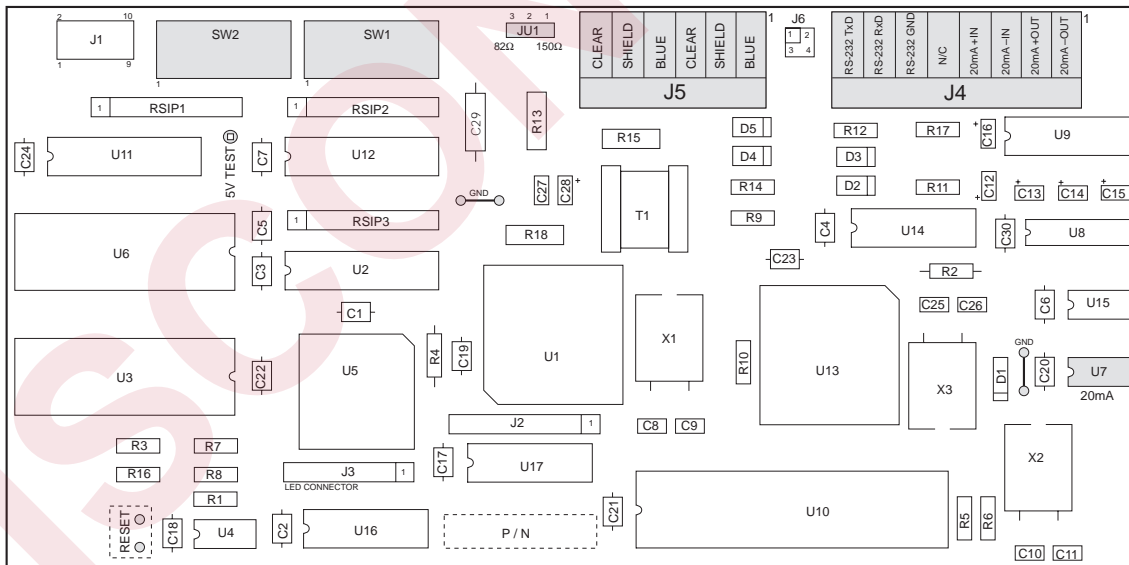

Figure 2-2. Remote I/O Interface Logic Board Layout

2.1.1 Termination Resistance

If the Remote I/O Interface is the last, or only, device attached to the PLC, the interface must provide a termination resistance.

Use Table 2-1 to determine the appropriate termination resistance value and JU1 jumper position for the network. If the Remote I/O Interface is not the last device in a chain, position the jumper on one pin only. Resistance values for the jumper positions are marked on the Remote I/O Interface logic board.

Network Data Rate	Maximum Cable Length	Maximum Nodes	Termination Resistance	JU1 Jumper Position
57.6 Kbps	10 000 ft	16	150W	1-2
115.2 Kbps	5000 ft			
230.4 Kbps	2500 ft	32	82W	2-3

Table 2-1. JU1 Jumper Positions and Termination Resistance Values

2.1.2 Indicator Connections

Connections to the indicator are made at connector J4 on the Remote I/O Interface controller board (see Figure 2-2 on page 2 for board location of J4). Figure 2-3 shows the J4 connector layout for the Remote I/O Interface. Table 2-2 shows connections between the Remote I/O Interface and the indicators for RS-232 and 20 mA current loop communications.



Figure 2-3. J4 Indicator Connections

Remote I/O Interface J4 Connections			IQ plus 800/810 Connections to J7	IQ plus 310A Connections to J4	Indicator Connections	
20 mA	-OUT	1	8	N/C	-IN	20mA
	+OUT	2	7		+IN	
	-IN	3	10		-OUT	
	+IN	4	12		+OUT	
RS-232	GND	6	12	2	GND	RS-232
	RxD	7	11	1	TxD	
	TxD	8	9	3	RxD	

Table 2-2. J4 Connections to Indicators for RS-232 and 20 mA Communications

NOTE: The 20 mA current loop interface connection requires that the 20 mA option be installed in both the Remote I/O Interface and the IQ plus 800/810. See Section 2.7 on page 8 for information about installing the 20 mA option.

2.1.3 A-B Network Connections

Connections to the Allen-Bradley network are made at connector J5 on the Remote I/O Interface controller board (see Figure 2-2 on page 2 for board location of J5). Figure 2-4 shows the connector layout for network connections. Connectors 4-6 are tied to connectors 1-3 to allow daisy-chaining through the Remote I/O Interface.

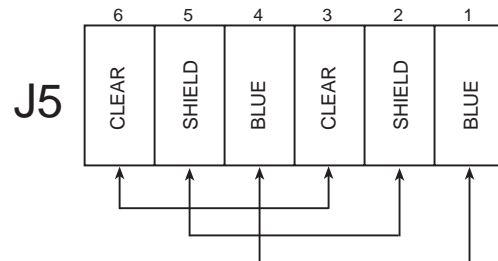

Figure 2-4. J5 Network Connections

2.2 DIP Switch Configuration

Two banks of DIP switches, SW1 and SW2, are used to configure the Remote I/O Interface for communication with the indicator and the network. Figure 2-5 shows the switch assignments for SW1 and SW2.

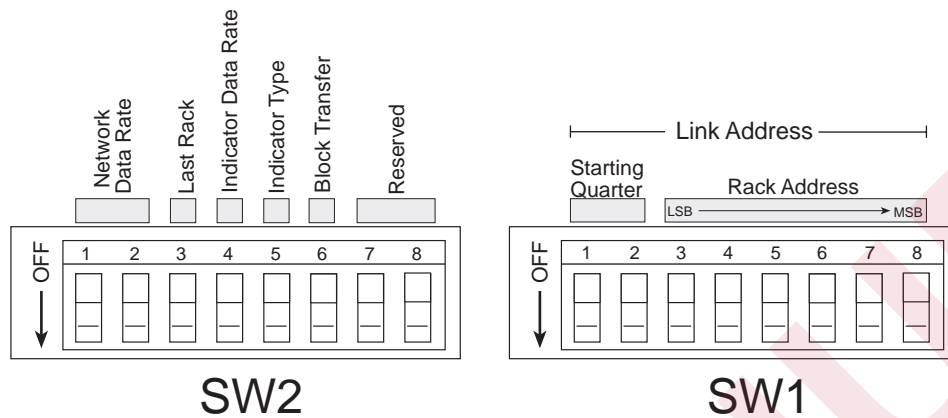

Figure 2-5. SW1 and SW2 DIP Switch Assignments

Network Data Rate

SW2-1 and SW2-2 set the data rate of the Allen-Bradley network. Use Table 2-3 to select the correct switch settings for the network.

Remote I/O Data Rate	SW2 Switch Settings	
	1	2
57.6 Kbps	ON	ON
115.2 Kbps	OFF	ON
230.4 Kbps	ON	OFF
	OFF	OFF

Table 2-3. Network Data Rate

Last Rack

Set SW2-3 ON if the Remote I/O Interface link address includes the highest module group in this rack address.

Indicator Data Rate

SW2-4 sets the data rate used to communicate with the attached indicator. Set this switch OFF for 9600 bps, ON for 19.2 Kbps.

Indicator Type

SW2-5 sets whether the attached indicator is an IQ plus 800/810 (switch OFF) or an IQ plus 310A (switch ON).

Block Transfer

Set SW2-6 ON to enable or OFF to disable block transfer to the Remote I/O Interface. Setting this switch OFF causes the Remote I/O Interface to ignore unsolicited block transfer requests from the PLC.

NOTE: Switches SW2-7 and SW2-8 should be set OFF. If the Remote I/O Interface returns incrementing values rather than weights to the PLC controller, verify that SW2-8 is set OFF.

Starting Quarter

Switches SW1-1 and SW1-2 set the starting quarter (or group number) used by the Remote I/O Interface. Use Table 2-4 to select the correct switch settings.

Starting Quarter	Group Number	SW1 Switch Settings	
		1	2
1st	0	ON	ON
2nd	2	OFF	ON
3rd	4	ON	OFF
4th	6	OFF	OFF

Table 2-4. Starting Quarter

Rack Address

Switches SW1-3 through SW1-8 are used to set the rack address of the Remote I/O Interface. Use Table 2-5 on page 5 to select the correct switch settings for the rack address. Note that setting a switch OFF acts as a logical “1” and that SW1-3 represents the least significant bit (LSB) of the rack address.

Rack Address		SW1 Switch Settings						Rack Address		SW1 Switch Settings					
Decimal	Octal	3	4	5	6	7	8	Decimal	Octal	3	4	5	6	7	8
00	00	ON	ON	ON	ON	ON	ON	32	40	ON	ON	ON	ON	ON	OFF
01	01	OFF	ON	ON	ON	ON	ON	33	41	OFF	ON	ON	ON	ON	OFF
02	02	ON	OFF	ON	ON	ON	ON	34	42	ON	OFF	ON	ON	ON	OFF
03	03	OFF	OFF	ON	ON	ON	ON	35	43	OFF	OFF	ON	ON	ON	OFF
04	04	ON	ON	OFF	ON	ON	ON	36	44	ON	ON	OFF	ON	ON	OFF
05	05	OFF	ON	OFF	ON	ON	ON	37	45	OFF	ON	OFF	ON	ON	OFF
06	06	ON	OFF	OFF	ON	ON	ON	38	46	ON	OFF	OFF	ON	ON	OFF
07	07	OFF	OFF	OFF	ON	ON	ON	39	47	OFF	OFF	OFF	ON	ON	OFF
08	10	ON	ON	ON	OFF	ON	ON	40	50	ON	ON	ON	OFF	ON	OFF
09	11	OFF	ON	ON	OFF	ON	ON	41	51	OFF	ON	ON	OFF	ON	OFF
10	12	ON	OFF	ON	OFF	ON	ON	42	52	ON	OFF	ON	OFF	ON	OFF
11	13	OFF	OFF	ON	OFF	ON	ON	43	53	OFF	OFF	ON	OFF	ON	OFF
12	14	ON	ON	OFF	OFF	ON	ON	44	54	ON	ON	OFF	OFF	ON	OFF
13	15	OFF	ON	OFF	OFF	ON	ON	45	55	OFF	ON	OFF	OFF	ON	OFF
14	16	ON	OFF	OFF	OFF	ON	ON	46	56	ON	OFF	OFF	OFF	ON	OFF
15	17	Reserved						47	57	OFF	OFF	OFF	OFF	ON	OFF
16	20	ON	ON	ON	ON	OFF	ON	48	60	ON	ON	ON	ON	OFF	OFF
17	21	OFF	ON	ON	ON	OFF	ON	49	61	OFF	ON	ON	ON	OFF	OFF
18	22	ON	OFF	ON	ON	OFF	ON	50	62	ON	OFF	ON	ON	OFF	OFF
19	23	OFF	OFF	ON	ON	OFF	ON	51	63	OFF	OFF	ON	ON	OFF	OFF
20	24	ON	ON	OFF	ON	OFF	ON	52	64	ON	ON	OFF	ON	OFF	OFF
21	25	OFF	ON	OFF	ON	OFF	ON	53	65	OFF	ON	OFF	ON	OFF	OFF
22	26	ON	OFF	OFF	ON	OFF	ON	54	66	ON	OFF	OFF	ON	OFF	OFF
23	27	OFF	OFF	OFF	ON	OFF	ON	55	67	OFF	OFF	OFF	ON	OFF	OFF
24	30	ON	ON	ON	OFF	OFF	ON	56	70	ON	ON	ON	OFF	OFF	OFF
25	31	OFF	ON	ON	OFF	OFF	ON	57	71	OFF	ON	ON	OFF	OFF	OFF
26	32	ON	OFF	ON	OFF	OFF	ON	58	72	ON	OFF	ON	OFF	OFF	OFF
27	33	OFF	OFF	ON	OFF	OFF	ON	59	73	OFF	OFF	ON	OFF	OFF	OFF
28	34	ON	ON	OFF	OFF	OFF	ON	60	74	ON	ON	OFF	OFF	OFF	OFF
29	35	OFF	ON	OFF	OFF	OFF	ON	61	75	OFF	ON	OFF	OFF	OFF	OFF
30	36	ON	OFF	OFF	OFF	OFF	ON	62	76	ON	OFF	OFF	OFF	OFF	OFF
31	37	OFF	OFF	OFF	OFF	OFF	ON	63	77	OFF	OFF	OFF	OFF	OFF	OFF

Table 2-5. SW1 Switch Settings for Remote I/O Interface Link Address

2.3 LED Indicators

Four LEDs on the top of the Remote I/O Interface enclosure provide status information for the operator. Table 2-6 summarizes the function of the LEDs. See Section 6.0 for more troubleshooting information.

LED	Color	Function	
Power	Green	On when external power applied; blinks if microprocessor is not executing	
RIO	Green	On steady when communicating with the PLC	
		Blinks if node adapter is receiving only RESET commands from PLC	Check if PLC is in program mode
		Off indicates no connection to the network	Check that baud rates configured for Remote I/O Interface and PLC match Check wiring at J5 connector
RxD	Red	Blinks with every character received from the indicator	May appear to be on steady when indicator is streaming data
TxD	Red	Blinks with every character sent to the indicator	

Table 2-6. Remote I/O Interface LED indicators

2.4 Indicator Setup

Indicators communicate with the Remote I/O Interface using the indicator EDP port. Both IQ plus 310A and IQ plus 800/810 indicators support RS-232 communications. The IQ plus 800/810 indicators can also use 20 mA current loop communications providing the 20 mA option is installed in both the indicator and the Remote I/O Interface.

2.4.1 IQ plus 310A Configuration

Table 2-7 shows the configuration parameters recommended for the IQ plus 310A indicator to communicate with the Remote I/O Interface. See the *IQ plus 310A Installation & Service Manual* for detailed information about configuring the indicator.

IQ plus 310A Configuration Settings			Notes
EDP	MODE	STREAM	Required
	BAUD	9600	Must match DIP switch selection on Remote I/O Interface
	BITS	8 NONE	Required
	TERMIN	CR	
	EOL DLY	0 MS	
	FORMAT	REMOTE	
	CASE	UPPER	
	RESPOND	STATUS	
PRINTER	MODE	TICKET	Specify TICKET mode to improve indicator performance
SETUP	KEYBRD	DISABLE	Select to disable front panel (blind operation)
	TARE RS	REGULT	Required
	TARE FN	AUTO	

Table 2-7. IQ plus 310A Configuration Settings

2.4.2 IQ plus 800/810 Configuration

Table 2-8 shows the configuration parameters recommended for the IQ plus 800/810 indicators to communicate with the Remote I/O Interface. See the *IQ plus 800/810 Installation Manual* for detailed information about configuring the indicator.

IQ plus 800/810 Configuration Settings				Notes
CONFIG	FEATURE	A/B	ON	A/B FEATURE is enabled at the factory for indicators ordered with the Remote I/O option. If the A/B FEATURE is OFF, call RLWS for information about activating the feature.
SERIAL	EDP	BAUD	9600 or 19200	Must match DIP switch selection on Remote I/O Interface
		BITS	8 NONE	Required
		TERMIN	CR	
		EOL DLY	0 MS	
	ABSTRM	EDP		
	STREAM	OFF		

Table 2-8. IQ plus 800/810 Configuration Settings

2.5 Allen-Bradley Serial Stream

Figure 2-6 shows the format of the Allen-Bradley serial stream format. This format is output from the indicator when the EDP port AB-RIO and STREAM parameters are set ON.

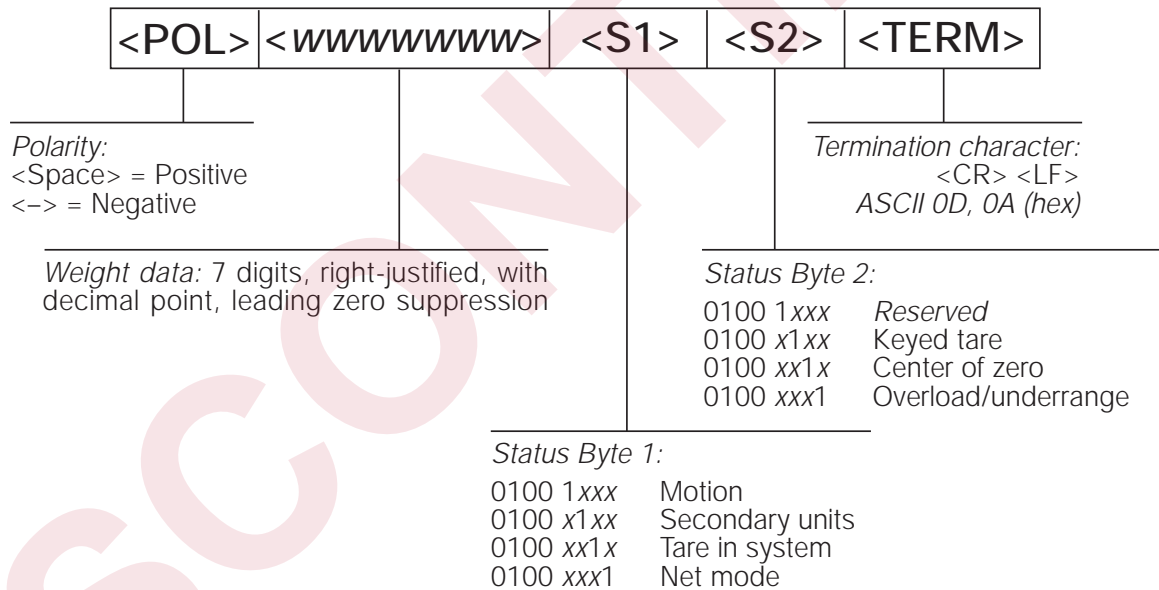

Figure 2-6. Allen-Bradley Serial Stream (ABSTRM) Format

2.6 Decimal Point Handling

Discrete Transfer

Discrete transfer commands return no decimal point information to the PLC. For example, a value of 750.1 displayed on the indicator is returned to the PLC as 7501.

Block Transfer

Block transfer commands support decimal point information with no special handling.

2.7 Installing the 20 mA Current Loop Option

The Remote I/O Interface can communicate with IQ plus 800/810 indicators using the 20 mA current loop interface if the option is installed in both the Interface and the indicator. Installing the 20 mA option disables RS-232 communications.

Use the following procedure to install the 20 mA option for the Remote I/O Interface:

1. Disconnect Remote I/O Interface from power source.
2. Remove enclosure cover.
3. Install 20 mA chip in socket U7 with notch toward inside of circuit board as shown in Figure 2-2 on page 2.
4. Make cable connections to pins 1–4 on connector J4 (see Section 2.1.2 on page 3).
5. Replace enclosure cover and tighten screws using torquing pattern shown in Figure 2-1.
6. Reconnect power to Remote I/O Interface.

3.0 Discrete Transfer Commands

The PLC controller uses discrete write and discrete read commands to send and receive data from the Remote I/O Interface. The PLC controller and Remote I/O Interface share a quarter rack of slot space, resulting in two 16-bit words for the output image table (used to write commands to the indicator) and two 16-bit words for the input image table (used to read data from the indicator).

3.1 Output Image Table Format

The PLC places two 16-bit words in the PLC output image table which are read by the Remote I/O Interface node adapter. A discrete write command is performed when the PLC controller writes data to the output image table. The Remote I/O Interface reads the contents of the output image table, translates the command to a form that can be used by the indicator, and sends the command to the indicator.

The format of the output image table is shown in Table 3-1.

Bit	15	14	13	12	11	10	9	8	7	6	5	4	3	2	1	0
Word 0	v15	v14	v13	v12	v11	v10	v09	v08	v07	v06	v05	v04	v03	v02	v01	v00
Word 1	R	s	s	s	w	R	R	R	c	c	c	c	c	c	c	c

Table 3-1. Output Image Table Format

where:

v00–v15	16-bit signed integer value
R	Reserved
sss	Status data format
w	Weight format
cccc cccc	Command number

These fields are described below:

Value

Word 0 of the output image table is used for passing value data on certain commands. This field should be used only when block transfer is disabled. For example, to enter a tare value, use word 0 to specify the tare value; the Enter Tare command number (44) is specified in bits 00 through 07 of word 1.

Values entered in this field are treated as 16-bit signed integers. Possible values range from –32,768 to 32,767.

Status Data Format

The status data format bits specify the format of status data returned to the PLC.

000	Remote function status data
001	Batch function status data (valid only for Command 42, Batch Status)
010–111	Not defined

Remote and batch function status data bits are described in Section 3.2.

Weight Format

Specifies the format of the weight data returned to the PLC controller:

0	16-bit signed integer (negative values are formatted as 2's complement)
1	20-bit unsigned integer

The 16-bit signed integer format should be used when the returned weight value is expected to be less than 32,767. This format allows the PLC controller to make a direct conversion of the value.

The 20-bit unsigned integer format is provided for large numbers requiring greater precision than the 16-bit format can provide. This format can be used for values up to 1 048 575. The 20-bit format requires the PLC program to piece together the additional four bits from word 0 in the input image table (see PLC programming example in Section 5.2 on page 37).

Command Number

The number representing the indicator command is sent in the lower byte of word 1 (bits 0–7). This byte is interpreted as a decimal number.

Tables 3-2 and 3-3 on the following pages list the remote commands that can be specified for IQ plus 800/810 and IQ plus 310A indicators on discrete write commands.

Decimal	Binary	Command	IQ310A
0	0000 0000	Return Status and Weight	N/A
6	0000 0110	Display Gross Weight	GN0<cr>
7	0000 0111	Display Net Weight	GN1<cr>
9	0000 1001	Front Tare	FT<cr>
12	0000 1100	Select LB for Weight Units	LB<cr>
13	0000 1101	Select KG for Weight Units	KG<cr>
14	0000 1110	Print Request	PR<cr>
15	0000 1111	Clear (Reset Indicator)	RS<cr>
21	0001 0101	Clear Tare	CT<cr>
23	0001 0111	Return Gross	XG<cr>
28	0001 1100	Return Net	XN<cr>
33	0010 0001	Return Tare	XT<cr>
37	0010 0101	Return Current Display	XD<cr>
43	0010 1011	Zero	AZ<cr>
44	0010 1100	Enter Tare	AT nnnnnnn<cr>
45	0010 1101	No Operation	None
46-127	0010 1110 0111 1111	Reserved	

Table 3-2. IQ plus 310A Remote Commands

Decimal	Binary	Command	IQ800/810
0	0000 0000	Return Status and Weight	N/A
1	0000 0001	Display Channel 0 (Total)	K0<cr>KBASE<cr>
2	0000 0010	Display Channel 1	K1<cr>KBASE<cr>
3	0000 0011	Display Channel 2	K2<cr>KBASE<cr>
4	0000 0100	Display Channel 3	K3<cr>KBASE<cr>
5	0000 0101	Display Channel 4	K4<cr>KBASE<cr>
6	0000 0110	Display Gross Weight	KGROSS<cr>
7	0000 0111	Display Net Weight	KNET<cr>
9	0000 1001	Acquire Tare	KTARE<cr>
10	0000 1010	Primary Units	KPRIM<cr>
11	0000 1011	Secondary Units	KSEC<cr>
14	0000 1110	Print Request	KPRINT<cr>
15	0000 1111	Clear	KCLR<cr>
16	0001 0000	Clear Accumulator 0 (Total)	K0<cr>KDISPACCUM<cr>KCLR<cr>KCLR<cr>
17	0001 0001	Clear Accumulator 1	K1<cr>KDISPACCUM<cr>KCLR<cr>KCLR<cr>
18	0001 0010	Clear Accumulator 2	K2<cr>KDISPACCUM<cr>KCLR<cr>KCLR<cr>
19	0001 0011	Clear Accumulator 3	K3<cr>KDISPACCUM<cr>KCLR<cr>KCLR<cr>
20	0001 0100	Clear Accumulator 4	K4<cr>KDISPACCUM<cr>KCLR<cr>KCLR<cr>
21	0001 0101	Clear Tare	KDISPTARE<cr>KCLR<cr>KCLR<cr>
22	0001 0110	Return Gross, Channel 0 (Total)	XG#0<cr>
23	0001 0111	Return Gross, Channel 1	XG#1<cr>
24	0001 1000	Return Gross, Channel 2	XG#2<cr>
25	0001 1001	Return Gross, Channel 3	XG#3<cr>
26	0001 1010	Return Gross, Channel 4	XG#4<cr>
27	0001 1011	Return Net, Channel 0 (Total)	XN#0<cr>
28	0001 1100	Return Net, Channel 1	XN#1<cr>
29	0001 1101	Return Net, Channel 2	XN#2<cr>
30	0001 1110	Return Net, Channel 3	XN#3<cr>
31	0001 1111	Return Net, Channel 4	XN#4<cr>
32	0010 0000	Return Tare, Channel 0 (Total)	XT#0<cr>
33	0010 0001	Return Tare, Channel 1	XT#1<cr>
34	0010 0010	Return Tare, Channel 2	XT#2<cr>
35	0010 0011	Return Tare, Channel 3	XT#3<cr>
36	0010 0100	Return Tare, Channel 4	XT#4<cr>
37	0010 0101	Return Current Display	P<cr>
38	0010 0110	Batch Start	BATSTART<cr>
40	0010 1000	Batch Pause	BATPAUSE<cr>
41	0010 1001	Batch Reset	BATRESET<cr>
42	0010 1010	Batch Status	BATSTATUS<cr>
43	0010 1011	Zero	KZERO<cr>
44	0010 1100	Enter Tare	Kn<cr>...Kn<cr>KTARE<cr>

Table 3-3. IQ plus 800/810 Remote Commands

Decimal	Binary	Command	IQ800/810
45	0010 1101	No Operation	None
46	0010 1110	Return Accumulator, Channel 0 (Total)	XA#0<cr>
47	0010 1111	Return Accumulator, Channel 1	XA#1<cr>
48	0011 0000	Return Accumulator, Channel 2	XA#2<cr>
49	0011 0001	Return Accumulator, Channel 3	XA#3<cr>
50	0011 0010	Return Accumulator, Channel 4	XA#4<cr>
51	0011 0011	Return Rate of Change, Channel 0 (Total)	XROC#0<cr>
52	0011 0100	Return Rate of Change, Channel 1	XROC#1<cr>
53	0011 0101	Return Rate of Change, Channel 2	XROC#2<cr>
54	0011 0110	Return Rate of Change, Channel 3	XROC#3<cr>
55	0011 0111	Return Rate of Change, Channel 4	XROC#4<cr>
56	0011 1000	Return Peak, Channel 0 (Total)	XPEAK#0<cr>
57	0011 1001	Return Peak, Channel 1	XPEAK#1<cr>
58	0011 1010	Return Peak, Channel 2	XPEAK#2<cr>
59	0011 1011	Return Peak, Channel 3	XPEAK#3<cr>
60	0011 1100	Return Peak, Channel 4	XPEAK#4<cr>
61	0011 1101	Push Displayed Weight to Accumulator, Channel 0 (Total)	K0<cr>KBASE<cr>KPRINT<cr>
62	0011 1110	Push Displayed Weight to Accumulator, Channel 1	K1<cr>KBASE<cr>KPRINT<cr>
63	0011 1111	Push Displayed Weight to Accumulator, Channel 2	K2<cr>KBASE<cr>KPRINT<cr>
64	0100 0000	Push Displayed Weight to Accumulator, Channel 3	K3<cr>KBASE<cr>KPRINT<cr>
65	0100 0001	Push Displayed Weight to Accumulator, Channel 4	K4<cr>KBASE<cr>KPRINT<cr>
66	0100 0010	Lock indicator front panel	LOCKON<cr>
67	0100 0011	Unlock indicator front panel	LOCKOFF<cr>
68	0100 0100	Set digital output <i>nn</i> on	DON# <i>nn</i> <cr>
69	0100 0101	Set digital output <i>nn</i> off	DOFF# <i>nn</i> <cr>
70–127	0100 0110 0111 1111	Reserved	

Notes: Commands referring to channels 2–4 are valid only for scales with multi-channel capability. For single-channel scales, commands referring to channel 0 return the same information as channel 1.

Commands shown with shading in the command number column (6–21, 43–44, 61–65) do not update weight data in the PLC. Use commands 0 and 22–37 to return weight data to the PLC.

Data written to the input image table by commands 14, 38, 41, and 61–65 is not changed by repeating the command. Successive execution of any of these commands with no other command between executions (for example, command 61 followed by another command 61) has no effect.

Rate of Change and Channel Peak commands are valid only if these options are installed.

Table 3-3. IQ plus 800/810 Remote Commands (Continued)

Using the Output Image Table

The output image table can be thought of as storage for two integers, with each integer one word long. Setting the bit pattern required for a discrete write command can be accomplished by adding the decimal values of those bits that are set to 1, then placing the binary sum in the output image table.

Table 3-4 shows the format of word 1 of the output image table, which includes the command number, weight format, and status data format specifications. Note that the values of bits 13–15 are always 0: bit 15 is reserved; no status data formats are defined for values using bits 13 and 14.

Bit	15	14	13	12	11	10	9	8	7	6	5	4	3	2	1	0
Decimal Value of 1	N/A	N/A	N/A	4096	2048	1024	512	256	128	64	32	16	8	4	2	1
Bit Definition	R	Status Data Format		Wt	Reserved			Command								

Table 3-4. Output Image Table Format (Word 1), Showing Decimal Values for Bits Set to 1

Table 3-5 shows an example of word 1 of the output image table. In the example, bits are set to send the following information on the discrete write command:

- Display Gross Weight command (bits 0–7 = 00000110, 6 decimal)
- 20-bit weight format (bit 11 = 1)
- Remote function status data format (bits 12–14 = 000)

Bit	15	14	13	12	11	10	9	8	7	6	5	4	3	2	1	0
Decimal Value of 1	0	0	0	0	2048	0	0	0	0	0	0	0	0	4	2	0
Bit Definition	R	Status Data Format		Wt	Reserved			Command								

Table 3-5. Example of Output Image Table Format (Word 1)

The integer value of the bits set in the example above are the sum of:

$$\text{Command number (6) + Weight format (2048) + Status Data Format (0) = 2054}$$

Use Table 3-6 to determine the decimal value of word 1 of the output image table for any discrete write command.

Command	+	Weight Format		+	Status Data Format		=	Total Value in Output Image Table
Number		16-bit	0		Remote Function	0		
		20-bit	2048		Batch Function	4096		

Table 3-6. Chart for Finding Decimal Value of Output Image Table (Word 1)

3.2 Input Image Table Format

The Remote I/O Interface places two 16-bit words in the PLC input image table which are read by the PLC controller. The Remote I/O Interface receives data from the indicator, then writes data and status information to the input image table based on parameters specified on the previous discrete write command. A discrete read command is performed when the PLC controller reads the data from the input image table.

The format of the input image table is shown in Table 3-7:

Bit	15	14	13	12	11	10	9	8	7	6	5	4	3	2	1	0
Word 0	v15	v14	v13	v12	v11	v10	v09	v08	v07	v06	v05	v04	v03	v02	v01	v00
Word 1	s10	s09	s08	s07	s06	s05	s04	s03	s02	s01	s00	p	v19	v18	v17	v16

Table 3-7. Input Image Table Format

where:

- v00–v15 16-bit signed integer value (v15 is the sign bit)
- v16–v19 4 high-order bits of 20-bit unsigned integer
- p Polarity bit for 20-bit integer (0 = positive; 1 = negative). Not valid for 16-bit integers.
- s00–s10 Status data

Value

Word 0 of the input image table is used to return weight data to the PLC controller. For values returned in 16-bit format, bit v15 serves as the sign bit. Values returned in 20-bit format use word 0 and bits v16–v19 of word 1, with a polarity bit (word 1, bit 4) to indicate the sign.

Polarity

The polarity bit is used to indicate the sign of values returned in 20-bit format. This bit is not used for 16-bit values.

Status Data

Status data returned on a discrete read command can be either remote function status data or batch function status data, depending on the format specified on the write command.



Caution

Status bits should be routinely checked to ensure that incoming weight data is valid and that communication with the indicator is active.

For example, if communication with the indicator is lost, the weight OK/weight invalid bit (status bit s12) is set. Failure to monitor this bit can cause overflows or accidents if conditional filling operations are based on old data.

Tables 3-8 and 3-9 on page 15 show the format of status bits used for remote and batch function status data.

About the Channel Bit

Word 1, bit 7 (status bit 02) serves as a channel bit for multichannel indicators using the discrete commands listed below:

- Display Channel (Commands 1–5)
- Return Gross (Commands 22–26)
- Return Net (Commands 27–31)
- Return Tare (Commands 32–36)

The channel bit is set to 0 if one of the commands listed above is used to make Channel 1 (or Channel 0) the active channel. If one of the listed commands is used to make Channel 2, 3, or 4 the active channel, the channel bit is set to 1.

The channel bit is included in both the remote and batch function status data formats.

Word 1 Bit	Status Bit	Remote Function Status Data	
		Value=0	Value=1
05	s00	Reserved	
06	s01		
07	s02	Channel = 0 or 1	Channel = 2, 3 or 4
08	s03	Gross	Net
09	s04	No tare	Tare acquired
10	s05	Primary (LB)	Secondary (KG)
11	s06	Standstill	In motion
12	s07	Weight OK	Weight invalid / Over-range
13	s08	Not zero	Center of zero
14	s09	Tare not entered	Tare entered
15	s10	Reserved	

Table 3-8. Remote Function Status Data Format

Word 1 Bit	Status Bit	Batch Function Status Data	
		Value=0	Value=1
05	s00	Reserved	
06	s01		
07	s02	Channel = 0 or 1	Channel = 2, 3, or 4
08	s03	Alarm OFF	Alarm ON
09	s04		Batch stopped
10	s05		Batch running
11	s06		Batch paused
12	s07	Digital Input 1 OFF	Digital Input 1 ON
13	s08	Digital Input 2 OFF	Digital Input 2 ON
14	s09	Digital Input 3 OFF	Digital Input 3 ON
15	s10	Reserved	

Table 3-9. Batch Function Status Data Format

DISCONTINUED

4.0 Block Transfer Commands

The Remote I/O Interface supports block transfer commands for the IQ plus 800/810 and IQ plus 310A indicators. These commands allow the PLC controller to exchange larger blocks of data with the indicator, including gross, net, tare, and accumulator values, channel peak and rate of change values (for indicators with these options installed), and partial setpoint configuration. Some commands are not supported for the IQ plus 310A indicator.

Supported Commands

Table 4-1 shows the block write and block read commands supported by the Remote I/O Interface.

Command Number	Command Name	Block Write Command Length*	Block Read Command Length*	Valid for IQ plus 310A
1	Set Tare Value	4	2	Yes
2	Set Setpoint Values	11	2	—
3	Read Setpoint Values	2	11	—
4	Read Accumulator Value	2	4	—
5	Read Channel Peak Value	2	4	—
6	Read Rate of Change Value	2	4	—
7	Read Tare Value	2	4	Yes
8	Read Gross Value	2	4	Yes
9	Read Net Value	2	4	Yes
10	Read Multiple Weights	3	23	—
11	Set Multiple Setpoint Values	4 – 42**	2	—
12	Read Multiple Setpoint Values	2	4 – 42**	—
13	Set Batching State	2	2	—
* Command lengths expressed as number of words				
** Length of command depends on number of setpoints specified				

Table 4-1. Supported Block Transfer Commands

Using Block Transfer Commands

When using block transfer commands, each action is accomplished by sending a block write command followed by a block read command.

For example, to set a tare value, a Block Write Command 1 (Set Tare Value) consisting of the command number (1), indicator channel number, and the tare value itself is sent to the Remote I/O Interface. Next, a Block Read Command 1 is issued by the PLC controller. The two words of data returned to the PLC contain the number of the previous block write command (1) and a response code indicating whether or not the block write command was successful. If the command failed, the command number returned in the block read is set negative (using 2's complement).

The following sections provide detailed descriptions of the block transfer commands. Each section shows the format used by the block write command, followed by that of the block read command. See Section 5.3 on page 38 for an example of using block transfer to set and read setpoint values.

4.1 Set Tare Value

The Set Tare Value block write command is used to write a tare value to the indicator. Table 4-2 shows the format of the command:

Word	Bit Number															Word Contents	
	15	14	13	12	11	10	9	8	7	6	5	4	3	2	1		0
0	0	0	0	0	0	0	0	0	0	0	0	0	0	0	0	1	Command Number (1)
1	0	0	0	0	0	0	0	0	0	0	0	0	0	c2	c1	c0	Channel Number (0–4)
2	v31										v16					Tare Value (MSW)	
3	v15										v00					Tare Value (LSW)	

Table 4-2. Block Write Command 1: Set Tare Value

Command Number

Specifies the Set Tare Value command number, 1.

Channel Number

Specifies the channel number for the tare value being set. Valid values are 0 through 4. Specify channel 1 for single-channel indicators.

Tare Value

Specifies the tare value being set.

NOTE: For IQ plus 310A indicators only, tare values must be sent as integers. The tare value must be manipulated to include digits for any decimal positions configured for the indicator.

For example, to send a tare value of 12.5 to an IQ plus 310A configured for two decimal places (0.00), the PLC controller must format the tare value as 1250. This value is interpreted by the indicator as 12.50.

Block read command 1 returns a response code to the PLC controller, indicating whether or not the Set Tare Value block write command was successful. Possible values for the response code field are:

- 0 00 Command successful
- 1 01 Command failed
- 2 10 Block write command format not valid

If the block write command failed, the command number returned in word 0 is set negative (-1). Table 4-3 shows the format of the block read command.

Word	Bit Number															Word Contents	
	15	14	13	12	11	10	9	8	7	6	5	4	3	2	1		0
0	0	0	0	0	0	0	0	0	0	0	0	0	0	0	0	1	Command Number (1)
1	0	0	0	0	0	0	0	0	0	0	0	0	0	0	r1	r0	Response Code (0–2)

Table 4-3. Block Read Command 1: Set Tare Value (Read Response Code)

4.2 Set Setpoint Values

The Set Setpoint Values block write command is used to write setpoint information to the indicator. Table 4-4 shows the format of the command:

Word	Bit Number																Word Contents
	15	14	13	12	11	10	9	8	7	6	5	4	3	2	1	0	
0	0	0	0	0	0	0	0	0	0	0	0	0	0	0	1	0	Command Number (2)
1	0	0	0	0	0	0	0	0	0	0	0	n4	n3	n2	n1	n0	Setpoint Number (1–20)
2	0	0	0	0	0	0	0	0	0	0	0	k4	k3	k2	k1	k0	Setpoint Kind (0–18)
3	v31 _____ Setpoint Value _____										v16						Setpoint Value (MSW)
4	v15 _____										v00						Setpoint Value (LSW)
5	b31 _____										b16						Band Value (MSW)
6	b15 _____										b00						Band Value (LSW)
7	h31 _____										h16						Hysteresis Value (MSW)
8	h15 _____										h00						Hysteresis Value (LSW)
9	p31 _____										p16						Preact Value (MSW)
10	p15 _____										p00						Preact Value (LSW)

Table 4-4. Block Write Command 2: Set Setpoint Values

Command Number

Specifies the Set Setpoint Values command number, 2.

Setpoint Number

Specifies the setpoint number being configured. Valid values are 1 through 20, decimal.

Setpoint Kind

Specifies the kind of setpoint being configured. Table 4-5 on page 19 shows the kinds of setpoints that can be specified on this parameter:

Value	Kind	Description
0	OFF	Setpoint turned off/ignored.
1	GROSSSP	Gross setpoint. Trips when the current gross weight matches this value.
2	NETSP	Net setpoint. Trips when the current net weight matches this value.
3	+RELSP	Positive relative setpoint. Trips at a specific value above the referenced setpoint.
4	-RELSP	Negative relative setpoint. Trips at a specific value below the referenced setpoint.
5	%RELSP	Percentile relative setpoint. Trips at a specific percentage value of the referenced setpoint.
6	PAUSE	Pauses the batch sequence indefinitely. Operator must activate the START digital input to continue processing.
7	DELAY	Delays the batch sequence for a specified time. The length of the delay (in tenths of a second) is specified on the Value parameter.
8	WAITSS	Wait for standstill. Pauses the batch sequence until the scale is at standstill.
9	COUNTER	Specifies the number of consecutive batch sequences to perform.
10	AUTOJOG	Automatically jogs the previous filling operation.
11	COZ	Center of zero. The digital output associated with this setpoint is activated when the scale is at center of zero. No value is required for this setpoint.
12	INMOTON	In motion. The digital output associated with this setpoint is activated when the scale is not at standstill. No value is required for this setpoint.
13	INRANGE	In range. The digital output associated with this setpoint is activated when the scale is within capacity range. No value is required for this setpoint.
14	-GROSS	Negative gross weight. The digital output associated with this setpoint is activated when the gross weight reading is less than zero. No value is required for this setpoint.
15	-NET	Negative net weight. The digital output associated with this setpoint is activated when the net weight reading is less than zero. No value is required for this setpoint.
16	BATCHPR	Batch processing signal. The digital output associated with this setpoint is activated whenever a batch sequence is in progress. No value is required for this setpoint.
17	TIMER	Tracks the progress of a batch sequence based on a timer. The timer value, specified in tenths of a second on the Value parameter, determines the length of time allowed between start and end setpoints. The indicator Start and End parameters are used to specify the start and end setpoints. If the End setpoint is not reached before the timer expires, the digital output associated with this setpoint is activated.
18	CONCUR	Allows a digital output to remain active over a specified portion of the batch sequence. Two types of Concur setpoints can be configured: Type 1: The digital output associated with this setpoint becomes active when the Start setpoint becomes the current batch step and remains active until the End setpoint becomes the current batch step. Type 2: The digital output associated with this setpoint becomes active when the Start setpoint becomes the current batch step and remains active until a timer expires. The indicator Start and End parameters are used to specify start and end setpoints. The timer value is specified in tenths of a second on the Value parameter.

Table 4-5. Setpoint Kind Values

Table 4-6 lists the values that can be specified for the Setpoint Kind parameter. Shaded areas in the right columns indicate that the setpoint type can be used as a continuous or batch step setpoint.

- Continuous setpoints are free-running, becoming active based on a specified condition or weight value.
- Batch setpoints run sequentially, one at a time, for control of batch processing operations.

Decimal Value	Bit Number					Kind	Continuous or Batch Step	
	k4	k3	k2	k1	k0		Cont	Batch
0	0	0	0	0	0	OFF		
1	0	0	0	0	1	GROSSSP		
2	0	0	0	1	0	NETSP		
3	0	0	0	1	1	+RELSP		
4	0	0	1	0	0	-RELSP		
5	0	0	1	0	1	%RELSP		
6	0	0	1	1	0	PAUSE		
7	0	0	1	1	1	DELAY		
8	0	1	0	0	0	WAITSS		
9	0	1	0	0	1	COUNTER		
10	0	1	0	1	0	AUTOJOG		
11	0	1	0	1	1	COZ		
12	0	1	1	0	0	INMOTON		
13	0	1	1	0	1	INRANGE		
14	0	1	1	1	0	-GROSS		
15	0	1	1	1	1	-NET		
16	1	0	0	0	0	BATCHPR		
17	1	0	0	0	1	TIMER		
18	1	0	0	1	0	CONCUR		

Table 4-6. Setpoint Kind Values

Setpoint Value

Specifies the value used as input for several setpoint types. Values specified can represent weight, time (in tenths of a second), or the number of repetitions used by counter setpoints.

Band Value

Specifies the bandwidth value used when the TRIP parameter is set to INBAND or OUTBAND. The bandwidth value is set to fall equally on either side of the setpoint value.

Hysteresis

Specifies a band on either side of the setpoint value that must be exceeded before a continuous setpoint will trip on again once it has shut off.

Preact Value

Specifies the amount of adjustment used by the PRACT parameter. This parameter is used only if PRACT is set to ON or LEARN.

See the *IQ plus 800/810 Installation Manual* for detailed information about setpoint configuration.

Block read command 2 returns a response code to the PLC controller, indicating whether or not the Set Setpoint Values block write command was successful. Possible values for the response code field are:

- 0 00 Command successful
- 1 01 Command failed
- 2 10 Block write command format not valid

If the block write command failed, the command number returned in word 0 is set negative (-2). Table 4-7 shows the format of the block read command.

Word	Bit Number															Word Contents	
	15	14	13	12	11	10	9	8	7	6	5	4	3	2	1		0
0	0	0	0	0	0	0	0	0	0	0	0	0	0	0	1	0	Command Number (2)
1	0	0	0	0	0	0	0	0	0	0	0	0	0	0	r1	r0	Response Code (0-2)

Table 4-7. Block Read Command 2: Set Setpoint Values (Read Response Code)

4.3 Read Setpoint Values

The Read Setpoint Values block write command is used to read setpoint values from the indicator. Table 4-8 shows the format of the command:

Word	Bit Number															Word Contents	
	15	14	13	12	11	10	9	8	7	6	5	4	3	2	1		0
0	0	0	0	0	0	0	0	0	0	0	0	0	0	0	1	1	Command Number (3)
1	0	0	0	0	0	0	0	0	0	0	0	n4	n3	n2	n1	n0	Setpoint Number (1-20)

Table 4-8. Block Write Command 3: Read Setpoint Values

Command Number

Specifies the Read Setpoint Values command number, 3.

Setpoint Number

Specifies the number of the setpoint being read. Valid values are 1 through 20.

Block read command 3 returns an 11-word block of setpoint values to the PLC controller. If the block write command failed, the command number returned in word 0 is set negative (-3). Table 4-9 shows the format of the block read command.

Word	Bit Number															Word Contents	
	15	14	13	12	11	10	9	8	7	6	5	4	3	2	1		0
0	0	0	0	0	0	0	0	0	0	0	0	0	0	0	1	1	Command Number (3)
1	0	0	0	0	0	0	0	0	0	0	0	n4	n3	n2	n1	n0	Setpoint Number (1-20)
2	0	0	0	0	0	0	0	0	0	0	0	k4	k3	k2	k1	k0	Setpoint Kind (0-18)
3	v31										Setpoint Value					v16	Setpoint Value (MSW)
4	v15										Setpoint Value					v00	Setpoint Value (LSW)
5	b31										Band Value					b16	Band Value (MSW)
6	b15										Band Value					b00	Band Value (LSW)
7	h31										Hysteresis Value					h16	Hysteresis Value (MSW)
8	h15										Hysteresis Value					h00	Hysteresis Value (LSW)
9	p31										Preact Value					p16	Preact Value (MSW)
10	p15										Preact Value					p00	Preact Value (LSW)

Table 4-9. Block Read Command 3: Read Setpoint Values

4.4 Read Accumulator Value

The Read Accumulator Value block write command is used to read accumulator values from the indicator. Table 4-10 shows the format of the command:

Word	Bit Number																Word Contents
	15	14	13	12	11	10	9	8	7	6	5	4	3	2	1	0	
0	0	0	0	0	0	0	0	0	0	0	0	0	0	1	0	0	Command Number (4)
1	0	0	0	0	0	0	0	0	0	0	0	0	0	a2	a1	a0	Accumulator Number (0-4)

Table 4-10. Block Write Command 4: Read Accumulator Value

Command Number

Specifies the Read Accumulator Value command number, 4.

Accumulator Number

Specifies the number of the accumulator being read. Valid values are 0 through 4. Specify channel 1 for single-channel indicators.

Block read command 4 returns a 2-word accumulator value to the PLC controller. If the block write command failed, the command number returned in word 0 is set negative (-4). Table 4-11 shows the format of the block read command.

Word	Bit Number																Word Contents
	15	14	13	12	11	10	9	8	7	6	5	4	3	2	1	0	
0	0	0	0	0	0	0	0	0	0	0	0	0	0	1	0	0	Command Number (4)
1	0	0	0	0	0	0	0	0	0	0	0	0	0	a2	a1	a0	Accumulator Number (0-4)
2	v31 Accumulator Value															v16	Accumulator Value (MSW)
3	v15															v00	Accumulator Value (LSW)

Table 4-11. Block Read Command 4: Read Accumulator Value

4.5 Read Channel Peak Value

The Read Channel Peak Value block write command is used to read channel peak values from the indicator. This command is valid only if the channel peak option is installed in the indicator. Table 4-12 shows the format of the command:

Word	Bit Number															Word Contents	
	15	14	13	12	11	10	9	8	7	6	5	4	3	2	1		0
0	0	0	0	0	0	0	0	0	0	0	0	0	0	1	0	1	Command Number (5)
1	0	0	0	0	0	0	0	0	0	0	0	0	0	c2	c1	c0	Channel Number (0–4)

Table 4-12. Block Write Command 5: Read Channel Peak Value

Command Number

Specifies the Read Channel Peak Value command number, 5.

Channel Number

Specifies the channel number for the channel peak value being read. Valid values are 0 through 4. Specify channel 1 for single-channel indicators.

Block read command 5 returns a 2-word peak value to the PLC controller. If the block write command failed, the command number returned in word 0 is set negative (-5). Table 4-13 shows the format of the block read command.

Word	Bit Number															Word Contents	
	15	14	13	12	11	10	9	8	7	6	5	4	3	2	1		0
0	0	0	0	0	0	0	0	0	0	0	0	0	0	1	0	1	Command Number (5)
1	0	0	0	0	0	0	0	0	0	0	0	0	0	c2	c1	c0	Channel Number (0–4)
2	v31												v16			Peak Value (MSW)	
3	v15												v00			Peak Value (LSW)	

Table 4-13. Block Read Command 5: Read Channel Peak Value

4.6 Read Rate of Change Value

The Read Rate of Change Value block write command is used to read rate of change values from the indicator. This command is valid only if the rate of change option is installed in the indicator. Table 4-14 shows the format of the command:

Word	Bit Number																Word Contents
	15	14	13	12	11	10	9	8	7	6	5	4	3	2	1	0	
0	0	0	0	0	0	0	0	0	0	0	0	0	0	1	1	0	Command Number (6)
1	0	0	0	0	0	0	0	0	0	0	0	0	0	c2	c1	c0	Channel Number (0-4)

Table 4-14. Block Write Command 6: Read Rate of Change Value

Command Number

Specifies the Read Rate of Change Value command number, 6.

Channel Number

Specifies the channel number for the rate of change being read. Valid values are 0 through 4. Specify channel 1 for single-channel indicators.

Block read command 6 returns a 2-word rate of change value to the PLC controller. If the block write command failed, the command number returned in word 0 is set negative (-6). Table 4-15 shows the format of the block read command.

Word	Bit Number																Word Contents
	15	14	13	12	11	10	9	8	7	6	5	4	3	2	1	0	
0	0	0	0	0	0	0	0	0	0	0	0	0	0	1	1	0	Command Number (6)
1	0	0	0	0	0	0	0	0	0	0	0	0	0	c2	c1	c0	Channel Number (0-4)
2	v31 _____ Rate of Change _____ v16															ROC Value (MSW)	
3	v15 _____ Value _____ v00															ROC Value (LSW)	

Table 4-15. Block Read Command 6: Read Rate of Change Value

4.7 Read Tare Value

The Read Tare Value block write command is used to read a tare value from the indicator. Table 4-16 shows the format of the command:

Word	Bit Number															Word Contents	
	15	14	13	12	11	10	9	8	7	6	5	4	3	2	1		0
0	0	0	0	0	0	0	0	0	0	0	0	0	0	1	1	1	Command Number (7)
1	0	0	0	0	0	0	0	0	0	0	0	0	0	c2	c1	c0	Channel Number (0-4)

Table 4-16. Block Write Command 7: Read Tare Value

Command Number

Specifies the Set Tare Value command number, 7.

Channel Number

Specifies the channel number for the tare value being read. Valid values are 0-4. Specify channel 1 for single-channel indicators.

Block read command 7 returns a 2-word tare value to the PLC controller. If the block write command failed, the command number returned in word 0 is set negative (-7). Table 4-17 shows the format of the block read command.

Word	Bit Number															Word Contents	
	15	14	13	12	11	10	9	8	7	6	5	4	3	2	1		0
0	0	0	0	0	0	0	0	0	0	0	0	0	0	1	1	1	Command Number (7)
1	0	0	0	0	0	0	0	0	0	0	0	0	0	c2	c1	c0	Channel Number (0-4)
2	v31														v16	Tare Value (MSW)	
3	v15														v00	Tare Value (LSW)	

Table 4-17. Block Read Command 7: Read Tare Value

4.8 Read Gross Value

The Read Gross Value block write command is used to read a gross value from the indicator. Table 4-18 shows the format of the command:

Word	Bit Number																Word Contents
	15	14	13	12	11	10	9	8	7	6	5	4	3	2	1	0	
0	0	0	0	0	0	0	0	0	0	0	0	0	1	0	0	0	Command Number (8)
1	0	0	0	0	0	0	0	0	0	0	0	0	0	c2	c1	c0	Channel Number (0–4)

Table 4-18. Block Write Command 8: Read Gross Value

Command Number

Specifies the Read Gross Value command number, 8.

Channel Number

Specifies the channel number for the gross value being read. Valid values are 0 through 4. Specify channel 1 for single-channel indicators.

Block read command 8 returns a 2-word gross value to the PLC controller. If the block write command failed, the command number returned in word 0 is set negative (-8). Table 4-19 shows the format of the block read command.

Word	Bit Number																Word Contents
	15	14	13	12	11	10	9	8	7	6	5	4	3	2	1	0	
0	0	0	0	0	0	0	0	0	0	0	0	0	1	0	0	0	Command Number (8)
1	0	0	0	0	0	0	0	0	0	0	0	0	0	c2	c1	c0	Channel Number (0–4)
2	v31														v16	Gross Value (MSW)	
3	v15														v00	Gross Value (LSW)	

Table 4-19. Block Read Command 8: Read Gross Value

4.9 Read Net Value

The Read Net Value block write command is used to read a net value from the indicator. Table 4-20 shows the format of the command:

Word	Bit Number															Word Contents	
	15	14	13	12	11	10	9	8	7	6	5	4	3	2	1		0
0	0	0	0	0	0	0	0	0	0	0	0	0	1	0	0	1	Command Number (9)
1	0	0	0	0	0	0	0	0	0	0	0	0	0	c2	c1	c0	Channel Number (0–4)

Table 4-20. Block Write Command 9: Read Net Value

Command Number

Specifies the Read Net Value command number, 9.

Channel Number

Specifies the channel number for the net value being read. Valid values are 0 through 4. Specify channel 1 for single-channel indicators.

Block read command 9 returns a 2-word net value to the PLC controller. If the block write command failed, the command number returned in word 0 is set negative (-9). Table 4-21 shows the format of the block read command.

Word	Bit Number															Word Contents	
	15	14	13	12	11	10	9	8	7	6	5	4	3	2	1		0
0	0	0	0	0	0	0	0	0	0	0	0	0	1	0	0	1	Command Number (9)
1	0	0	0	0	0	0	0	0	0	0	0	0	0	c2	c1	c0	Channel Number (0–4)
2	v31										v16						Net Value (MSW)
3	v15										v00						Net Value (LSW)

Table 4-21. Block Read Command 9: Read Net Value

4.10 Read Multiple Weights

The Read Multiple Weights block write command is used to read gross, net, or both gross and net values for one or more indicator channels. Table 4-22 shows the format of the command:

Word	Bit Number																Word Contents
	15	14	13	12	11	10	9	8	7	6	5	4	3	2	1	0	
0	0	0	0	0	0	0	0	0	0	0	0	0	1	0	1	0	Command Number (10)
1	0	0	0	0	0	0	0	0	0	0	0	0	c3	c2	c1	c0	Channel Number (0–8)
2	0	0	0	0	0	0	0	0	0	0	0	0	0	t2	t1	t0	Weight Type (0–2)

Table 4-22. Block Write Command 10: Read Multiple Weights

Command Number

Specifies the Read Multiple Weights command number, 10.

Channel Number

Specifies the channel number for the weight values being read. Valid values are:

0	0000	Channel 0 (Total)
1	0001	Channel 1
2	0010	Channel 2
3	0011	Channel 3
4	0100	Channel 4
5	0101	All Channels (0–4)
6	0110	Channels 1 and 2
7	0111	Channels 1 and 3
8	1000	Channels 1, 3, and 4

Specify channel 1 (0001) for single-channel indicators.

Weight Type

Specifies the type of weight data being read. Valid values are:

0	00	Gross
1	01	Net
2	10	Gross and Net

Block read command 10 returns a 23-word block of data to the PLC controller that contains all weights requested on the block write command. Table 4-23 on page 29 shows the format of the command. If the block write command failed, the command number returned in word 0 is set negative (-10).

Word	Bit Number																Word Contents		
	15	14	13	12	11	10	9	8	7	6	5	4	3	2	1	0			
0	0	0	0	0	0	0	0	0	0	0	0	0	1	0	1	0	Command Number (10)		
1	0	0	0	0	0	0	0	0	0	0	0	0	c3	c2	c1	c0	Channel Number (0–8)		
2	0	0	0	0	0	0	0	0	0	0	0	0	0	t2	t1	t0	Weight Type (0–2)		
3	v31								Channel 0								v16		Ch 0 Gross Value (MSW)
4	v15								Gross Value								v00		Ch 0 Gross Value (LSW)
5	v31								Channel 1								v16		Ch 1 Gross Value (MSW)
6	v15								Gross Value								v00		Ch 1 Gross Value (LSW)
7	v31								Channel 2								v16		Ch 2 Gross Value (MSW)
8	v15								Gross Value								v00		Ch 2 Gross Value (LSW)
9	v31								Channel 3								v16		Ch 3 Gross Value (MSW)
10	v15								Gross Value								v00		Ch 3 Gross Value (LSW)
11	v31								Channel 4								v16		Ch 4 Gross Value (MSW)
12	v15								Gross Value								v00		Ch 4 Gross Value (LSW)
13	v31								Channel 0								v16		Ch 0 Net Value (MSW)
14	v15								Net Value								v00		Ch 0 Net Value (LSW)
15	v31								Channel 1								v16		Ch 1 Net Value (MSW)
16	v15								Net Value								v00		Ch 1 Net Value (LSW)
17	v31								Channel 2								v16		Ch 2 Net Value (MSW)
18	v15								Net Value								v00		Ch 2 Net Value (LSW)
19	v31								Channel 3								v16		Ch 3 Net Value (MSW)
20	v15								Net Value								v00		Ch 3 Net Value (LSW)
21	v31								Channel 4								v16		Ch 4 Net Value (MSW)
22	v15								Net Value								v00		Ch 4 Net Value (LSW)

Table 4-23. Block Read Command 10: Read Multiple Weights

4.11 Set Multiple Setpoint Values

The Set Multiple Setpoint Values block write command is used to set the setpoint value for one or more setpoints. Depending on the number of setpoint values set, the command length can vary from 4 to 42 words. Table 4-24 shows the format of the command:

Word	Bit Number																Word Contents
	15	14	13	12	11	10	9	8	7	6	5	4	3	2	1	0	
0	0	0	0	0	0	0	0	0	0	0	0	0	1	0	1	1	Command Number (11)
1	0	0	0	0	0	0	0	0	0	0	0	n4	n3	n2	n1	n0	Set Through Setpoint Number (1–20)
2	v31 _____ v16															Setpoint 1 Value (MSW)	
3	v15 _____ v00															Setpoint 1 Value (LSW)	
4	v31 _____ v16															Setpoint 2 Value	
5	v15 _____ v00																
6	v31 _____ v16															Setpoint 3 Value	
7	v15 _____ v00																
8	v31 _____ v16															Setpoint 4 Value	
9	v15 _____ v00																
10	v31 _____ v16															Setpoint 5 Value	
11	v15 _____ v00																
12	v31 _____ v16															Setpoint 6 Value	
13	v15 _____ v00																
14	v31 _____ v16															Setpoint 7 Value	
15	v15 _____ v00																
16	v31 _____ v16															Setpoint 8 Value	
17	v15 _____ v00																
18	v31 _____ v16															Setpoint 9 Value	
19	v15 _____ v00																
20	v31 _____ v16															Setpoint 10 Value	
21	v15 _____ v00																
22	v31 _____ v16															Setpoint 11 Value	
23	v15 _____ v00																
24	v31 _____ v16															Setpoint 12 Value	
25	v15 _____ v00																
26	v31 _____ v16															Setpoint 13 Value	
27	v15 _____ v00																
28	v31 _____ v16															Setpoint 14 Value	
29	v15 _____ v00																
30	v31 _____ v16															Setpoint 15 Value	
31	v15 _____ v00																
32	v31 _____ v16															Setpoint 16 Value	
33	v15 _____ v00																
34	v31 _____ v16															Setpoint 17 Value	
35	v15 _____ v00																

Table 4-24. Block Write Command 11: Set Multiple Setpoint Values

Word	Bit Number																Word Contents
	15	14	13	12	11	10	9	8	7	6	5	4	3	2	1	0	
36	v31															v16	Setpoint 18 Value
37	v15															v00	
38	v31															v16	Setpoint 19 Value
39	v15															v00	
40	v31															v16	Setpoint 20 Value
41	v15															v00	

Table 4-24. Block Write Command 11: Set Multiple Setpoint Values (Continued)

Command Number

Specifies the Set Multiple Setpoint Values command number, 11.

Set Through Setpoint Number

Specifies the setpoints for which setpoint values are set. Valid values are 1 through 20. Setpoint values are set for all setpoints less than or equal to the number specified. For example, if the Set Through Setpoint Number is 4, setpoint values are entered for setpoints 1–4, using words 2–9.

Block read command 11 returns a response code to the PLC controller, indicating whether or not the Set Multiple Setpoint Values block write command was successful. Possible values for the response code field are:

- 0 00 Command successful
- 1 01 Command failed
- 2 10 Block write command format not valid

If the block write command failed, the command number returned in word 0 is set negative (-11). Table 4-25 shows the format of the block read command.

Word	Bit Number																Word Contents
	15	14	13	12	11	10	9	8	7	6	5	4	3	2	1	0	
0	0	0	0	0	0	0	0	0	0	0	0	0	1	0	1	1	Command Number (11)
1	0	0	0	0	0	0	0	0	0	0	0	0	0	0	r1	r0	Response Code (0–2)

Table 4-25. Block Read Command 12: Set Multiple Setpoint Values

4.12 Read Multiple Setpoint Values

The Read Multiple Setpoint Values block write command is used to read the setpoint value for one or more setpoints from the indicator. Table 4-26 shows the format of the command:

Word	Bit Number																Word Contents
	15	14	13	12	11	10	9	8	7	6	5	4	3	2	1	0	
0	0	0	0	0	0	0	0	0	0	0	0	0	1	1	0	0	Command Number (12)
1	0	0	0	0	0	0	0	0	0	0	0	n4	n3	n2	n1	n0	Read Through Setpoint Number (1–20)

Table 4-26. Block Write Command 12: Read Multiple Setpoint Values

Command Number

Specifies the Read Multiple Setpoint Values command number, 12.

Read Through Setpoint Number

Specifies the setpoints for which setpoint values are read. Valid values are 1 through 20. Setpoint values are retrieved for all setpoints less than or equal to the number specified. For example, if the Read Through Setpoint Number is 6, setpoint values for setpoints 1 through 6 will be returned by the block read command.

The Read Multiple Setpoint Values block read command returns the requested setpoint values and a response code to the PLC controller. Depending on the number of setpoint values requested, the command length can vary from 4 to 42 words. Table 4-27 shows the format of the command if the values of all 20 setpoints are read.

Word	Bit Number																Word Contents
	15	14	13	12	11	10	9	8	7	6	5	4	3	2	1	0	
0	0	0	0	0	0	0	0	0	0	0	0	0	1	1	0	0	Command Number (12)
1	0	0	0	0	0	0	0	0	0	0	0	0	0	0	r1	r0	Response Code (0–2)
2	v31															v16	Setpoint 1 Value (MSW)
3	v15															v00	Setpoint 1 Value (LSW)
4	v31															v16	Setpoint 2 Value
5	v15															v00	
6	v31															v16	Setpoint 3 Value
7	v15															v00	
8	v31															v16	Setpoint 4 Value
9	v15															v00	
10	v31															v16	Setpoint 5 Value
11	v15															v00	
12	v31															v16	Setpoint 6 Value
13	v15															v00	
14	v31															v16	Setpoint 7 Value
15	v15															v00	
16	v31															v16	Setpoint 8 Value
17	v15															v00	
18	v31															v16	Setpoint 9 Value
19	v15															v00	
20	v31															v16	Setpoint 10 Value
21	v15															v00	

Table 4-27. Block Read Command 12: Read Multiple Setpoint Values

Word	Bit Number															Word Contents
	15	14	13	12	11	10	9	8	7	6	5	4	3	2	1	
22	v31 _____ Setpoint 11 Value _____ v16															Setpoint 11 Value
23	v15 _____ v00															
24	v31 _____ Setpoint 12 Value _____ v16															Setpoint 12 Value
25	v15 _____ v00															
26	v31 _____ Setpoint 13 Value _____ v16															Setpoint 13 Value
27	v15 _____ v00															
28	v31 _____ Setpoint 14 Value _____ v16															Setpoint 14 Value
29	v15 _____ v00															
30	v31 _____ Setpoint 15 Value _____ v16															Setpoint 15 Value
31	v15 _____ v00															
32	v31 _____ Setpoint 16 Value _____ v16															Setpoint 16 Value
33	v15 _____ v00															
34	v31 _____ Setpoint 17 Value _____ v16															Setpoint 17 Value
35	v15 _____ v00															
36	v31 _____ Setpoint 18 Value _____ v16															Setpoint 18 Value
37	v15 _____ v00															
38	v31 _____ Setpoint 19 Value _____ v16															Setpoint 19 Value
39	v15 _____ v00															
40	v31 _____ Setpoint 20 Value _____ v16															Setpoint 20 Value
41	v15 _____ v00															

Table 4-27. Block Read Command 12: Read Multiple Setpoint Values (Continued)

The response code indicates whether or not the Read Multiple Setpoint Values block write command was successful. Possible values for the response code field are:

- 0 00 Command successful
- 1 01 Command failed
- 2 10 Block write command format not valid

If the block write command failed, the command number returned in word 0 is set negative (-12).

4.13 Set Batching State

The Set Batching State block write command is used to set the batching (BATCHNG) parameter to OFF, AUTO, or MANUAL. Table 4-28 shows the format of the command:

Word	Bit Number																Word Contents
	15	14	13	12	11	10	9	8	7	6	5	4	3	2	1	0	
0	0	0	0	0	0	0	0	0	0	0	0	0	1	1	0	1	Command Number (13)
1	0	0	0	0	0	0	0	0	0	0	0	0	0	0	s1	s0	Batching State (0-2)

Table 4-28. Block Write Command 13: Set Batching State

Command Number

Specifies the Set Batching State command number, 13.

Batching State

Specifies the type of batching enabled for the indicator. Possible values are:

- 0 00 Off
- 1 01 Automatic
- 2 10 Manual

The block read command returns a response code to the PLC controller, indicating whether or not the Set Batching State block write command was successful. Possible values for the response code field are:

- 0 00 Command successful
- 1 01 Command failed
- 2 10 Block write command format not valid

If the block write command failed, the command number returned in word 0 is set negative (-13). Table 4-29 shows the format of the block read command.

Word	Bit Number																Word Contents
	15	14	13	12	11	10	9	8	7	6	5	4	3	2	1	0	
0	0	0	0	0	0	0	0	0	0	0	0	0	1	1	0	1	Command Number (13)
1	0	0	0	0	0	0	0	0	0	0	0	0	0	0	r1	r0	Response Code (0-2)

Table 4-29. Block Read Command 13: Set Batching State

5.0 Operation

The examples on the following pages provide PLC programming examples for using the Remote I/O Interface.

5.1 Test Program for Verifying Remote I/O Interface Operation

The following programming example writes a series of discrete commands to the Remote I/O Interface and checks the status bits returned in the input image table to confirm completion of each command. This example assumes the Remote I/O scanner to be in slot #2, with the Remote I/O Interface at rack address 0, quarter 0.

NOTES:

1. This program can be edited and used to test communications between the PLC and the Remote I/O Interface.
2. The COMMAND WORD must be zeroed after checking the status bits to confirm that the command has been executed.

DISCONTINUED

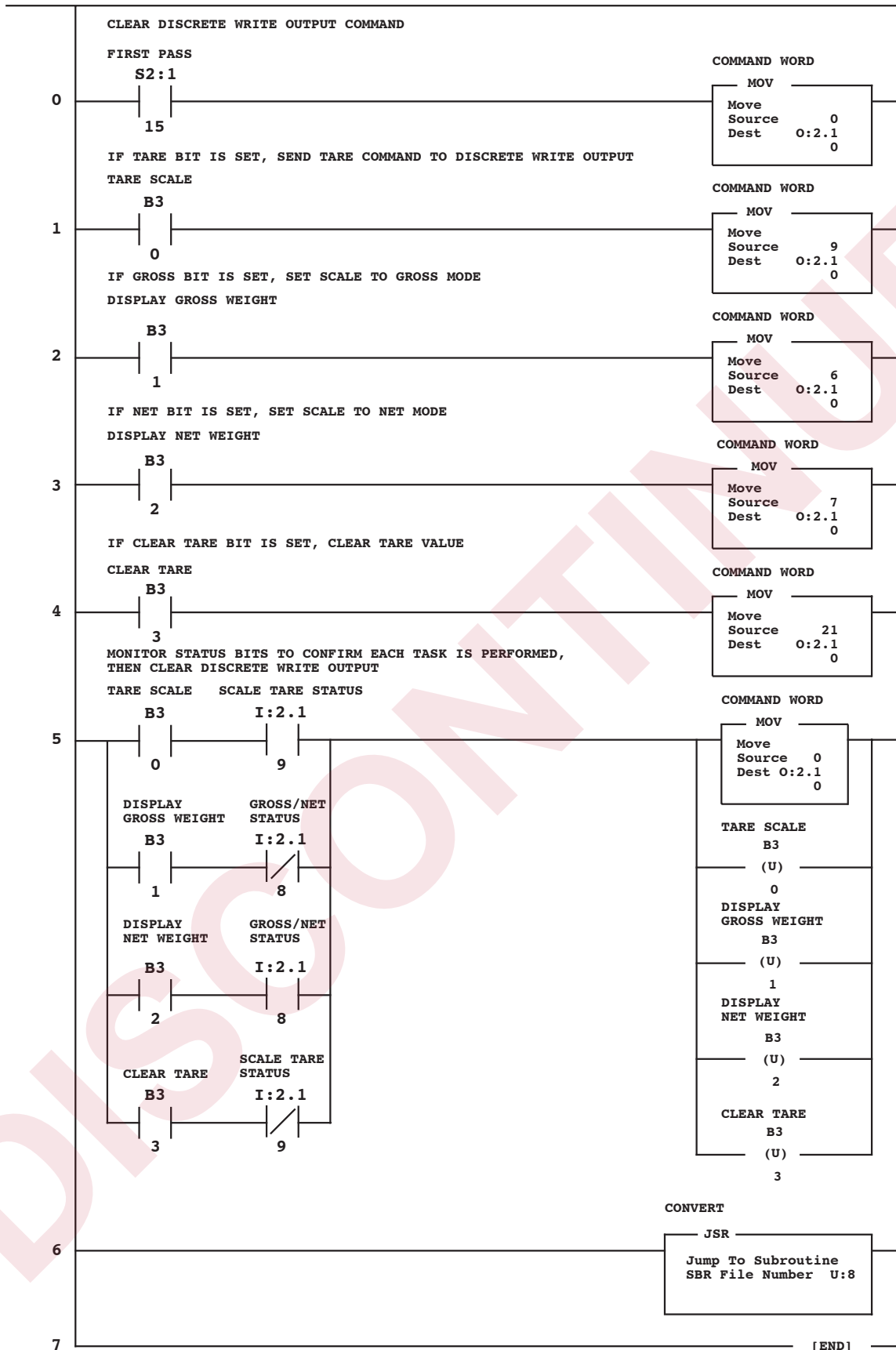

5.2 PLC Program for Converting 20-bit Values to Floating Integers

The following programming example converts a 20-bit value in the input image table to a floating integer value stored at location F8:5.

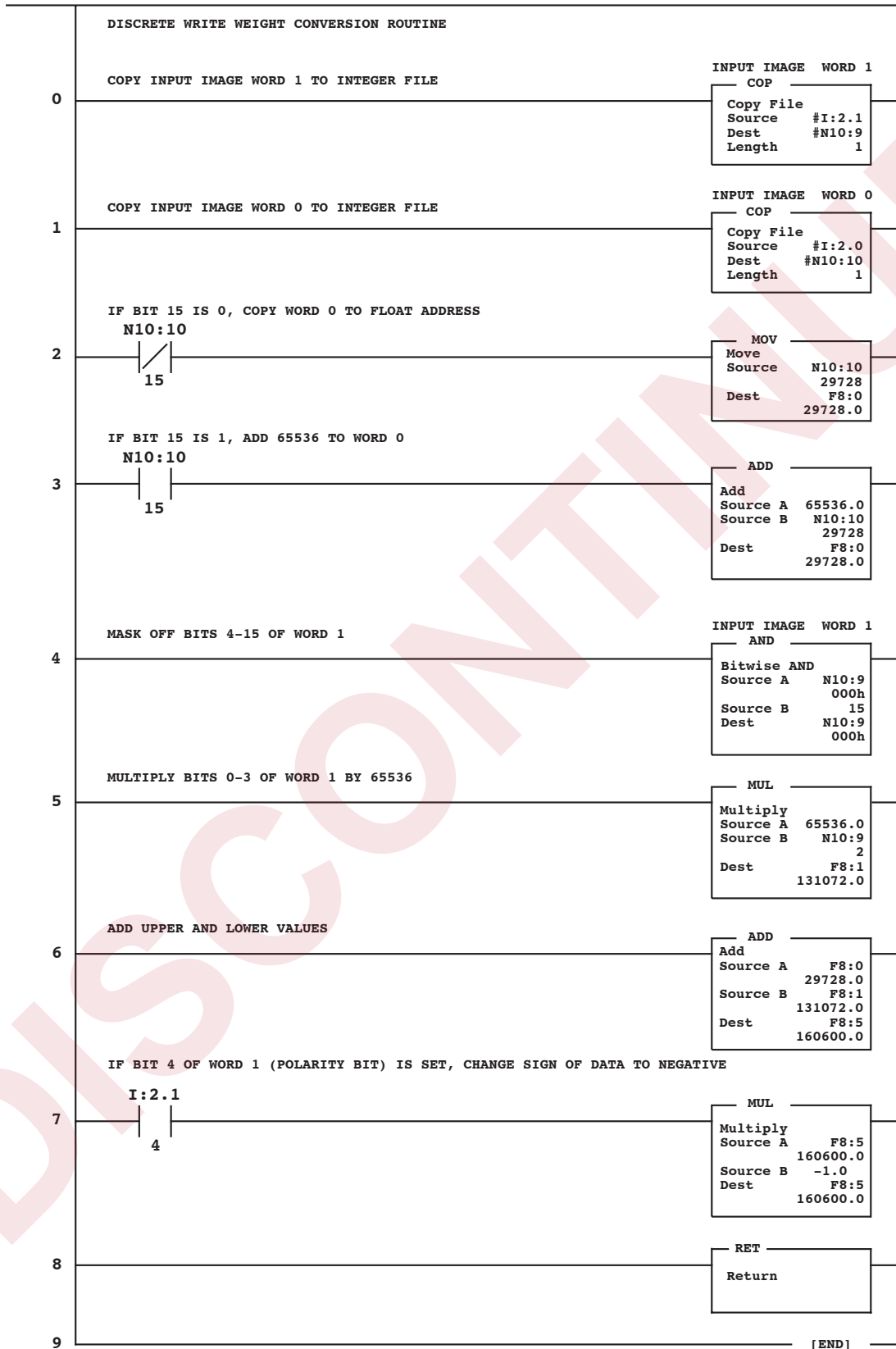

5.3 Using Block Transfer to Set and Read Setpoint Values

The following program example uses block transfer commands to write setpoint values to the IQ plus 800/810 indicator (block write/block read command 2), then read the values for the setpoint (block write/block read command 3). See Sections 4.2 and 4.3 for detailed descriptions of the Set and Read Setpoint Values block transfer commands.

NOTE: Setpoint values must be stored in float registers, then copied to the two integer words that correspond to that setpoint. See rungs 0–3 in the example shown on page 39.

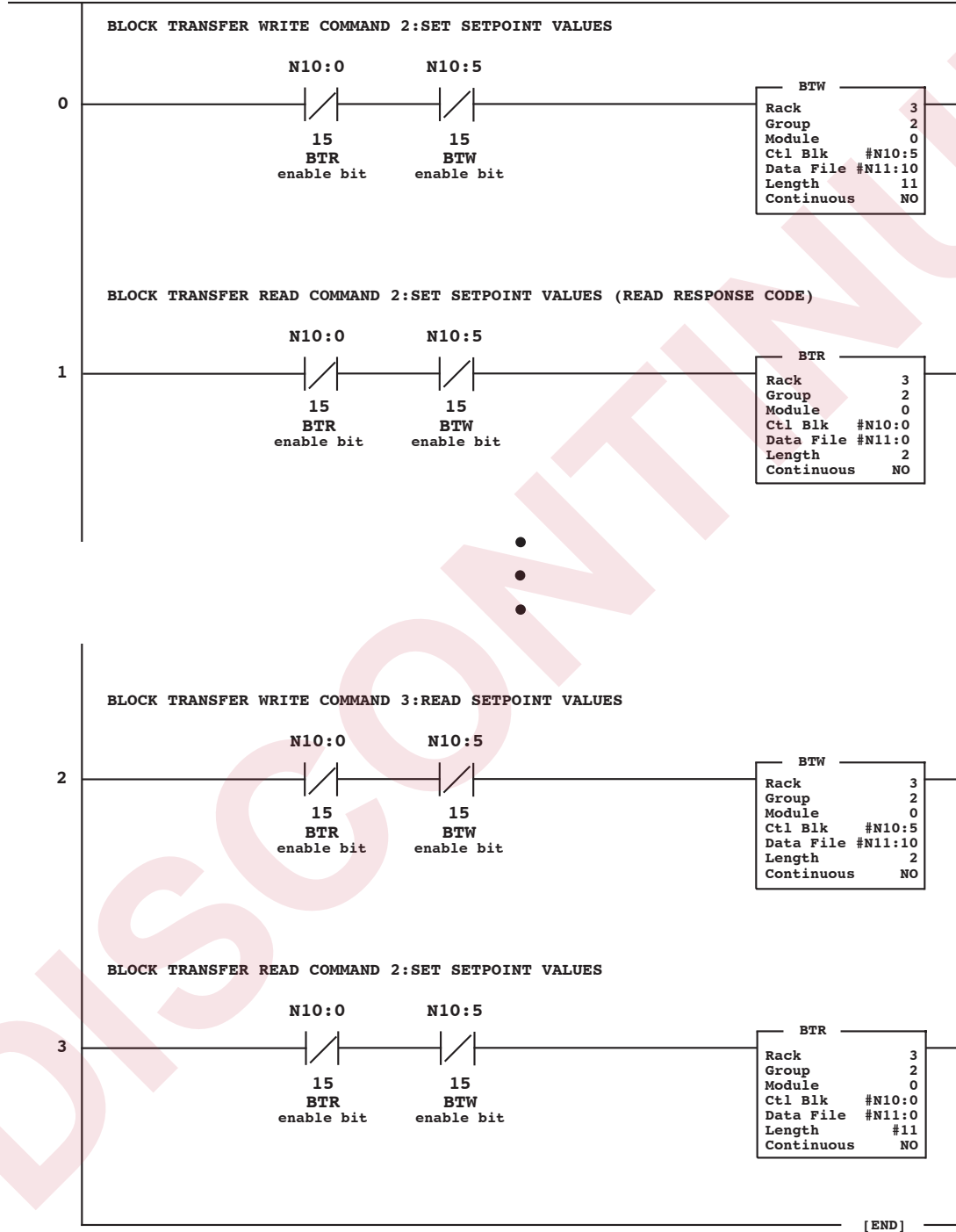

Floating point values used for the Set Setpoint Values parameters must be copied into separate words before issuing the command. Values returned on the Read Setpoint Values block read command must be converted back to floating point values. The following example shows these conversions for all four parameters on the Set and Read Setpoint Values commands.



5.4 Acquiring a Tare Value

The following example acquires a tare value. A timer is used to notify the operator if the tare has not been acquired within the time specified by the timer.

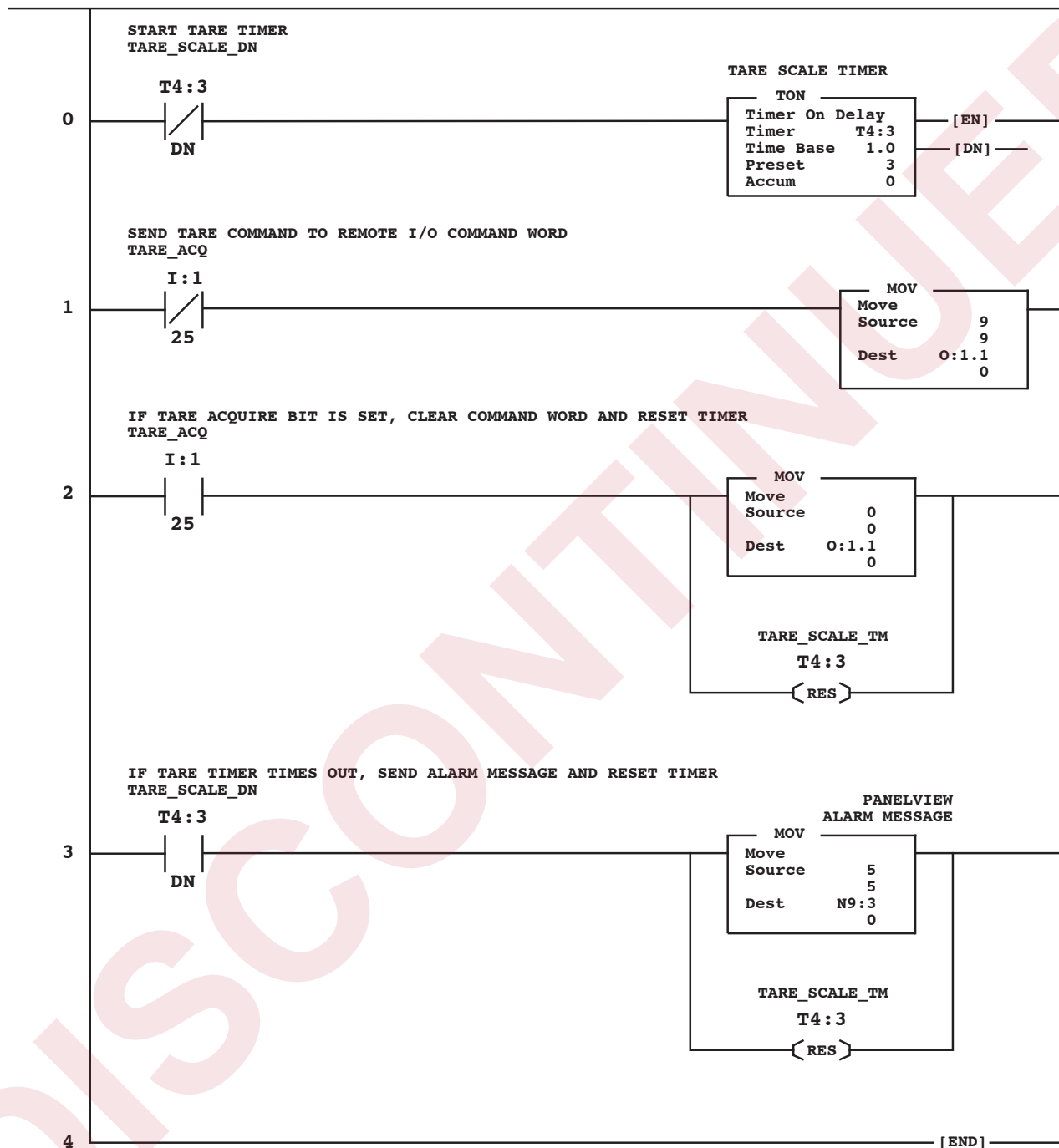

5.5 Reading Weights from Multiple Scale Channels

The following programming example uses a timer and the channel status bit (s02) to read net weights from two scale channels.

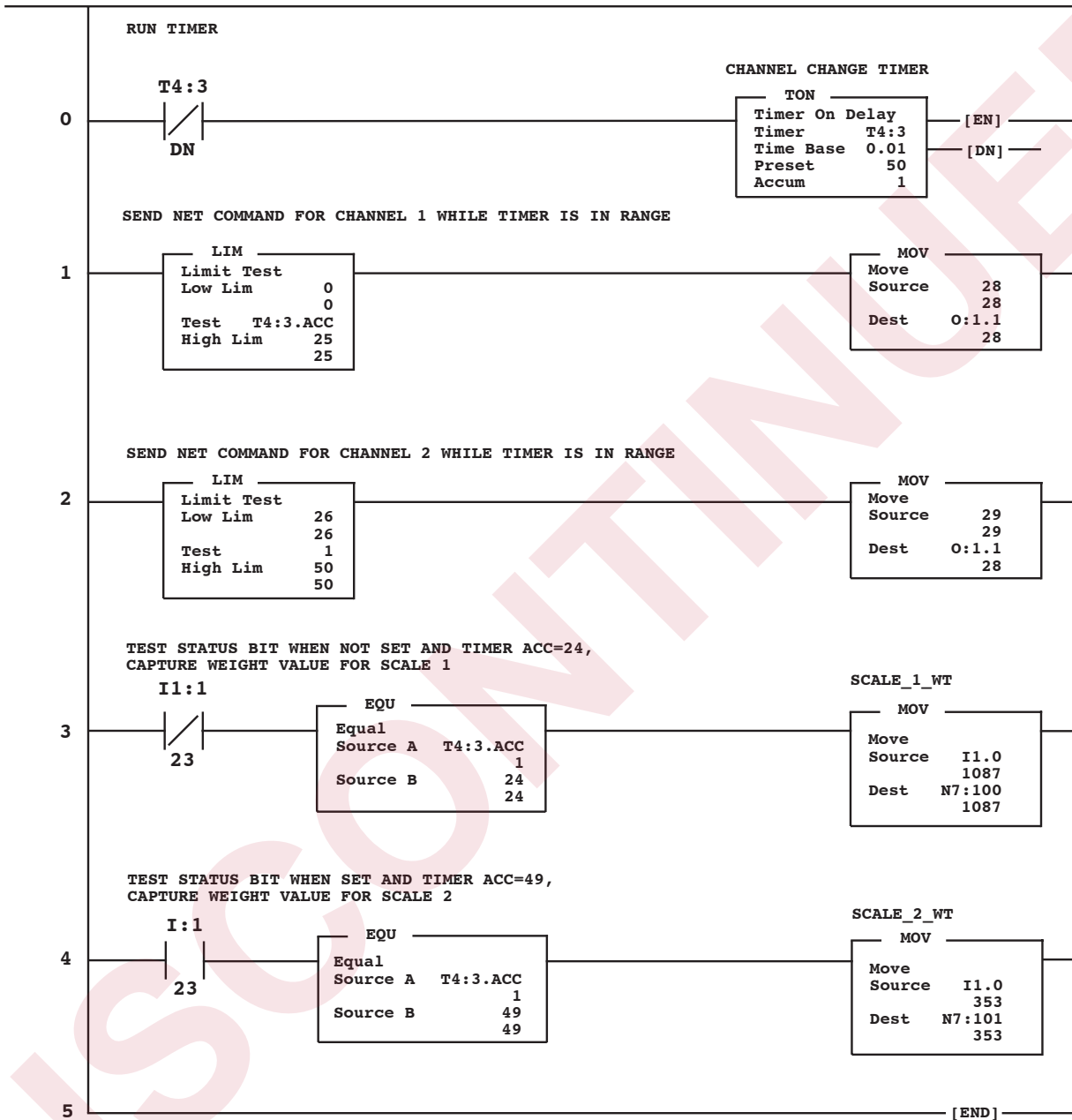

6.0 Troubleshooting

The LED indicators on the Remote I/O Interface can be used to isolate hardware and configuration problems. The LEDs show whether the problem exists in the connection to the indicator, the connection to the PLC controller, or the Remote I/O Interface itself.

The flowchart on the following page provides a diagnostic procedure for troubleshooting the Remote I/O Interface using the unit's LED indicators.

If all LEDs appear to be responding correctly, edit the program shown in Section 5.1 on page 35 for your installation and use it to test the Remote I/O Interface.

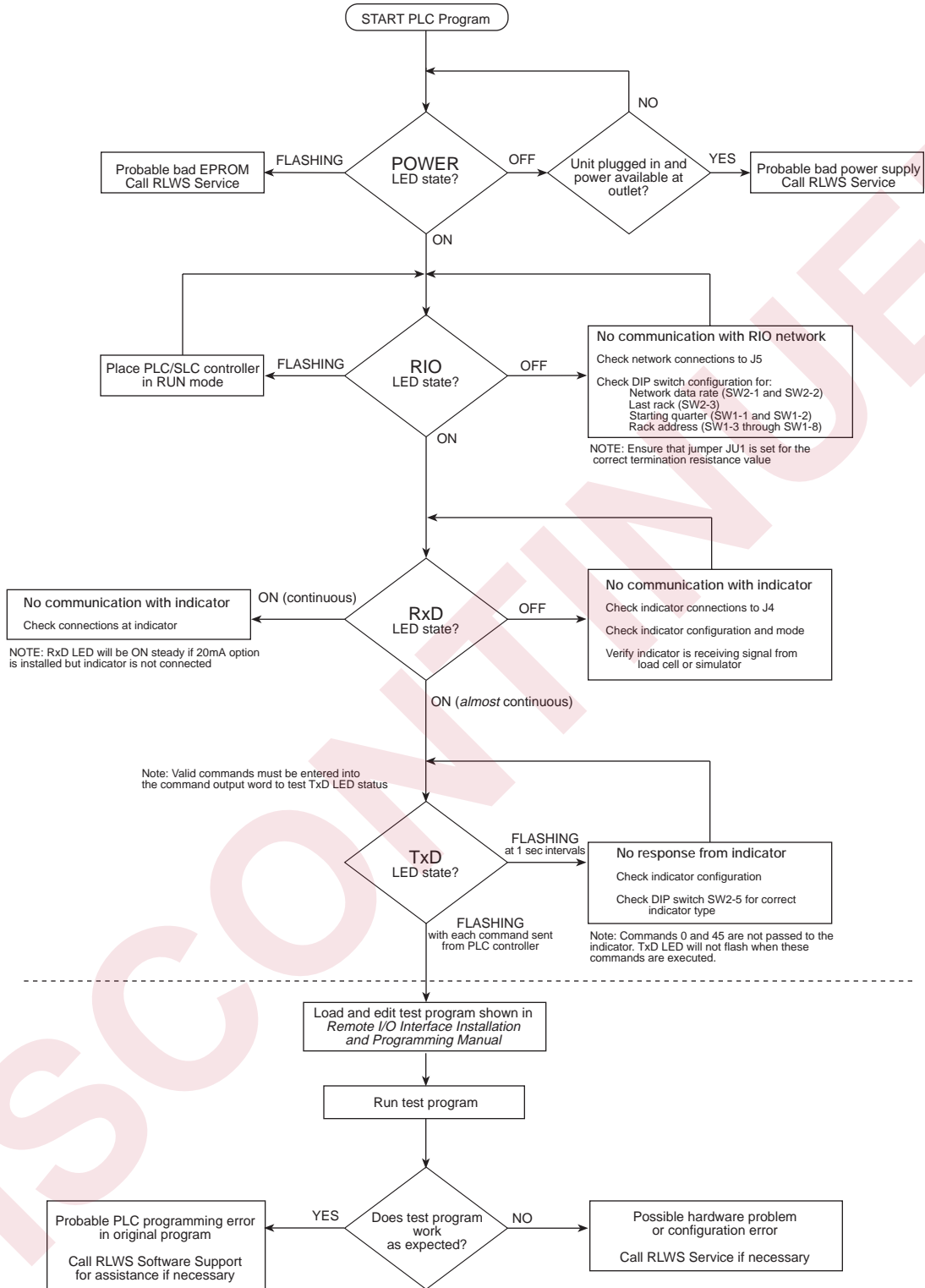

7.0 Power Supply Board

Two circumstances may require servicing the power supply board in the field:

- Power supply fuse replacement
- Conversion from 115 to 230 (or 230 to 115) VAC operation

Both operations require opening the enclosure and removing the logic board to access the power supply board. Figure 7-1 shows the layout of the power supply board, including the locations of the power supply fuses (F1 and F2) and the jumpers used to select operating voltage (JU1–JU3).

7.1 Fuse Replacement

Use the following procedure to replace fuses on the Remote I/O Interface power supply board:

1. Disconnect Remote I/O Interface from power source.



Caution

Use a wrist strap to ground yourself and protect components from electrostatic discharge (ESD) when working inside the Remote I/O Interface enclosure.

2. Remove enclosure cover.
3. Disconnect cables at J1 and J3 on the logic board (see Figure 2-2 on page 2).
4. Disconnect indicator and A-B network connections at J4 and J5 (see Figure 2-2).
5. Remove nuts from stand-offs in logic board corners, then lift logic board out of enclosure.
6. Remove blown fuses from fuse sockets. Replace with fuses as specified in Section 8.0.
7. Replace circuit board, reinstall nuts on board stand-offs.
8. Reconnect cables at J1 and J3.
9. Reconnect indicator and A-B network connections at J4 and J5 (see Section 2.1.2 on page 3).
10. Replace enclosure cover and tighten screws using torquing pattern shown in Figure 2-1 on page 2.
11. Reconnect power to the Remote I/O Interface.

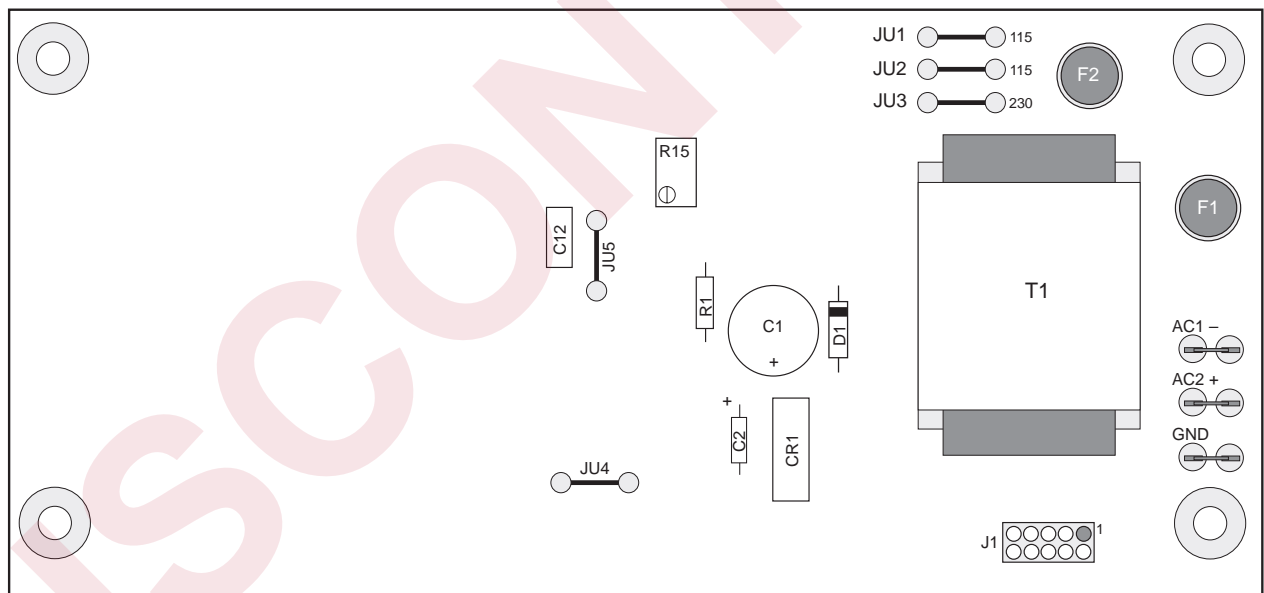

Figure 7-1. Remote I/O Power Supply Board

7.2 Operating Voltage Conversion

The Remote I/O Interface is normally set up for either 115 or 230 VAC operation before it is shipped. If the unit must be converted to a different operating voltage in the field, do the following:

1. Follow steps 1–5 of the fuse replacement procedure (Section 7.1 on page 44) to open the enclosure and remove the logic board.
2. Remove four 1.5-in. stand-offs from each corner of the power supply board.
3. Disconnect AC power connections on power supply board (AC+, AC–, and GND in Figure 7-1 on page 44), then lift board out of enclosure.
4. Change the jumper configuration for the new operating voltage. Figure 7-2 shows the jumper configurations for 115 and 230 VAC operation.

When converting from 115 to 230 VAC operation, clip jumpers JU1 and JU2 close to the pad, then solder one of the jumper wires across JU3. If converting to 115 VAC, or if new jumper wire must be used, use tinned AWG #22 wire for the jumpers. Ensure newly installed jumper wire does not extend below the power supply board.

5. Remove old fuses. Install fuses specified for the new operating voltage (see Section 8.0).
6. Replace power supply board and reconnect AC power connections.
7. Reinstall stand-offs.
8. Continue with steps 7–11 of the fuse replacement procedure to reinstall logic board and reconnect the Remote I/O Interface.

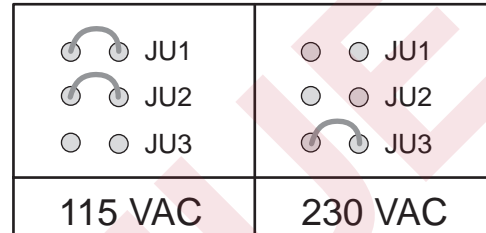

Figure 7-2. Jumper Configuration for 115 and 230 VAC Operation

8.0 Remote I/O Interface Specifications

Electrical Specifications

Voltage: 115 or 230 VAC (-10%/+15%)
 Frequency: 50 or 60 Hz
 Fusing: Two fast-acting 250 mA @ 250V subminiature fuses for 115 VAC operation
 Two fast-acting 125 mA @ 250V subminiature fuses for 230 VAC operation

Communications Specifications

Allen-Bradley Remote I/O Network Communications:
 Twinaxial cable attachment to networks at 56.6, 115.2, or 230.4 Kbps
 Serial Communications:
 Interface: RS-232C, 20mA current loop (optional)
 Data rate: 9600 or 19.2 Kbps
 ASCII encoding: 1 start bit, 8 data bits, 1 stop bit

Update Rates:

IO plus 310A: 40 updates/sec
 IO plus 800/810: 20 updates/sec
 IO plus 800/810 with JetPak: 32 updates/sec
 IO plus 800/810 multi-scale apps: 5-10 updates/sec

Environmental Specifications

Temperature: -10° to +40° C (14° to 104° F)

Dimensions

See diagrams below:

A: 4.88" (123.9 mm)
 B: 9.88" (250.9 mm)
 C: 3.13" (79.5 mm)
 D: 1.19" (30.2 mm)
 E: 3.70" (93.9 mm)

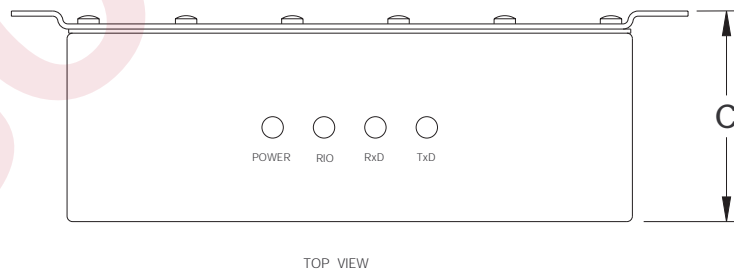
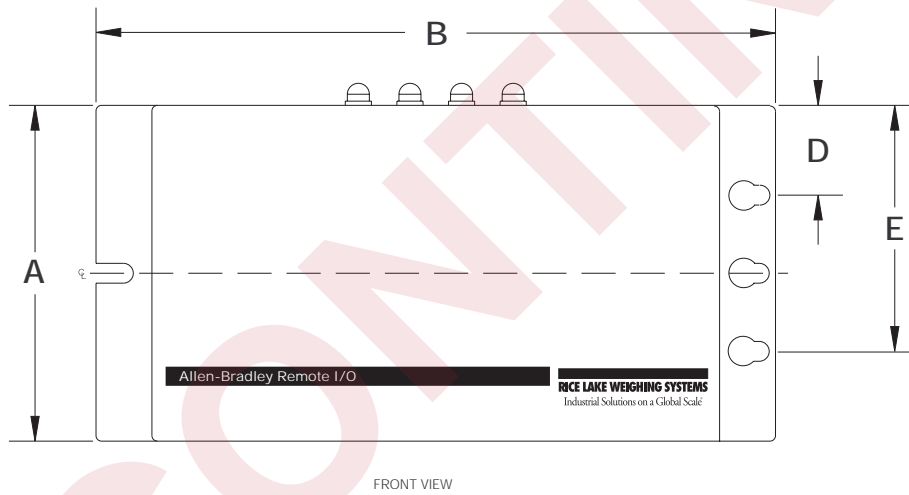

Remote I/O Interface Limited Warranty

Rice Lake Weighing Systems (RLWS) warrants that all RLWS equipment and systems properly installed by a Distributor or Original Equipment Manufacturer (OEM) will operate per written specifications as confirmed by the Distributor/OEM and accepted by RLWS. All systems and components are warranted against defects in materials and workmanship for one year.

RLWS warrants that the equipment sold hereunder will conform to the current written specifications authorized by RLWS. RLWS warrants the equipment against faulty workmanship and defective materials. If any equipment fails to conform to these warranties, RLWS will, at its option, repair or replace such goods returned within the warranty period subject to the following conditions:

- Upon discovery by Buyer of such nonconformity, RLWS will be given prompt written notice with a detailed explanation of the alleged deficiencies.
- Individual electronic components returned to RLWS for warranty purposes must be packaged to prevent electrostatic discharge (ESD) damage in shipment. Packaging requirements are listed in a publication, "Protecting Your Components From Static Damage in Shipment," available from RLWS Equipment Return Department.
- Examination of such equipment by RLWS confirms that the nonconformity actually exists, and was not caused by accident, misuse, neglect, alteration, improper installation, improper repair or improper testing; RLWS shall be the sole judge of all alleged non-conformities.
- Such equipment has not been modified, altered, or changed by any person other than RLWS or its duly authorized repair agents.
- RLWS will have a reasonable time to repair or replace the defective equipment. Buyer is responsible for shipping charges both ways.
- In no event will RLWS be responsible for travel time or on-location repairs, including assembly or disassembly of equipment, nor will RLWS be liable for the cost of any repairs made by others.

THESE WARRANTIES EXCLUDE ALL OTHER WARRANTIES , EXPRESSED OR IMPLIED , INCLUDING WITHOUT LIMITATION WARRANTIES OF MERCHANTABILITY OR FITNESS FOR A PARTICULAR PURPOSE . NEITHER RLWS NOR DISTRIBUTOR WILL , IN ANY EVENT , BE LIABLE FOR INCIDENTAL OR CONSEQUENTIAL DAMAGES .

RLWS AND BUYER AGREE THAT RLWS'S SOLE AND EXCLUSIVE LIABILITY HEREUNDER IS LIMITED TO REPAIR OR REPLACEMENT OF SUCH GOODS . IN ACCEPTING THIS WARRANTY , THE BUYER WAIVES ANY AND ALL OTHER CLAIMS TO WARRANTY .

SHOULD THE SELLER BE OTHER THAN RLWS, THE BUYER AGREES TO LOOK ONLY TO THE SELLER FOR WARRANTY CLAIMS .

NO TERMS , CONDITIONS , UNDERSTANDING , OR AGREEMENTS PURPORTING TO MODIFY THE TERMS OF THIS WARRANTY SHALL HAVE ANY LEGAL EFFECT UNLESS MADE IN WRITING AND SIGNED BY A CORPORATE OFFICER OF RLWS AND THE BUYER .

© 2000 Rice Lake Weighing Systems, Inc. Rice Lake, WI USA. All Rights Reserved.

RICE LAKE WEIGHING SYSTEMS • 230 WEST COLEMAN STREET • RICE LAKE, WISCONSIN 54868 • USA