

Batching Switch Option

The Batching Switch Option comes as a complete unit with legend plate, locking stop button, and run/start/abort 3-way switch. For SS and HE models, the unit can be mounted directly on the face of the case by drilling 7/8" holes for the two switches. Desktop models have insufficient room for switches on the case; a special FRP case is available for mounting the switch unit remotely. The remote mounting kit includes case, 5 feet of 18 gauge cable, nylon ring, and cord grip for sealing the cable connection to the indicator. Either mounting method is waterproof and maintains a NEMA 4X rating.

Both switches are wired into the indicator's digital I/O terminal strip as shown in the wiring diagram below. Each switch uses a separate digital input, leaving the third digital input available for other use.

After the switches are mounted and wired, the indicator must be configured for the correct digital input functions. Configuration instructions are found on the following page.

The following items describe the operation of the batching switch for indicators running Release 3.0 and Release 3.11 software:

- When correctly configured (see **WARNING** on the following page) the red STOP button must be in the OUT position to allow the batch process to run. To begin a batch process, the 3-way switch is momentarily turned to START. If the STOP button is pushed during the batch process, the process halts and the button locks in the IN position. The 3-way switch is ignored while the STOP button is locked in the IN position: The STOP button must be turned counterclockwise to unlock it, then released into the OUT position to enable the 3-way switch.
- To restart an interrupted batch from the step where it left off, do the following:
 1. Unlock STOP button (OUT position)
 2. Turn 3-way switch to START

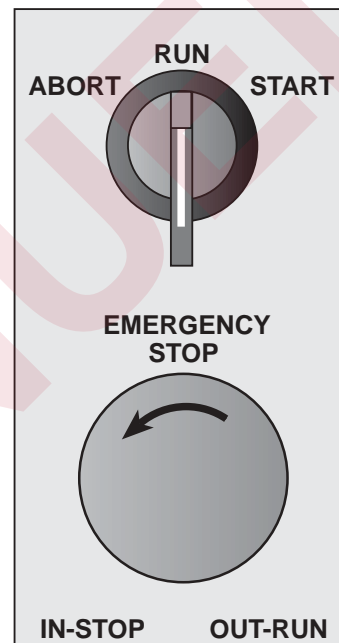

Caution

For indicators using Release 3.0 software, if a power failure occurs during a batch sequence, the sequence must be reset and restarted from the first batch step using the procedure below. You cannot resume the batch from the point of the power failure.

- To restart an interrupted batch from the first batch step, do the following:
 1. Turn 3-way switch to ABORT
 2. Unlock STOP button (OUT position)
 3. Turn 3-way switch to START

NOTE: Anytime setpoint configuration is changed, the batch sequence must be reset as described above to initialize the new batch routine.

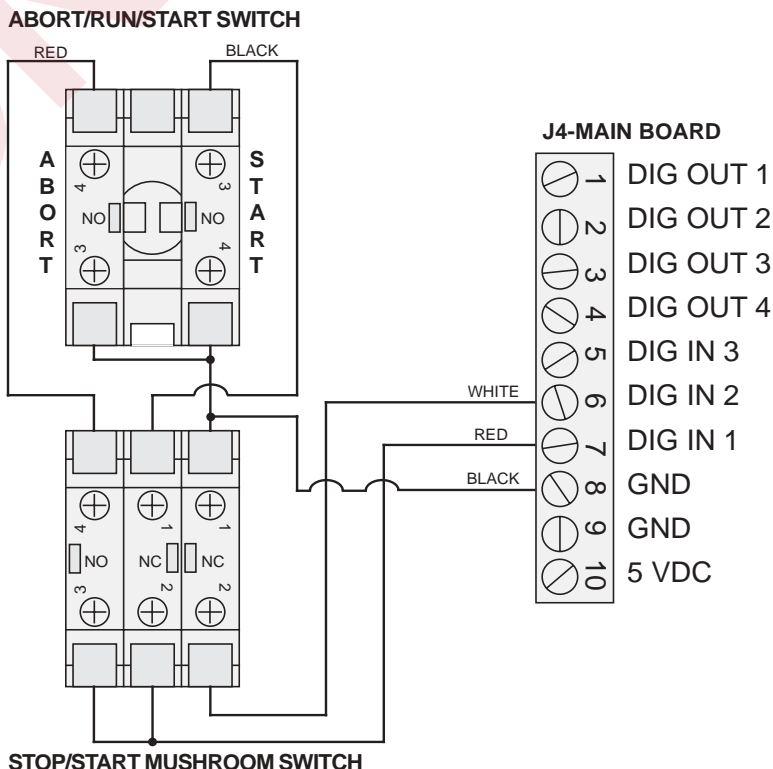

IQ plus® 800/810 Digital Weight Indicators **Batching Switch Option**

Configuring the Batching Switch Option

Once cables and switches have been connected to the indicator, use the setup switch to place the indicator in setup mode.

- For indicators using Release 3.0 software, go to the DIG IN menu, move to DIGIN 1 and select BATSTRT as digital input 1. Then move to DIGIN 2 and select BATRUN as digital input 2. See menu structure diagram below.
- For indicators using Release 3.11, the default values for DIGIN 1 and DIGIN 2 are BATSTRT and BATRUN, respectively. Use the procedure described above to verify the digital input assignments.



Warning

In Release 3.11, if no digital input is assigned to BATRUN, batching proceeds as if BATRUN were always on: If DIGIN 2 is not assigned to BATRUN, the batch will start when the 3-way switch is turned to RUN, but the STOP mushroom button will not function.

When configuration is complete, use the setup switch to place the indicator back in weighing mode. Initialize the batch by turning the 3-way switch to ABORT, then unlock the STOP button. The batching switch is now ready to use.

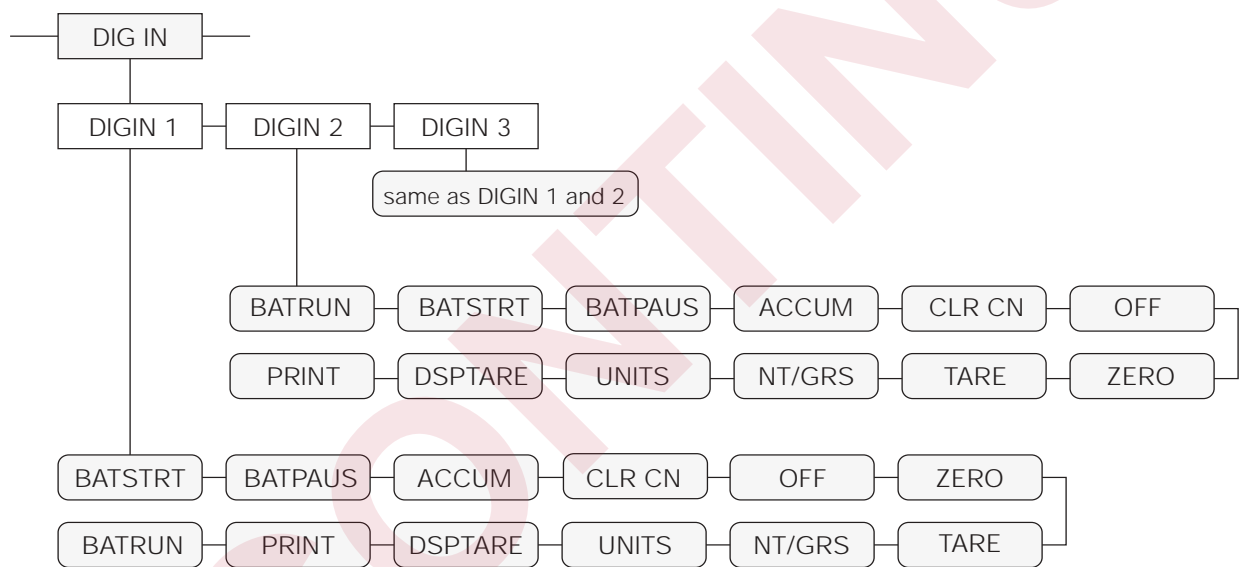

IQ plus 800/810 DIGIN Menu. In Release 3.0, the default value for DIGINs 1 and 2 is OFF; in Release 3.1, the default values are BATSTRT (DIGIN 1) and BATRUN (DIGIN 2). Always verify the digital input assignments before using the batching switch.