

UNI-10

3rd Edition

User Manual



© Rice Lake Weighing Systems. All rights reserved.

Rice Lake Weighing Systems® is a registered trademark of
Rice Lake Weighing Systems.

All other brand or product names within this publication are trademarks or
registered trademarks of their respective companies.



All information contained within this publication is, to the best of our knowledge, complete and
accurate at the time of publication. Rice Lake Weighing Systems reserves the right to make
changes to the technology, features, specifications and design of the equipment without notice.

The most current version of this publication, software, firmware and all other product
updates can be found on our website:

www.ricelake.com

This machine is manufactured for use according to proper procedures by a qualified person and only for the purposes described in this manual. The following conventions are used to indicate and classify precautions depending on the level of danger, or seriousness of potential injury. Always heed the information provided in this manual. Failure to heed precautions can result in personal injury or property damage.

The following precaution symbols are used in this manual.

 WARNING	Indicates a potentially hazardous situation which, if not avoided, may result in serious injury or death. Additionally, there may be significant property damage.
 CAUTION	Indicates a potentially hazardous situation where, if not avoided, may result in minor or moderate injury or in property damage.

NOTICES

IMPORTANT NOTICE

Those who handle the machine must be aware of the hazards involved. These dangers may not be obvious, so it is imperative to follow the instructions detailed in this manual and the manual enclosed in CD when installing, operating, inspecting, or servicing the machine. Therefore, we recommend that you thoroughly read and understand these manuals before installing, operating, inspecting, or servicing the machine. ISHIDA is not liable for any damage, loss or injury that results from incorrect operation, insufficient caution, unauthorized modifications to the machine, or failure to follow the instructions contained in these manuals.

LIMITATIONS OF LIABILITY

ISHIDA assumes no responsibility for special, indirect, or consequential damages, loss of profits or commercial loss in any way connected with the machine, whether such claim is based on contract, warranty, negligence, or strict liability.

ISHIDA assumes no responsibility for the user's programming of this machine, or any consequence thereof. In no event shall ISHIDA be responsible for warranty, repair, or other claims regarding the machine unless ISHIDA's analysis confirms that the machines were properly handled, stored, installed, and maintained and not subject to contamination, abuse, misuse, or inappropriate modification or repair.

CHANGE IN SPECIFICATIONS

Machine specifications and accessories may be changed at any time due to improvements or other reasons. Consult with your ISHIDA representative at any time to confirm the actual specifications of the purchased machine.

ERRORS AND OMISSIONS

The information in this manual has been carefully checked and is believed to be accurate; however, no responsibility is assumed for clerical, typographical or proofreading errors, or omissions.

PRECAUTIONS FOR SAFE USE

It is strongly advised that the following safety measures must be observed to ensure the safe operation of the machine.

IMPORTANT

- Read this manual and the manual enclosed in CD thoroughly, and do not perform installation, operation, maintenance, or inspection unless you fully understand all of the contents.
- Keep this manual and the manual enclosed in CD in a safe place where you can refer to it easily while installing, operating, and carrying out maintenance or inspections.



WARNING

- This product is a commercial scale which is not intended for use by children. It is not suitable for use in locations where children are likely to be present.
- Prepare a dedicated power source and always use a power supply with rated voltage. Never connect the machine power input with an AC power supply exceeding the rated voltage. To avoid any potential electrical shock, ensure that the protective ground wire is connected to the main grounding provision.
- A power supply that generates voltage variation may cause a malfunction, or using the machine outside of the rated voltage may result in machine failure or danger such as electric shock.
- The equipment disconnect device is considered to be: Appliance inlet.
- For telecommunication type connectors and terminals not used for connection to the telecommunication network. It should be intended to be used for Cash Drawer.
- Replacement of fuses is limited only by service personnel. Service personnel should refer to service documentation for instructions for the replacement.
- Replacement of Battery is limited only by service personnel.
- This product contains a battery. During using, storing, or transporting this product, do not place it in extremely hot or cold places, or at high altitude and low atmospheric pressure.
- Don't disposal of battery into fire or a hot oven.
- Don't leave the product including a battery in an extremely high temperature surrounding environment or the leakage of flammable liquid or gas.
 - * To Service personnel:
Risk of Explosion if Battery is replaced by an Incorrect Type. Dispose of Used Batteries According to the Instructions.
- Ce produit est une balance commerciale qui n'est pas destinée à être utilisée par des enfants. Il ne convient pas pour une utilisation dans des endroits où des enfants sont susceptibles d'être présents.
- Ce produit est à l'échelle commerciale et n'est pas destiné aux enfants.
- Utiliser une source d'alimentation dédié avec la tension recommandée. Ne raccordez jamais la balance avec une alimentation CA dépassant la tension recommandée. Pour éviter tout choc électrique, assurez-vous que le fil de la mise à la terre est raccordé au dispositif de la mise à la terre.
- Une alimentation qui génère une variation de tension peut occasionner un bris de la balance, ou connecter la balance avec une tension nominale hors norme peut entraîner une défaillance de la balance ou provoquer un choc électrique.
- Le dispositif de déconnexion de l'équipement doit être fiche à *la prise* de la balance.
- Les connecteurs pour la télécommunication servent pour la connexion au réseau de télécommunication. Tous les autres terminaux servent pour connecter le tiroir-caisse.
- Le remplacement des fusibles ne doit être exécuté que par un technicien qualifié. Le technicien doit se référer à la documentation technique pour le remplacement.
- Le remplacement de la batterie rechargeable doit être exécuté par un technicien qualifié.
- Ce produit contient une batterie. Lors de l'utilisation, du stockage ou du transport de ce produit, ne le placez pas dans des endroits extrêmement chauds ou froids, ou à haute altitude et à basse pression atmosphérique.
- Ne jetez pas la batterie au feu ou dans un four chaud.
- Ne laissez pas le produit, y compris une batterie, dans un environnement environnant à température extrêmement élevée ou en cas de fuite de liquide ou de gaz inflammable.
 - * Note : importante au technicien :
Risque d'explosion si la batterie est remplacée par une batterie avec d'autres spécifications.

WARNING

- **Prepare a dedicated power source and always use a power supply with rated voltage. Never connect the machine power input with an AC power supply exceeding the rated voltage. To avoid any potential electrical shock, ensure that the protective ground wire is connected to the main grounding provision.**

A power supply that generates voltage variation may cause a malfunction, or using the machine outside of the rated voltage may result in machine failure or danger such as electric shock.

- **Do not install the machine near a TV set or radio.**

Doing so may cause static to the TV set and/or radio as this machine emits weak electric wave.

- **Do not allow water or any liquids to come into contact with the machine.**

Doing so may result in fire or cause the machine to break down.

- **Do not drop or apply a strong shock to the machine.**

Doing so may cause the machine to break down.

- **Do not disassemble, modify, or attempt to repair the machine.**

Doing so may damage the original safety functions.

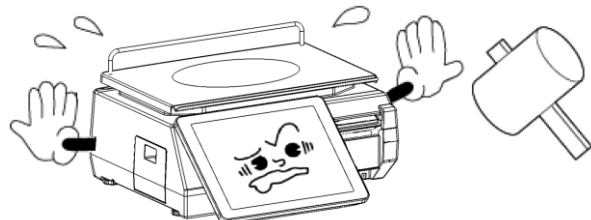
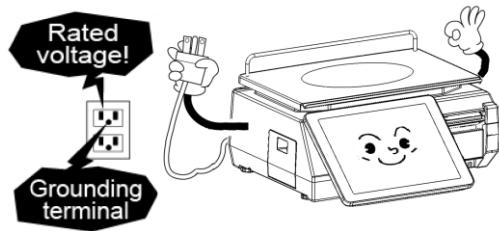

WARNING

- **Do not hold the connector cover when carrying the machine.**

Dropping the machine may result in injury or cause the machine to break down.

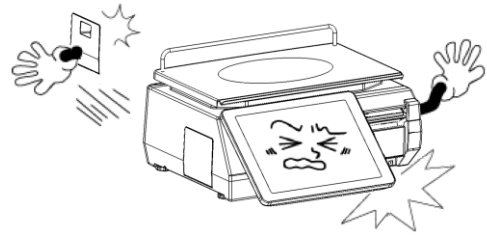

- **Do not hold the operation panel or weigh platter when carrying the machine.**

Doing so may cause the operation panel or the platter to break down.



- **Do not hold the pole type display when carrying the machine.**

Dropping the machine may result in injury or cause the machine to break down.

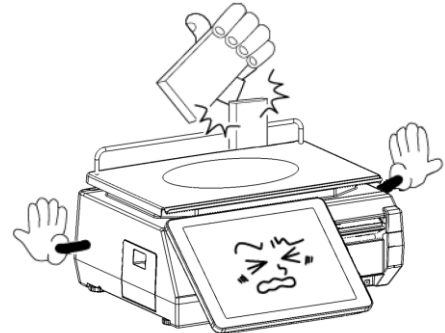

- **Handle with care when removing or inserting the cassette.**

Careless cassette handling may result in injury or cause the cassette to break down.

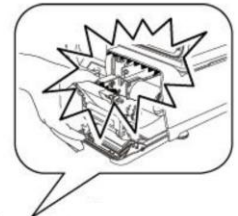

- **Do not drop the cassette.**

Dropping the cassette may result in injury or cause the cassette to break down.

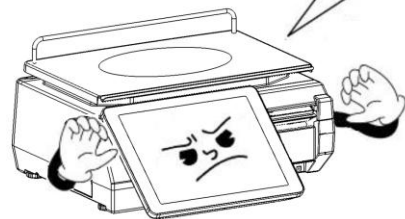

- **Do not press the touch panel with an edged thing.**

Doing so may scratch the panel and cause the machine to break down.

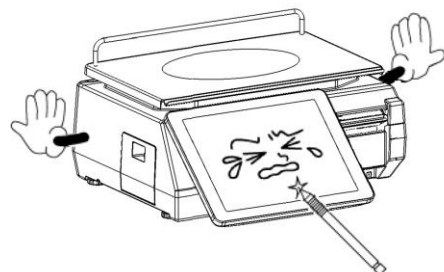

⚠ WARNING

- Risk of explosion if battery is replaced by an incorrect type. Make sure to dispose of used batteries according to the instructions.

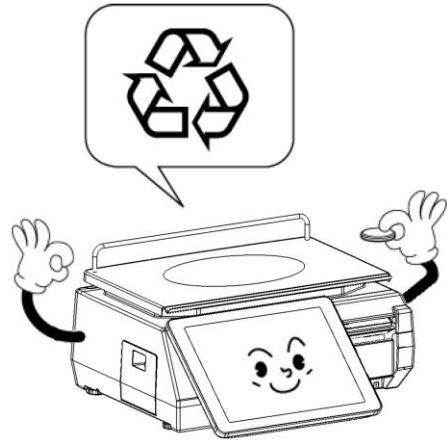

PRECAUTION REGARDING FCC RULE IN USA

Note: This equipment has been tested and found to comply with the limits for a Class A digital device, pursuant to part 15 of the FCC Rules. These limits are designed to provide reasonable protection against harmful interference when the equipment is operated in a commercial environment. This equipment generates, uses, and can radiate radio frequency energy and, if not installed and used in accordance with the instruction manual, may cause harmful interference to radio communications. Operation of this equipment in a residential area is likely to cause harmful interference in which case the user will be required to correct the interference at his own expense.

PRECAUTION REGARDING WIRELESS MODULE

It is strongly advised that the following safety measures must be observed to ensure the safe operation of the machine in case that wireless module is installed.

-In Case that Wireless LAN / Wireless platter are equipped

For Europe

This model is a Non-automatic weighing instrument with price labeling. Wireless LAN module may be installed on purpose to connect to access point of 2.4GHz network. Also, Wireless module may be installed on purpose to connect between main control unit and weighing platter.



For Canada / USA

Changes or modifications not expressly approved by the party responsible for compliance could void the user's authority to operate the equipment.

This transmitter must not be co-located or operated in conjunction with any other antenna or transmitter. This equipment complies with FCC/IC radiation exposure limits set forth for a controlled environment and meets the FCC radio frequency (RF) Exposure Guidelines and RSS-102 of the IC radio frequency (RF) Exposure rules. This equipment should be installed and operated keeping the radiator at least 20cm or more away from person's body (excluding extremities: hands, wrists, feet and ankles).

Under Industry Canada regulations, this radio transmitter may only operate using an antenna of a type and maximum (or lesser) gain approved for the transmitter by Industry Canada. To reduce potential radio interference to other users, the antenna type and its gain should be so chosen that the equivalent isotropically radiated power (e.i.r.p.) is not more than that necessary for successful communication.

The W52/W53 are restricted to indoor operation only.

Cet équipement est conforme aux limites d'exposition aux rayonnements énoncées pour un environnement contrôlé et respecte les règles les radioélectriques (RF) de la FCC lignes directrices d'exposition et d'exposition aux fréquences radioélectriques (RF) CNR-102 de l'IC. Cet équipement doit être installé et utilisé en gardant une distance de 20 cm ou plus entre le dispositif rayonnant et le corps (à l'exception des extrémités : mains, poignets, pieds et chevilles).

Conformément à la réglementation d'Industrie Canada, le présent émetteur radio peut fonctionner avec une antenne d'un type et d'un gain maximal (ou inférieur) approuvé pour l'émetteur par Industrie Canada. Dans le but de réduire les risques de brouillage radioélectrique à l'intention des autres utilisateurs, il faut choisir le type d'antenne et son gain de sorte que la puissance isotrope rayonnée équivalente (p.i.r.e.) ne dépasse pas l'intensité nécessaire à l'établissement d'une communication satisfaisante.

Les bandes W52 et W53 sont limitées à une utilisation en intérieur uniquement.

PRECAUTIONS FOR MACHINE INSTALLATION

WARNING

Do not install the machine in the following types of places:

- Places subject to high temperatures or high humidity
- Places exposed to direct sunlight
- Places where water or other liquids are easily spilled on the machine
- Places subject to excessive vibration or unstable foundations
- Places exposed to direct cold air from air conditioners or refrigerators
- Places where the floor or foundation is unstable
- Places subject to a lot of dust or dirt
- Places with large voltage fluctuations

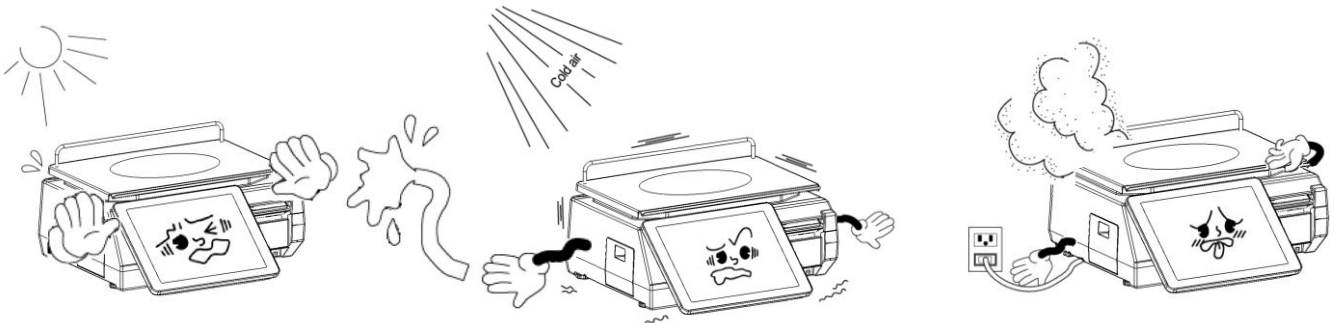

PRECAUTION SYMBOLS

This machine is manufactured for use according to proper procedures by a qualified person and only for the purposes described in this manual. The following conventions are used to indicate and classify precautions depending on the level of danger, or seriousness of potential injury. Always heed the information provided in this manual. Failure to heed precautions can result in personal injury or property damage.

The following precaution symbols are used in this manual.





 WARNING	Indicates a potentially hazardous situation which, if not avoided, may result in serious injury or death. Additionally, there may be significant property damage.
 CAUTION	Indicates a potentially hazardous situation where, if not avoided, may result in minor or moderate injury or in property damage.
 INFOR	Indicates reference information for operation.
 REFER	Indicates the referred page for operation.

TABLE OF CONTENTS

CHAPTER 1 BEFORE USE	1-1
1.1 SPECIFICATIONS	1-1
1.2 PART NAMES.....	1-3
1.3 LEVEL ADJUSTMENT	1-4
1.4 LABEL / RECEIPT ROLL LOADING	1-5
1.5 REMOVING & REPLACING OF WEIGHING PLATTER	1-7
1.5.1 REMOVING THE WEIGHING PLATTER	1-7
1.5.2 REPLACING THE WEIGHING PLATTER.....	1-7
1.6 CLEANING OF THE MACHINE	1-8
1.6.1 CLEANING OF THE THERMAL HEAD	1-8
1.6.2 CLEANING OF THE LABEL SENSOR	1-9
1.6.3 CLEANING OF THE PRINT ROLLER AND PRISM	1-10
1.6.4 PRECAUTIONS WHEN USING CLEANING FLUIDS	1-11
1.7 STARTING PROCEDURES.....	1-12
1.7.1 TURNING ON THE POWER.....	1-12
1.7.2 ZERO ADJUSTMENT	1-13
1.7.3 GETTING BACK TO THE INITIAL SCREEN.....	1-13
CHAPTER 2 OPERATION MODE	2-1
2.1 OPERATION MODE ENTRY / EXIT	2-1
2.2 SCREEN EXAMPLES FOR PRODUCT CATEGORIES	2-2
2.3 SALES OPERATIONS	2-4
2.3.1 ISSUING LABELS FOR WEIGHING PRODUCTS.....	2-4
2.3.2 ISSUING LABELS FOR WEIGHING FIXED PRICE PRODUCTS	2-6
2.3.3 ISSUING LABELS FOR FIXED PRICE PRODUCTS.....	2-8
2.3.4 ISSUING LABELS FOR FIXED WEIGHT/UNIT PRICE PRODUCTS.....	2-10
2.3.5 ISSUING LABELS REQUIRING OPERATOR REGISTRATION	2-12
2.3.6 ENTERING OR OVERWRITING TARE WEIGHTS	2-14
2.3.7 CHANGING UNIT PRICES	2-14
2.3.8 CHANGING FIXED PRICES.....	2-15
2.3.9 DISCOUNTING UNIT PRICES BY AMOUNT.....	2-15
2.3.10 DISCOUNTING UNIT PRICES BY PERCENTAGE	2-16
2.3.11 DISCOUNTING TOTAL PRICES BY AMOUNT	2-16
2.3.12 DISCOUNTING TOTAL PRICES BY PERCENTAGE.....	2-17
2.3.13 CHANGING QUANTITIES	2-17
2.3.14 SPECIFYING THE NUMBER OF LABELS.....	2-18
2.3.15 SELF-SERVICE OPERATIONS FOR WEIGHING PRODUCTS.....	2-19
2.3.16 SELF-SERVICE OPERATIONS FOR FIXED PRICE PRODUCTS	2-20
2.3.17 ACCUMULATIONS THROUGH MANUAL ENTRY	2-21
2.3.18 ACCUMULATIONS THROUGH WEIGHING PRODUCTS.....	2-23
2.3.19 VOIDING REGISTRATIONS THROUGH MANUAL ENTRY.....	2-25





2.3.20 VOIDING THROUGH WEIGHING PRODUCTS.....	2-27
2.3.21 SUBTRACTING TOTALS THROUGH MANUAL ENTRY	2-29
2.3.22 SUBTRACTING TOTALS THROUGH WEIGHING PRODUCTS	2-31
2.3.23 ADDING TOTALS THROUGH MANUAL ENTRY	2-33
2.3.24 ADDING TOTALS THROUGH WEIGHING PRODUCTS	2-35
CHAPTER 3 TOTAL MODE	3-1
3.1 TOTAL MODE ENTRY / EXIT	3-1
3.2 DAILY TOTALS.....	3-2
3.3 WEEKLY TOTALS.....	3-5
3.4 CUMULATIVE TOTALS.....	3-6
3.5 TRACEABILITY TOTALS.....	3-8
3.6 PRESET REPORTS.....	3-9
3.7 TOTAL CLEAR	3-10
CHAPTER 4 PROGRAM MODE	4-1
4.1 PROGRAM MODE ENTRY / EXIT	4-1
4.2 PLU DATA	4-2
4.3 CAMPAIGN DATA	4-11
4.4 OPERATOR DATA.....	4-13
4.5 PRESET KEY REGISTRATION.....	4-15
4.5.1 SETTING PRESET GROUPS AND PAGES.....	4-15
4.5.2 SETTING PRESET KEYS.....	4-16
4.5.3 CHANGING PRESET KEY SIZES AND POSITIONS	4-18
4.5.4 EDITING PRESET KEYS.....	4-19
4.5.5 DELETING PRESET KEYS	4-24
4.6 ADVERTISEMENT MESSAGES	4-25
4.7 SCHEDULE DATA	4-29
4.8 STORE DATA.....	4-31
4.9 DEPARTMENT NAME DATA.....	4-34
4.10 GROUP NAME DATA.....	4-36
4.11 COOKING INSTRUCTION DATA.....	4-38
4.12 EXTRA MESSAGE DATA.....	4-40
4.13 COUPON MESSAGE DATA.....	4-42
4.14 POP MESSAGE DATA.....	4-44
4.15 SCHEME TABLE DATA.....	4-46
4.16 GEN TABLE DATA	4-50
4.17 LOOKUP TABLE DATA	4-52
4.18 MINCE TRACEABILITY DATA	4-55
4.19 FIXED PRICE SYMBOLS	4-56
4.20 FREE MESSAGE DATA.....	4-58

4.21	CHECK LABEL DATA.....	4-60
4.22	STAMP PRICE DATA.....	4-61
4.23	NUTRITION TEXT DATA.....	4-62
4.24	NUTRITION DATA	4-64
CHAPTER 5 SETUP MODE		5-1
5.1	SETUP MODE ENTRY / EXIT	5-1
5.2	MACHINE NUMBER / NETWORK NUMBER.....	5-2
5.3	SALES MODE	5-4
5.4	PASSWORD.....	5-5
5.5	KEY LOCK.....	5-8
5.6	DATA STORAGE	5-11
5.7	PRESET REPORT	5-12
5.8	PLU OVERWRITE	5-14
5.9	PLU INITIAL DATA	5-16
5.10	PLU UPDATE.....	5-25
5.11	RECEIPT SETTING	5-28
5.12	TAX REGISTRATION.....	5-30
CHAPTER 6 ADJUSTMENT MODE.....		6-1
6.1	ADJUSTMENT MODE ENTRY / EXIT	6-1
6.2	DATE / TIME.....	6-2
6.3	TOUCH SCREEN	6-4
6.4	DISPLAY CHECK	6-5
6.5	SOUND	6-6
APPENDIX TEXT EDITING.....		A-1
A.1	EDIT SCREENS	A-1
A.2	EDIT KEYS.....	A-2
A.3	INPUT EXAMPLES.....	A-4
A.3.1	TEXT EDITING	A-4
A.3.2	FONT STYLE SELECTION.....	A-5
A.3.3	LINE DATA DELETION	A-6
A.3.4	DATA ERASE	A-7
A.3.5	DATA COPY	A-8

BEFORE USE

1.1 SPECIFICATIONS

UNIT	ITEM	DESCRIPTIONS					
		12.1 inch			10.1 inch		
		UNI-10 B	UNI-10 P	UNI-10 H	UNI-10 B	UNI-10 P	UNI-10 H
Weighing unit	Weighing capacity	30 lb specification: 0 to 15 lb / 0.005 lb, 15 to 30 lb / 0.010 lb (15 kg specification: 0 to 6 kg / 2 g, 6 to 15 kg / 5 g)					
	Weighing accuracy	1/3000					
Operation panel unit	Display method	12.1 inch color TFT liquid crystal display with LED backlight, Screen resolution XGA (1024 X 768 dots)			10.1 inch color TFT liquid crystal display with LED backlight, Screen resolution WXGA (1280 X 800 dots)		
Customer display unit	Display method	7 inch color TFT liquid crystal display with LED backlight, Screen resolution WVGA (800 X 480 dots)					
Printer unit	Printing method	Direct thermal method					
	Thermal head	3 inches (960 dots) and 12 dots/mm					
	Printing speed	120 mm/second <i>Note: The printing speed may vary depending on the label conditions.</i>					
	Printing effective size	80 mm in width					
	Label roll size	Label width: 30 to 80 mm Label length: 20 to 100 mm					
Cassette unit	Label replacement No. of	Front loading cassette Up to 7 cassettes can be used. Roll outside diameter: □ 125 mm max. □ Paper core inside diameter: □ 40 mm □ 1 mm					
Others	Power supply	100 to 240 VAC, 50/60Hz, 1A / 0.5A					
	Use conditions	Temperature: -5 to 40°C Humidity: 20 to 85%, non-condensing.					
	Input / Output	LAN : 1 channel USB 2.0 : 4 channels Cash drawer : 1 channel					

UNI-10 B Type 12.1 inch	UNI-10 B Type 10.1 inch
 <p>A desktop scale with a large 12.1-inch touchscreen display. The screen shows a digital scale interface with a keypad and various function buttons. The scale has a flat weighing platform on top.</p>	 <p>A desktop scale with a 10.1-inch touchscreen display. The screen shows a digital scale interface. The scale has a flat weighing platform on top.</p>
UNI-10 H Type Front	UNI-10 H Type Rear
 <p>A hanging scale with a 12.1-inch touchscreen display. The screen shows a digital scale interface. The weighing pan is suspended below the main unit.</p>	 <p>A hanging scale with a 10.1-inch touchscreen display. The screen shows a digital scale interface. The weighing pan is suspended below the main unit. The display also shows the 'ISHIDA' logo and a product image.</p>

1.2 PART NAMES

DESCRIPTIONS

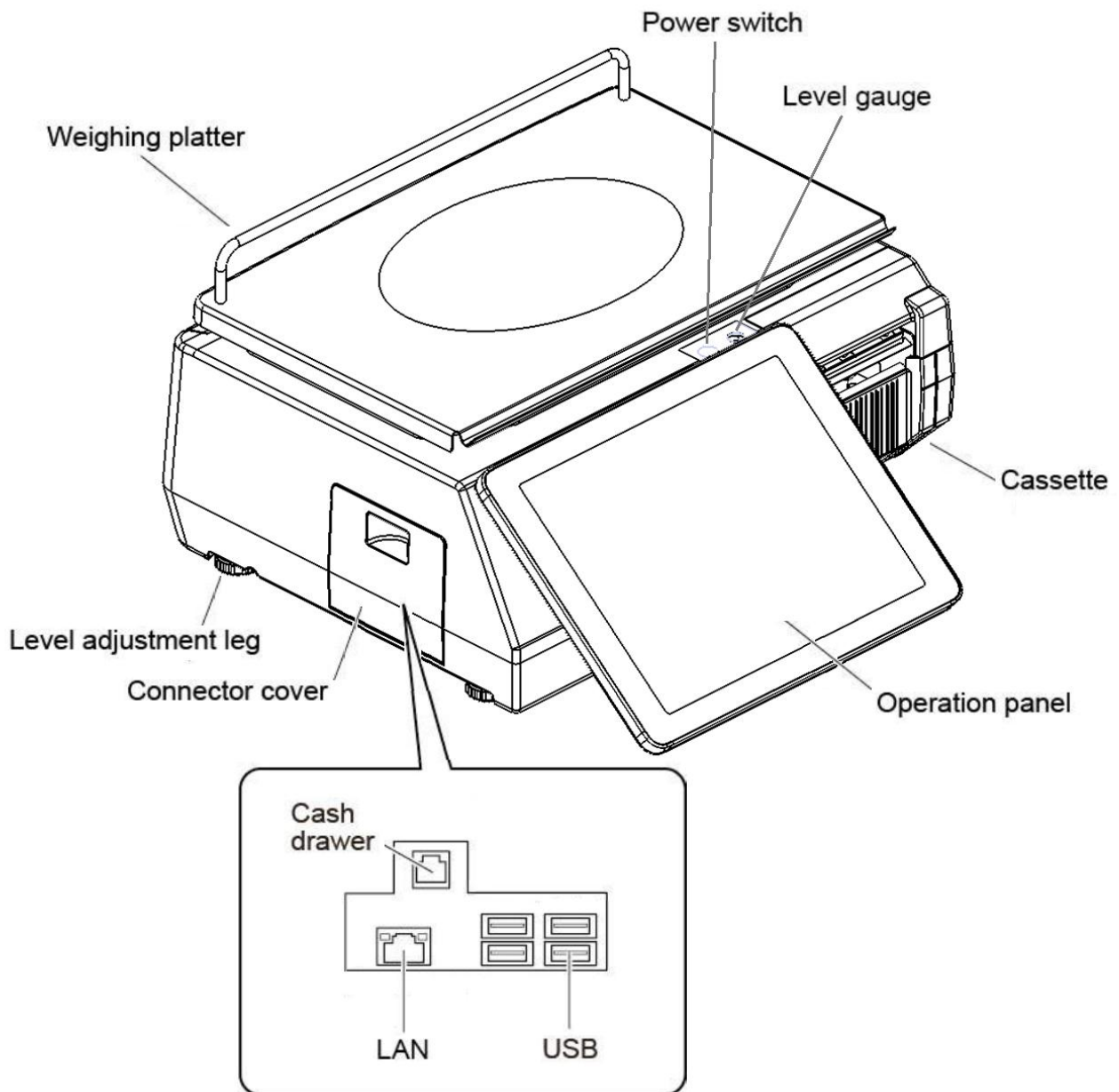

1.3 LEVEL ADJUSTMENT

CAUTION Install the machine horizontally to use.

Be sure to turn off the power switch before placing the machine on a stable platform, and adjust the machine inclination by turning the four level adjustment legs so that the bubble is located at the center of the level gauge. Accurate measurements cannot be performed if it is not installed horizontally.

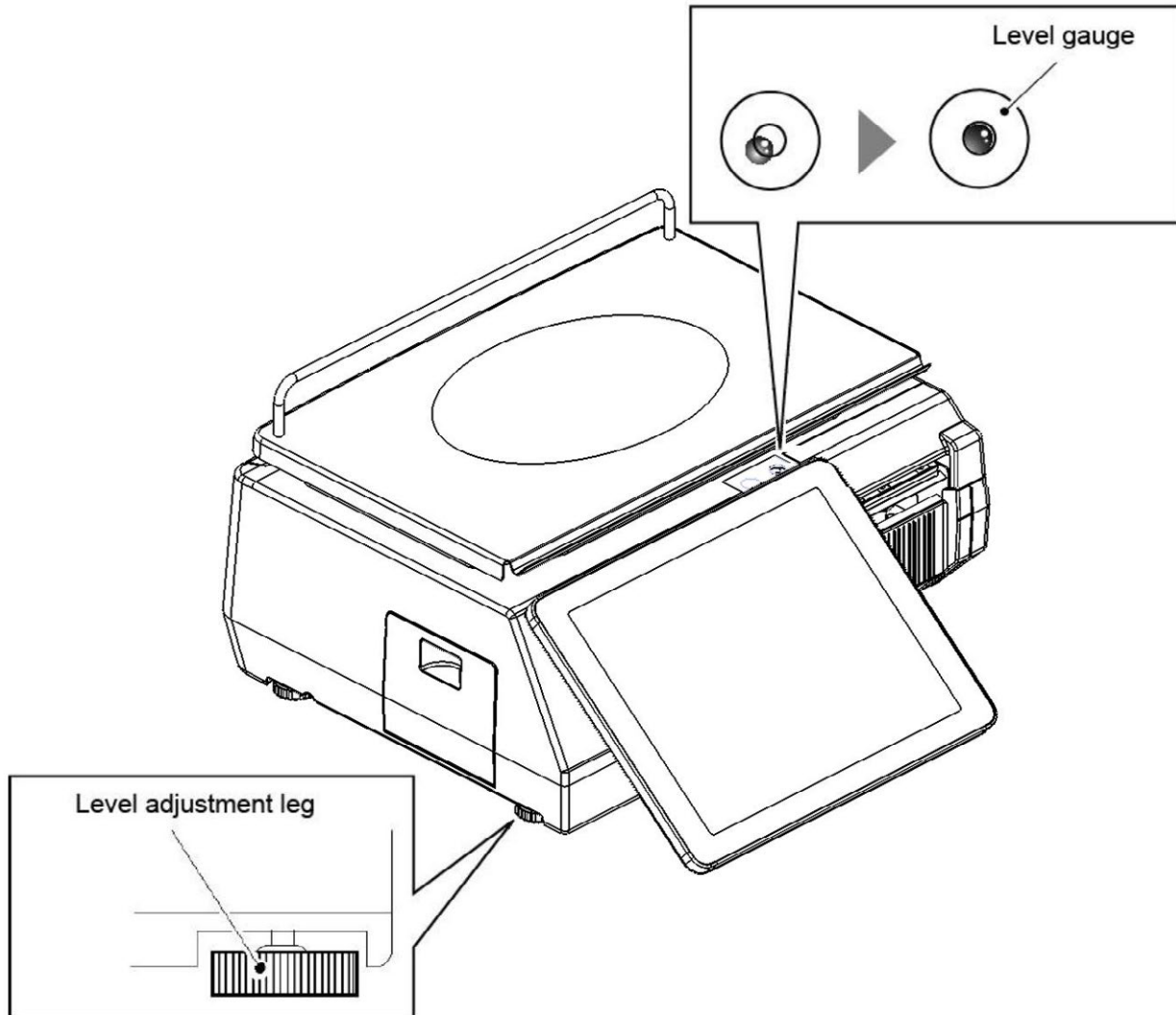

1.4 LABEL / RECEIPT ROLL LOADING

1. Raise the Thermal Head Cover, and pull the Cassette to draw out of the main body.

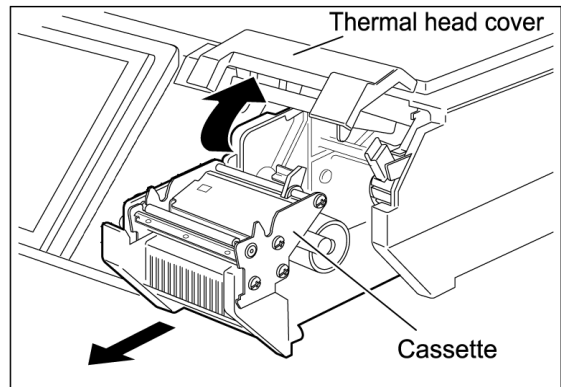

2. Load a new label roll around the Roll Holder and raise the Roll Stopper to fix the roll position.

⚠ WARNING

Confirm that the label roll can turn gently with the space from 0.5 to 2mm between the roll and the Roll Stopper.

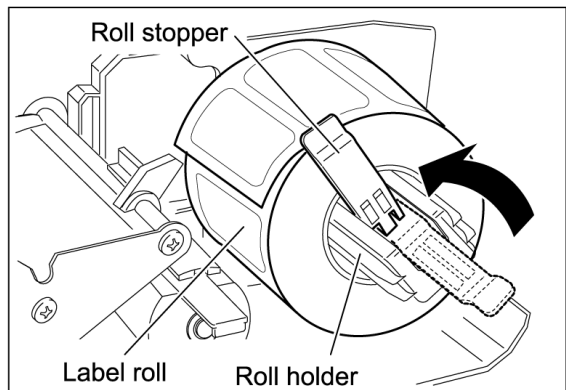

3. Thread the paper as shown in the figures below.

Label Threading

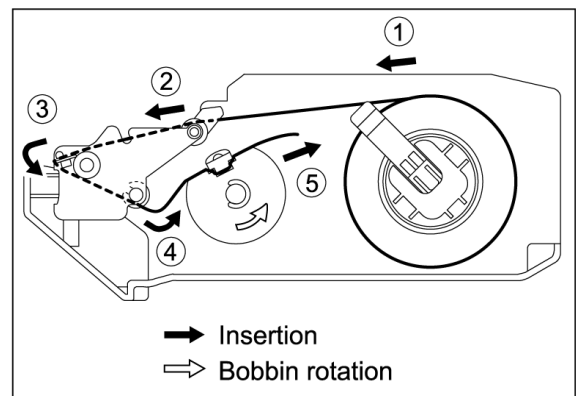

Receipt Threading

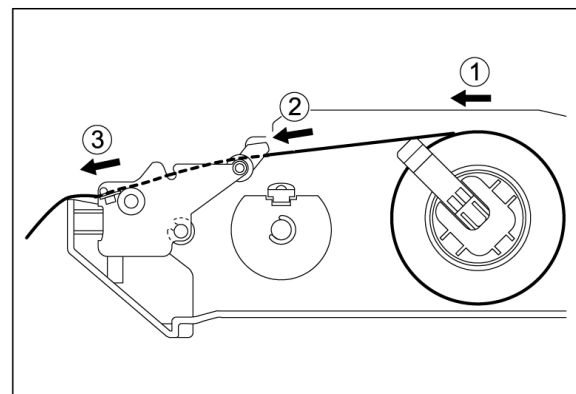

4. Fix the paper end with the backing paper stopper, and gently turn the Winding Bobbin counterclockwise until the label becomes tight.

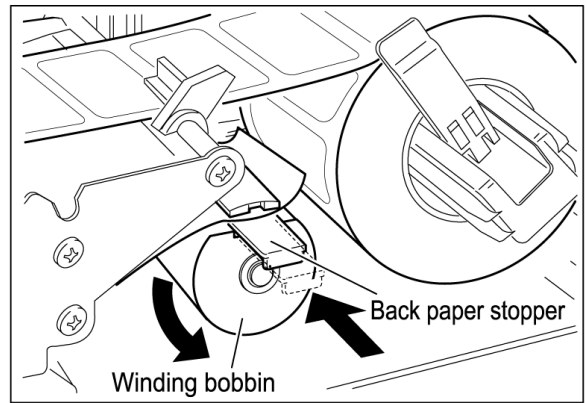

5. Slide the label/receipt guide to help smooth paper feeding according to the paper width.

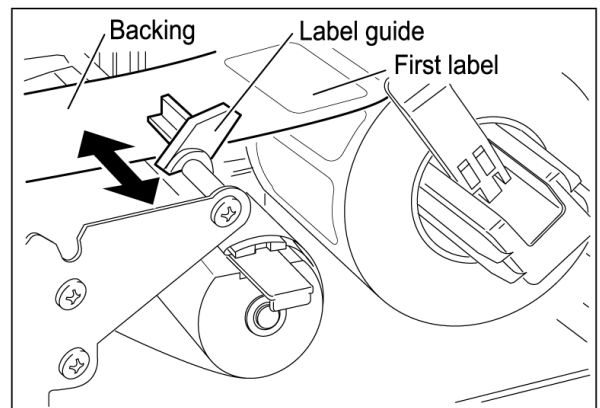

6. Push the Cassette straight into the main body to return to its original position, and lower the Thermal Head Cover.

CAUTION

Push the cassette slowly so as not to get your fingers caught between the Cassette and the main body.

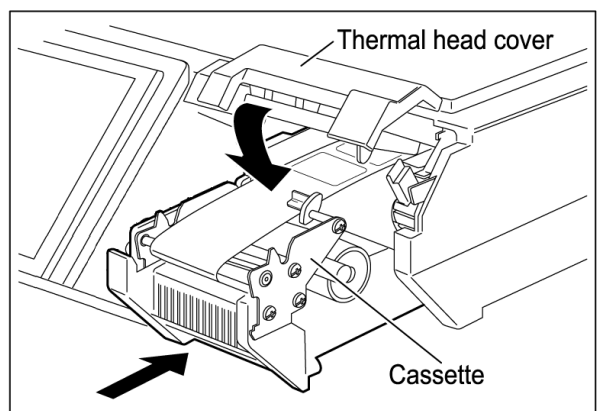

7. Press the [FEED] key to issue a label. At this time, confirm that the label is completely peeled off.

CAUTION

Confirm that the backing paper is wound up smoothly. If the backing paper is wound up diagonally, reconfirm on the label passing, label stop position with the Backing Paper Stopper, and the Label Guide width.

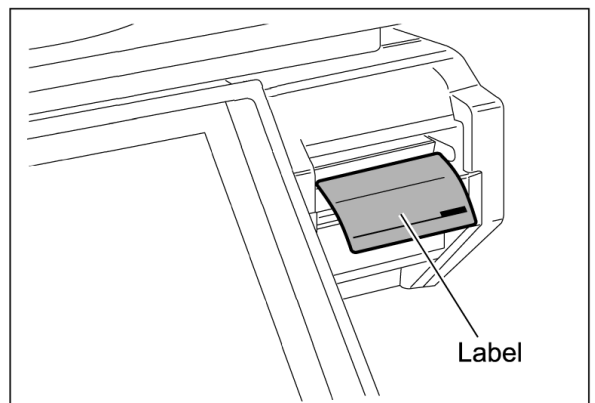

1.5 LABEL / RECEIPT ROLL LOADING

1.5.1 REMOVING THE WEIGHING PLATTER

When removing the weighing platter from the main body, lift the front side to pull out the two pins from the two rubber platter holders and remove the platter by pulling it to disengage the two hooks at the rear side of the platter.

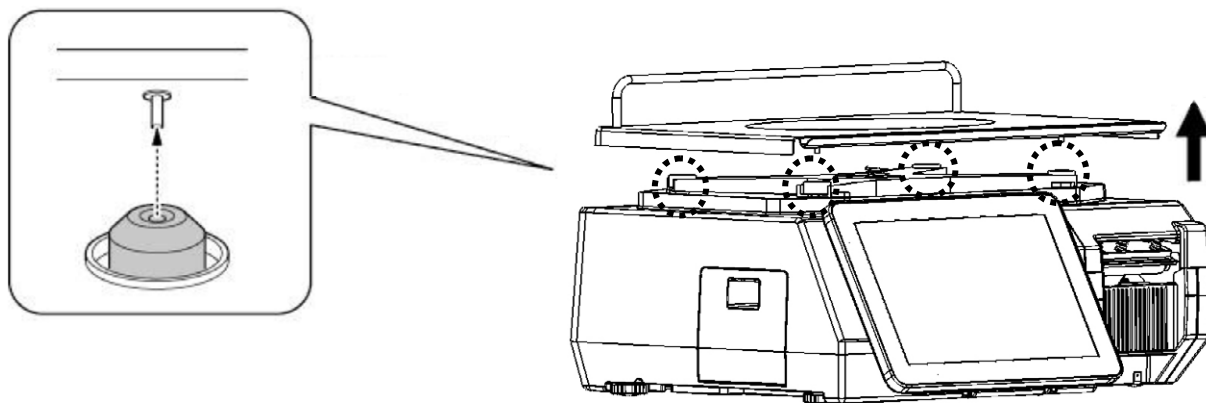

1.5.2 REPLACING THE WEIGHING PLATTER

When replacing the weighing platter onto the main body, engage the two hooks at the rear side of the platter and lower the platter so that the two pins on the bottom of the platter are inserted into holes of the rubber platter holders.

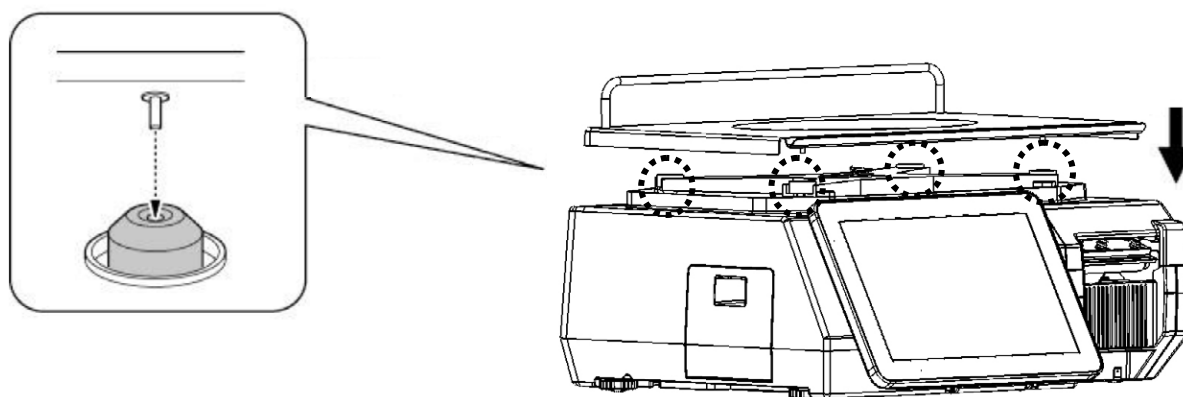

1.6 CLEANING OF THE MACHINE

1.6.1 CLEANING OF THE THERMAL HEAD

1. Pull out the cassette from the main body.

CAUTION

Before pulling out the cassette unit, ensure that nothing is placed on the weighing platter.

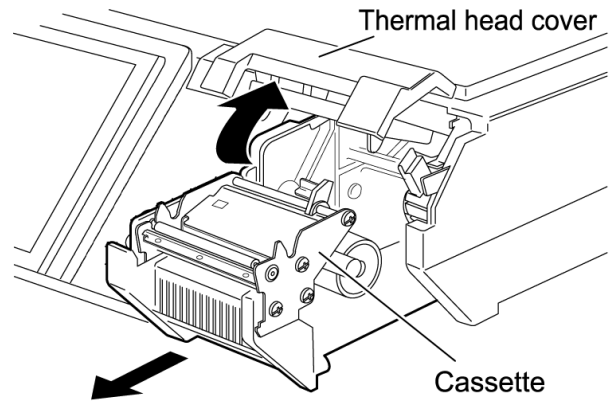

2. Use a cotton-tipped swab to clean off the thermal head.

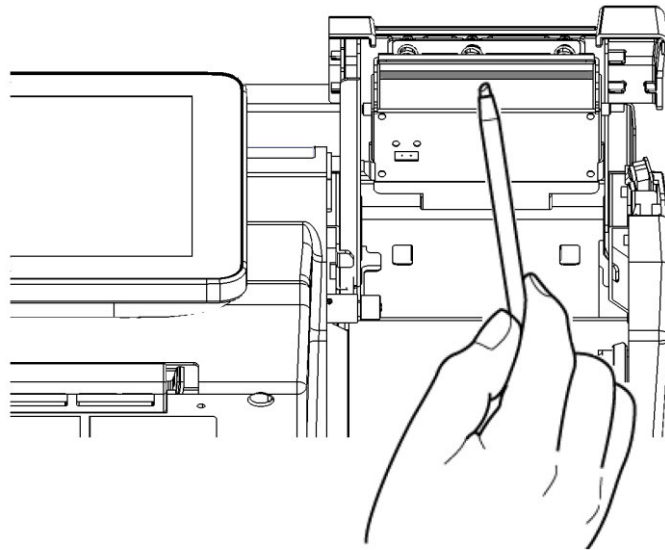

1.6.2 CLEANING OF THE LABEL SENSOR

1. Pull out the cassette from the main body.

CAUTION

Before pulling out the cassette unit, ensure that nothing is placed on the weighing platter.

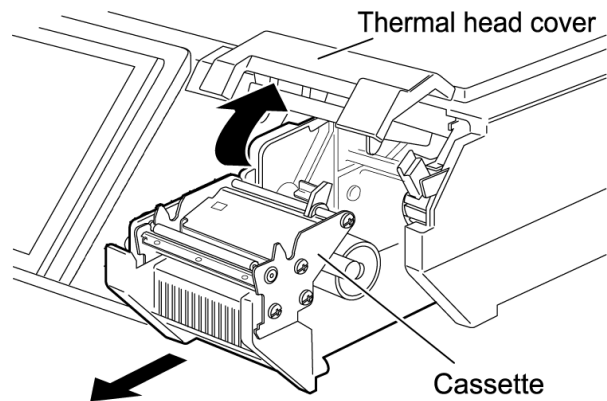

2. Use a dry cloth to clean off the emitter and receiver of the label sensor.

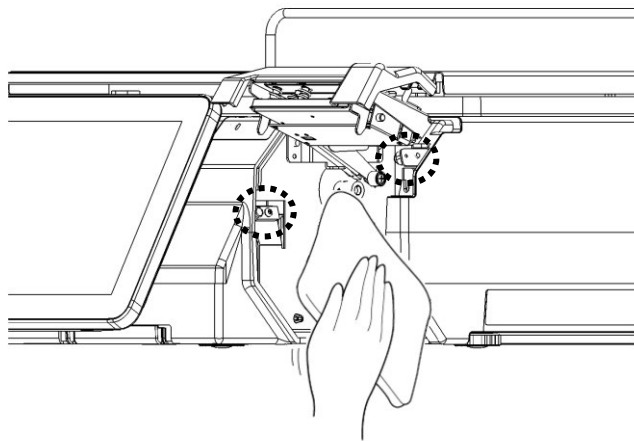

1.6.3 CLEANING OF THE PRINT ROLLER AND PRISM

1. Pull out the cassette from the main body.

CAUTION

Before pulling out the cassette unit, ensure that nothing is placed on the weighing platter.

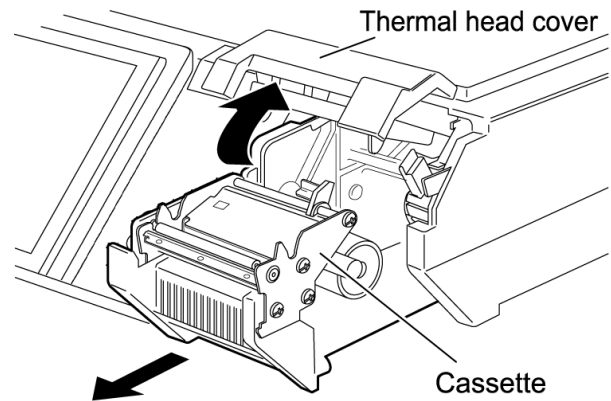

2. Use a dry cloth to clean off the print roller and prism.

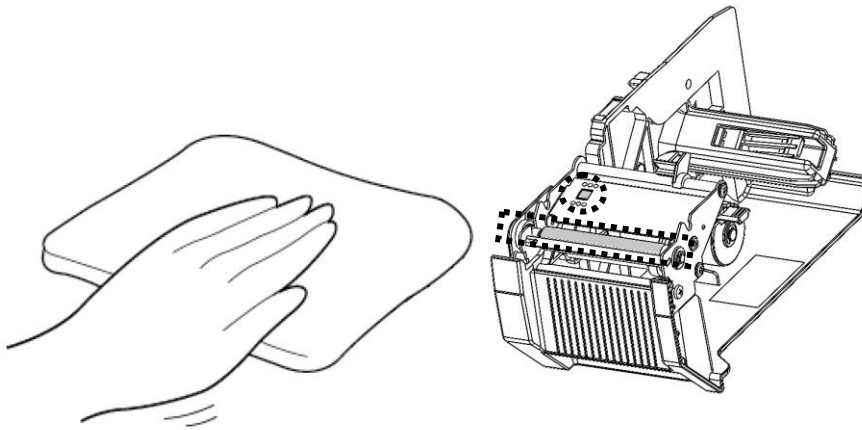

1.6.4 PRECAUTIONS WHEN USING CLEANING FLUIDS

CAUTION

Use a soft cloth and a neutral detergent to clean the machine.
Do not use thinner, benzene, etc. Doing so may damage the original safety functions.
For some parts, use cleaning fluid (isopropyl alcohol).

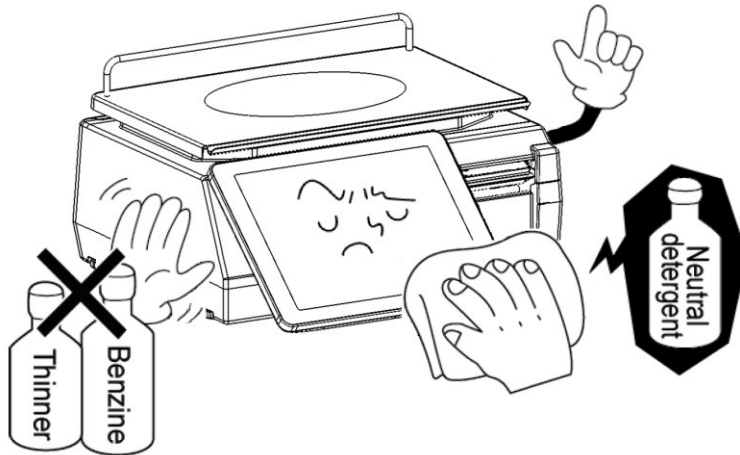

CAUTION

- † Do not use cleaning fluid near fire as the fluid is flammable.
- † Do not use cleaning fluid in a poorly ventilated area. Always provide adequate ventilation when cleaning.

Take the following actions in the event of an accident:

If the fluid gets in your eye

- † Immediately wash your eye(s) with water for at least 15 minutes, and consult your doctor.
- † If you wear contact lenses, remove and wash them.

If the fluid comes into contact with your skin

- † Immediately rinse the area of contact with water, and then wash with soap.
- † If you notice any skin abnormalities at the area of contact, or if any pain persists, consult your doctor.

If the fumes of the fluid are inhaled

- † Immediately move the victim to an area where fresh air is available, and have the victim lie down and keep warm.
- † If breathing becomes difficult or stops, provide artificial respiration and seek medical attention immediately.

If the fluid is swallowed

- † Do not try to induce vomiting.
- † Do not give the victim anything to drink, and do not rinse the mouth.
- † If vomiting occurs naturally, have the victim lean forward to reduce risk of aspiration.
- † Keep the victim warm and seek medical attention.

1.7 STARTING PROCEDURES

1.7.1 TURNING ON THE POWER

1. Push down the Power Switch to turn on the power.

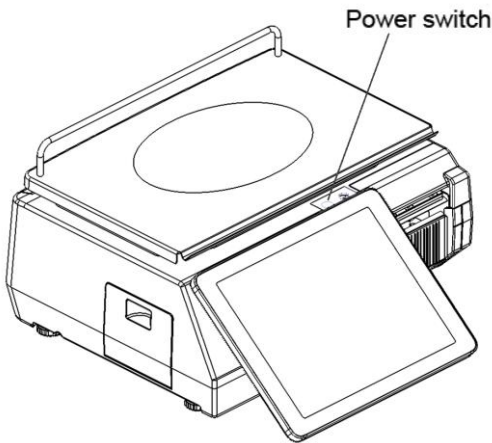

2. The “Clock Check” screen is displayed. Check that displayed date and time agree with the current date and time, and press the [ENTER] button on the screen to proceed to the next step.

Note: Refer to the “Date/Time” menu in Adjustment Mode when changing date or time.

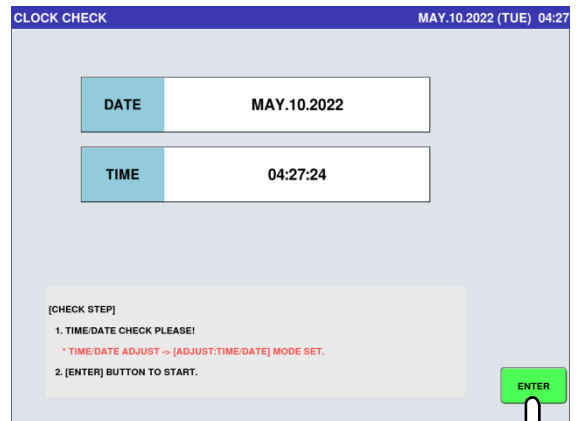

3. The initial screen is displayed. **Note:** The contents of the initial screen may differ depending on the settings on your machine.

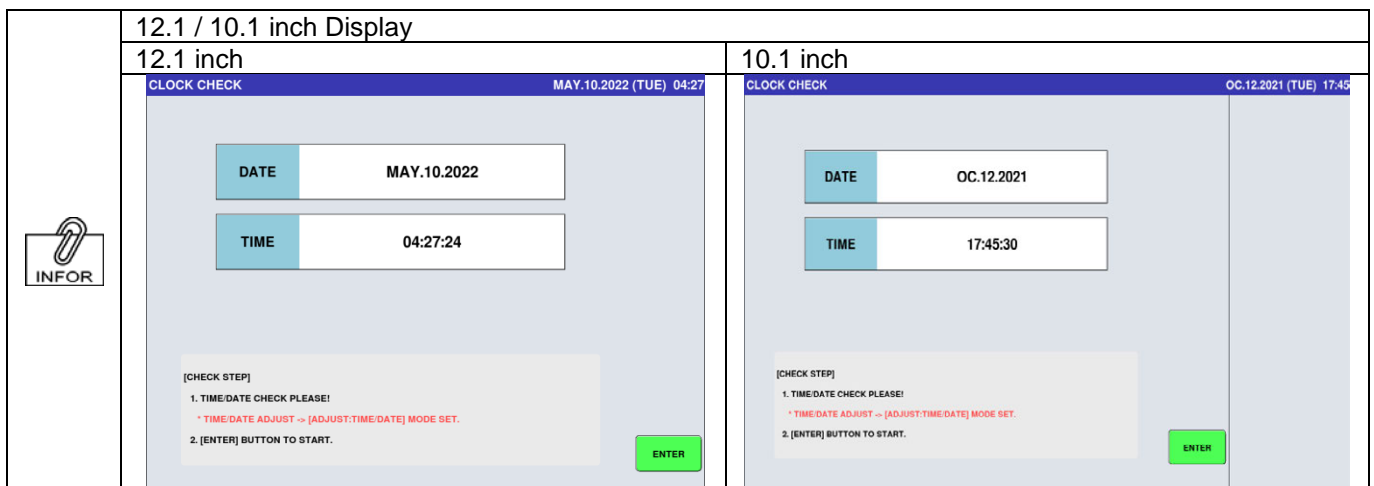
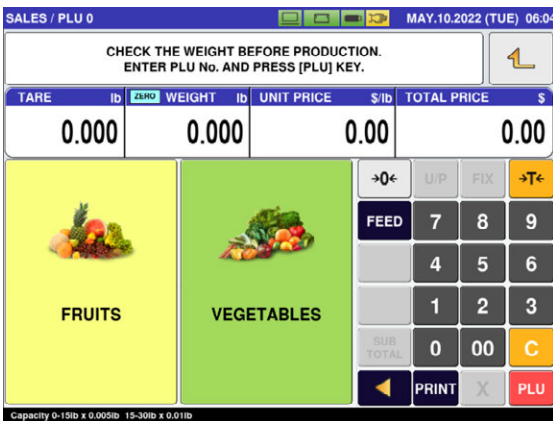

1.7.2 ZERO ADJUSTMENT

1. If the “ZERO” indicator does not appear in the “WEIGHT” field on the initial screen, press the [ZERO] key.
2. The “ZERO” indicator lights up and the weight value becomes zero.

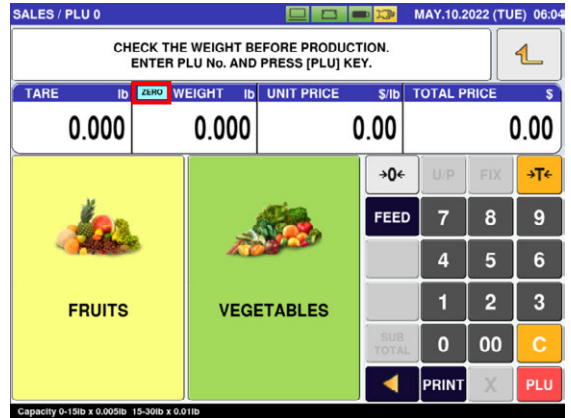

1.7.3 GETTING BACK TO THE INITIAL SCREEN

1. To get back to the initial screen from a Menu selection screen, press the [SALES] button” at the bottom right on the screen.
2. The initial screen is displayed. **Note:** The contents of the initial screen may differ depending on the settings on your machine.

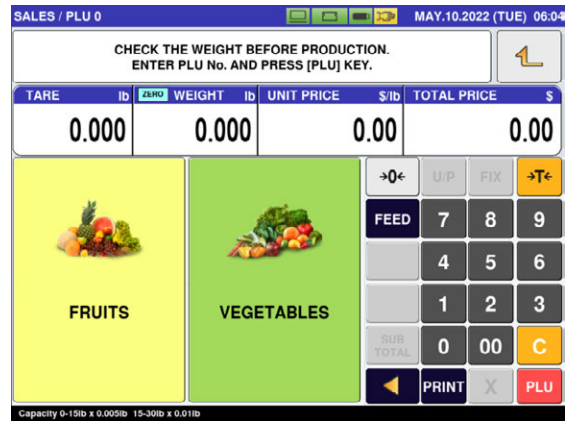
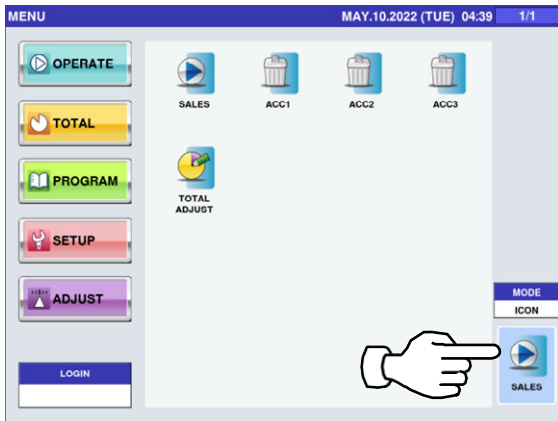

	12.1 / 10.1 inch Display	10.1 inch
	<p>12.1 inch</p>	<p>10.1 inch</p>
	<p>Capacity 0-15lb x 0.005lb 15-30lb x 0.01lb</p>	<p>Capacity 0-15lb x 0.005lb 15-30lb x 0.01lb</p>

OPERATION MODE

2.1 OPERATION MODE ENTRY / EXIT

Ensure that the initial screen is displayed. Then, press the Return button to display the "Menu" screen.

Note: The contents of the initial screen may differ depending on the settings on your machine.

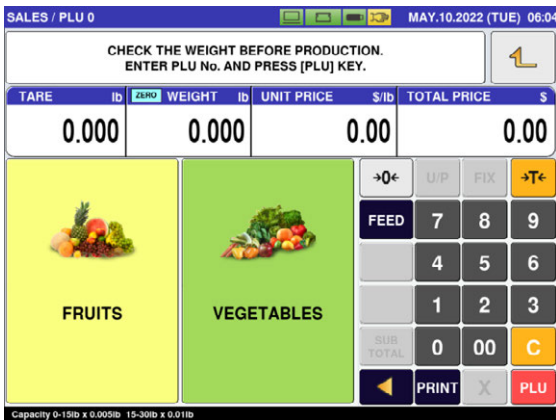

The "Menu" screen is displayed.

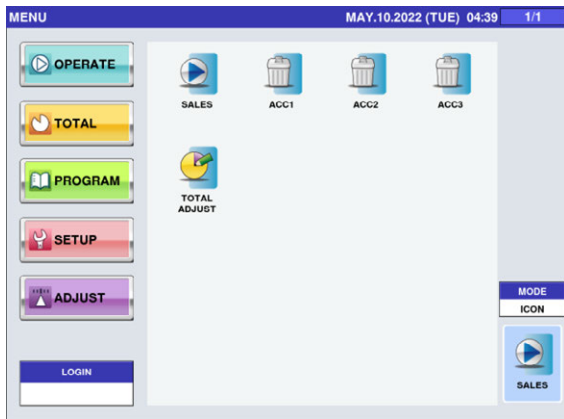

Note: To exit the Operation Mode, press the [SALES] button.

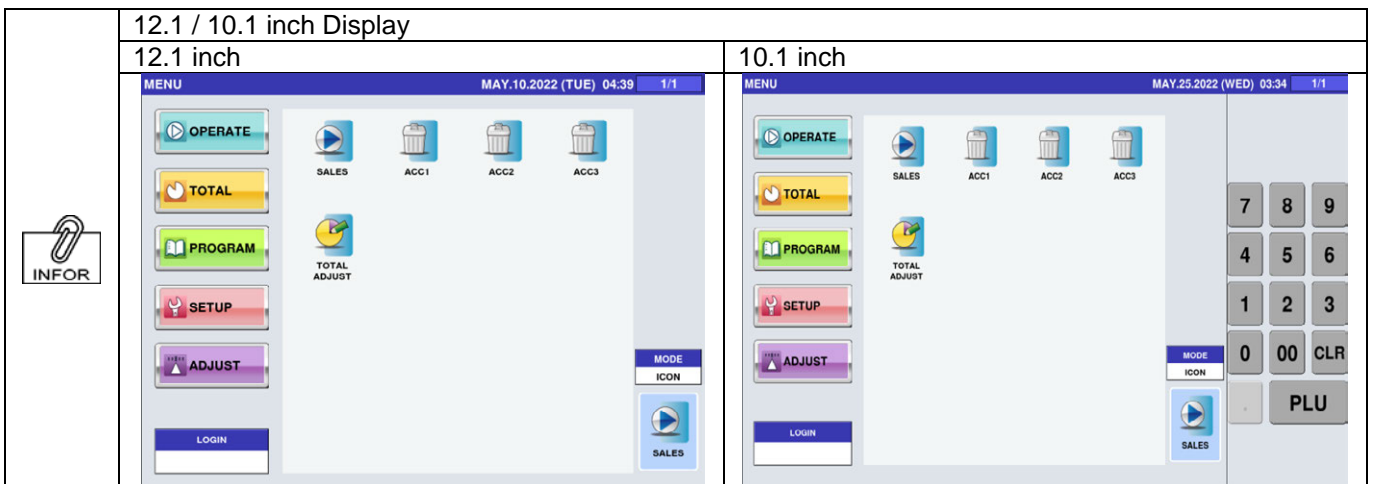

2.2 SCREEN EXAMPLES FOR PRODUCT CATEGORIES

Weighing Products

SALES / PLU 1 MAY.10.2022 (TUE) 06:43

BANANE BANANA

TARE	lb	ZERO	WEIGHT	lb	UNIT PRICE	\$/lb	TOTAL PRICE	\$
0.000			0.000		1.23		0.00	

PACK DATE
MAY.10.2022

SELL BY DATE
MAY.11.2022

OPE 1 OPE 2 OPE 3

OPE 4 OPE 5 OPE 6

OPE 7 OPE 8 OPE 9

OPE 10 →0← DISP IMG LD.

CSIS

PRN MD.
MANUAL

PEEL MD.
PEEL

- %
0.0

SPECIAL
0.00

-(U/P)
0.0

→T←

→0←

TARE 0.012kg

TARE 0.018kg

- \$
0.00

SP.(U/P)
0.00

-(U/P)
0.0

U/P

FIX

FEED

7 8 9

4 5 6

1 2 3

SUB TOTAL 0 00

PRINT X

Capacity 0-15lb x 0.005lb 15-30lb x 0.01lb

Weighing Fixed Price Products

SALES / PLU 1 MAY.10.2022 (TUE) 06:44

BANANE BANANA

TARE	lb	ZERO	WEIGHT	lb	FIXED PRICE	\$
0.000			0.000		1.23	

PACK DATE
MAY.10.2022

SELL BY DATE
MAY.11.2022

OPE 1 OPE 2 OPE 3

OPE 4 OPE 5 OPE 6

OPE 7 OPE 8 OPE 9

OPE 10 →0← DISP IMG LD.

CSIS

PRN MD.
MANUAL

PEEL MD.
PEEL

- %
0.0

SPECIAL
0.00

-(U/P)

→T←

→0←

TARE 0.012kg

TARE 0.018kg

- \$
0.00

SP.(U/P)

-(U/P)

U/P

FIX

FEED

7 8 9

4 5 6

1 2 3

SUB TOTAL 0 00

PRINT X

Capacity 0-15lb x 0.005lb 15-30lb x 0.01lb

Non-weighing Fixed Price Products

SALES / PLU 1 MAY.10.2022 (TUE) 06:46

**BANANE
BANANA**

PCS	@/	UNIT PRICE	\$	TOTAL PRICE	\$
1		1	1.23		1.23

PACK DATE MAY.10.2022		CSIS		→0←	U/P	FIX	
SELL BY DATE MAY.11.2022		PRN MD. MANUAL	TARE 0.012kg	FEED	7	8	9
OPE 1	OPE 2	OPE 3	PEEL MD. PEEL	TARE 0.018kg		4	5
OPE 4	OPE 5	OPE 6	- % 0.0	- \$ 0.00		1	2
OPE 7	OPE 8	OPE 9	SPECIAL 0.00	SP.(U/P) 0.00	SUB TOTAL	0	00
OPE 10	→0←	DISP IMG LD.	-(U/P) 0.0	-(U/P) 0.00	PRINT	X	PLU

Capacity 0-15lb x 0.005lb 15-30lb x 0.01lb

Non-weighing Fixed Weight/Unit Price Products

SALES / PLU 1 MAY.10.2022 (TUE) 06:47

**BANANE
BANANA**

MANUAL WT	lb	FIXED U.PRI	\$/lb	TOTAL PRICE	\$
		1.23		0.00	

PACK DATE MAY.10.2022		CSIS		→0←	U/P	FIX	
SELL BY DATE MAY.11.2022		PRN MD. MANUAL	TARE 0.012kg	FEED	7	8	9
OPE 1	OPE 2	OPE 3	PEEL MD. PEEL	TARE 0.018kg		4	5
OPE 4	OPE 5	OPE 6	- % 0.0	- \$ 0.00		1	2
OPE 7	OPE 8	OPE 9	SPECIAL 0.00	SP.(U/P) 0.00	SUB TOTAL	0	00
OPE 10	→0←	DISP IMG LD.	-(U/P) 0.0	-(U/P) 0.00	PRINT	X	PLU

Capacity 0-15lb x 0.005lb 15-30lb x 0.01lb

2.3 SALES OPERATIONS

2.3.1 ISSUING LABELS FOR WEIGHING PRODUCTS

1. Press the "SALES" icon on the operation menu selection screen.

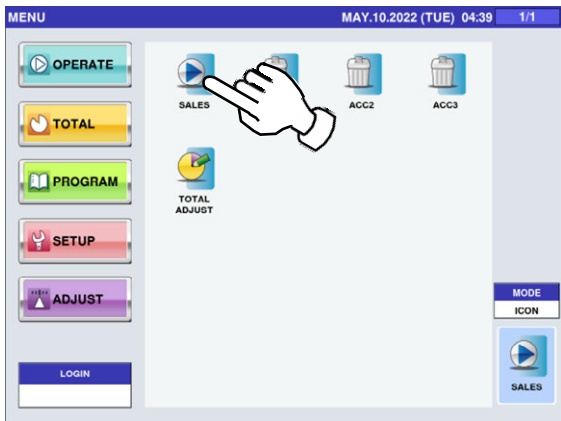

The initial screen is displayed. *Note: The contents of the initial screen may differ depending on the settings on your machine.*

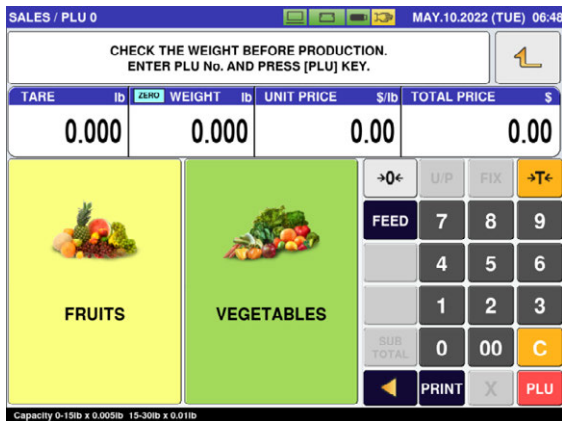

2. Enter a PLU number and press the [PLU] key on the keypad. *Note: If "ZERO" is not indicated on the screen, press [→0←] on the keypad.*

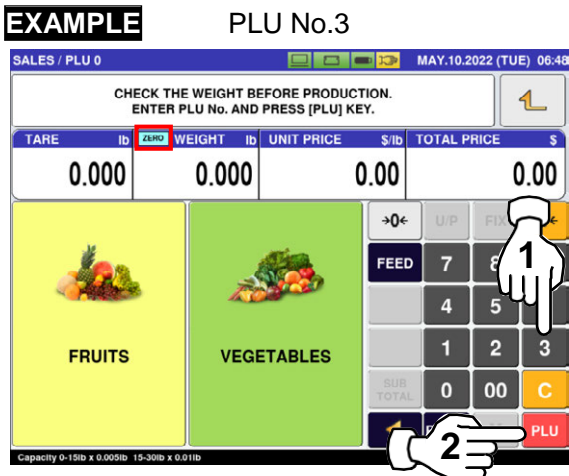

OR Press a preset product department key to display the associated screen.

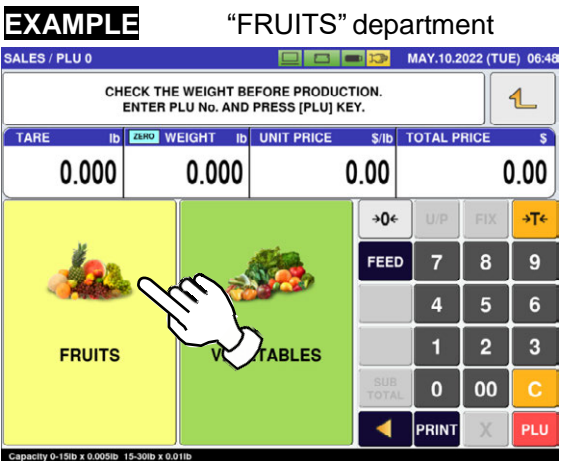

Then, press the preset PLU key where the product is assigned.

EXAMPLE "Red Grape" (weighing product)

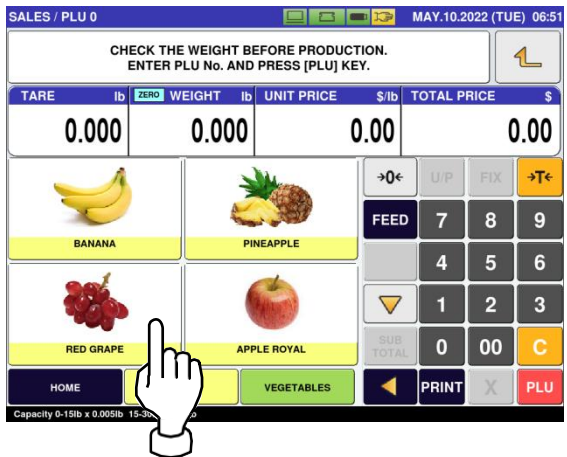

3. The designated weighing PLU screen is displayed.

EXAMPLE

A product to which its unit price and tare weight were set beforehand.

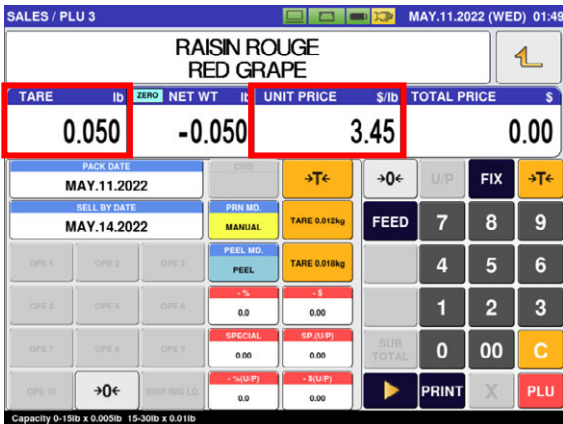

4. Put the product on the weighing platter.



The product is weighed and its total price is calculated.

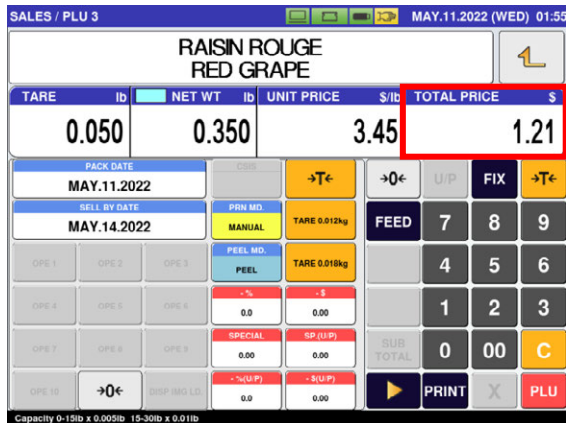

5. Press the [PRINT] key to issue a label when "MANUAL" is set in the "Print Mode" field.
Note: A label is automatically issued when "AUTO" is set in the "Print Mode" field.

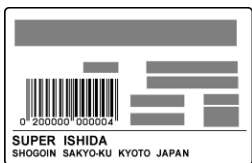
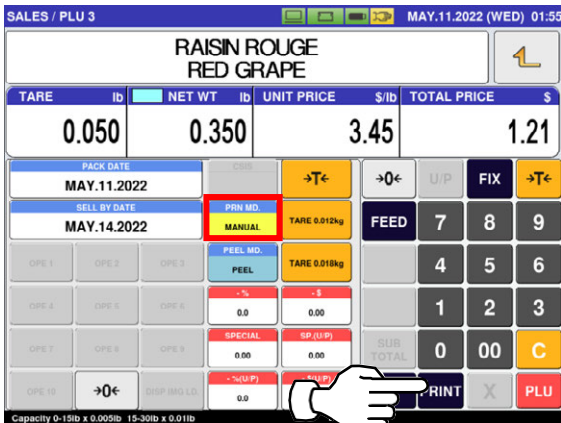

Non-traceable products



Traceable products

2.3.2 ISSUING LABELS FOR WEIGHING FIXED PRICE PRODUCTS

1. Press the "SALES" icon on the operation menu selection screen.

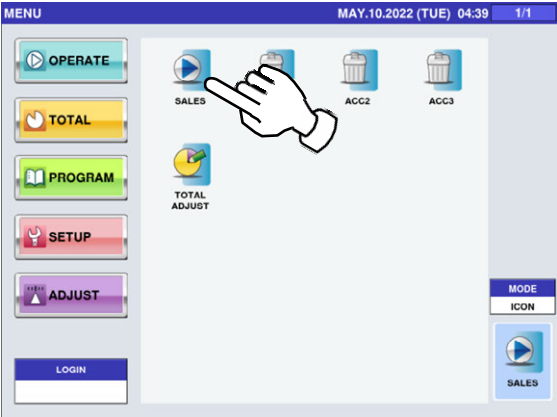

➔ The initial screen is displayed.
Note: The contents of the initial screen may differ depending on the settings on your machine.

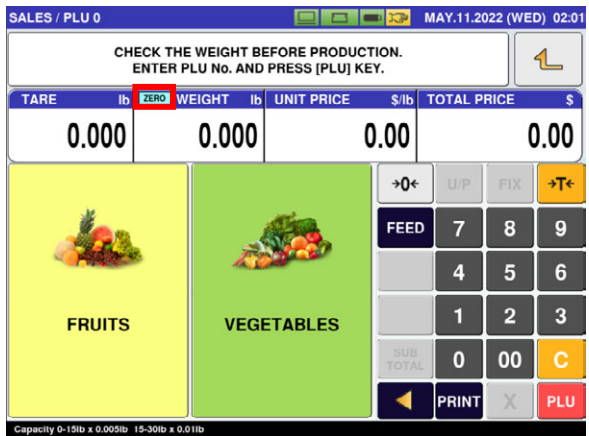

2. Enter a PLU number and press the [PLU] key on the keypad.
Note: If "ZERO" is not indicated on the screen, press [→0←] on the keypad.

EXAMPLE PLU No.29

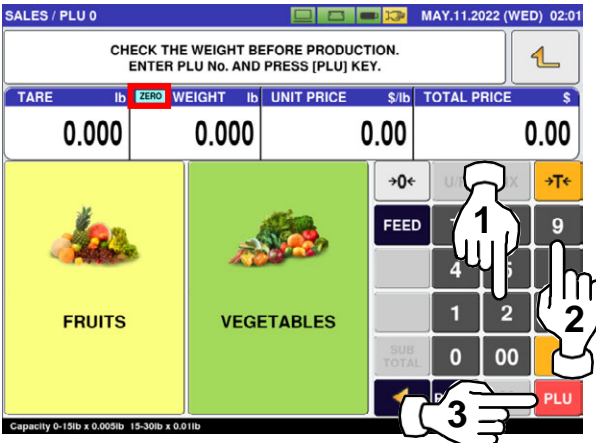

OR Press a preset product department key to display the associated screen.

EXAMPLE "VEGETABLES" department

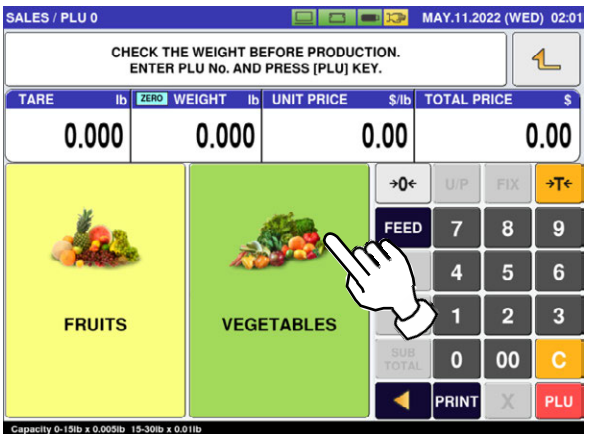

Then, press the preset PLU key where the product is assigned.

EXAMPLE "ANISE" (weighing product)

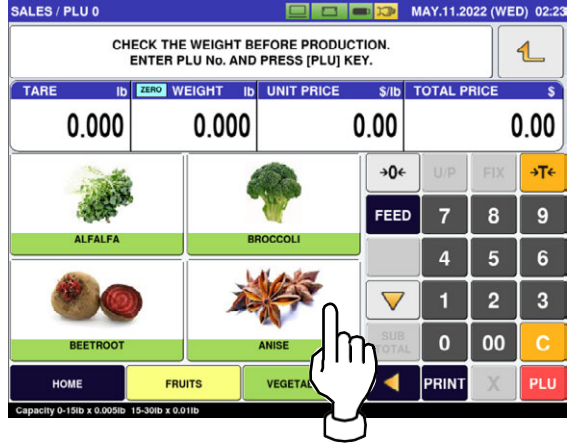

3. The designated weighing PLU screen is displayed.
EXAMPLE
 A product to which its tare weight and price were set beforehand.

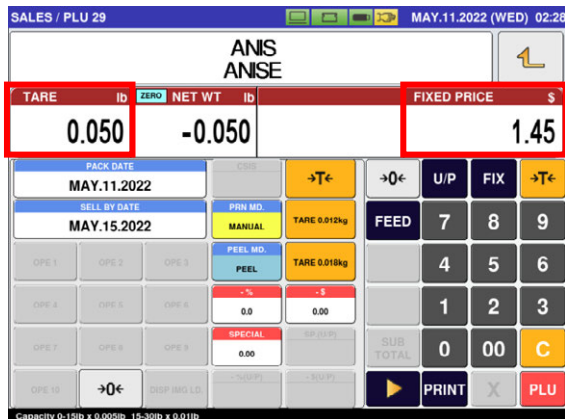

4. Put the product on the weighing platter.

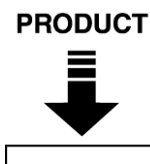

The product is weighed, but its price stays the same.



5. Press the [PRINT] key to issue a label when "MANUAL" is set in the "Print Mode" field.
Note: A label is automatically issued when "AUTO" is set in the "Print Mode" field.

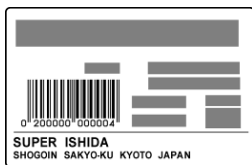
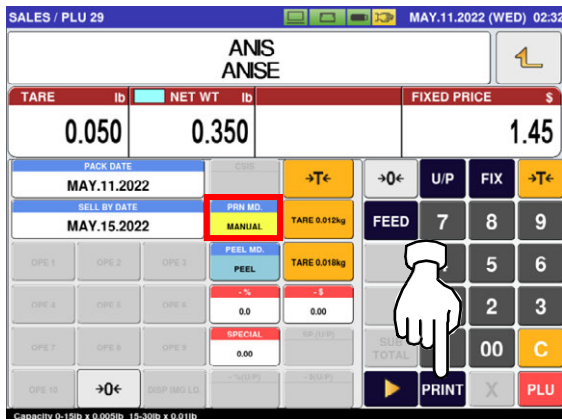

Non-traceable products



Traceable products

2.3.3 ISSUING LABELS FOR FIXED PRICE PRODUCTS

1. Press the "SALES" icon on the operation menu selection screen.

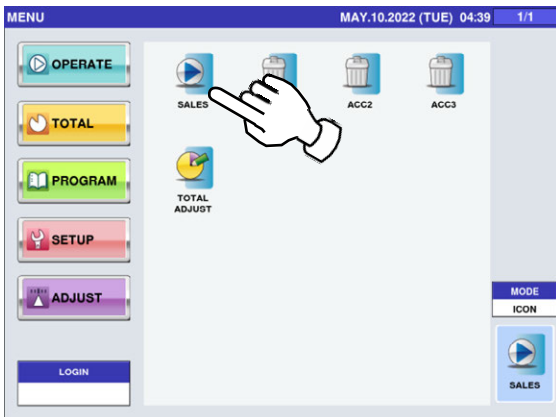

➔ The initial screen is displayed.
Note: The contents of the initial screen may differ depending on the settings on your machine.

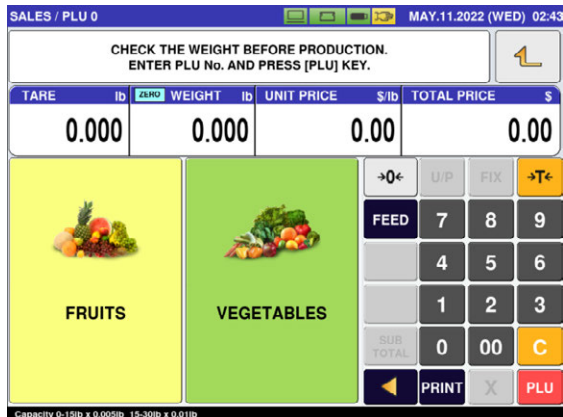

2. Enter a PLU number and press the [PLU] key on the keypad.
Note: If "ZERO" is not indicated on the screen, press [→0←] on the keypad.

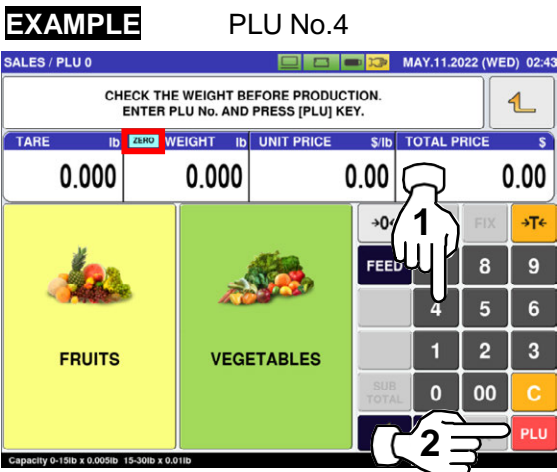

OR Press a preset product department key to display the associated screen.

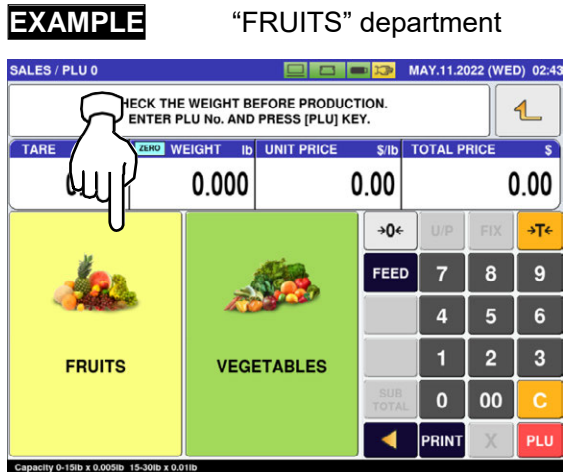

Press the preset PLU key where the product is assigned.

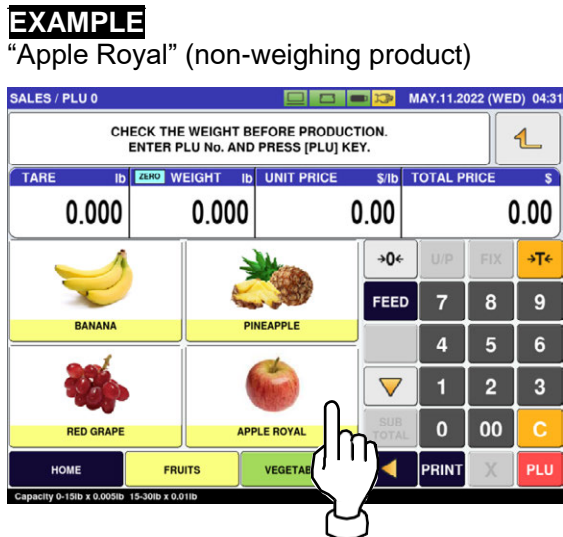

3. The designated non-weighing PLU screen is displayed.

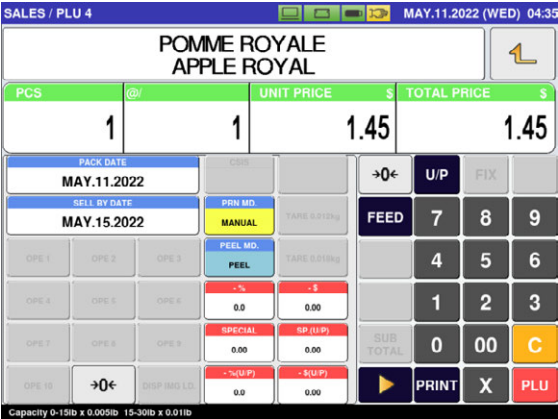

4. Press the [PRINT] key to issue labels when "MANUAL" is set in the "Print Mode" field. *Note: Labels are automatically issued when "AUTO" is set in the "Print Mode" field.*

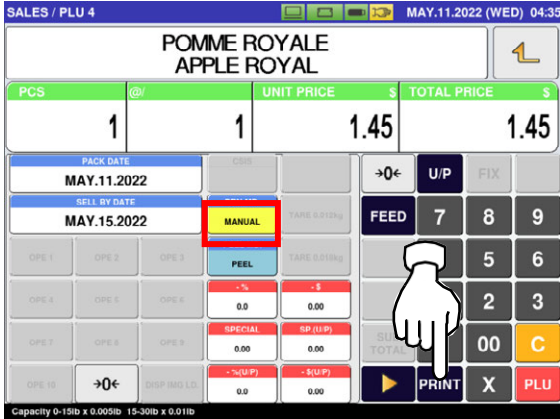

Non-traceable products

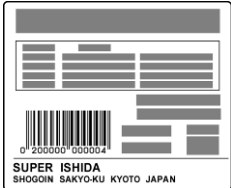

Traceable products

Note: To stop printing, press the [PRINT] key again.

2.3.4 ISSUING LABELS FOR FIXED WEIGHT/UNIT PRICE PRODUCTS

1. Press the "SALES" icon on the operation menu selection screen.

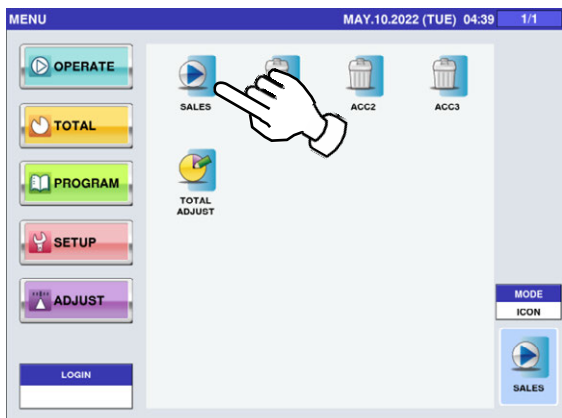

The initial screen is displayed.
Note: The contents of the initial screen may differ depending on the settings on your machine.

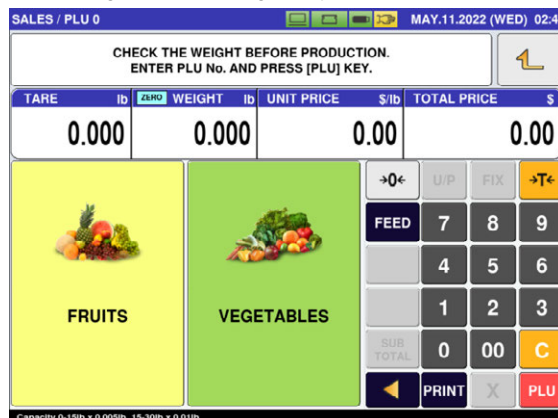

2. Enter a PLU number and press the [PLU] key on the keypad.
Note: If "ZERO" is not indicated on the screen, press [→0<] on the keypad.

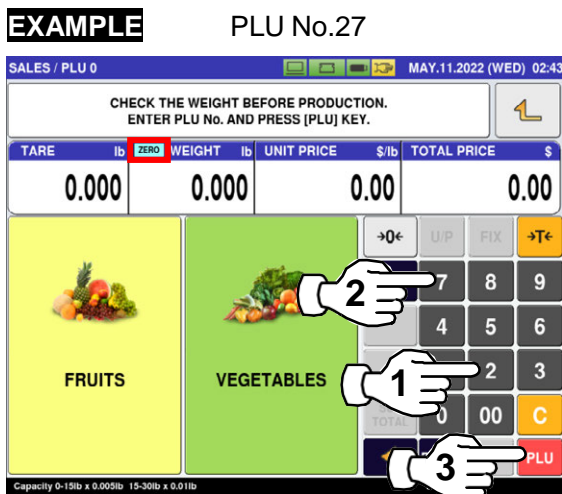

OR Press a preset product department key to display the associated screen.

EXAMPLE "VEGETABLES" department

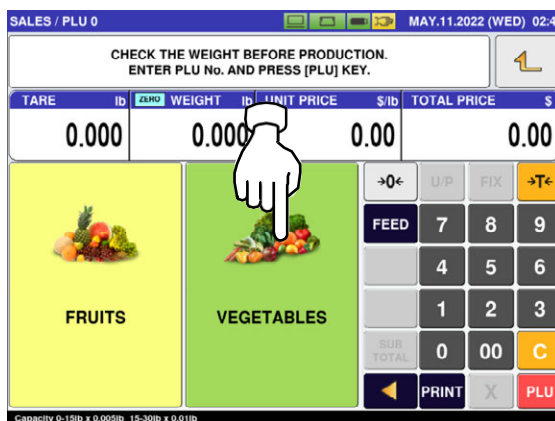

Press the preset PLU key where the product is assigned.

EXAMPLE "BROCCOLI" (non-weighing product)

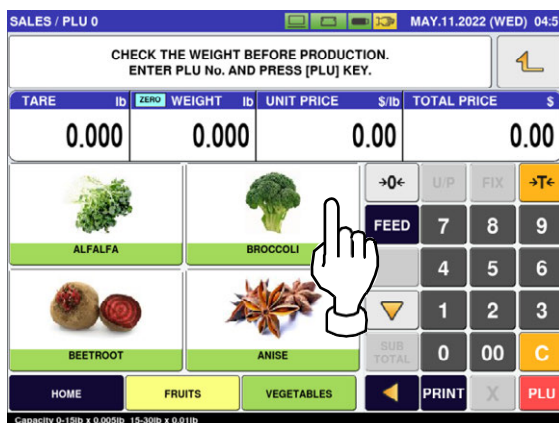

3. The designated non-weighing PLU screen is displayed.

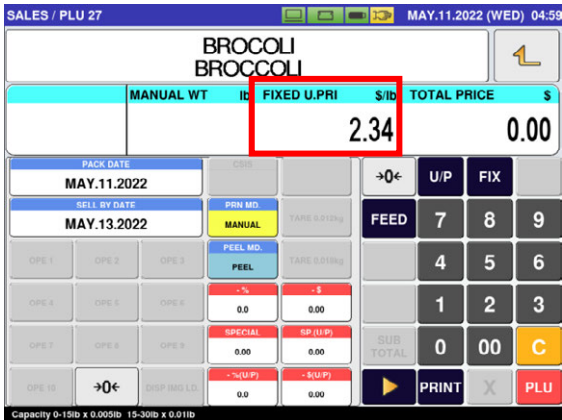

4. Enter the fixed weight and press the "FIXED WEIGHT" field.
EXAMPLE Fixed weight "159 g"

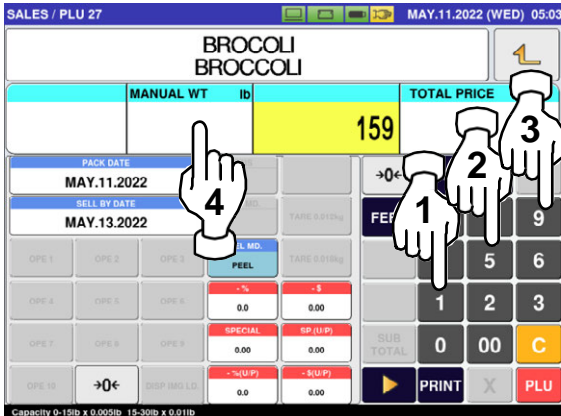

5.

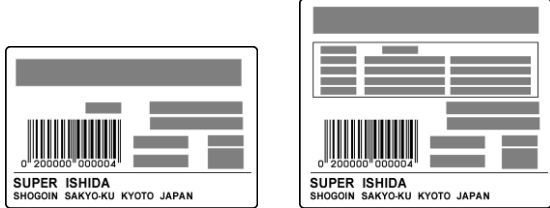
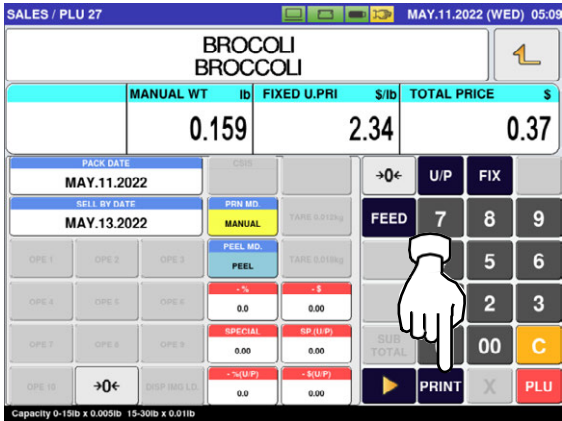

Non-traceable products

Traceable products

Note: To stop printing, press the [PRINT] key again.

2.3.5 ISSUING LABELS REQUIRING OPERATOR REGISTRATION

1. Press the "SALES" icon on the operation menu selection screen.

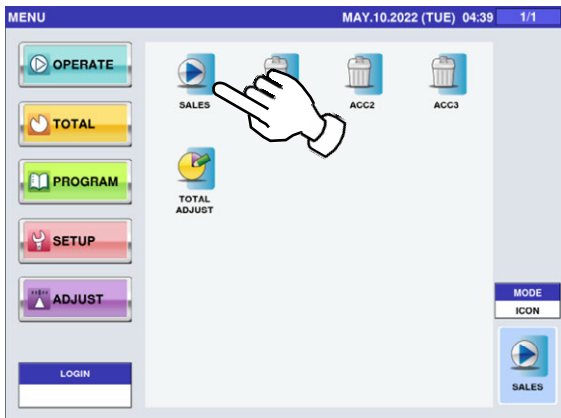

➔ The initial screen is displayed.
Note: The contents of the initial screen may differ depending on the settings on your machine.



2. Enter a PLU number and press the [PLU] key on the keypad.
Note: If "ZERO" is not indicated on the screen, press [→0←] on the keypad.

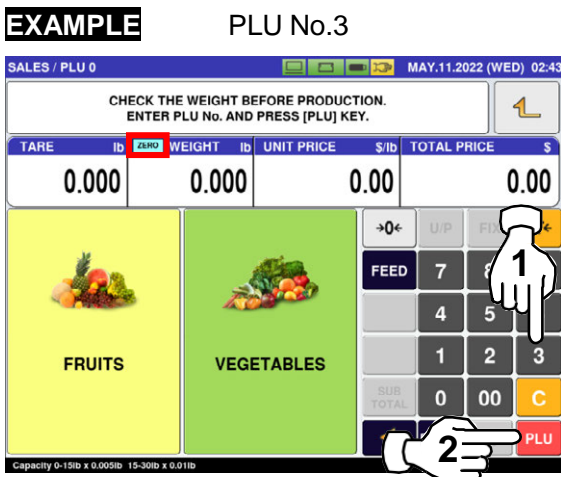

OR Press a preset product department key to display the associated screen.

EXAMPLE "FRUITS" department

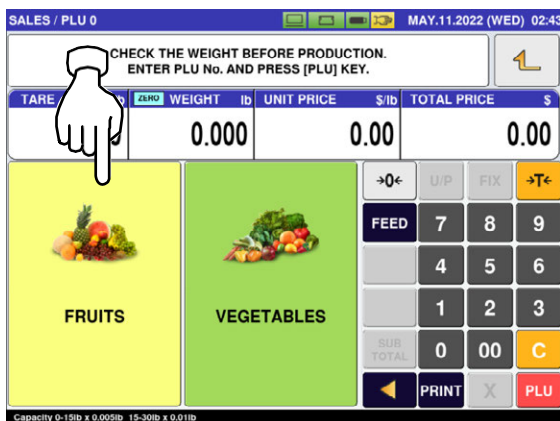

Press the preset PLU key where the product is assigned.

EXAMPLE "Red Grape" (weighing product)

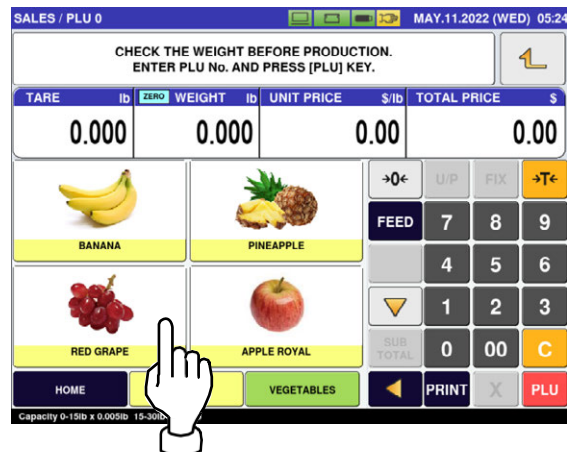

3. The designated PLU screen is displayed.
EXAMPLE
 A product to which its unit price and tare weight were set beforehand.

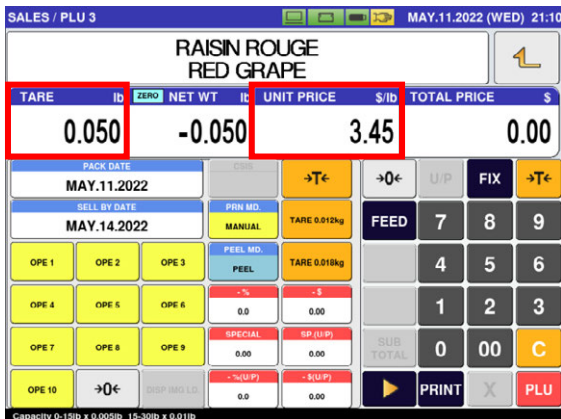

4. Put the product on the weighing platter.



The product is weighed and its total price is calculated.

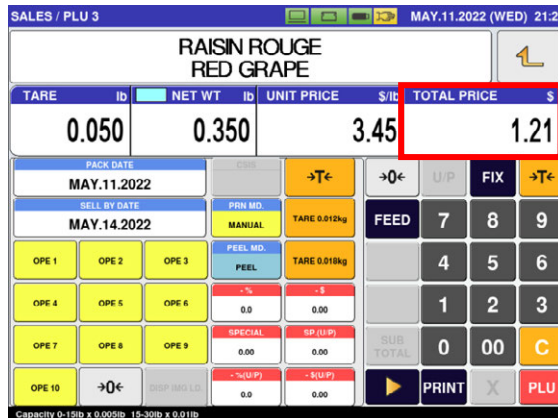

5. Press an operator button to issue a label.
EXAMPLE Operator "OPE 2"

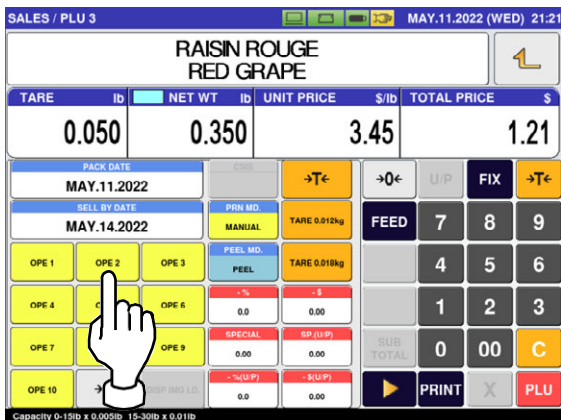

Non-traceable products



Traceable products

2.3.6 ENTERING OR OVERWRITING TARE WEIGHTS

- 1. Ensure that the designated PLU screen is displayed.

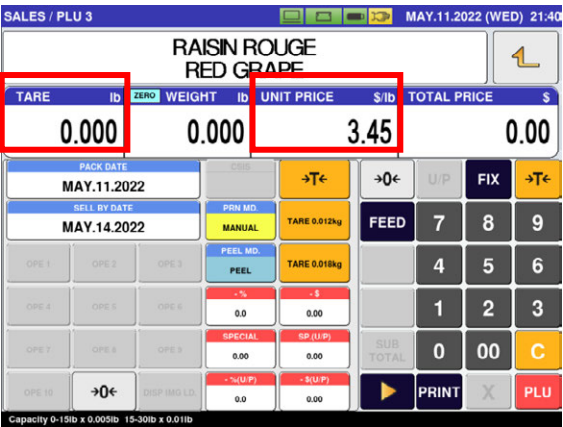

- 2. Enter a numerical value and press the [→T←] (Tare) key.

EXAMPLE Tare weight "50 g"

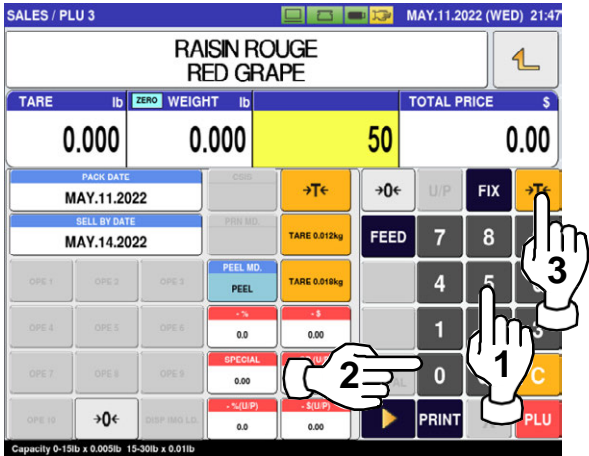

2.3.7 CHANGING UNIT PRICES

- 1. Ensure that the designated PLU screen is displayed.

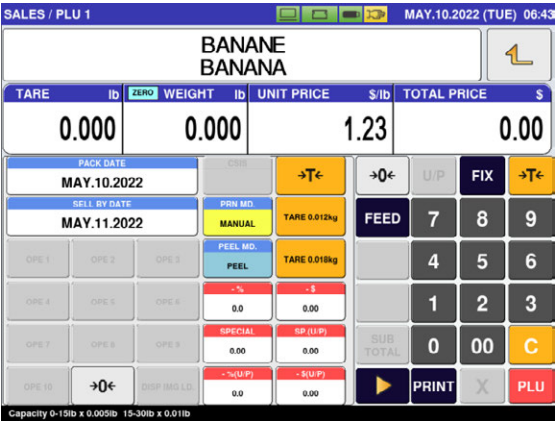

- 2. Enter the unit price and press the "UNIT PRICE" field.

EXAMPLE "\$1.56"

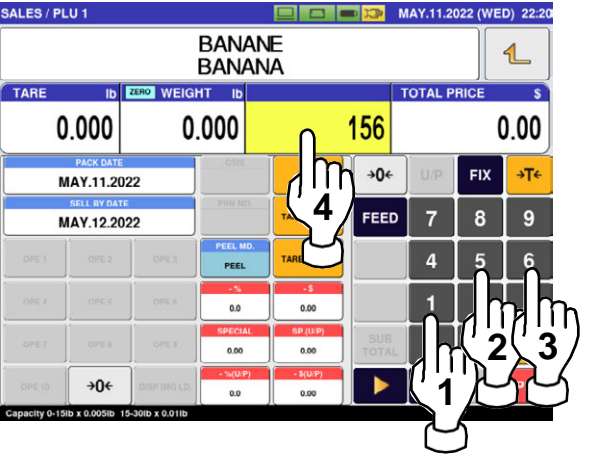

2.3.8 CHANGING FIXED PRICES

1. Ensure that the designated PLU screen is displayed.

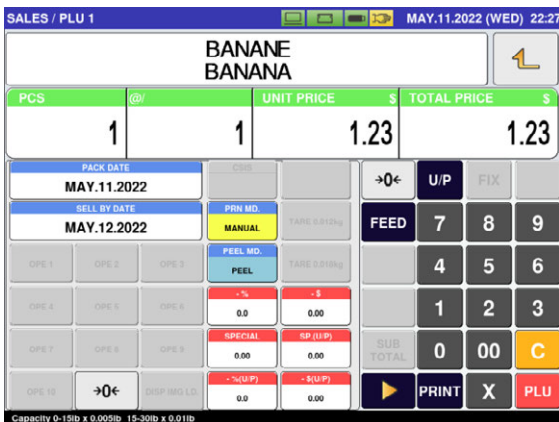

2. Enter the price, and press the "FIXED PRICE" field.

EXAMPLE "\$1.56"

Fixed Price Products

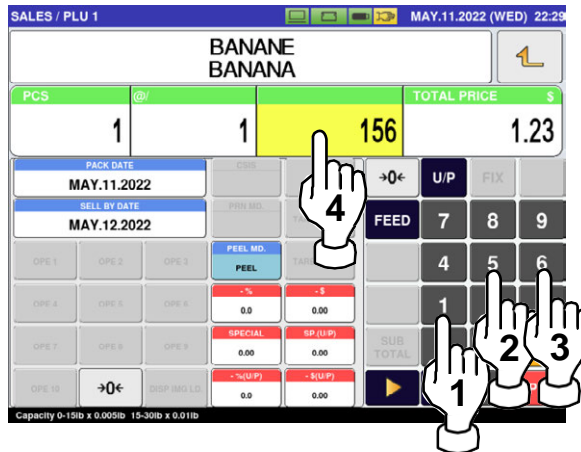

2.3.9 DISCOUNTING UNIT PRICES BY AMOUNT

1. Ensure that the designated PLU screen is displayed.

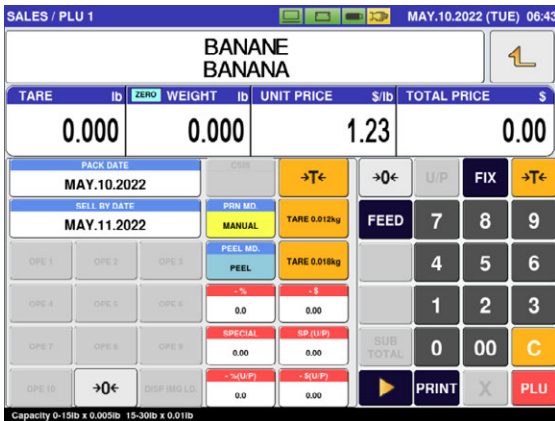

2. Enter the amount to be discounted, and press the "-\$(U/P)" field.

EXAMPLE Discount amount "\$0.50".

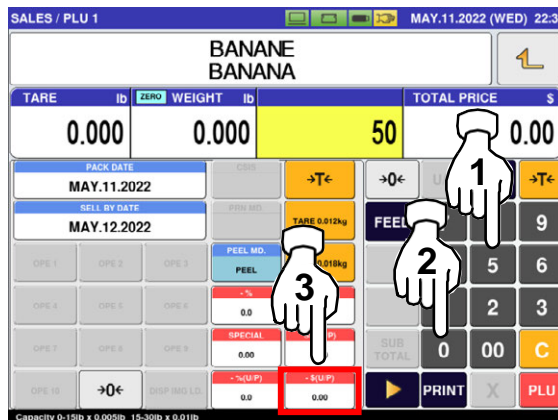

2.3.10 DISCOUNTING UNIT PRICES BY PERCENTAGE

1. Ensure that the designated PLU screen is displayed.

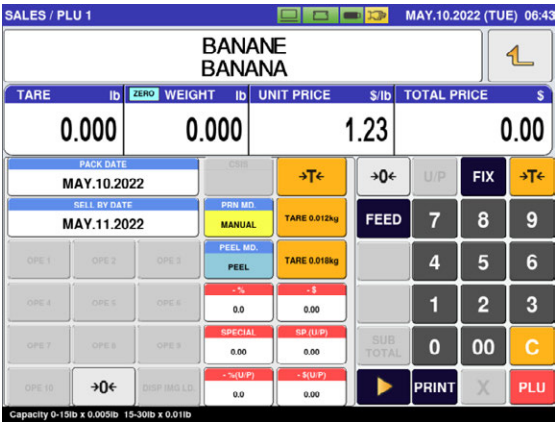

2. Enter the discount percentage, and press the “-% (U/P)” field.

EXAMPLE Discount percentage “10%”.

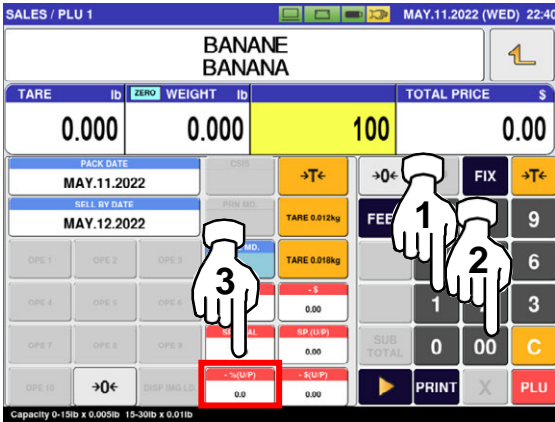

2.3.11 DISCOUNTING TOTAL PRICES BY AMOUNT

1. Ensure that the designated PLU screen is displayed.

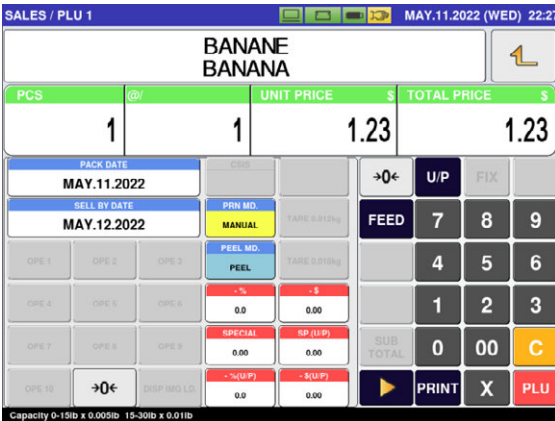

2. Enter a discount amount using the numeric keys, and press the “-\$” field.

EXAMPLE Discount amount “\$0.50”.

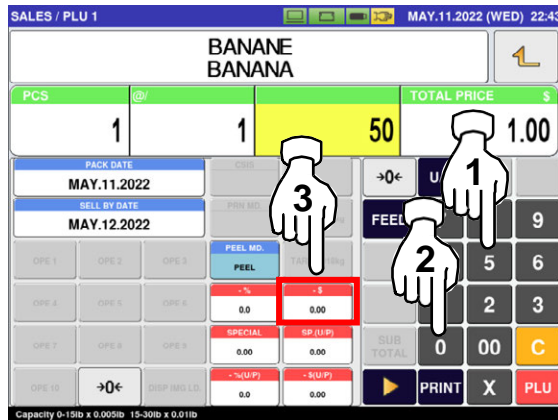

2.3.12 DISCOUNTING TOTAL PRICES BY PERCENTAGE

1. Ensure that the designated PLU screen is displayed.

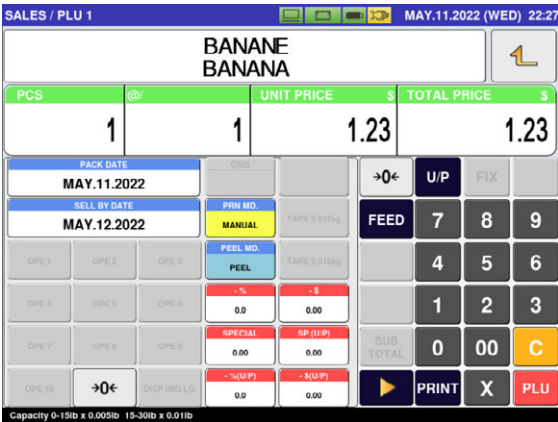

2. Enter the discount percentage, and press the “- %” field.

EXAMPLE Discount percentage “10%”.

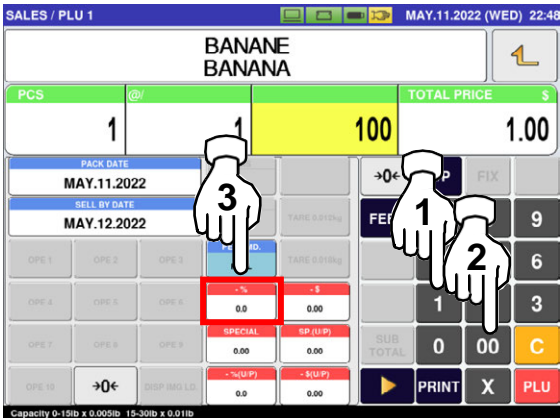

2.3.13 CHANGING QUANTITIES

1. Ensure that the designated price PLU screen is displayed.

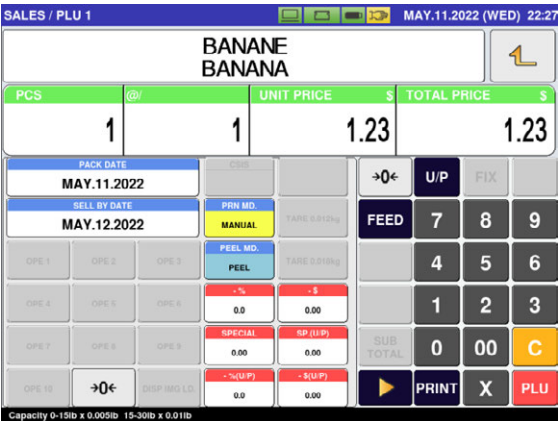

2. Enter the quantity and press the [X] key.

EXAMPLE Quantity “3 pieces”

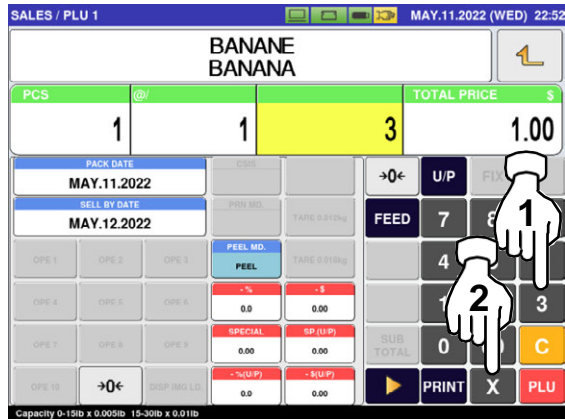

2.3.14 SPECIFYING THE NUMBER OF LABELS

1. Ensure that the designated PLU screen is displayed, and confirm that "AUTO" is selected in the "Print Mode" field.

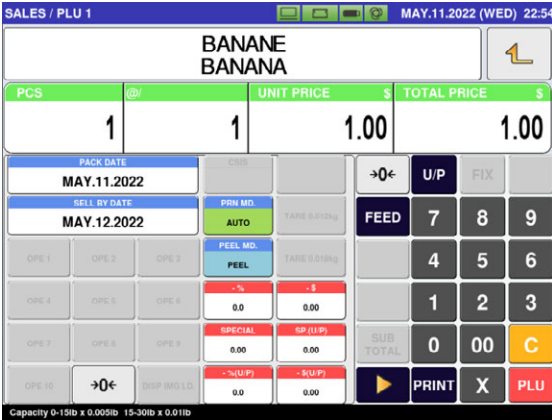

2. Enter the number of labels to be printed and press the [PRINT] key to print labels. .

EXAMPLE "3 labels"

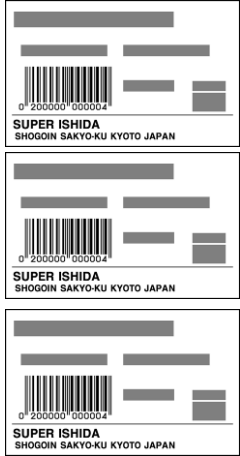
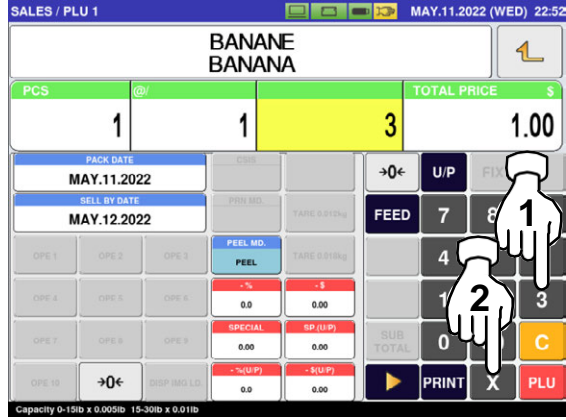

Note: To interrupt the issue of labels, press the [PRINT] key again. To restart the issue of labels, press the [PRINT] key again.

2.3.15 SELF-SERVICE OPERATIONS FOR WEIGHING PRODUCTS

1. Ensure that the initial screen for self-service operations is displayed.

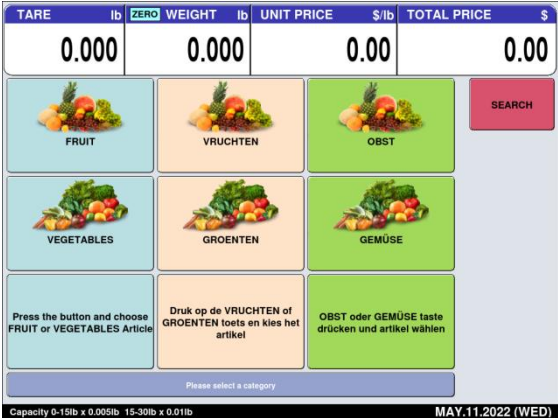

2. Select a product by pressing the corresponding field on the screen.

EXAMPLE "Red Grape" (weighing product)

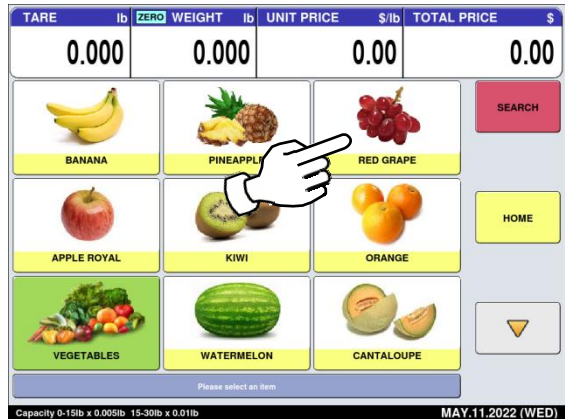

3. The designated product image is displayed.

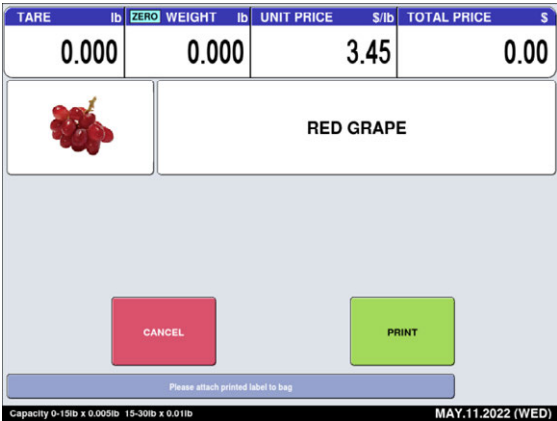

4. Put the product on the weighing platter.



The product is weighed and its total price is calculated.

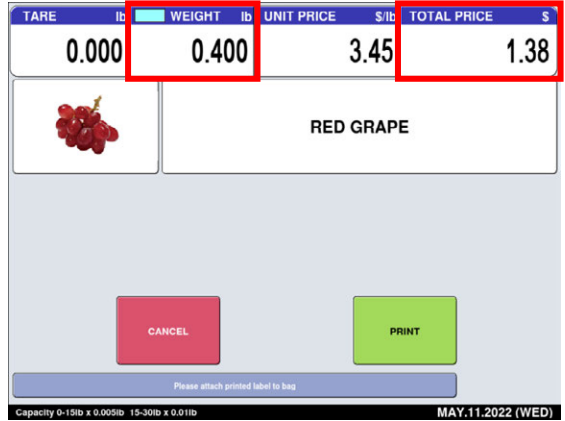

5. Press the [PRINT] button to issue a label.

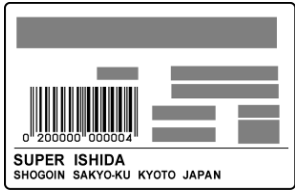
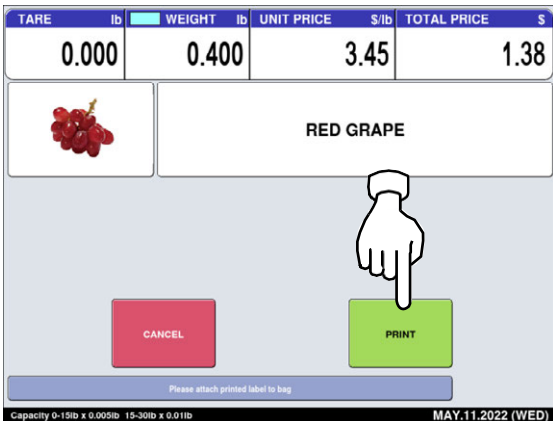

2.3.16 SELF-SERVICE OPERATIONS FOR FIXED PRICE PRODUCTS

1. Ensure that the initial screen for self-service operations is displayed.

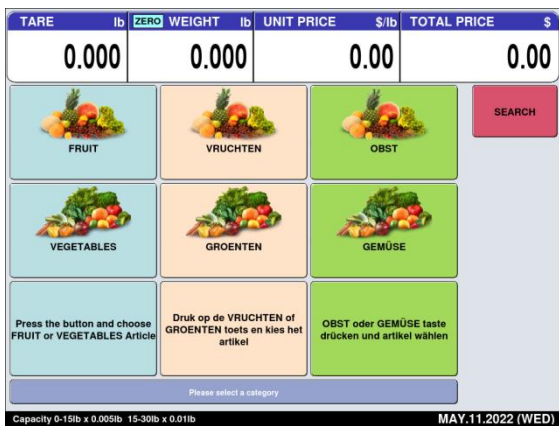

2. Select a product by pressing the corresponding field on the screen.

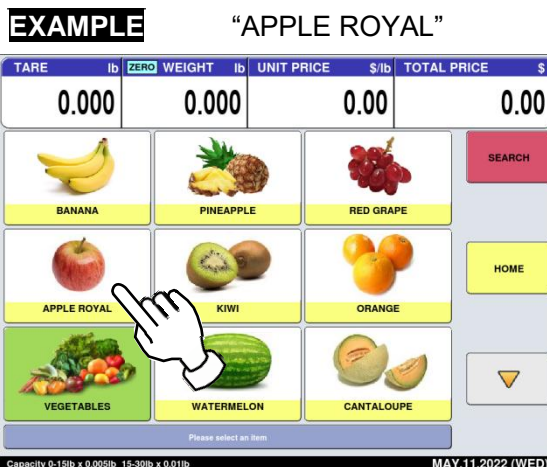

3. The designated product image is displayed.

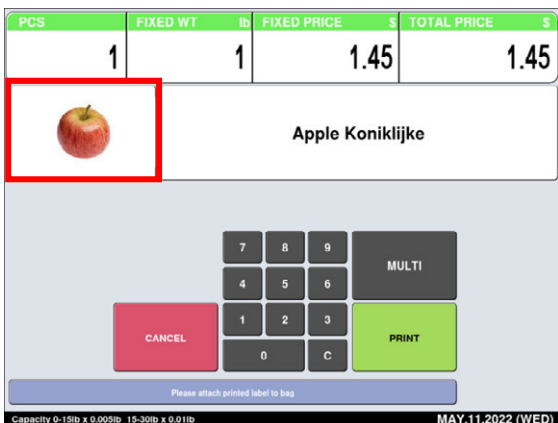

Enter the quantity and press the [MULTI] key. Then, press the [PRINT] key to issue a label.

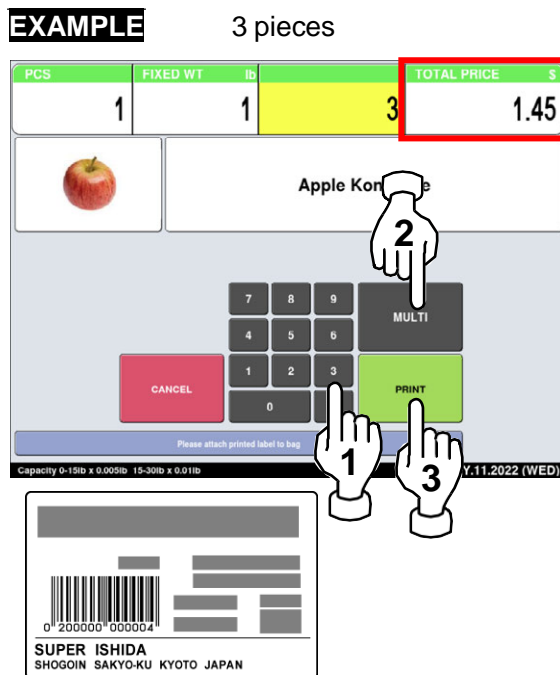

	12.1 / 10.1 inch Display	10.1 inch
	<p>12.1 inch</p>	<p>10.1 inch</p>
	<p>Capacity 0-15lb x 0.005lb 15-30lb x 0.01lb</p> <p>MAY.11.2022 (WED)</p>	<p>Capacity 0-15lb x 0.005lb 15-30lb x 0.01lb</p> <p>MAY.11.2022 (WED)</p>

2.3.17 ACCUMULATIONS THROUGH MANUAL ENTRY

1. Ensure that the operation menu selection screen is displayed. Then, press the "ACC (Accumulation)" icon.

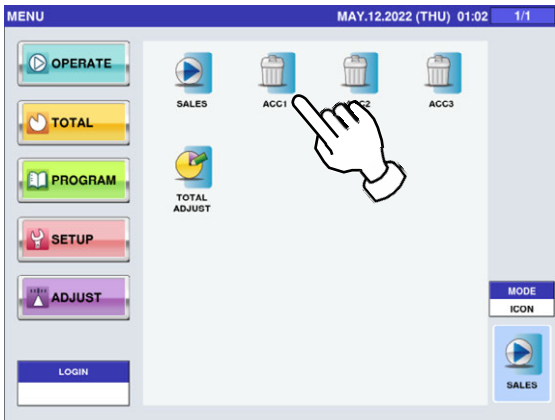

The "Input Numerical Accumulation" screen is displayed.

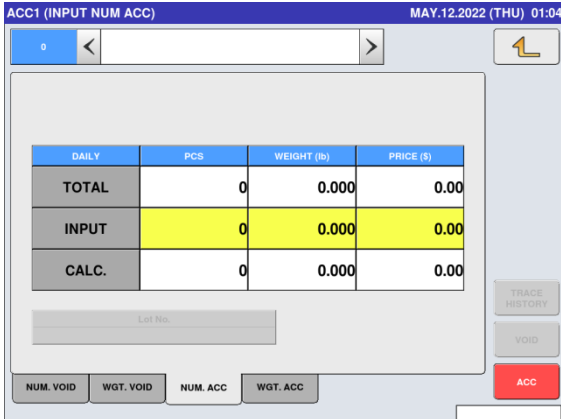

2. Press the input field at the right-bottom of the screen to display the keypad. Then, enter a PLU number and press the [PLU] key on the keypad.

EXAMPLE PLU No.3

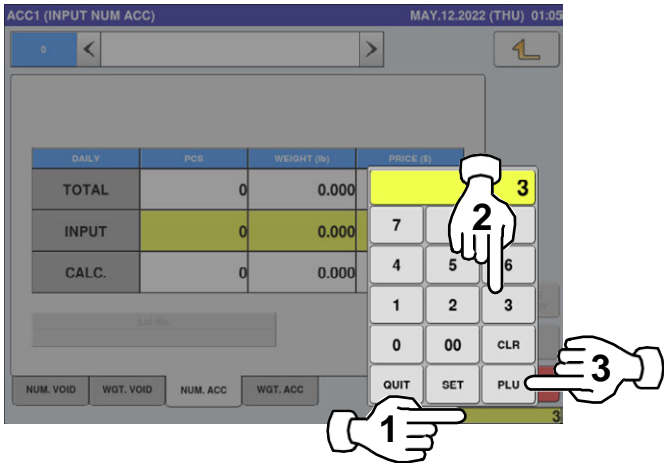

The "Input Numerical Accumulation" screen for the designated product is displayed.

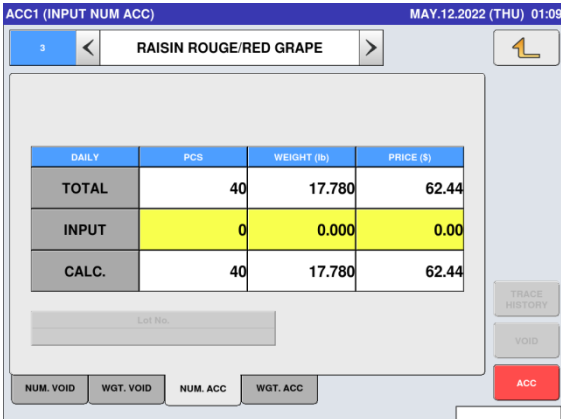

3. Enter the quantity, weight, and price to be accumulated and press the applicable fields. Then, press the [ACC] button on the screen.

EXAMPLE Quantity "1 pc.", Weight "400g", Price "\$1.50"

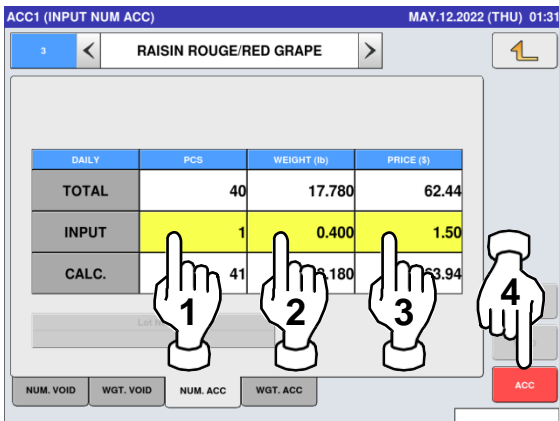

4. The confirmation screen is displayed. Press [EXEC] to continue, or [STOP] to go back.

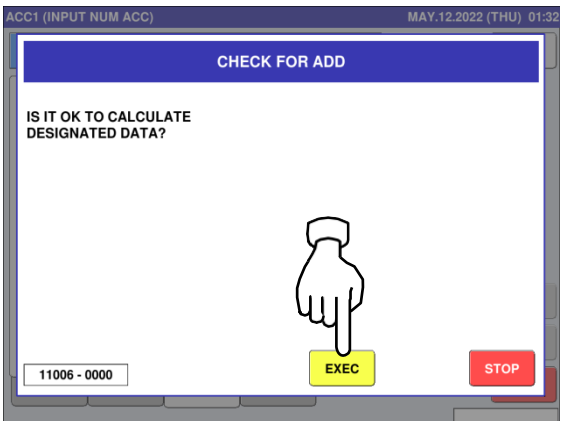

5. The accumulation procedure has been completed.

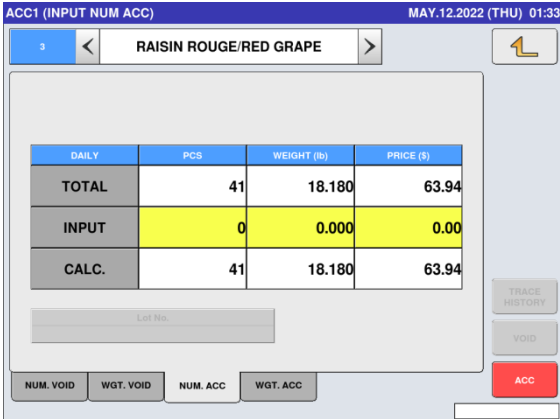

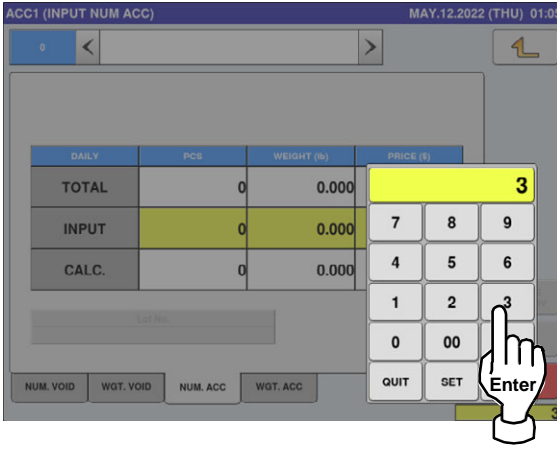
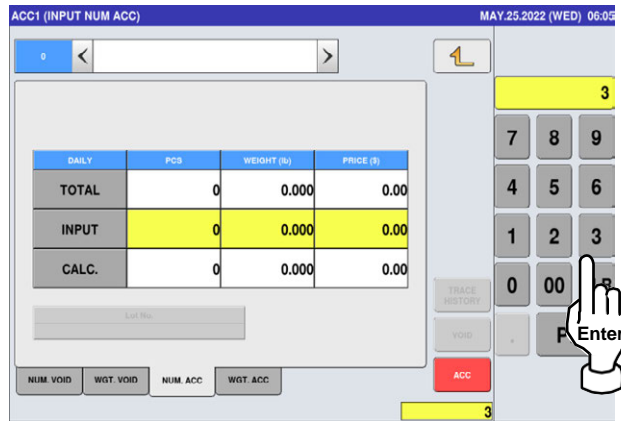
 INFOR	12.1 / 10.1 inch Display	
	12.1 inch	10.1 inch
		

2.3.18 ACCUMULATIONS THROUGH WEIGHING PRODUCTS

1. Ensure that the operation menu selection screen is displayed. Then, press the "ACC (Accumulation)" icon.

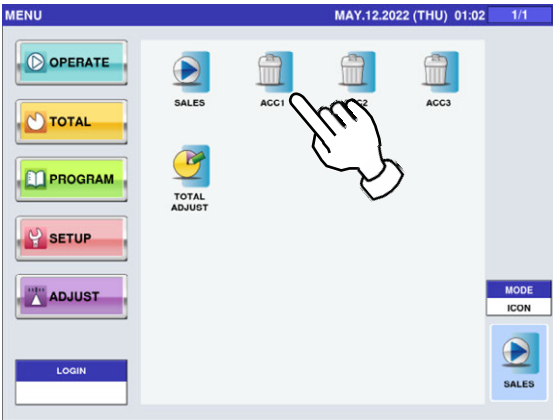

➔ The "Input Numerical Accumulation" screen is displayed.



2. Press the "WGT. ACC" tab to display the "Weighing Accumulation" screen.

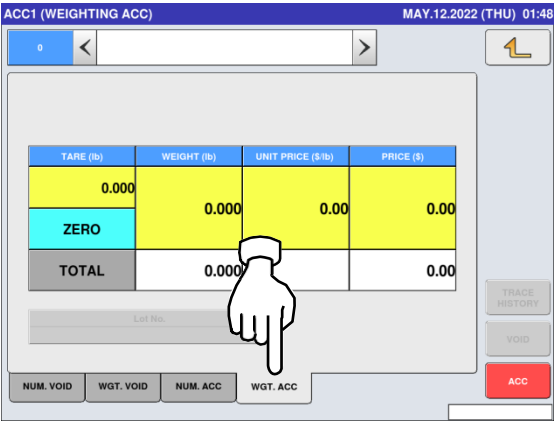

3. Press the input field at the right-bottom of the screen to display the keypad. Then, enter a PLU number and press the [PLU] key on the keypad.

EXAMPLE PLU No.3

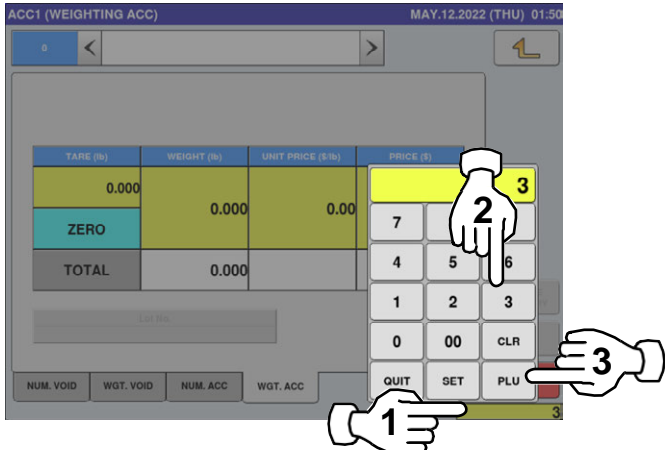

➔ The Weighing Accumulation screen for the designated product is displayed.

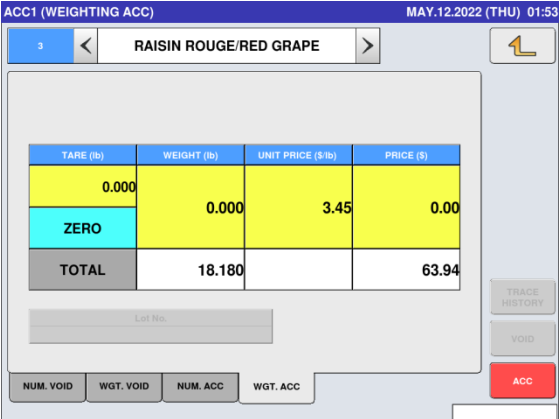

4. Put the product on the weighing platter and press the [ACC] button.

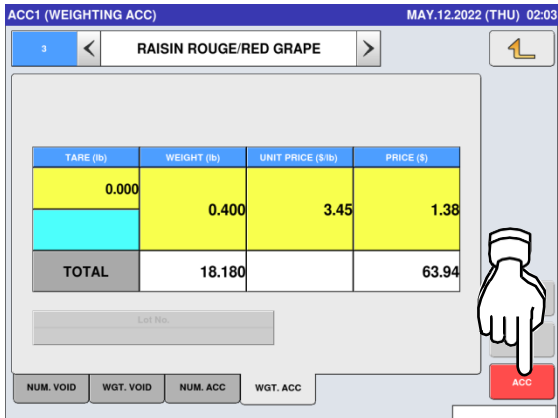

- 5. The confirmation screen is displayed.
Press [EXEC] to continue, or [STOP] to go back.

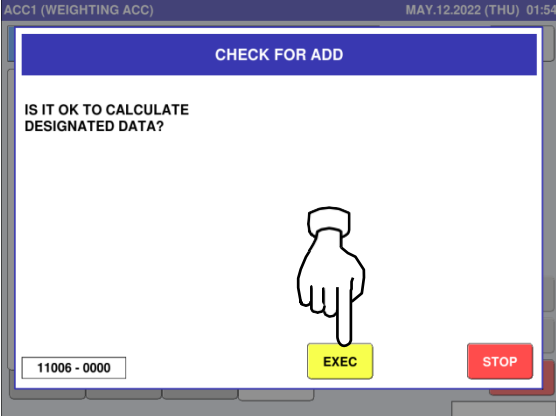

- 6. Remove the product from the weighing platter.
The accumulation procedure has been completed.

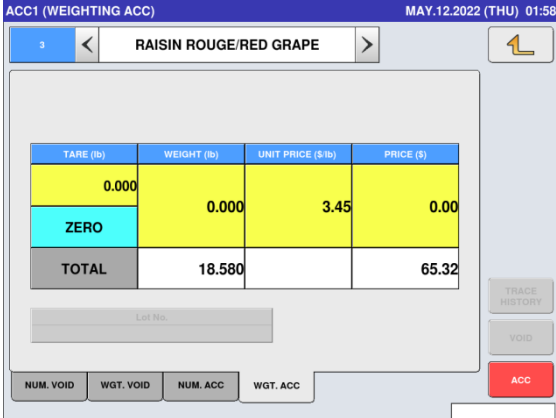

2.3.19 VOIDING REGISTRATIONS THROUGH MANUAL ENTRY

- 1. Ensure that the operation menu selection screen is displayed. Then, press the “ACC (Accumulation)” icon.

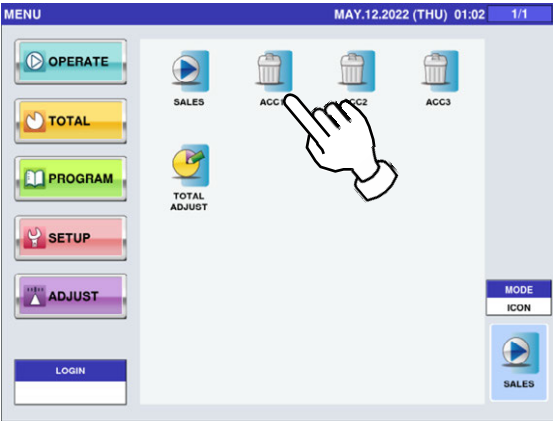

➔ The “Input Numerical Accumulation” screen is displayed.

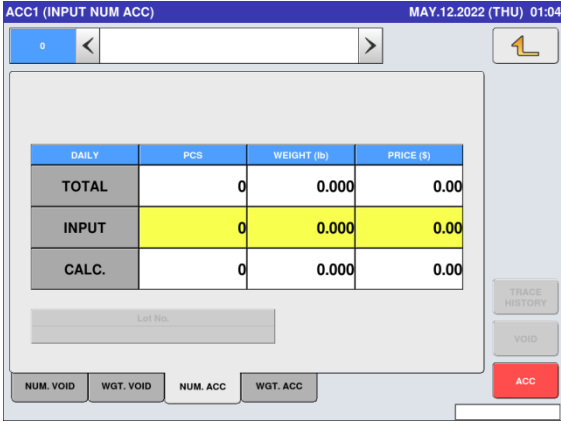

- 2. Press the “NUM. VOID” tab to display the “Input Number Void” screen.

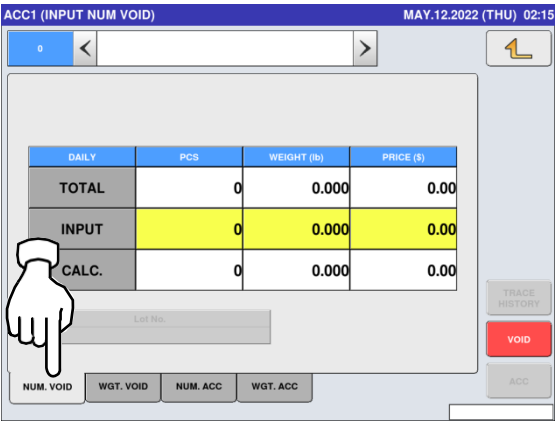

- 3. Press the input field at the right-bottom of the screen to display the keypad. Then, enter a PLU number and press the [PLU] key on the keypad.

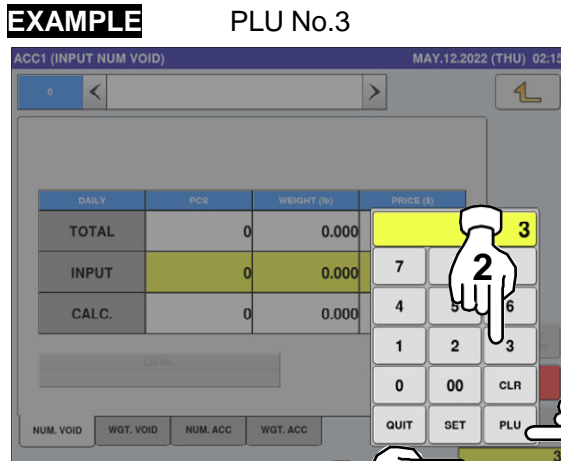

➔ The “Input Number Void” screen for the selected product is displayed.

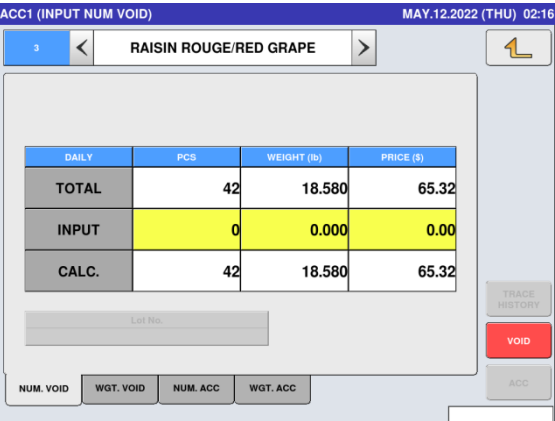

- 4. Enter the quantity, weight, and price to be voided and press the applicable fields. Then, press the [VOID] button.

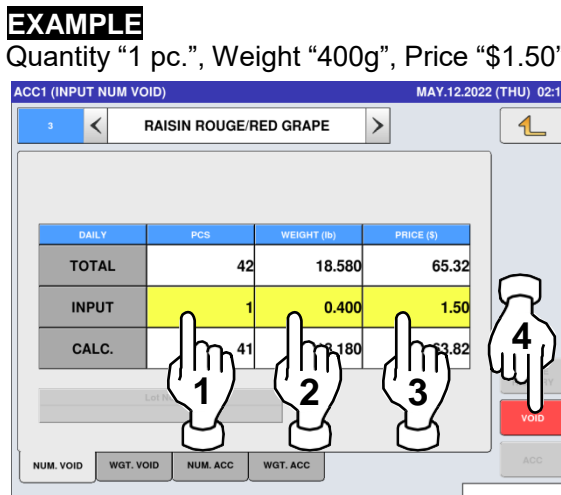

- 5. The confirmation screen is displayed. Press [EXEC] to continue, or [STOP] to go back.

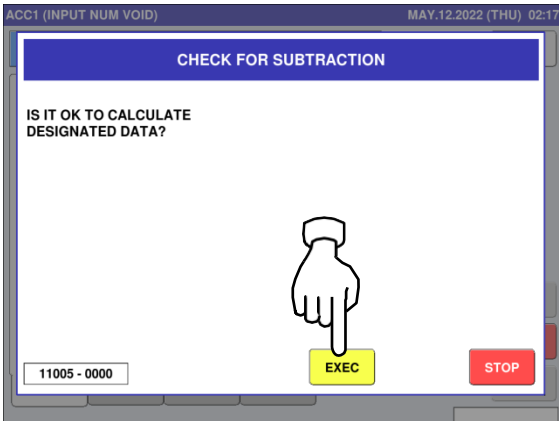

- 6. The void procedure has been completed.

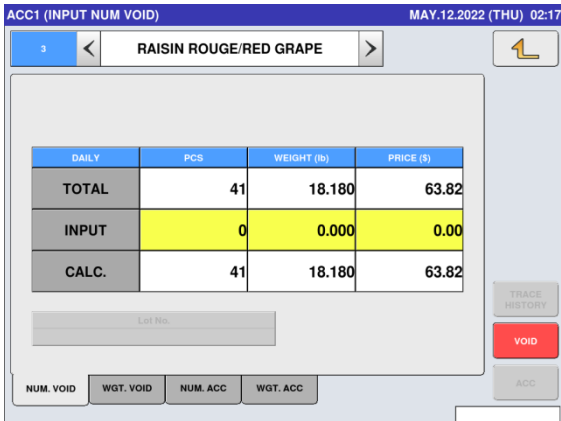

2.3.20 VOIDING THROUGH WEIGHING PRODUCTS

1. Press the "ACC (Accumulator)" icon.

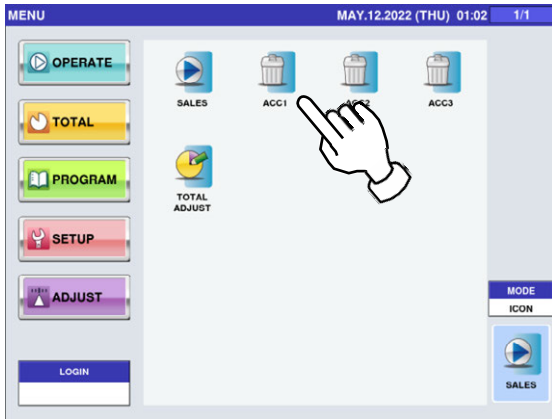

- ➔ The "Input Number Accumulation" screen is displayed.

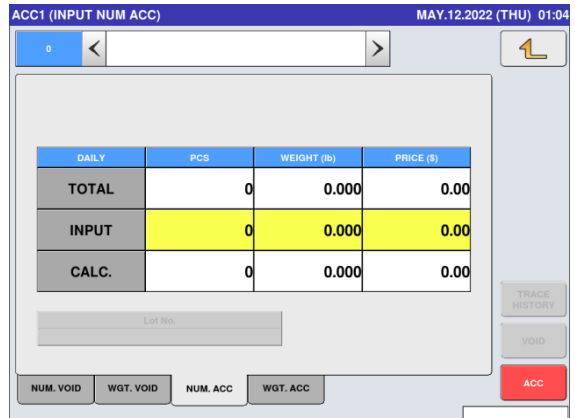

2. To display the "Weighing Void" screen, press the "WGT. VOID" tab.

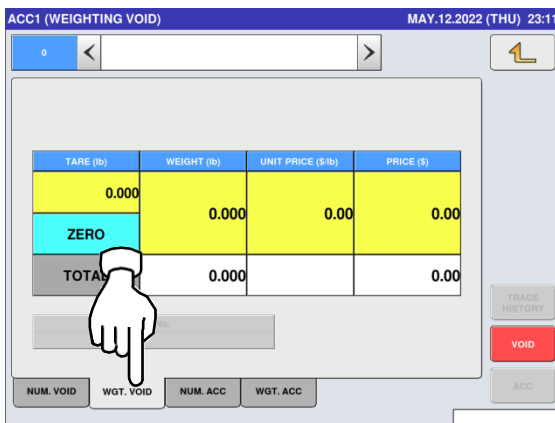

3. Press the input field at the right-bottom of the screen to display the keypad. Then, enter a PLU number and press the [PLU] key on the keypad.

EXAMPLE PLU No.3

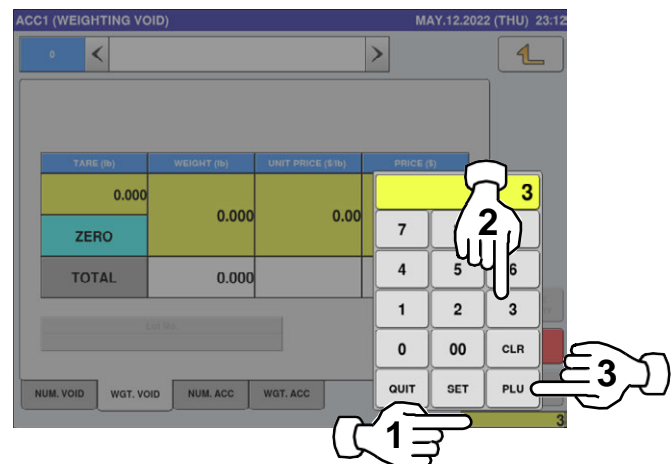

- ➔ The "Weighing Void" screen for the selected product is displayed.

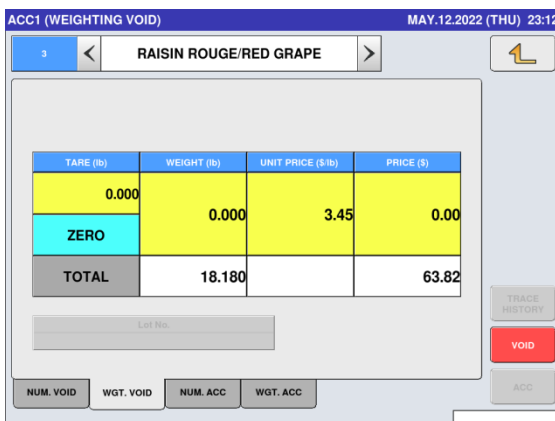

4. Put the product on the weighing platter and press the [VOID] button on the screen.

PRODUCT

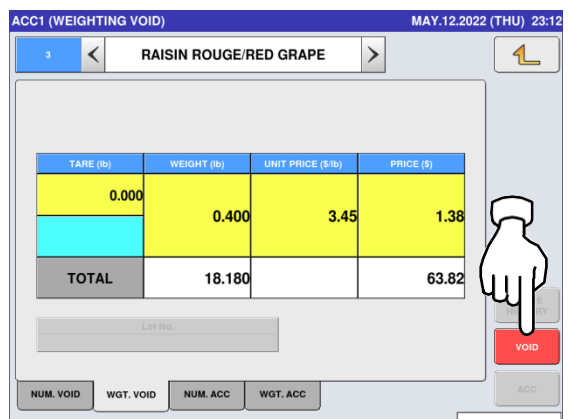

- 5. The confirmation screen is displayed.
Press [EXEC] to continue, or [STOP] to go back.

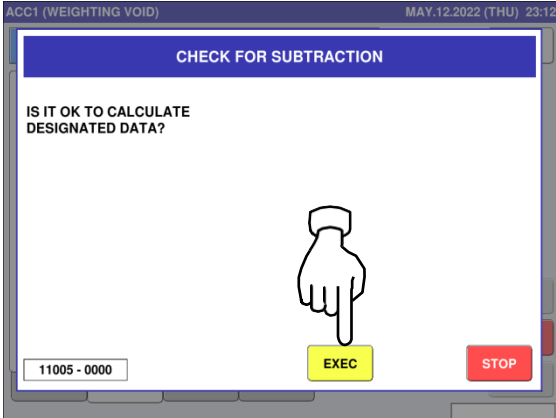

- 6. Remove the product from the weighing platter.
The void procedure has been completed.

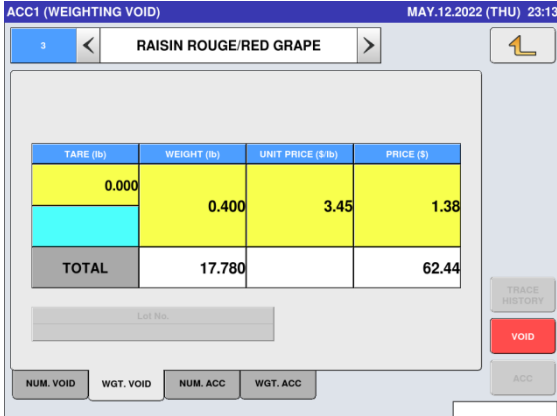

2.3.21 SUBTRACTING TOTALS THROUGH MANUAL ENTRY

Press the "TOTAL ADJUST" icon.

1.

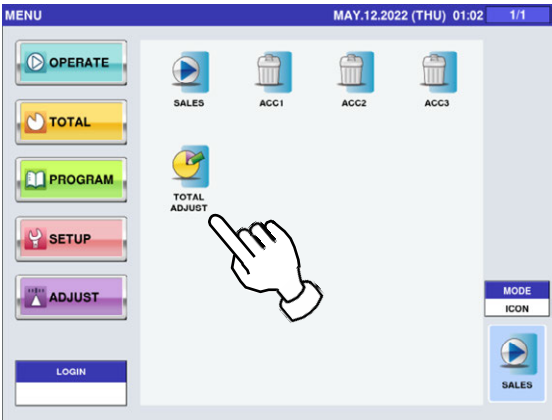

The "Total Adjust (Input Number Subtraction)" screen is displayed.

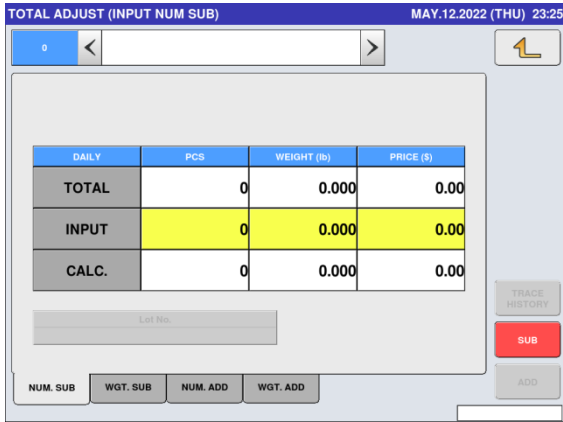

2.

Press the input field at the right-bottom of the screen to display the keypad. Then, enter a PLU number and press the [PLU] key on the keypad.

EXAMPLE PLU No.3

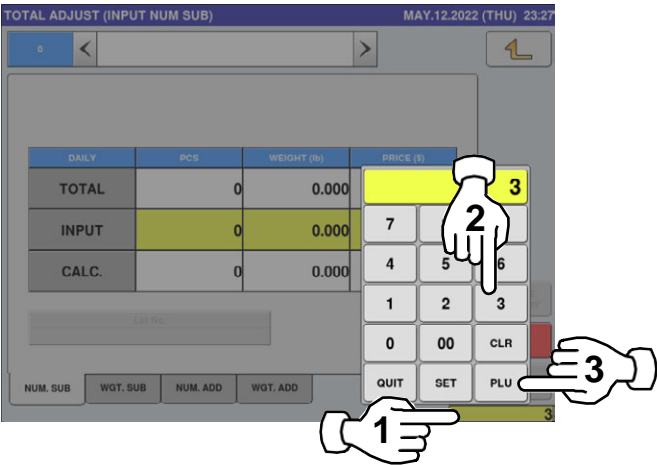

The Total Adjust (Input Number Subtraction) screen for the selected product is displayed.

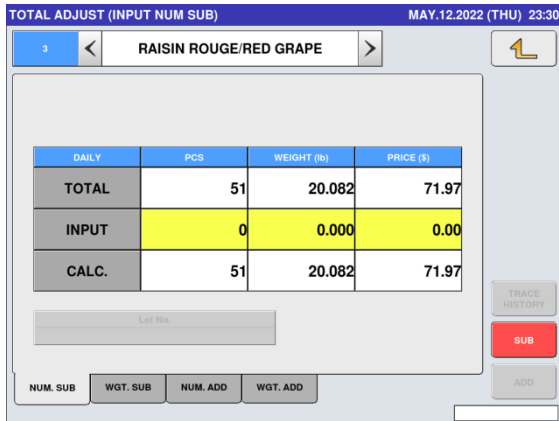

3.

Enter the quantity, weight, and price to be subtracted and press the applicable fields. Then, press the [SUB] button on the screen.

EXAMPLE

Quantity "1 pc.", Weight "400g", Price "\$1.50"

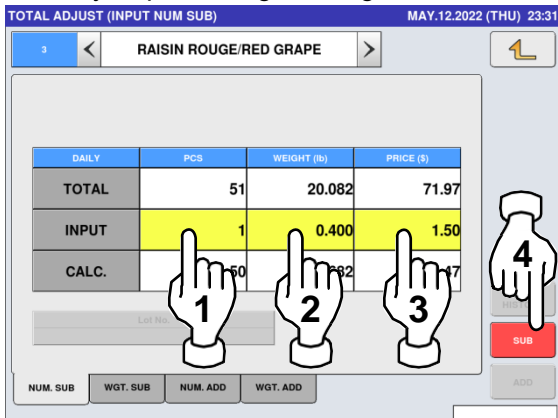

4.

The confirmation screen is displayed. Press [EXEC] to continue, or [STOP] to go back.

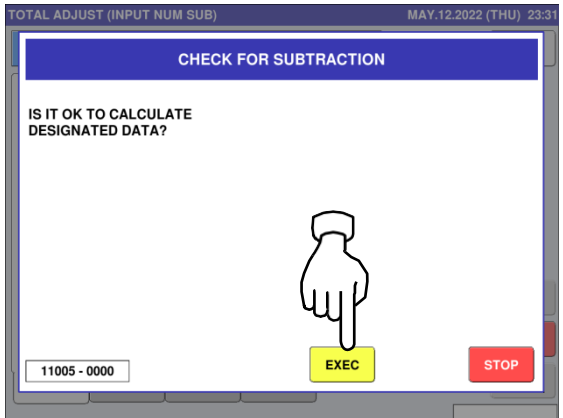

5. The subtraction procedure has been completed.

TOTAL ADJUST (INPUT NUM SUB) MAY.12.2022 (THU) 23:31

1 < RAISIN ROUGE/RED GRAPE > 

DAILY	PCS	WEIGHT (lb)	PRICE (\$)
TOTAL	50	19.682	70.47
INPUT	0	0.000	0.00
CALC.	50	19.682	70.47

Lot No.

TRACE HISTORY

SUB

ADD

NUM. SUB WGT. SUB NUM. ADD WGT. ADD

2.3.22 SUBTRACTING TOTALS THROUGH WEIGHING PRODUCTS

Press the "TOTAL ADJUST" icon.

1.

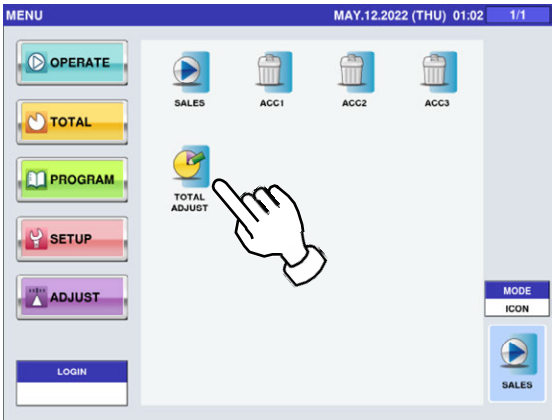

The "Total Adjust (Input Number Subtraction)" screen is displayed.

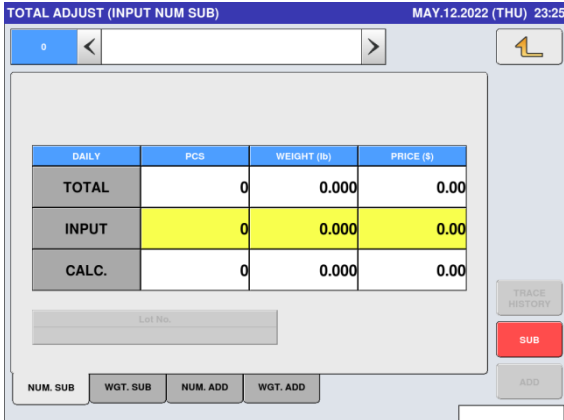

To display the "Total Adjust (Weighing Subtraction)" screen, press the "WGT. SUB" tab.

2.

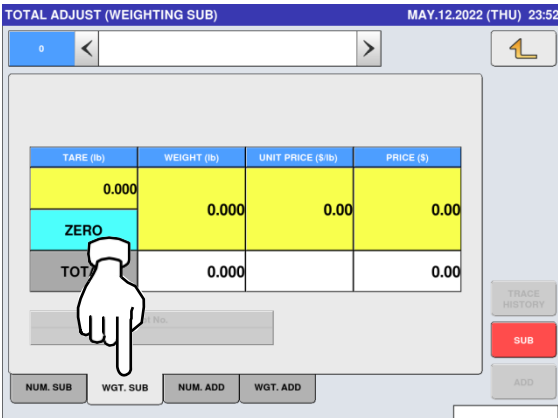

Press the input field at the right-bottom of the screen to display the keypad. Then, enter a PLU number and press the [PLU] key on the keypad.

3.

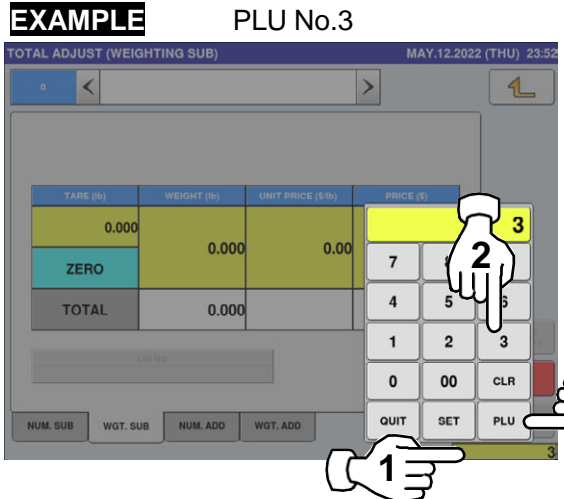

The "Total Adjust (Weighing Subtraction)" screen for the selected product is displayed.



Put the product on the weighing platter and press the [SUB] button.

4.

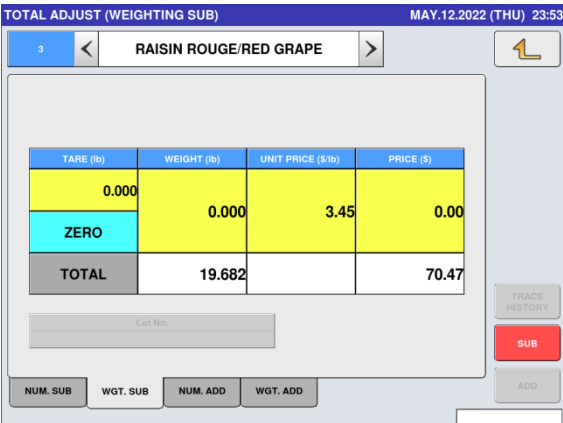

PRODUCT

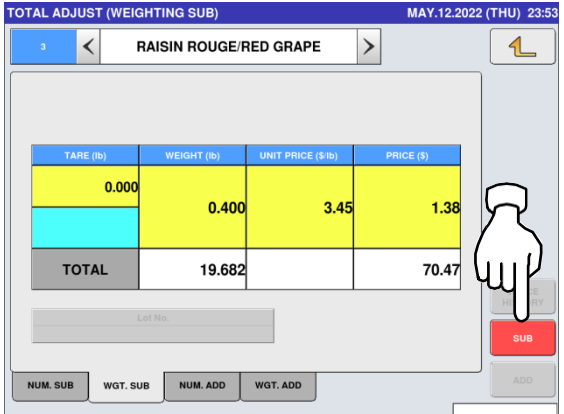

- 5. The confirmation screen is displayed. Press [EXEC] to continue, or [STOP] to go back.

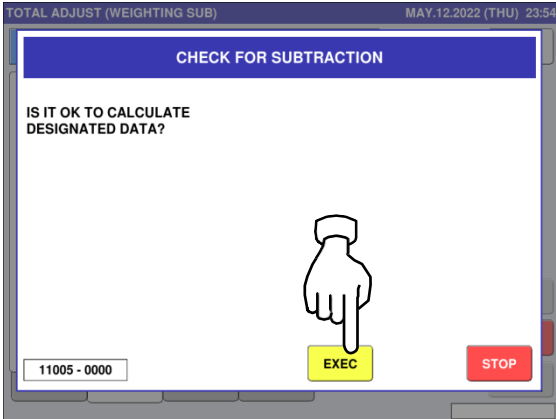

- 6. Remove the product from the weighing platter to complete the subtraction procedure.

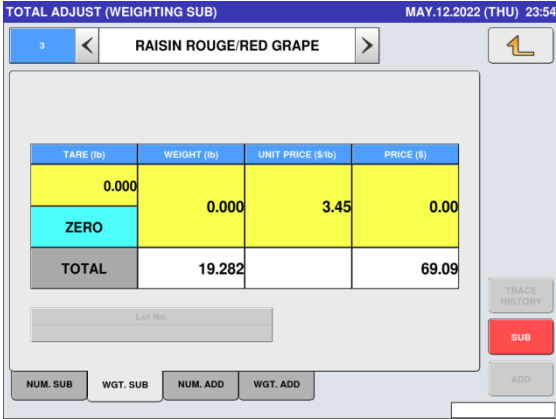

2.3.23 ADDING TOTALS THROUGH MANUAL ENTRY

Press the "TOTAL ADJUST" icon.

1.

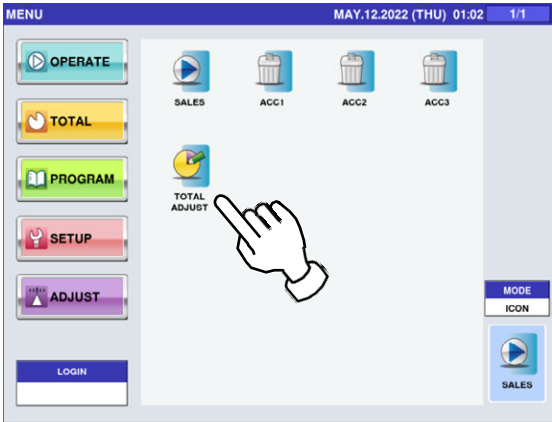

The "Total Adjust (Input Number Subtraction)" screen is displayed.

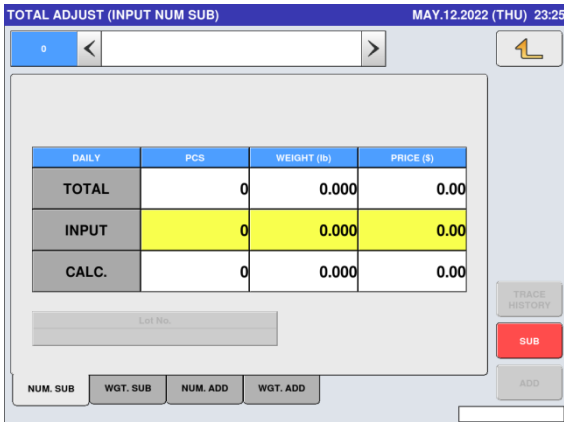

To display the "Total Adjust (Input Number Addition)" screen, press the "NUM. ADD" tab.

2.

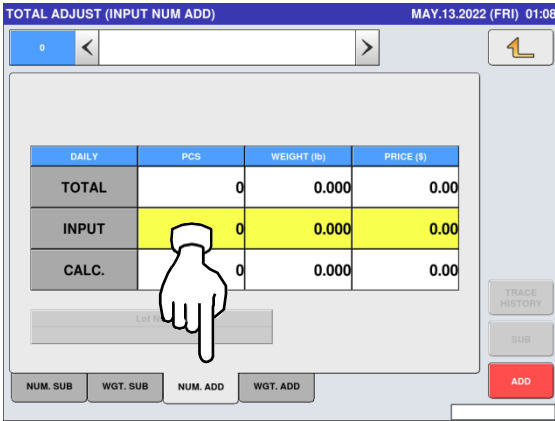

3.

Press the input field at the right-bottom of the screen to display the keypad. Then, enter a PLU number and press the [PLU] key on the keypad.

EXAMPLE

PLU No.3

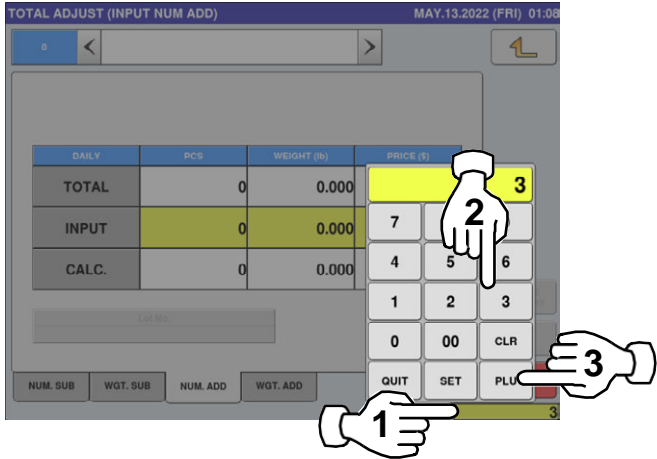

The "Total Adjust (Input Number Addition)" screen for the selected product is displayed.



4.

Enter the quantity, weight, and price to be added and press the applicable fields. Then, press the [ADD] button.

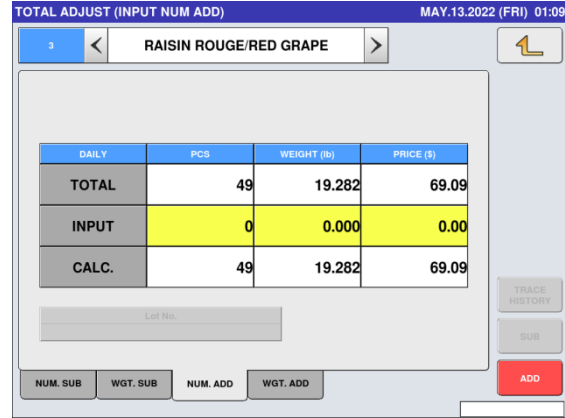

EXAMPLE

Quantity "1 pc.", Weight "400g", Price "\$1.50"

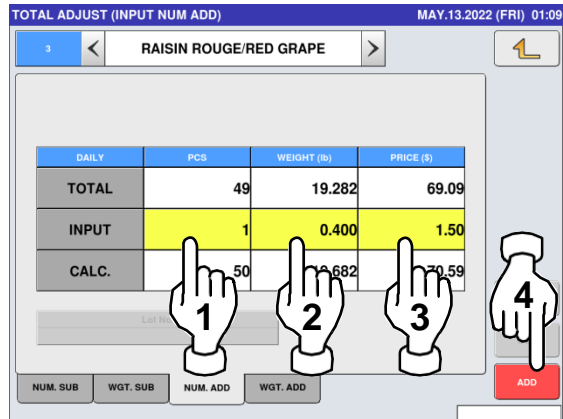

5. The confirmation screen is displayed. Press [EXEC] to continue, or [STOP] to go back.

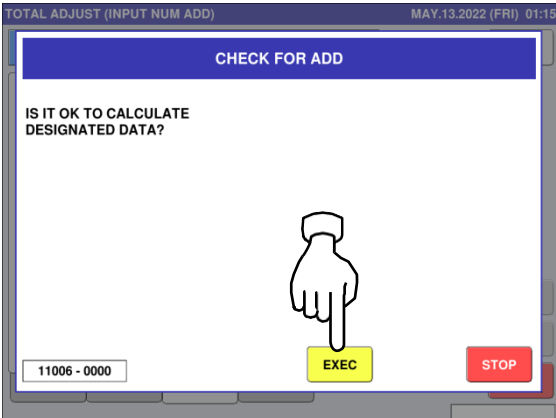

6. The addition procedure has been completed.

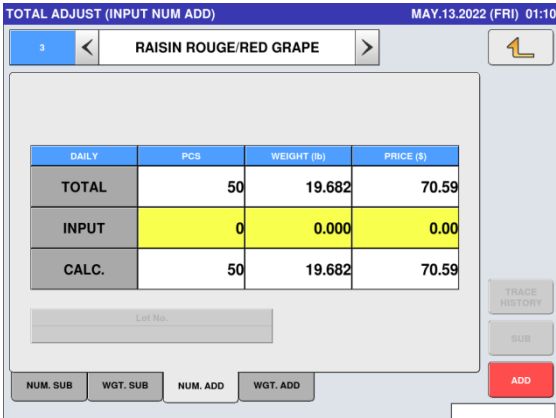

2.3.24 ADDING TOTALS THROUGH WEIGHING PRODUCTS

1. Press the "TOTAL ADJUST" icon.

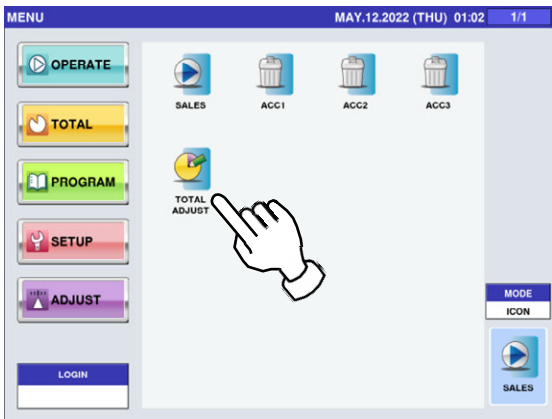

- ➔ The "Total Adjust (Input Number Subtraction)" screen is displayed.

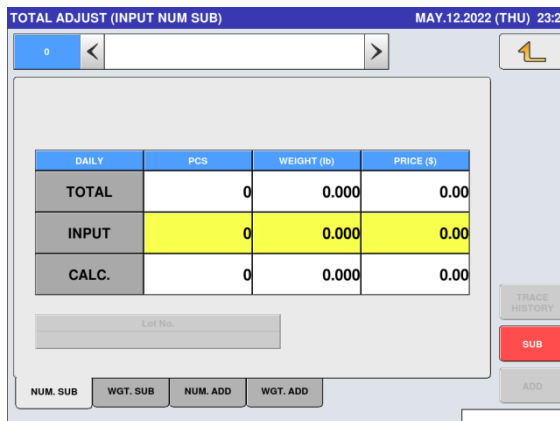

2. To display the "Total Adjust (Weighing Add)" screen, press the [WGT. ADD] tab.

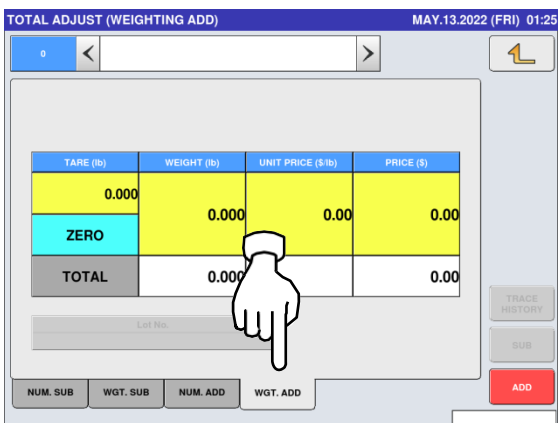

3. Press the input field at the right-bottom of the screen to display the keypad. Then, enter a PLU number and press the [PLU] key on the keypad.

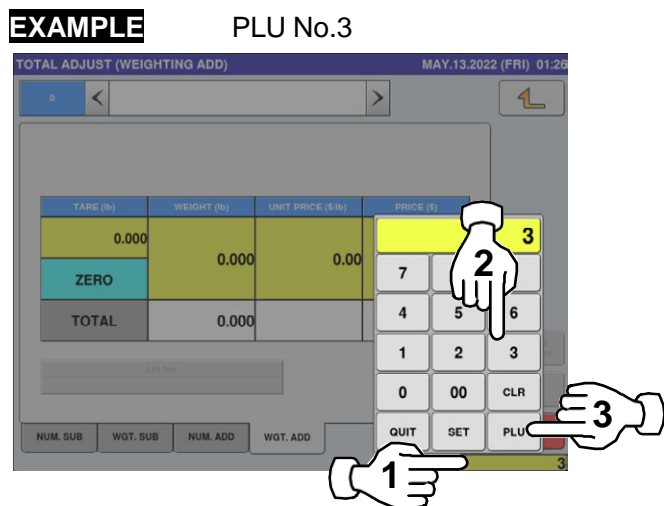

- ➔ The "Total Adjust (Weighing Add)" screen for the selected product is displayed.

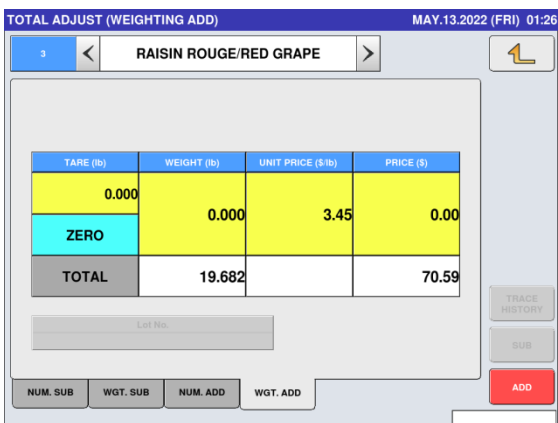

4. Put the product on the weighing platter and press the [ADD] button.

PRODUCT

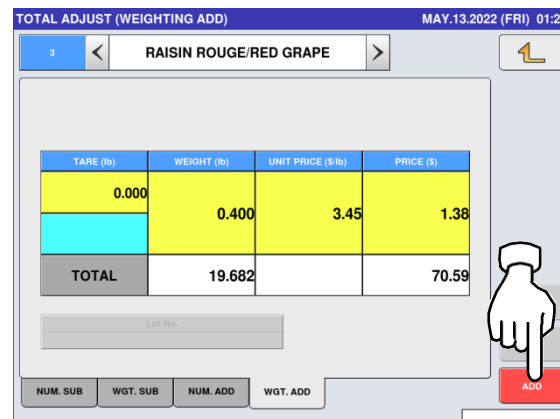

- 5. The confirmation screen is displayed. Press [EXEC] to continue, or [STOP] to go back.

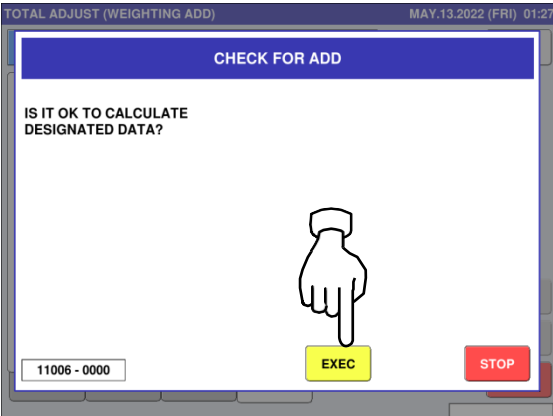

- 6. Remove the product from the weighing platter to complete the addition procedure.



TOTAL MODE

3.1 TOTAL MODE ENTRY / EXIT

1. Make sure that the initial screen is displayed. Then, press the Return button on the screen to display the "Menu" screen.
2. Press the [TOTAL] button.

Note: The contents of the initial screen may differ depending on the settings on your machine.

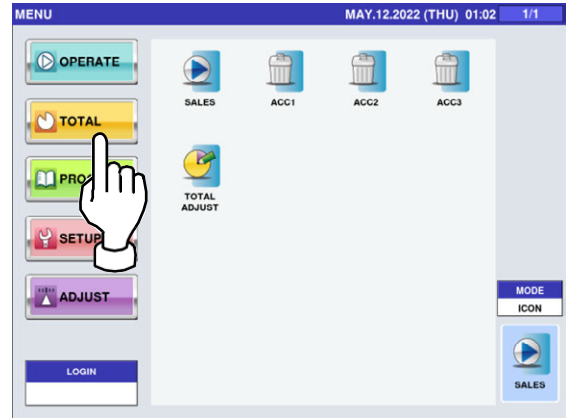
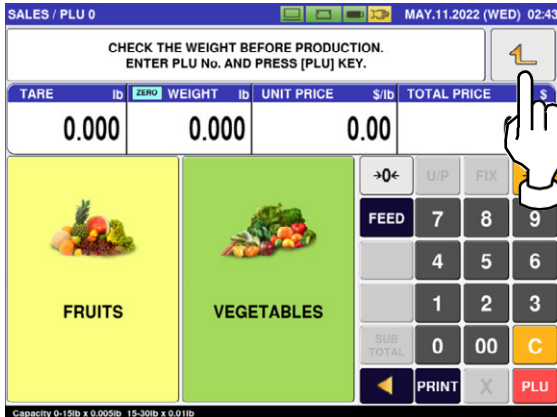

➔ The total menu selection screen is displayed.

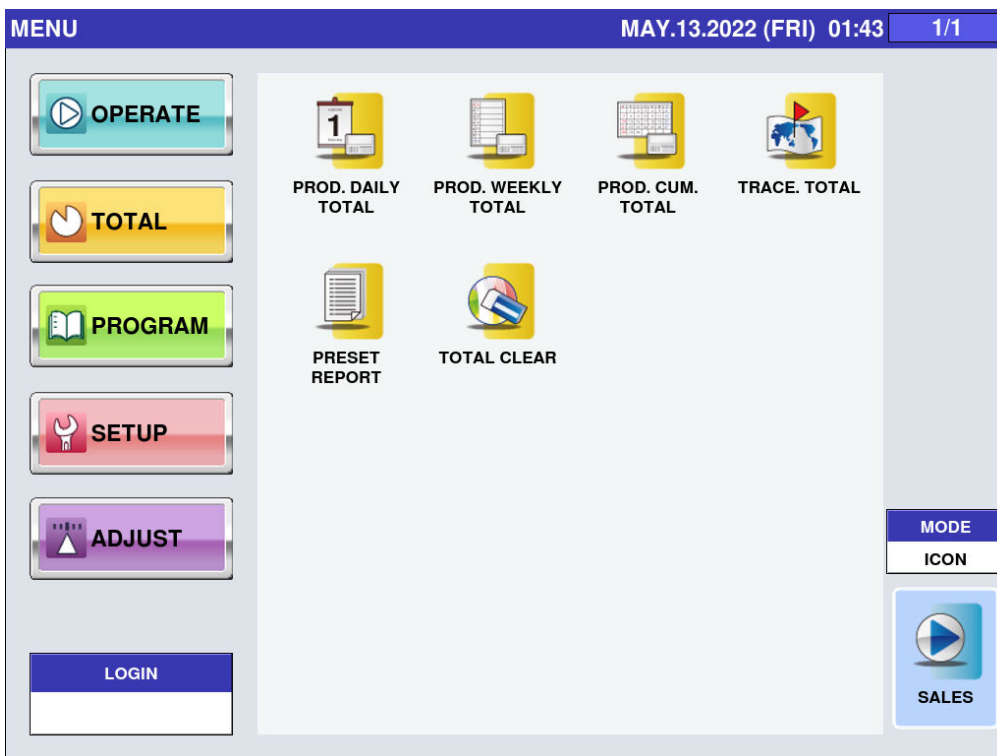

Note: To exit the Total Mode, press the [SALES] button.

3.2 DAILY TOTALS

1. The total menu selection screen is displayed.

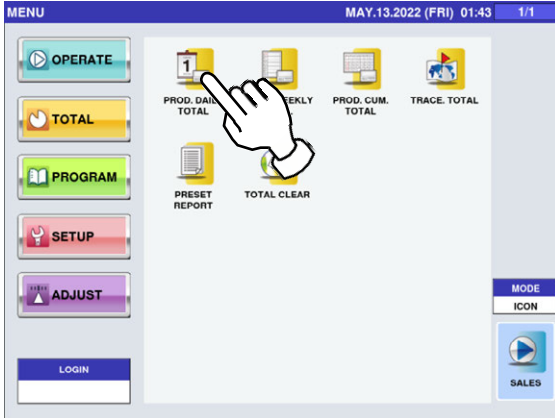

- ➔ The “Production Daily Total (Total)” screen is displayed.

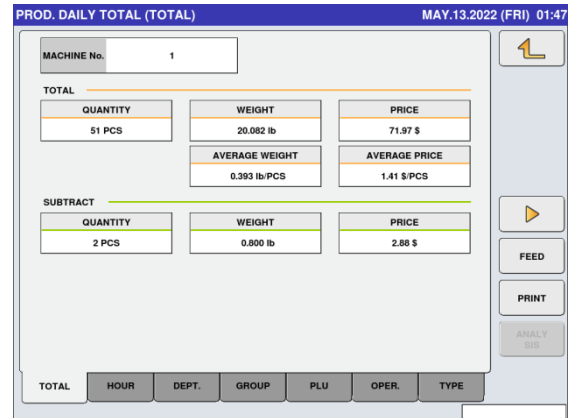

2. To display the “Production Daily Total (Hourly)” screen, press the “HOUR” tab. To turn pages, press [▼] or [▲].

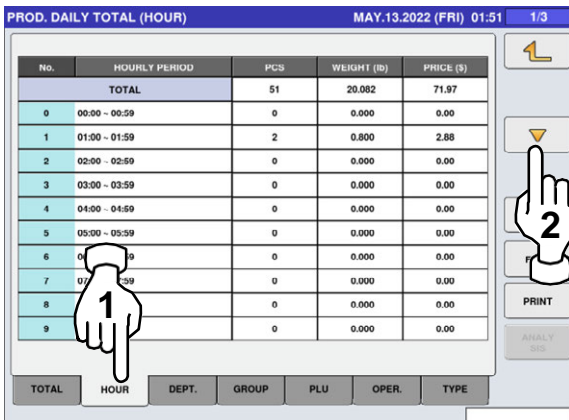

3. To display the “Production Daily Total (Department)” screen, press the “DEPT.” tab.

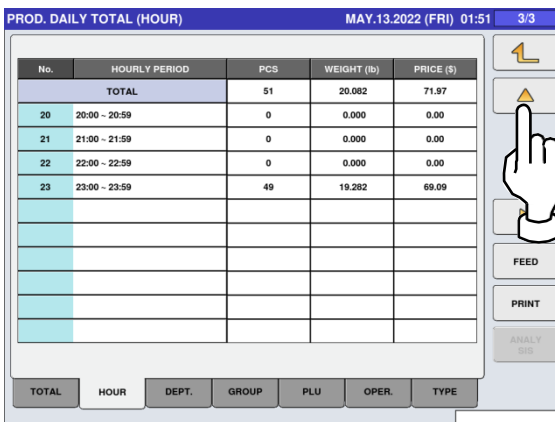
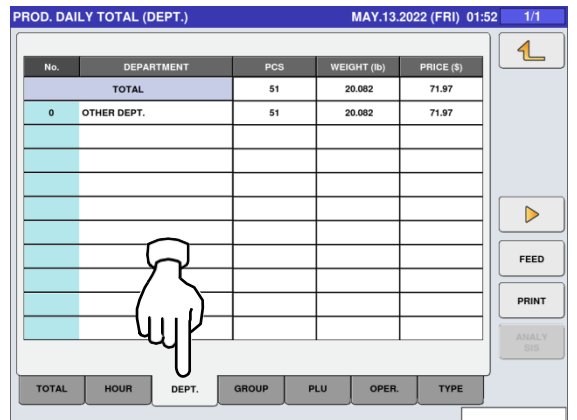

4. To display the “Production Daily Total (Group)” screen, press the “GROUP” tab.

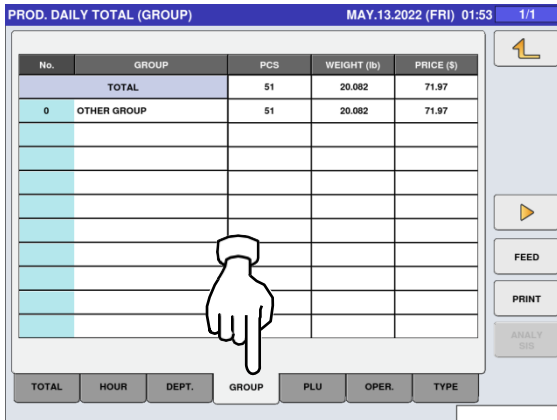

5. To display the “Production Daily Total (PLU)” screen, press the “PLU” tab.

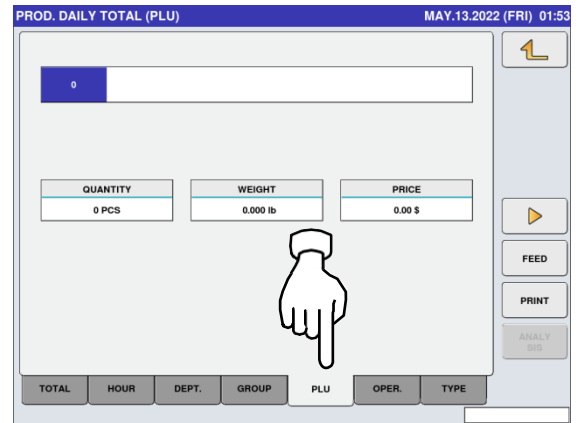

6. Press the input field at the right-bottom of the screen to display the keypad. Then, enter a desired PLU number and press the [PLU] key on the keypad.

EXAMPLE PLU No.3

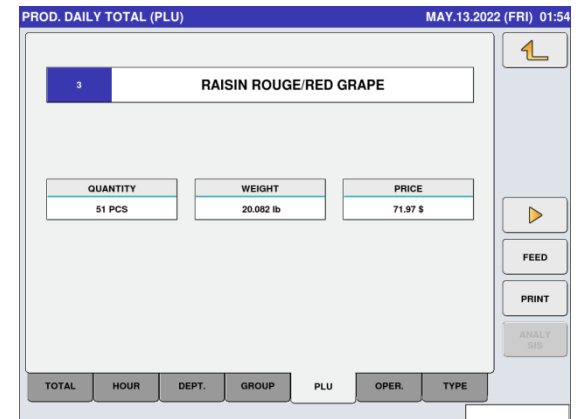
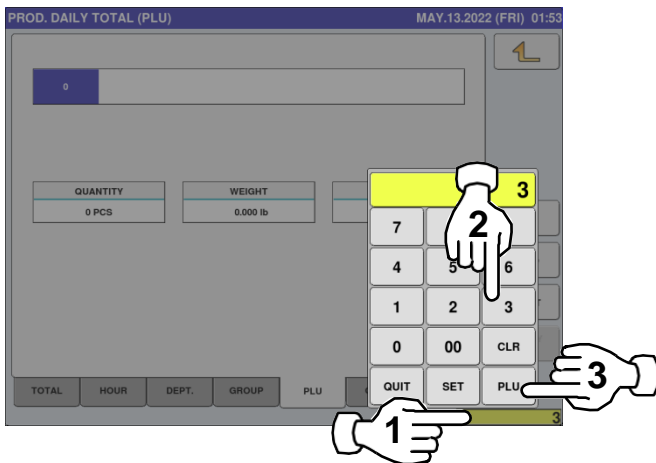

7. To display the “Production Daily Total (Operator)” screen, press the “OPER.” tab.

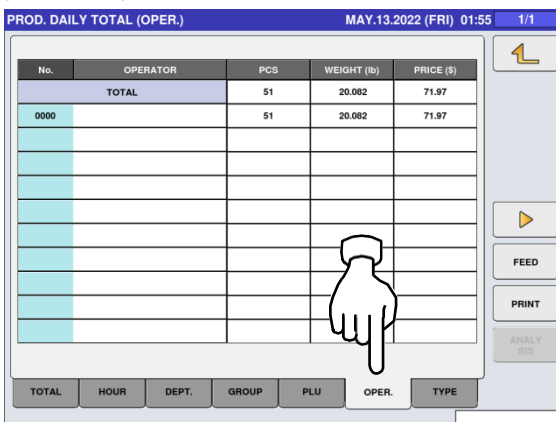

8. To display the “Production Daily Total (Type)” screen, press the “TYPE” tab.

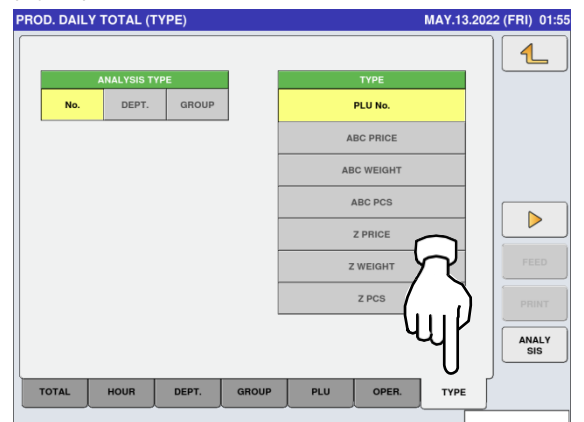

9. Select the target reports by pressing a desired button.

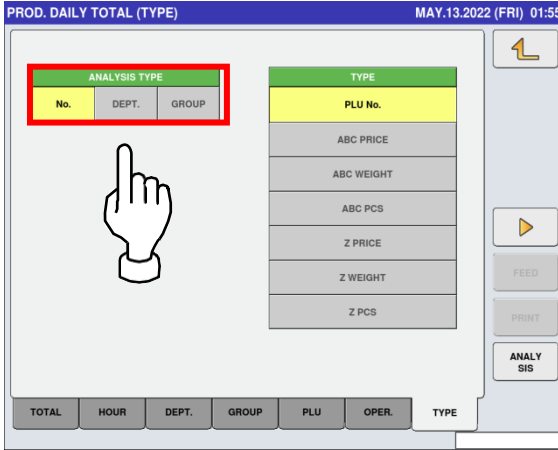

10. Select the listing order by pressing a desired button.

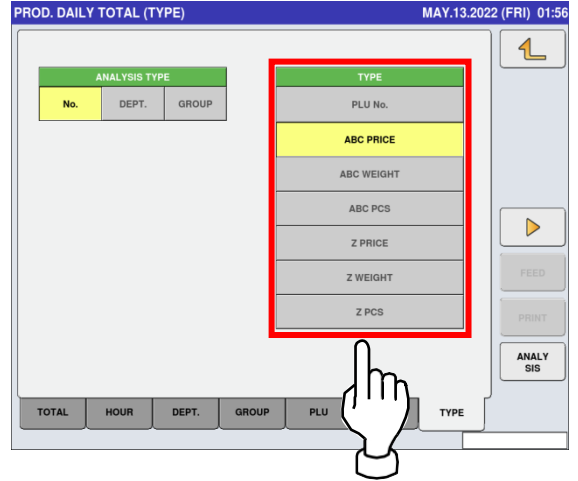

No.	The total analysis is performed for all products.
DEPT.	The total analysis is performed for all departments.
GROUP	The total analysis is performed for all groups.
PLU No.	The total analysis is performed in ascending PLU number order.
ABC PRICE	The total analysis is performed in descending price order.
ABC WEIGHT	The total analysis is performed in descending weight order.
ABC PCS	The total analysis is performed in descending quantity order.
Z PRICE	The total analysis is performed in ascending price order.
Z WEIGHT	The total analysis is performed in ascending weight order.
Z PCS	The total analysis is performed in ascending quantity order.

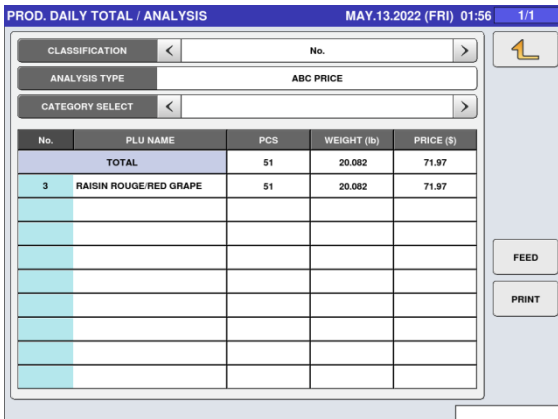

3.3 WEEKLY TOTALS

1. Press the “PROD. WEEKLY” icon.

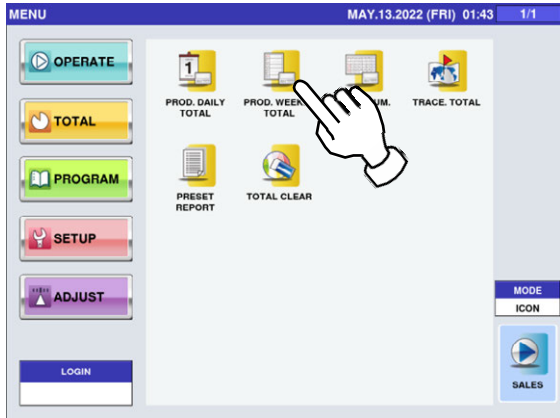

➔ The Weekly Total (Week) screen is displayed.

PROD. WEEKLY TOTAL (WEEK) MAY.13.2022 (FRI) 02:30 1/1

No.	WEEK DAILY	PCS	WEIGHT (lb)	PRICE (\$)
TOTAL				
0	SUN	0	0.000	0.00
1	MON	0	0.000	0.00
2	TUE	0	0.000	0.00
3	WED	0	0.000	0.00
4	THU	49	19.282	69.09
5	FRI	2	0.800	2.88
6	SAT	0	0.000	0.00

WEEK: SUN MON TUE WED THU FRI SAT

3. To display the “Production Weekly Total” total for the day-of-the week, press a desired day-of-the week tab.

To turn pages, press the [▼] or [▲].

PROD. WEEKLY TOTAL (SUN) MAY.13.2022 (FRI) 02:31 1/3

No.	WEEK DAILY	PCS	WEIGHT (lb)	PRICE (\$)
TOTAL				
0	00:00 - 00:59	0	0.000	0.00
1	01:00 - 01:59	0	0.000	0.00
2	02:00 - 02:59	0	0.000	0.00
3	03:00 - 03:59	0	0.000	0.00
4	04:00 - 04:59	0	0.000	0.00
5	05:00 - 05:59	0	0.000	0.00
6	6:00 - 6:59	0	0.000	0.00
7	7:00 - 7:59	0	0.000	0.00
8	8:00 - 8:59	0	0.000	0.00
9	9:00 - 9:59	0	0.000	0.00

WEEK: SUN MON TUE WED THU FRI SAT



PROD. WEEKLY TOTAL (SUN) MAY.13.2022 (FRI) 02:31 3/3

No.	WEEK DAILY	PCS	WEIGHT (lb)	PRICE (\$)
TOTAL				
20	20:00 - 20:59	0	0.000	0.00
21	21:00 - 21:59	0	0.000	0.00
22	22:00 - 22:59	0	0.000	0.00
23	23:00 - 23:59	0	0.000	0.00

WEEK: SUN MON TUE WED THU FRI SAT

3.4 CUMULATIVE TOTALS

1. Press the “PROD. CUM. TOTAL” icon.

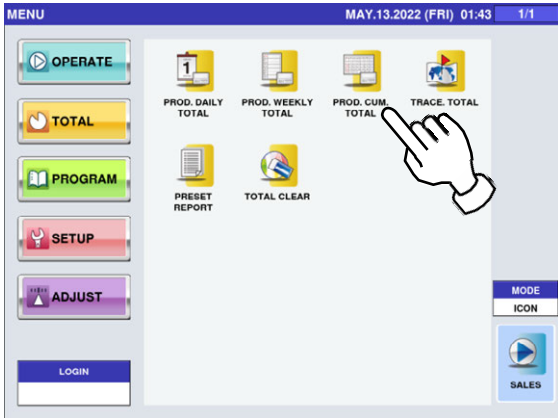

➔ The “Cumulative Total (Total) screen is displayed.

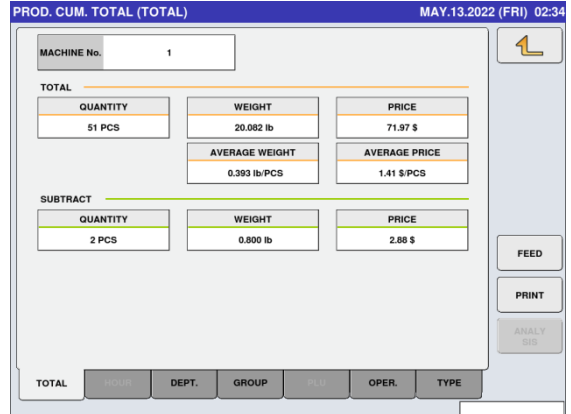

3. To display total for departments, press the “DEPT.” tab.

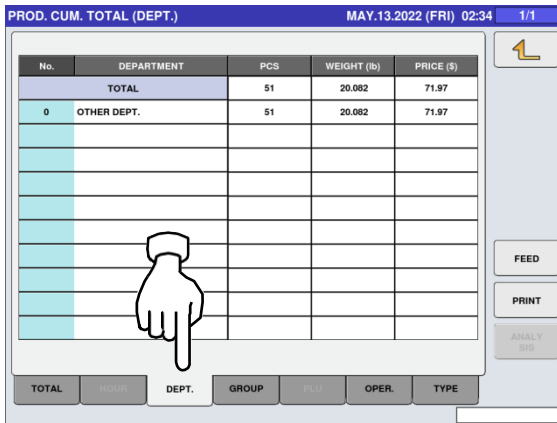

4. To display total for groups, press the “GROUP” tab.

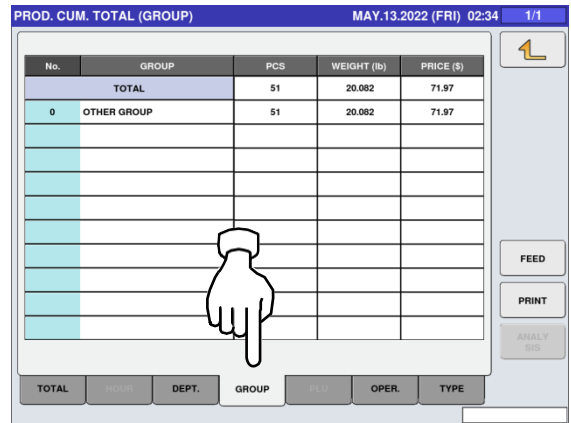

5. To display total for operators, press the “OPER.” tab.

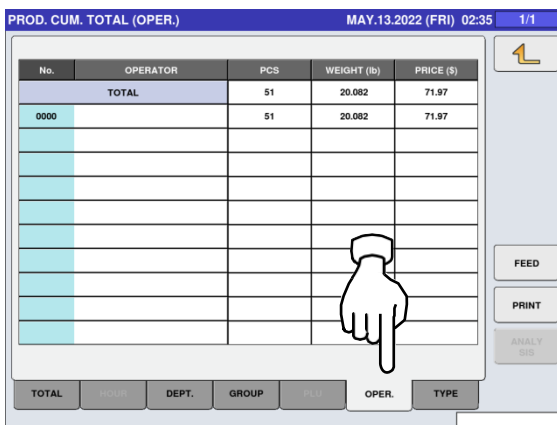

6. To display analysis totals, press the “TYPE” tab.

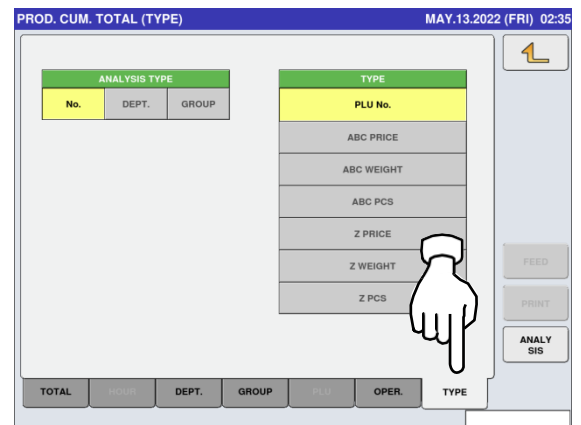

No.	The total analysis is performed for all products.
DEPT.	The total analysis is performed for all departments.
GROUP	The total analysis is performed for all groups.
PLU No.	The total analysis is performed in ascending PLU number order.
ABC PRICE	The total analysis is performed in descending price order.
ABC WEIGHT	The total analysis is performed in descending weight order.
ABC PCS	The total analysis is performed in descending quantity order.

Z PRICE	The total analysis is performed in ascending price order.
Z WEIGHT	The total analysis is performed in ascending weight order.
Z PCS	The total analysis is performed in ascending quantity order.

7. Select the target reports and listing order by pressing desired buttons, and press the [ANALYSIS] button.

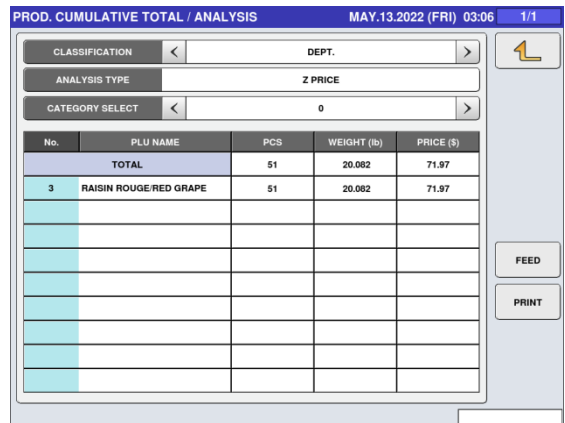
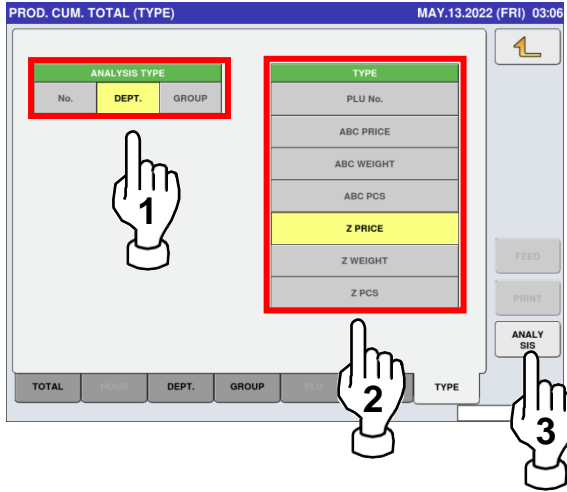

3.5 TRACEABILITY TOTALS

1. Press the "TRACE. TOTAL" icon.

➔ For more information, refer to the Service Manual for UNI-10.

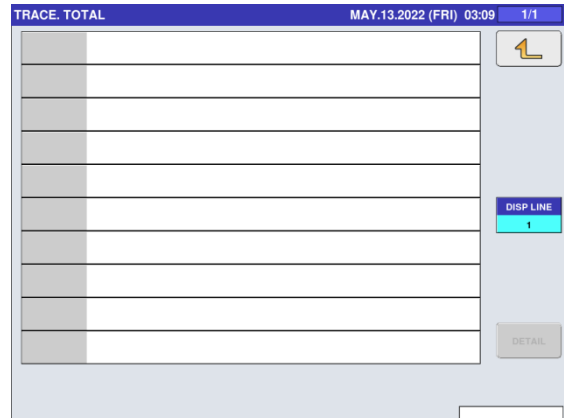
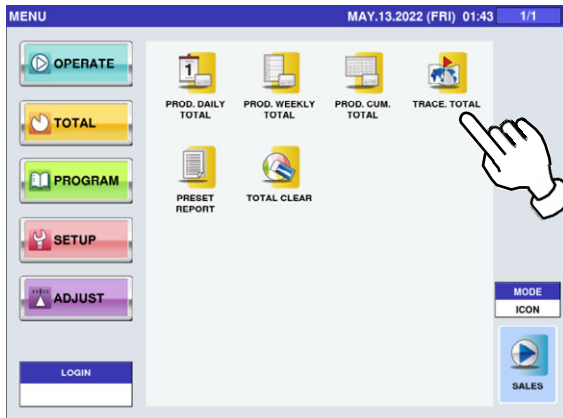

3.6 PRESET REPORTS

1. Press the “PRESET REPORT” icon.

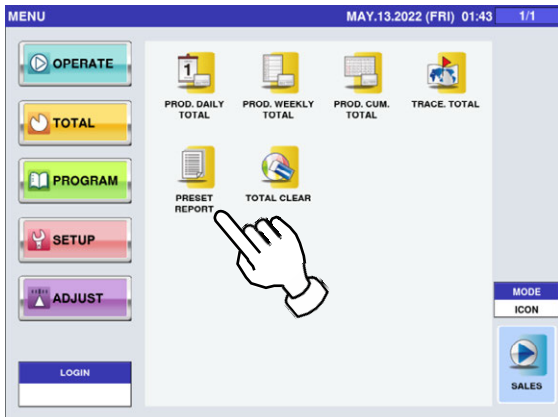

- The “Preset Report” screen is displayed.

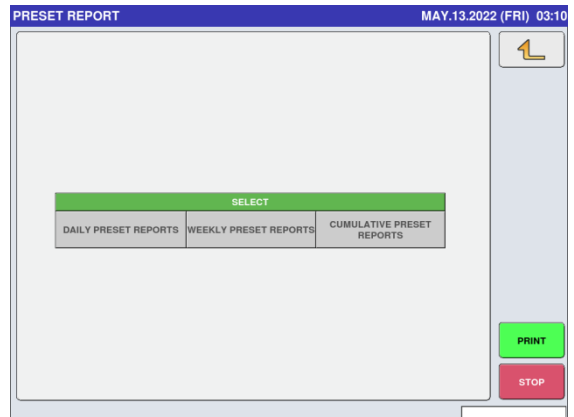

2. Select a desired report type by pressing the corresponding fields.
Press the [PRINT] button to issue the selected reports.

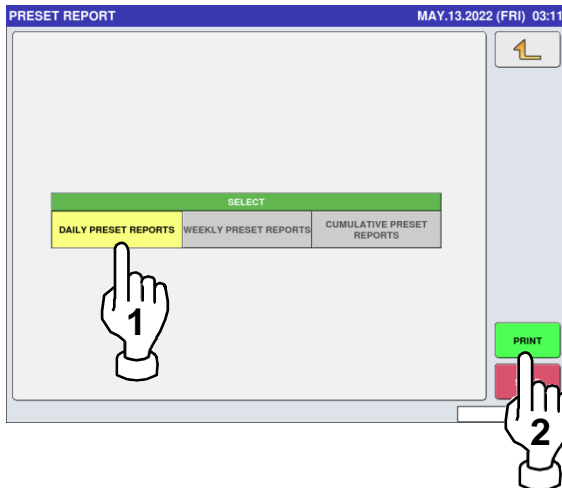

3.7 TOTAL CLEAR

1. Press the "TOTAL CLEAR" icon.

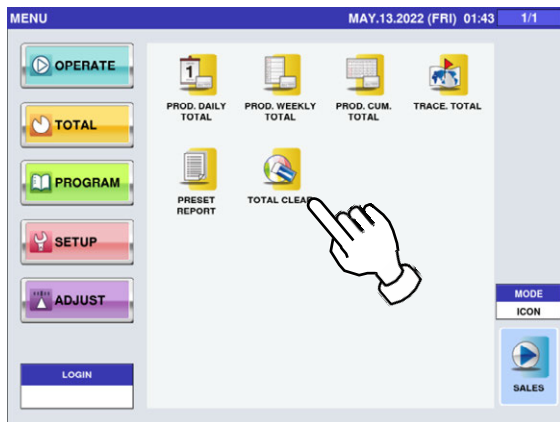

- ➔ The "Total Clear" screen is displayed.



2. Select desired reports to be cleared by pressing the corresponding fields. Then, press the [DELETE] button.

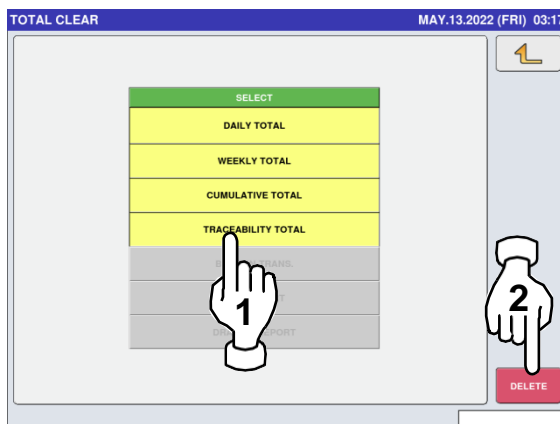

3. The confirmation screen is displayed. Press [EXEC] to continue, or [STOP] to go back.

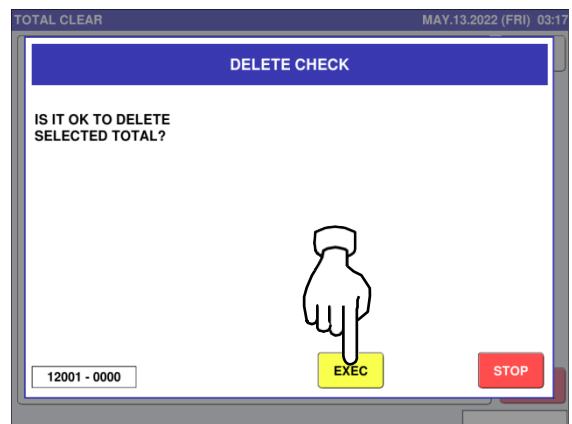

PROGRAM MODE

4.1 PROGRAM MODE ENTRY / EXIT

1. Ensure that the initial screen is displayed, and press the Return button on the screen.

Note: The contents of the initial screen may differ

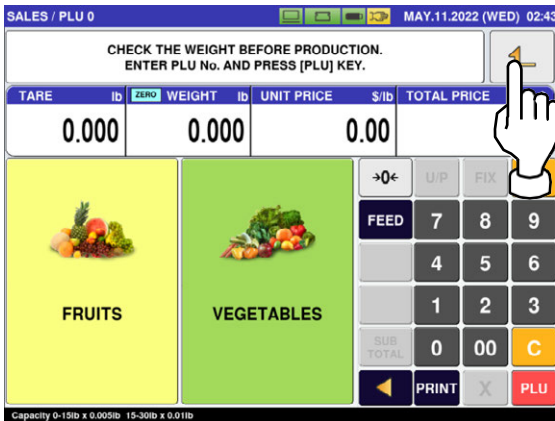

depending on the settings on your machine.

2.

The "Menu" screen is displayed. Then, press the [PROGRAM] button.

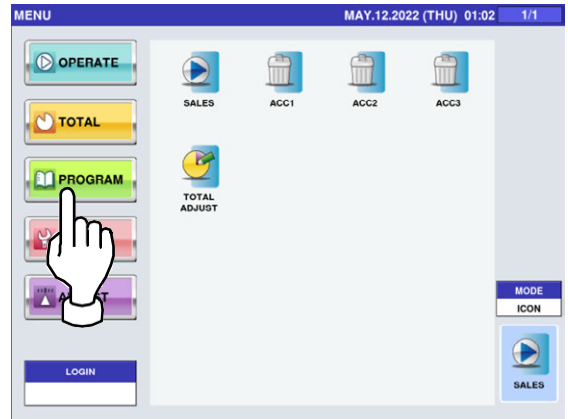

➔ The program menu selection screen is displayed.

To turn pages, press [▼] or [▲].



➔

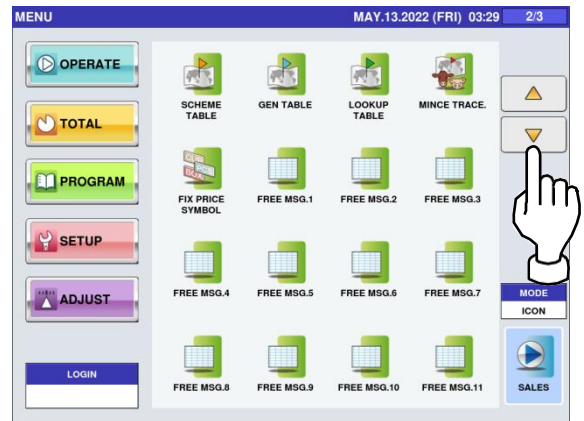

➔

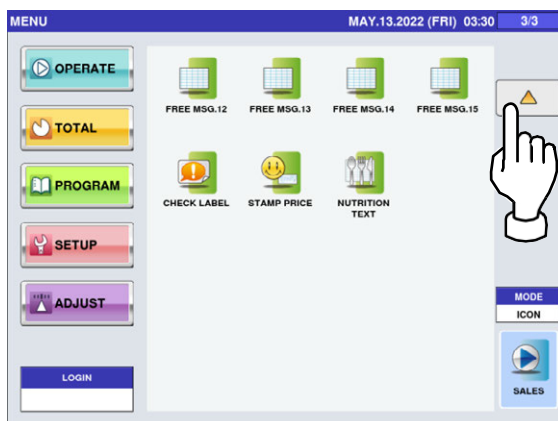

Note: To exit the Program Mode, press the [SALES] button.

4.2 PLU DATA

1. Press the “PLU” icon on the menu selection screen.



- ➔ The “PLU” screen is displayed. To turn pages, press [▼] or [▲].

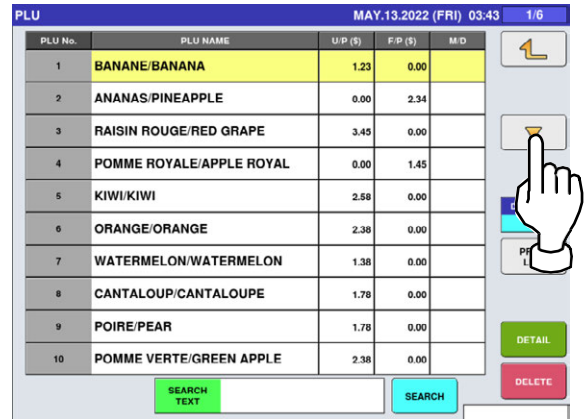

2. Select a desired PLU by pressing the corresponding field, and press the [DETAIL] button.

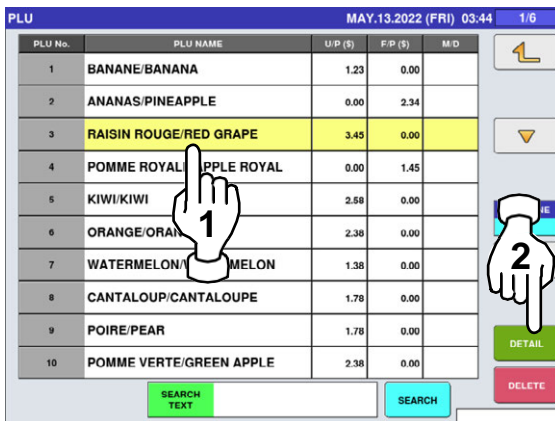

3. The “PLU Detail (Sales)” screen is displayed. To edit the PLU name, press the name field.

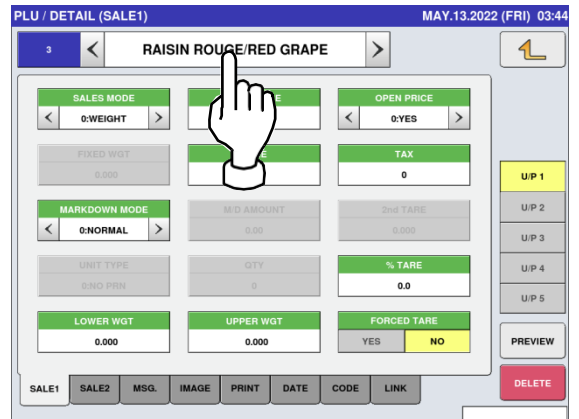

4. The “PLU Name Edit” screen is displayed. Edit text according to the procedure described in Appendix “Text Editing”.

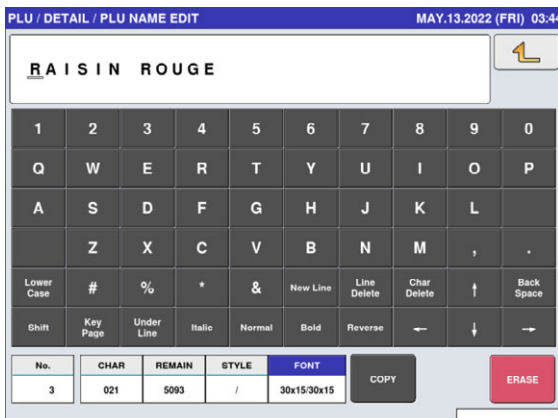

5. Press the “SALE 1” tab to display the “PLU Detail (Sale 1)” screen. The screen below shows that “Sales Mode” is set for selling weighing products.

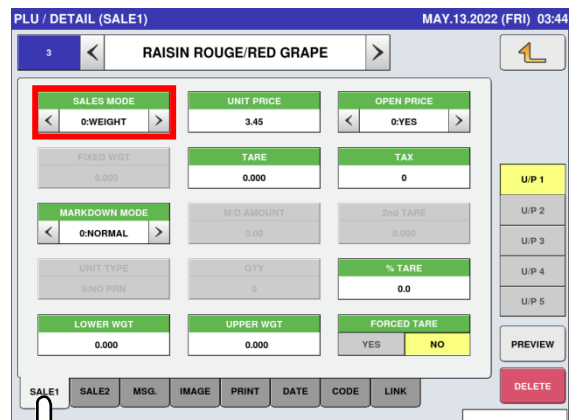



PLU / DETAIL (SALE1)
MAY.13.2022 (FRI) 03:45

3
RAISIN ROUGE/RED GRAPE
L

SALES MODE

1:FIX PRI

FIXED PRICE

3.45

OPEN PRICE

0:YES

FIXED WGT

0

TARE

0.000

TAX

0

MARKDOWN MODE

0:NORMAL

M/D AMOUNT

0.00

2nd TARE

0.000

UNIT TYPE

0:NO PRN

QTY

0

% TARE

0.0

LOWER WGT

0.000

UPPER WGT

0.000

FORCED TARE

YES
NO

SALE1
SALE2
MSG.
IMAGE
PRINT
DATE
CODE
LINK

U/P 1
U/P 2
U/P 3
U/P 4
U/P 5
PREVIEW
DELETE

SALES MODE	<p>Press [] or [] to select a desired sales mode.</p> <p>0: Weight (for selling weighing products)</p> <p>1: Fix price (for selling fixed price products)</p> <p>2: Weight fix price (for selling weighing fixed price products)</p> <p>3: Fix unit price (for selling fixed unit price products)</p> <p>4: Weight (100 g) (when the setting of the unit price per 100 g is needed in accordance of the laws of a country)</p> <p>5: Fix unit price (minus) (when the setting of the minus sale is needed in accordance of the laws of a country)</p>
UNIT PRICE / FIXED PRICE	Enter the unit price or fixed price and press this field.
OPEN PRICE	<p>Press [] or [] to select whether or not to allow an open price system.</p> <p>0: Yes</p> <p>1: No</p>
FIXED WEIGHT	Enter the fixed weight and press this field.
TARE	Enter the tare weight and press this field.
TAX	Enter a numerical value and press this field.
MARKDOWN MODE	<p>Press [] or [] to select a desired markdown mode.</p> <p>0: Normal price</p> <p>1: Special price</p> <p>2: Amount discount for total price</p> <p>3: Percent discount for total price</p> <p>4: Special unit price</p> <p>5: Amount discount for unit price</p> <p>6: Percent discount for unit price</p>
M/D AMOUNT	Enter the markdown amount or percentage and press this field.
2nd TARE	Enter the tare weight, and press this field.

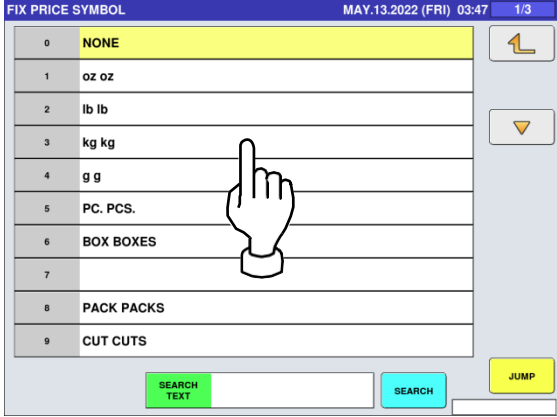
<p>UNIT TYPE</p>	<p>Press the "UNIT TYPE" field to display the "Fix Price Symbol" screen. Then, press a desired field for selection.</p> 
<p>QTY</p>	<p>Enter the packed quantity and press this field.</p>
<p>TARE</p>	<p>Enter the tare percentage and press this field.</p>
<p>LOWER WEIGHT</p>	<p>Enter the lower weight limit and press this field.</p>
<p>UPPER WEIGHT</p>	<p>Enter the upper weight limit and press this field.</p>
<p>FORCED TARE</p>	<p>Press [Yes] or [No] button to select whether or not to use the forced tare function.</p>

6. Press the "SALE 2" tab to select the second sale related screen.

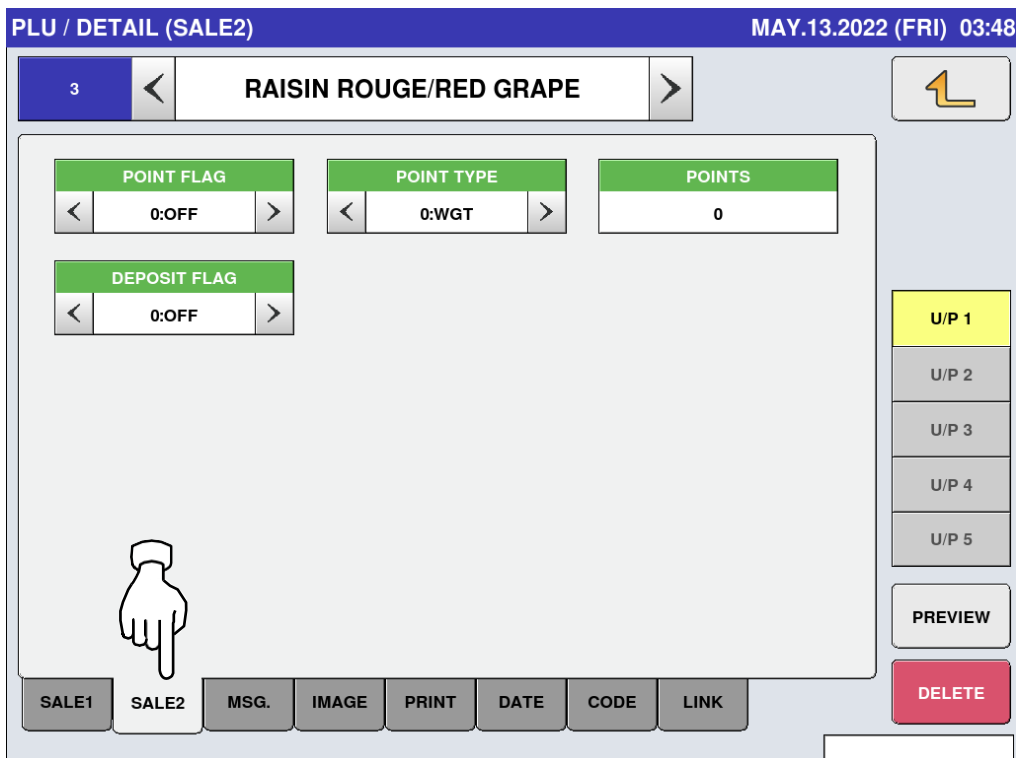

ITEM	DESCRIPTIONS
POINT FLAG	Press [] or [] to select whether or not to use the point flag.
	0: OFF 1: ON
POINT TYPE	Press [] or [] to select a desired point type.
	0: Weight 1: Fixed weight
POINTS	Enter a desired number and press this field.

7. Press the “MSG.” tab to select the message related screen.

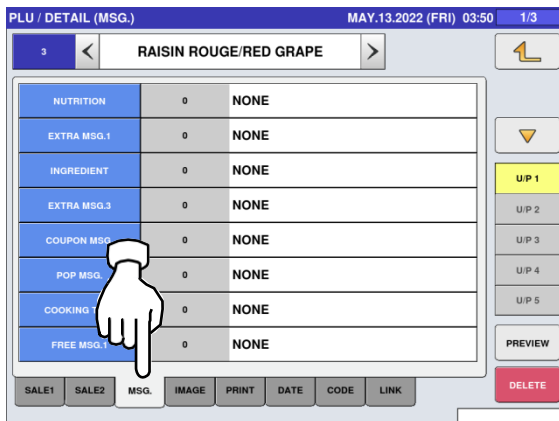

8. Press a desired field for selection.

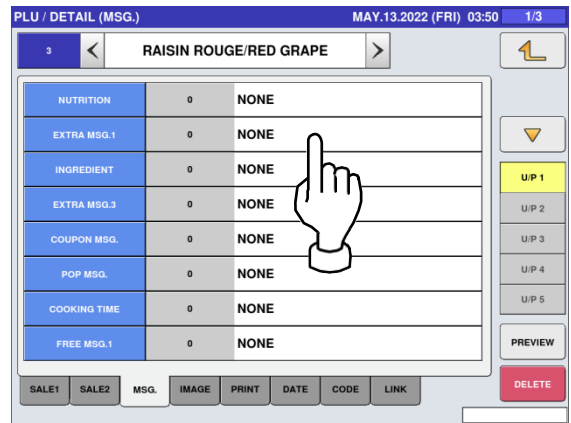

9. The “Extra Message” screen is displayed. Press a desired field for selection.

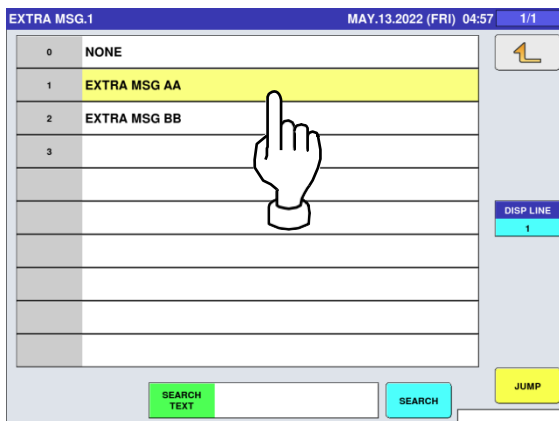

The selected message has been registered.



10. Press the “IMAGE” tab to display the “PLU/ Detail (Image)” screen.

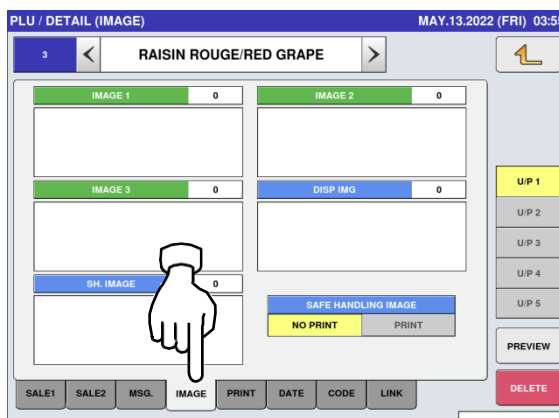

11. Press a desired field for selection.

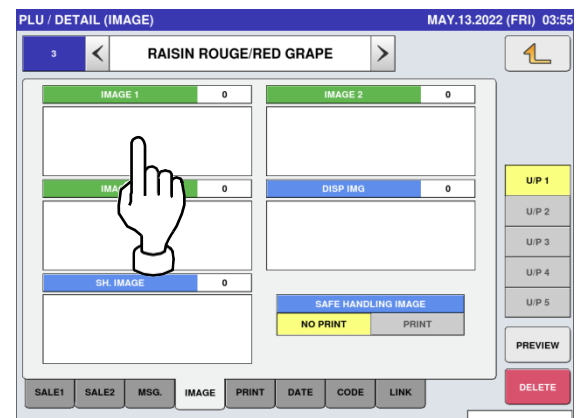

12. The "Image" screen is displayed.
Press a desired image for selection.

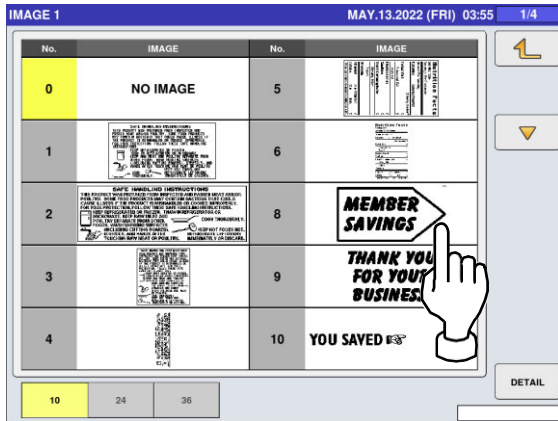

13. The selected image has been registered.
Press [NO PRINT] or [PRINT] in the "Safe Handling Image" field to select whether or not to print the image.

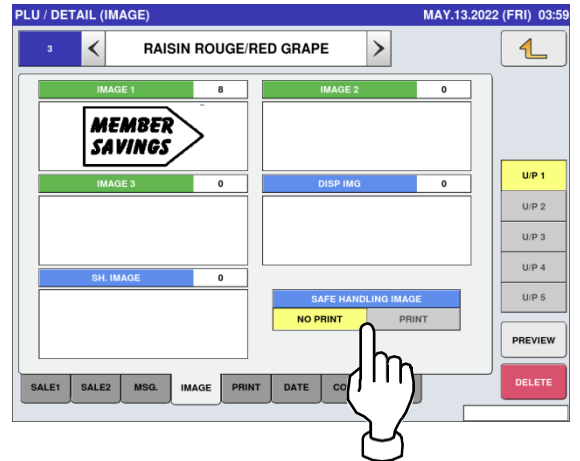

14. Press a desired display image field.

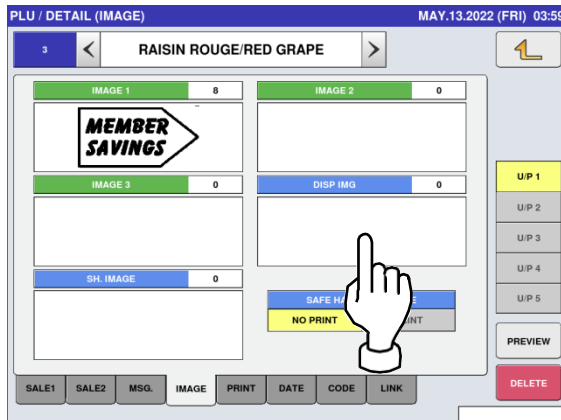

15. The Display Image screen is displayed.
Press a desired image for selection.
Note: To use images stored in the USB memory, press [STORAGE] key. The movie file with the format of MPEG-4, 800 x 600 (SVGA), 10 Mbps, 25 FPS can also be used.
Then, press the [SET] button.



The selected image has been registered.

16. Press [NO PRINT] or [PRINT] in the “Safe Handling Image” field to select whether or not to print the image.

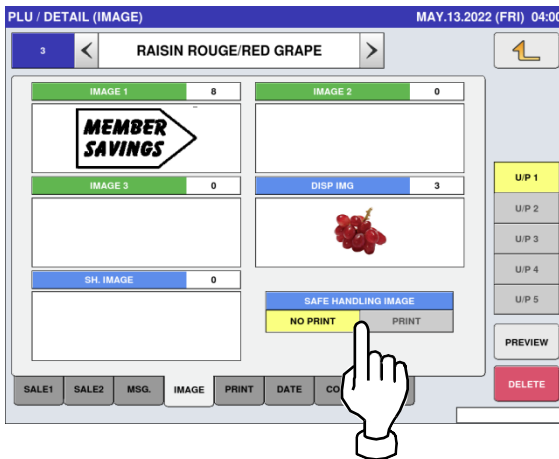

17. Press the “PRINT” tab to display the PLU / Detail (Print) screen.

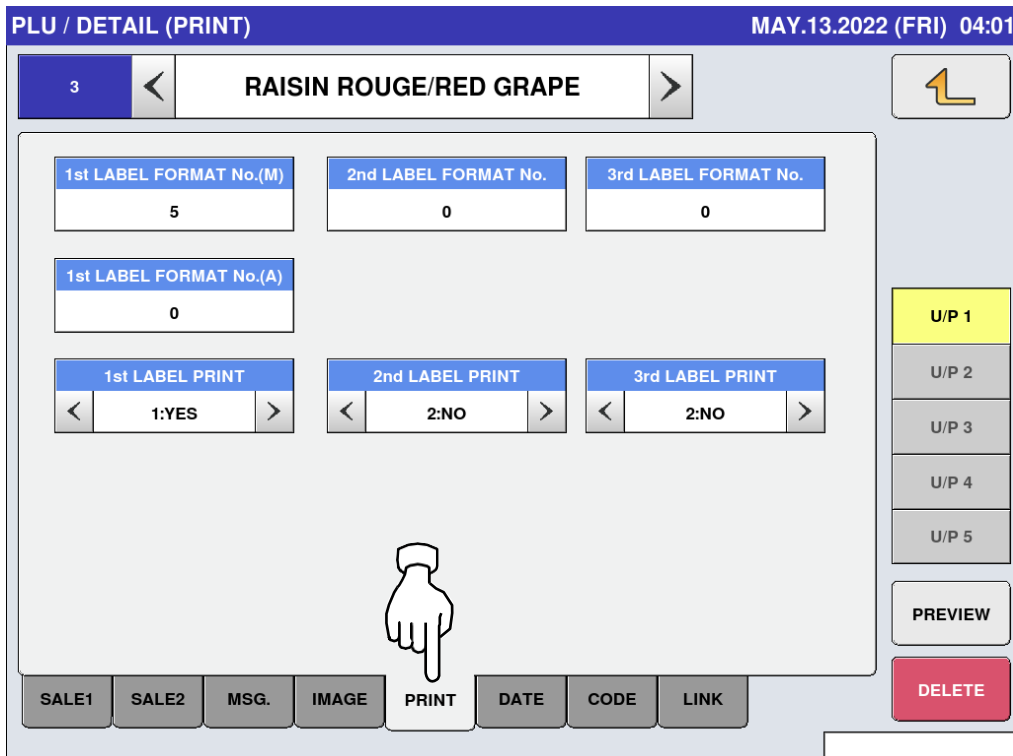

ITEM	DESCRIPTIONS
1st LABEL FORMAT No. (M)	Enter a desired format number and press this field.
2nd LABEL FORMAT No.	Enter a desired format number and press this field.
1st LABEL FORMAT No. (A)	Enter a desired format number and press this field.
1st LABEL PRINT	Press [] or [] to select whether or not to print the first label. 1: Yes 2: No
2nd LABEL PRINT	Press [] or [] to select whether or not to print the second label. 1: Yes 2: No

18. Press the “DATE” tab to display the PLU / Detail (Date) screen.

PLU / DETAIL (DATE) MAY.13.2022 (FRI) 04:02

3 < RAISIN ROUGE/RED GRAPE >

PACK DATE PRINT <input checked="" type="checkbox"/> YES <input type="checkbox"/> NO	PACK TIME PRINT <input type="checkbox"/> < 2:CLOCK >	PACK TIME DATA ---
SB DATE PRINT <input checked="" type="checkbox"/> YES <input type="checkbox"/> NO	SB TIME PRINT <input type="checkbox"/> < 0:NO PRINT >	SB TIME DATA 0 MIN.(S) AFTER
SHELF LIFE(days) 3 days	USE BY DATE PRINT <input type="checkbox"/> YES <input checked="" type="checkbox"/> NO	UB DATE DATA

U/P 1

U/P 2

U/P 3

U/P 4

U/P 5

PREVIEW

DELETE



SALE1 SALE2 MSG. IMAGE PRINT DATE CODE LINK

ITEM	DESCRIPTIONS
PACK DATE PRINT	Press [YES] or [NO] in this field to select whether or not to print the packed date.
PACK TIME PRINT	Press [] or [] to select a desired pack time printing method. 0: No print 1: Designated time 2: System clock time
PACK TIME DATA	This field is available only when “1: Designated time” is selected in “PACK TIME PRINT”. Enter the time and press this field.
SB DATE PRINT	Press [YES] or [NO] in this field to select whether or not to print the sell-by date.
SB TIME PRINT	Press [] or [] to select a desired selby time printing method. 0: No print 1: Designated time 2: Relative time
SB TIME DATA	This field is available only when “Yes” is selected in “SB TIME PRINT”. Enter the number of hours and press this field.
SHELF LIFE (days)	This field is available only when “Yes” is selected in “SB DATE PRINT”. Enter the number of days and press this field.
USE BY DATE PRINT	Press [YES] or [NO] in this field to select whether or not to print the use-by date.
UB DATE DATA	This field is available only when “Yes” is selected in “USE BY DATE PRINT”. Enter the number of hours and press this field.

19. Press the “CODE” tab to select the PLU / Detail (Code) screen.

ITEM	DESCRIPTIONS
ITEM CODE	Enter an item code and press this field.
REG CODE	Enter the register code and press this field.
POS FLAG	This field is available only when “1: PLU File” is selected in “POS REFERENCE”. Enter a POS flag number and press this field.
BARCODE	Enter a barcode number and press this field.
POS REFERENCE	Press [] or [] to select a desired reference method. 0: Refer 1: PLU file
BARCODE TYPE	This field is available only when “1: PLU File” is selected in “POS REFERENCE”. Press this field to display the Barcode Type screen, and press a desired PLU type for selection.

Code	Description	Code	Description
000	REFER	010	ITF
001	EAN/UPC 13	011	Not Available
002	EAN/UPC 8		
003	10 DIGITS 13		
004	5 DIGITS 8		
005	GS1		
006	GS1 ST		
007	GS1 STO		
008	GS1 LIM		
009	GS1 EXP		

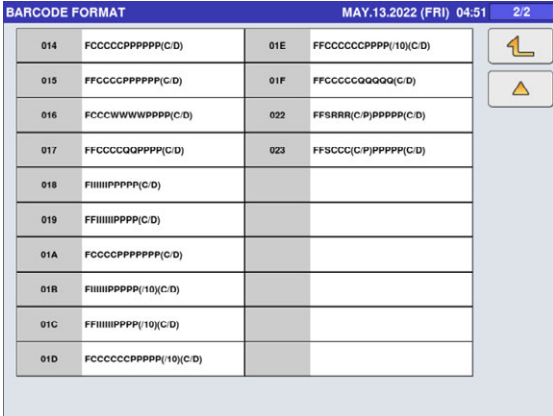
<p>POS FORMAT (WGT)</p>	<p>Press this field to display the Barcode Format screen, and press a desired barcode format for selection.</p>  
<p>TRACE ENABLE</p>	<p>Press [YES] or [NO] in this field to select whether or not to enable a traceability function.</p>
<p>DEPARTMENT No.</p>	<p>Press this field to display the Department screen. To set a department, press a desired field on the list, or press the "DEPARTMENT No." field after numerical entry.</p>
<p>GROUP No.</p>	<p>Press this field to display the Group screen. To set a group, press a desired field on the list, or press the "GROUP No." field after numerical entry.</p>

4.3 CAMPAIGN DATA

1. Press the "CAMPAIGN" icon on the menu selection screen.

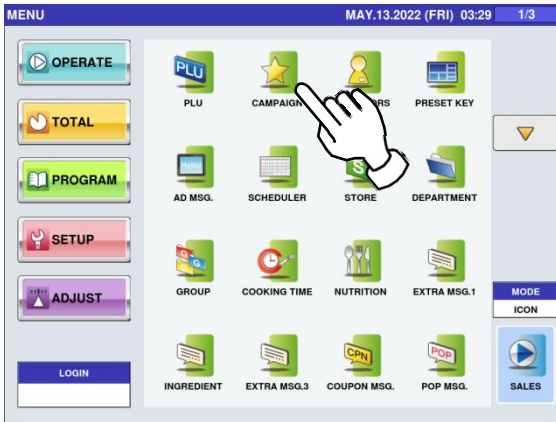

- 2-1 The "Campaign" screen is displayed. To create the first data, press the [NEW] button.



- 2-2 To call up desired data, press the Input field at the bottom right of the screen to display the keypad. Then, enter a numerical value and press the [PLU] key on the keypad.

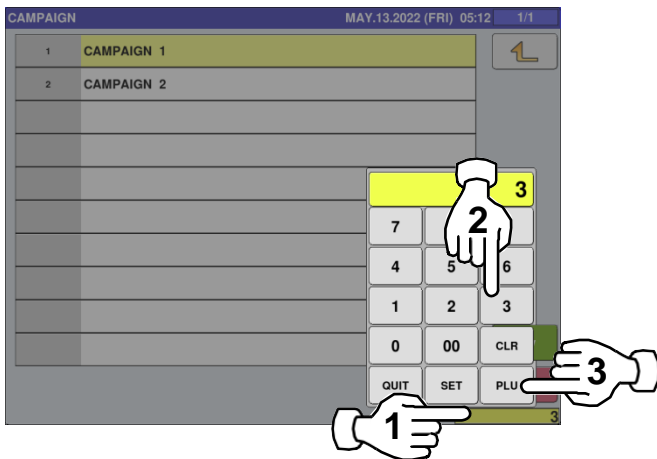

- 2-3 To change existing data, press a desired field for selection and then the [DETAIL] button.

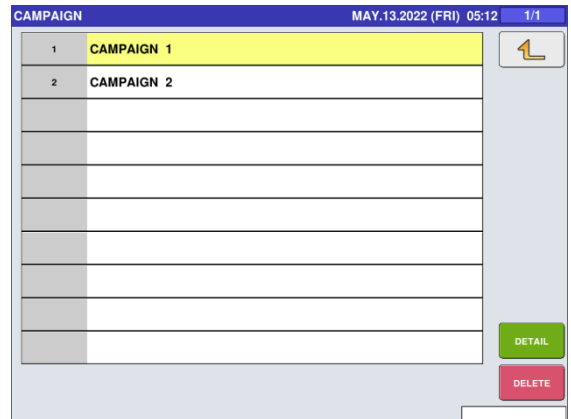

In this case, go to Step 4.

3. If a non-registered item has been called, the confirmation screen is displayed. Press [EXEC] to continue, or [STOP] to go back.

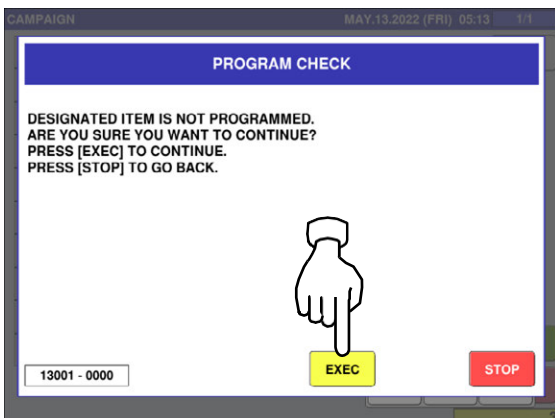

4. The "Campaign / Detail (Data)" screen is displayed. Press the [CALL] button to call up the PLU screen.

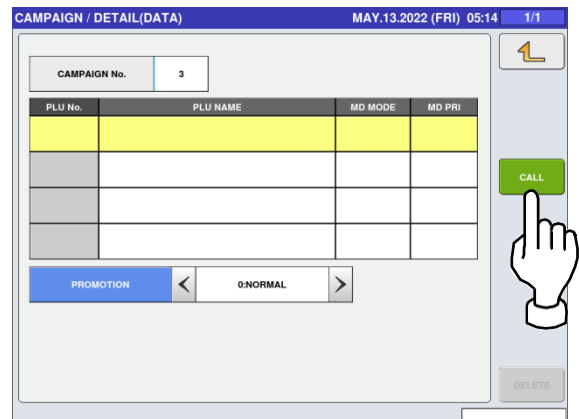

5. The PLU screen is displayed.
Press a desired item field for selection.

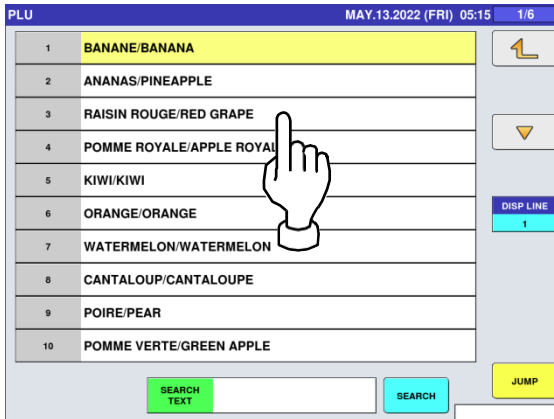

6. The designated "Campaign / Detail (Data)" screen is displayed.
Press the "MD MODE" field.

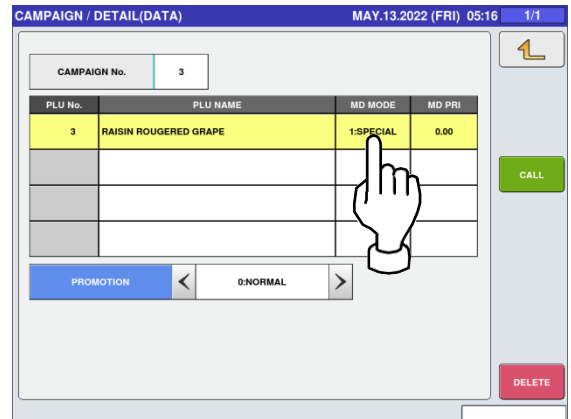

7. The Campaign / Mode List screen is displayed.
Press a desired field for selection.

EXAMPLE Percent discount "-%"

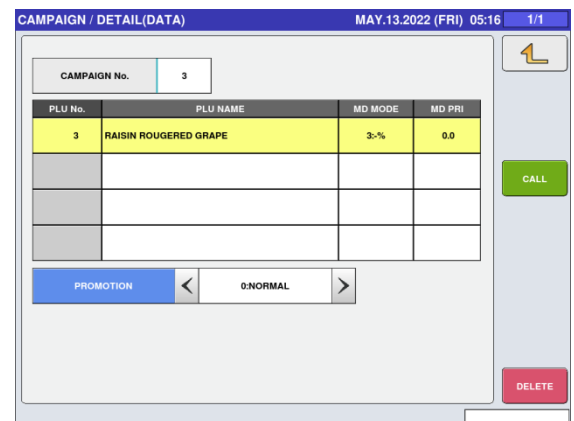
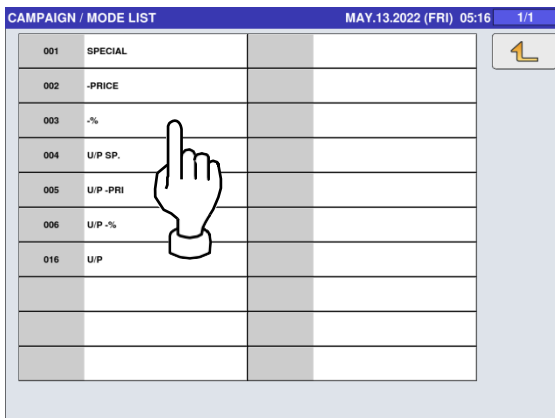

8. Press the "MD PRI" field to display the keypad on the screen.
Enter a numerical value and press the [SET] key on the key pad.

EXAMPLE 10%

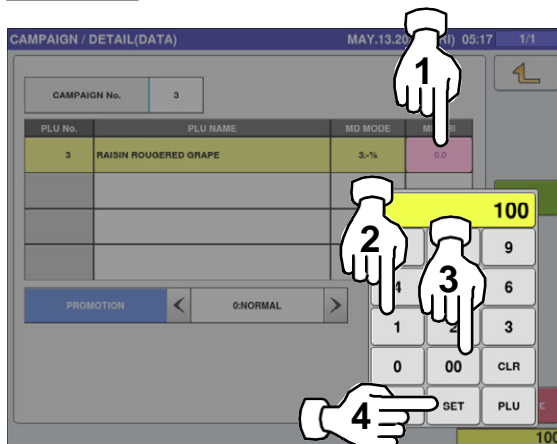

4.4 OPERATOR DATA

1. Press the “OPERATORS” icon on the menu selection screen.



2. The “Operator” screen is displayed. To call up desired data, press the Input field at the bottom right of the screen to display the keypad. Then, enter a numerical value and press the [PLU] key on the keypad.

EXAMPLE Operator No.13

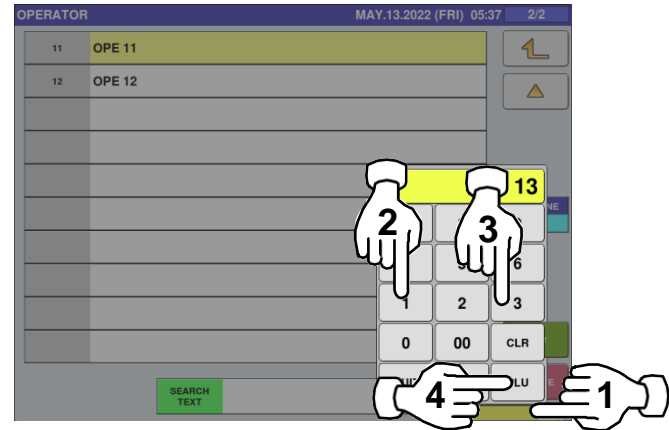

3. To change existing data, press a desired field for selection and then the [DETAIL] button.

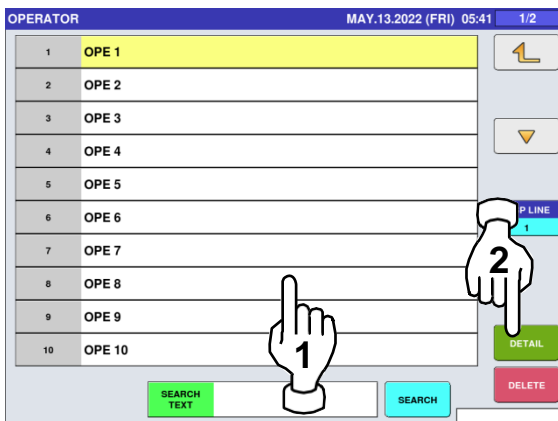

4. If a non-registered item has been called, the confirmation screen is displayed. Press [EXEC] to continue, or [STOP] to go back.

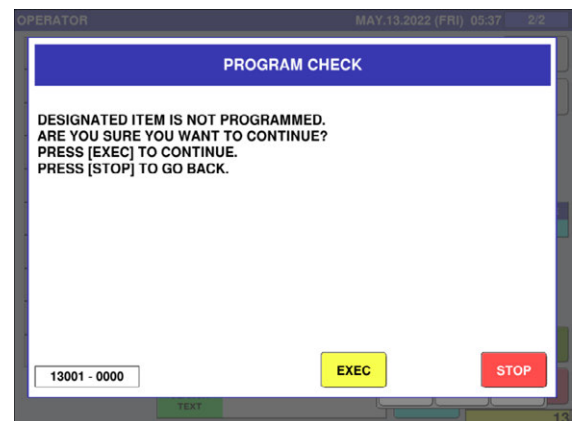

5. The “Operator / Detail” screen is displayed. To register the operator name, press the name field.

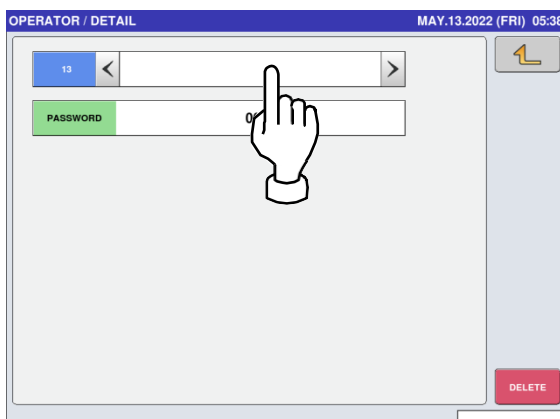

6. The Operator / Detail Edit screen is displayed for the designated operator number. Edit text according to the procedure described in Appendix “Text Editing”.

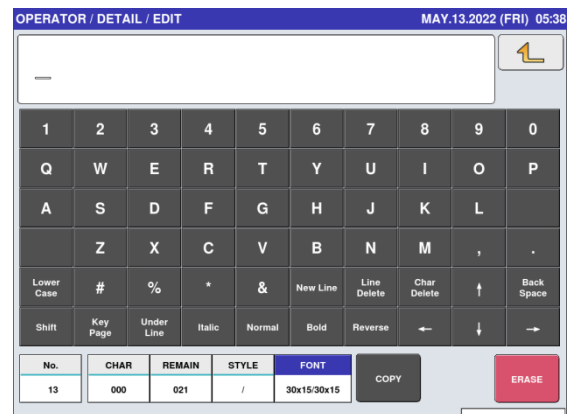

7. To finish the editing, press the Return button.



8. To set a password, press the Input field at the bottom right of the screen to display the keypad.
Enter the 4-digit numerical value and press the [SET] key on the keypad, and then press the "PASSWORD" field.

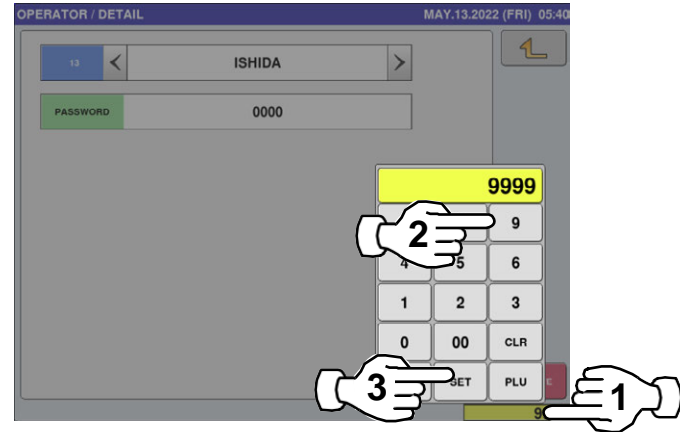

9. Press the Return button to finish the editing.

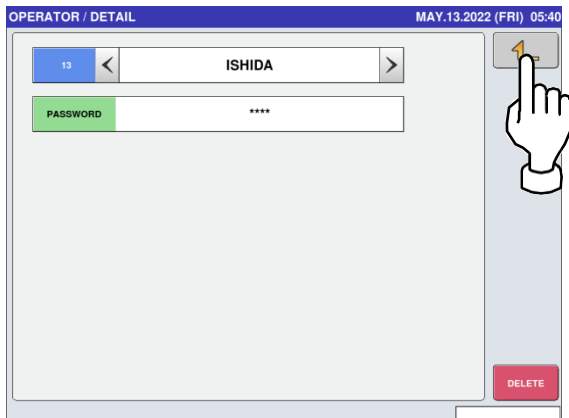

10. The confirmation screen is displayed. To confirm changes, press [SAVE]. To undo changes, press [CANCEL].

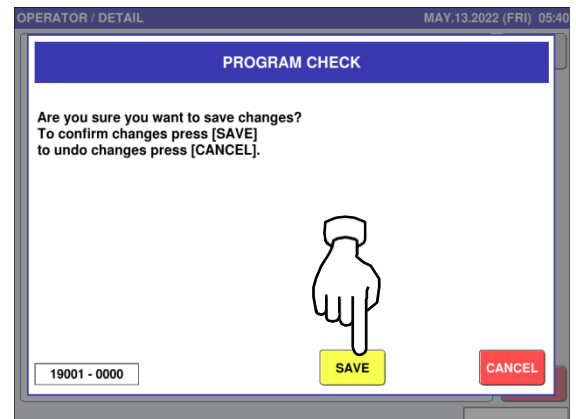

11. The edited data has been registered.

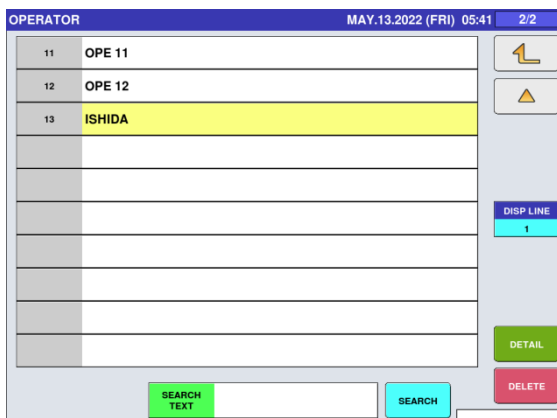

4.5 PRESET KEY REGISTRATION

4.5.1 SETTING PRESET GROUPS AND PAGES

1. Press the "PRESET KEY" icon on the menu selection screen.

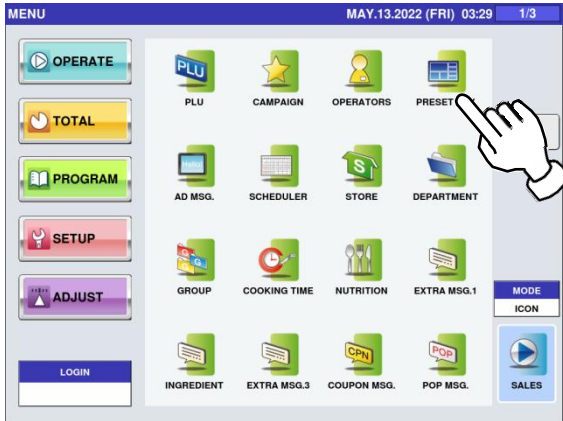

2. The Preset Key screen is displayed. Press a desired field for selection, and press the [DETAIL] button.

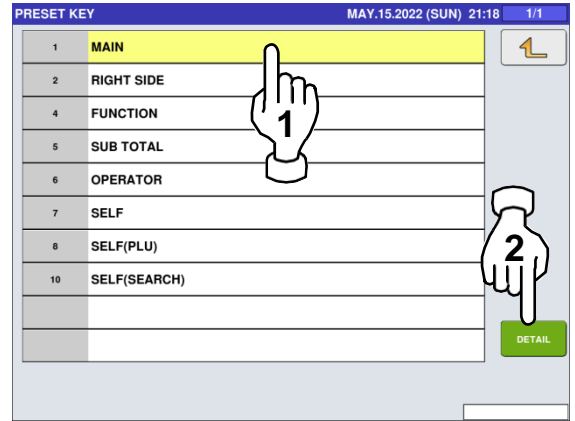

3. The edit screen is displayed. Press [<] or [>] to select the group or page number.

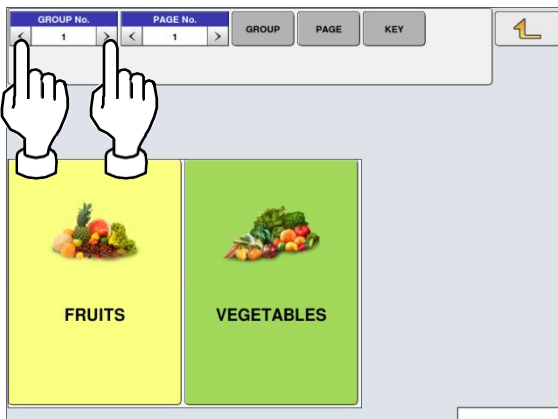

4. To create or delete the group or the page, press the [GROUP] or [PAGE] button, and then press a desired function button as shown below.

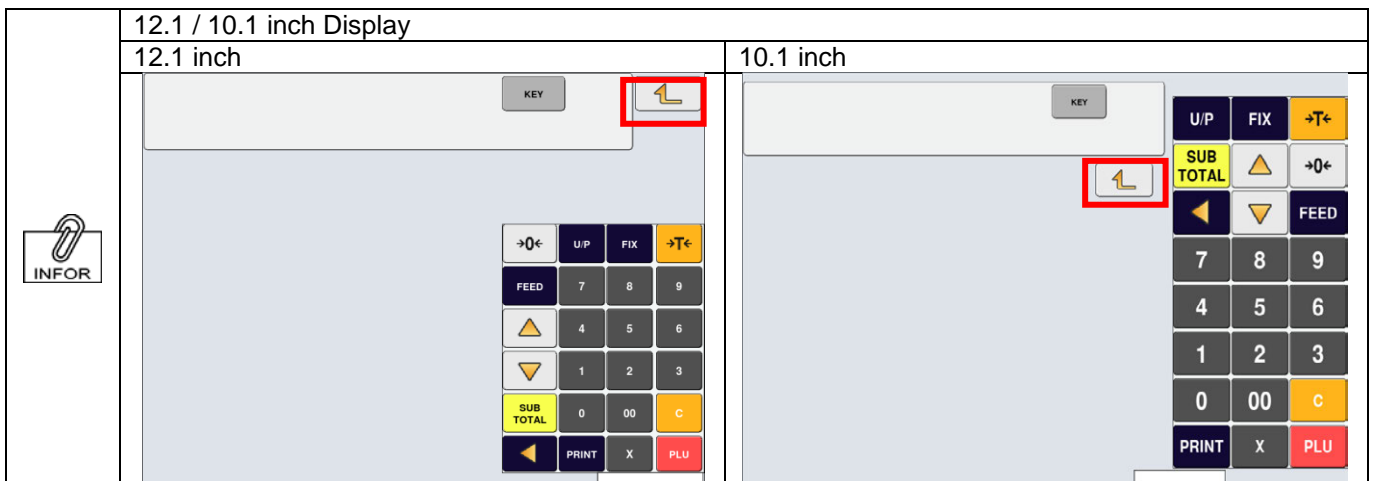
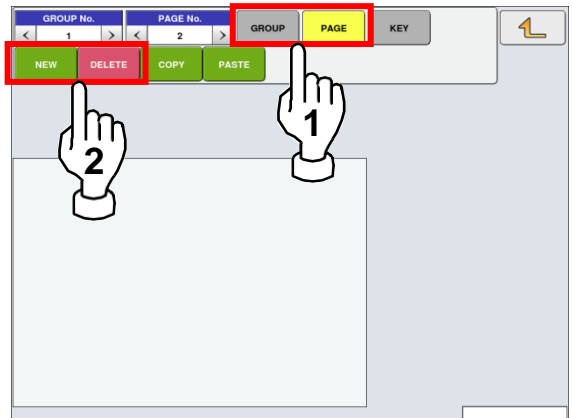

4.5.2 SETTING PRESET KEYS

1. Press the "PRESET KEY" icon on the menu selection screen.

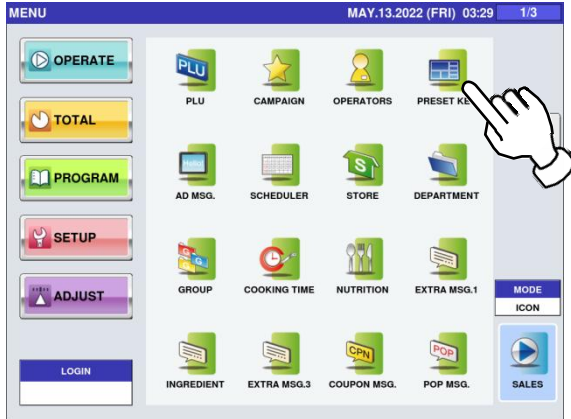

2. The "Preset Key" screen is displayed. Press a desired field for selection, and press the [DETAIL] button.

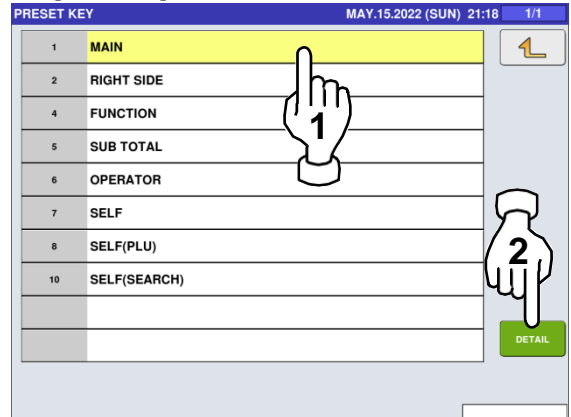

3. Select the group and the page where you want to add the preset key, and then press the [KEY] button and then [NEW] button.

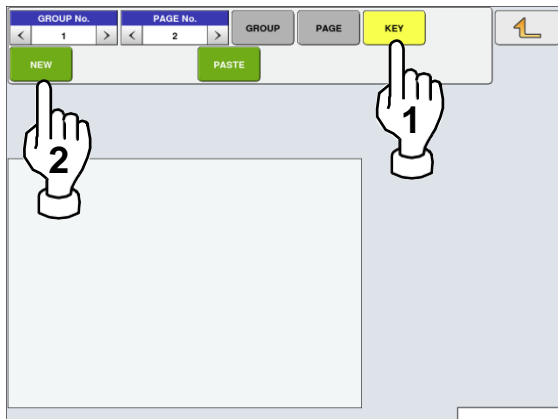

- Available preset keys are listed on the screen. To turn pages, press [▼] or [▲].

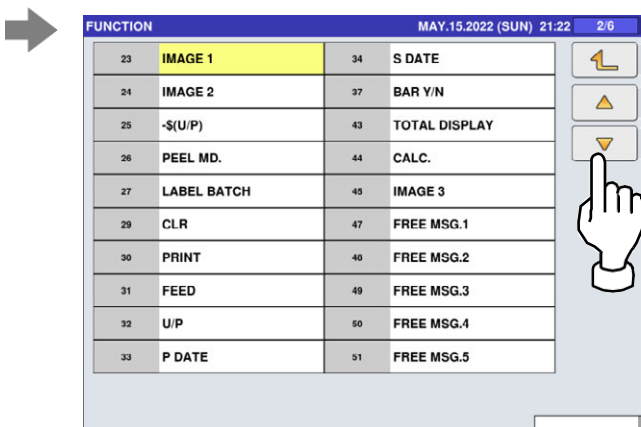
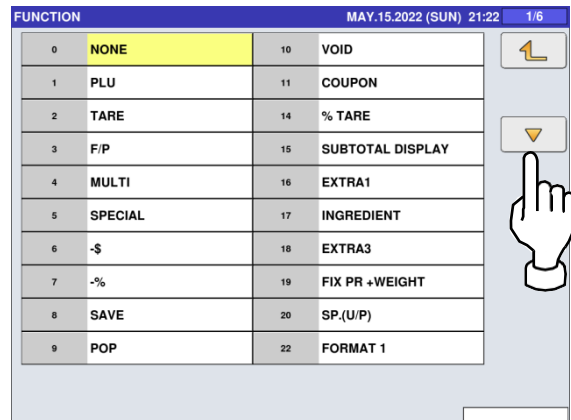

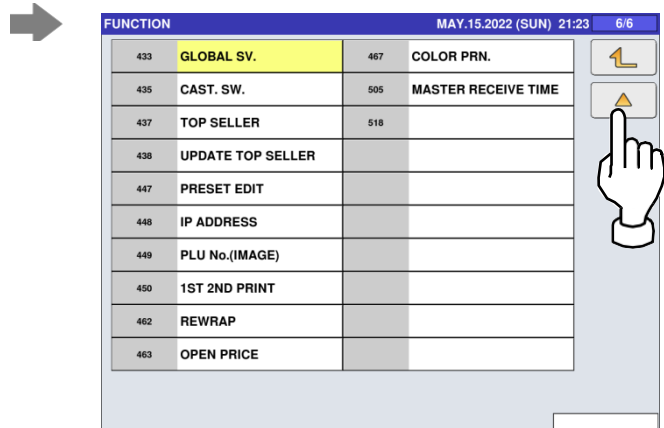
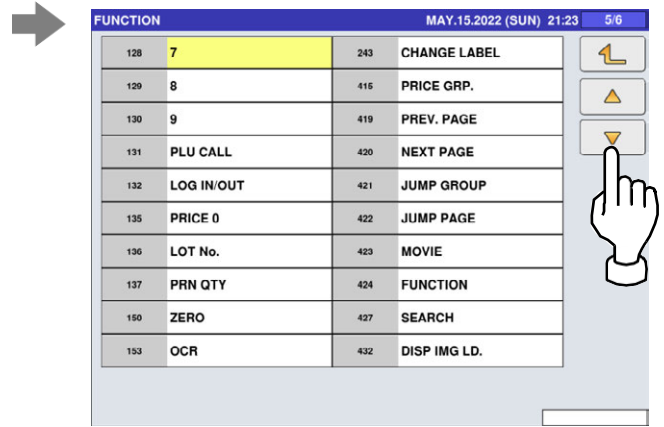
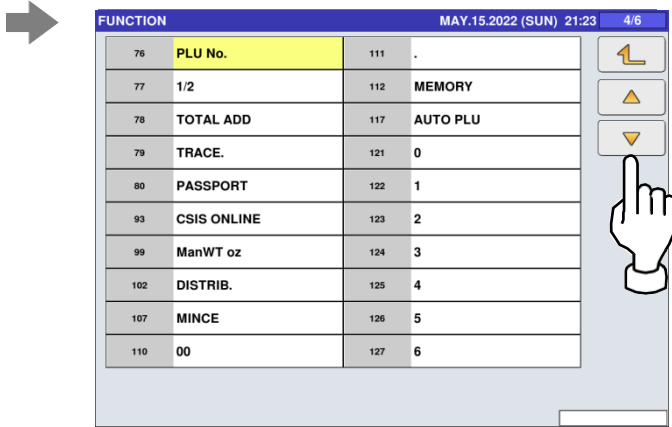

4. Press a desired function for selection.
EXAMPLE Selecting the PLU function

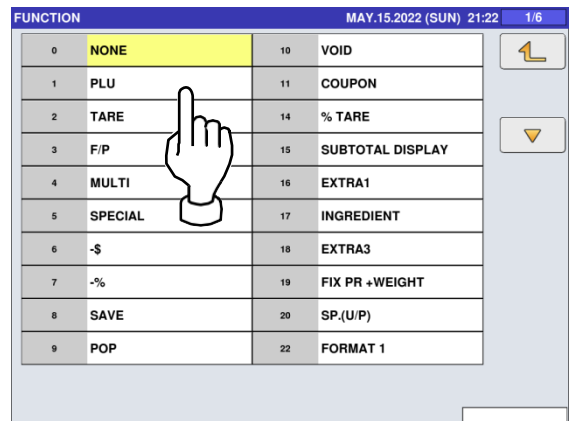

5. The PLU screen is displayed.
 Press a desired field for selection.

EXAMPLE PLU No.3



6. The selected preset key has been assigned.

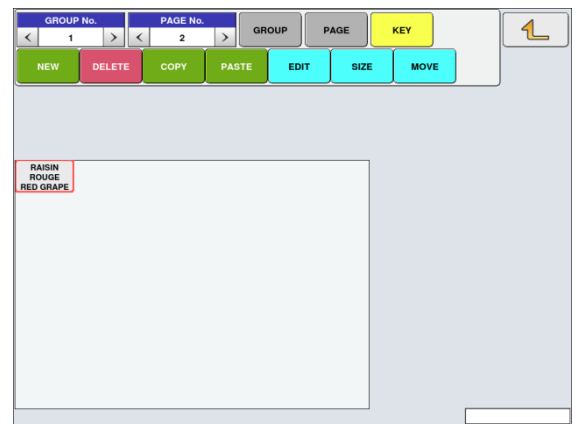

4.5.3 CHANGING PRESET KEY SIZES AND POSITIONS

1. Press the "PRESET KEY" icon on the menu selection screen.

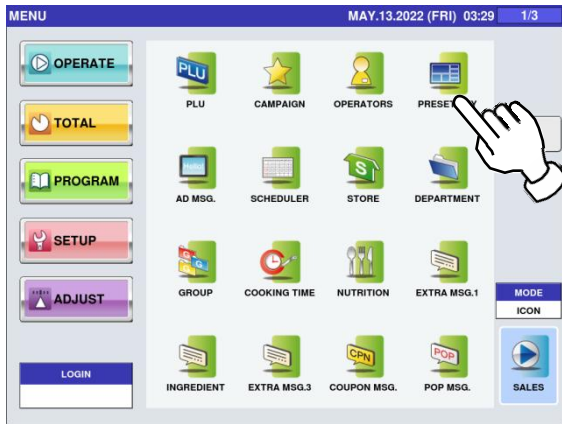

2. The "Preset Key" screen is displayed. Press a desired field for selection, and press the [DETAIL] button.

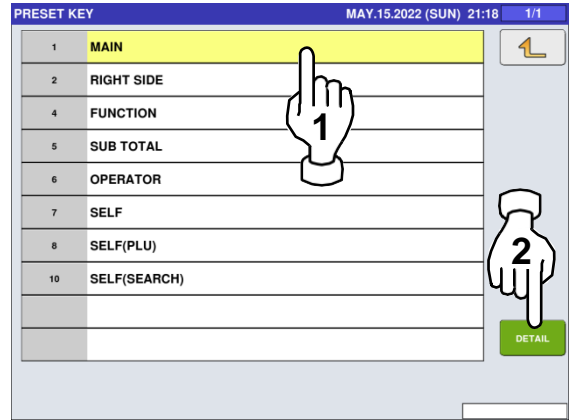

3. Select the group and the page that the preset key you want to edit is located, and then press [KEY] key, desired preset key, and [SIZE] or [MOVE] key.

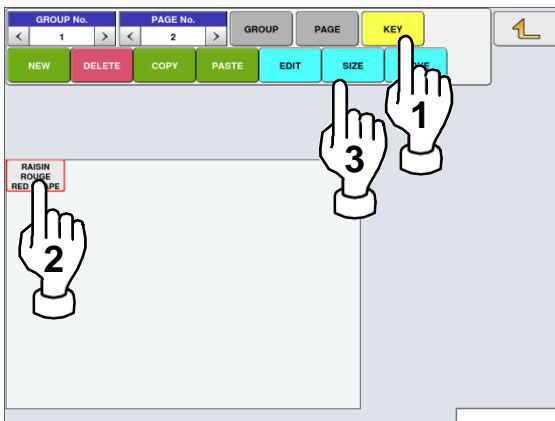

4. The size and position editing screen is displayed.

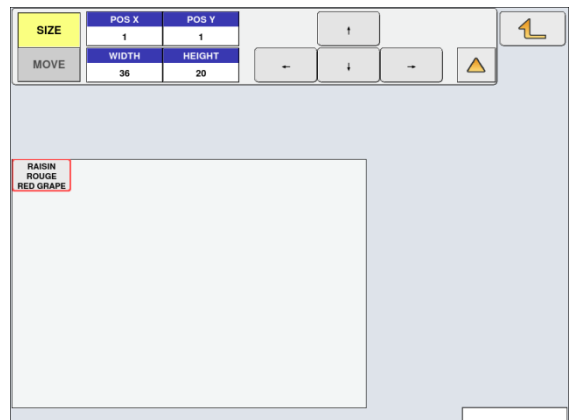

5. Press either the [SIZE] or [MOVE] button.

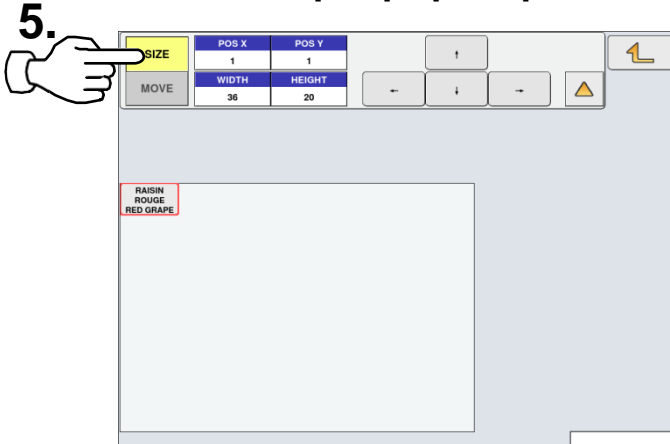

6. Set desired key size and position by using the input fields and arrow buttons, followed by pressing the [SET] key on the keypad.

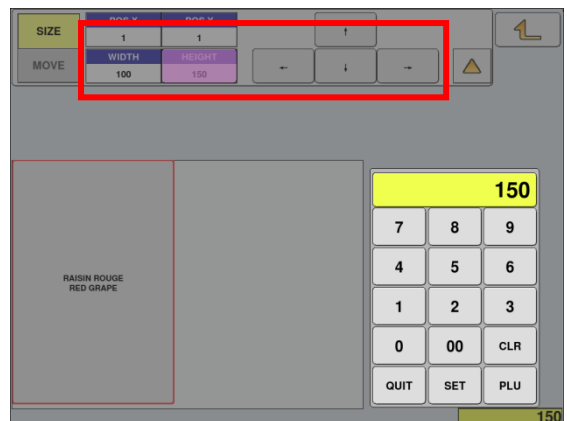

4.5.4 EDITING PRESET KEYS

1. Press the "PRESET KEY" icon on the menu selection screen.



2. The "Preset Key" screen is displayed. Press a desired field for selection, and press the [DETAIL] button.

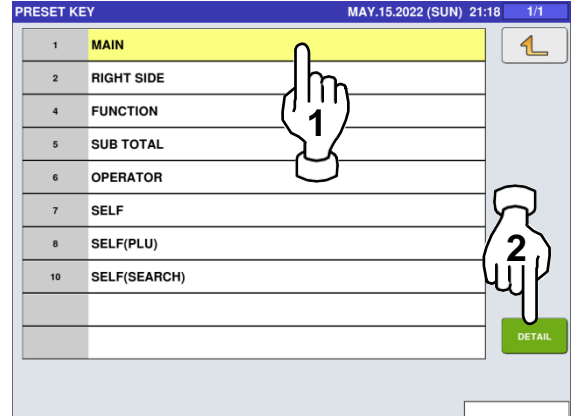

3. Select the group and the page that the preset key you want to edit is located. Then, press the [KEY] button, the preset key, and the [EDIT] button.

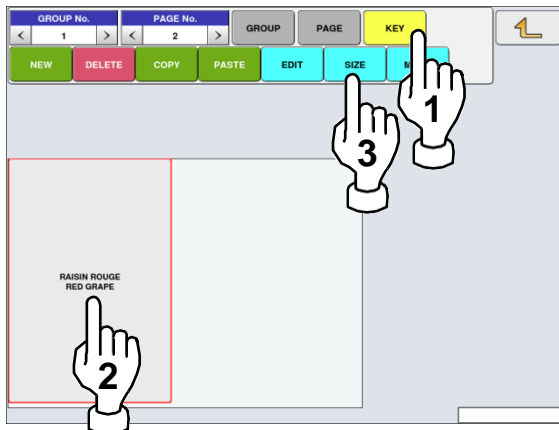

4. The editing screen is displayed.

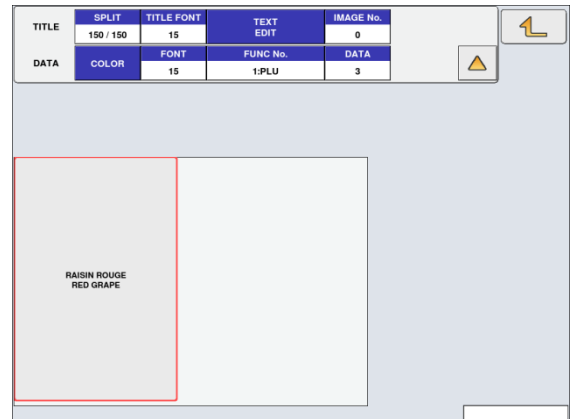

5. To split the preset key display into two portions, press the "SPLIT" field, enter a numerical value, and press the [SET] button on the keypad.

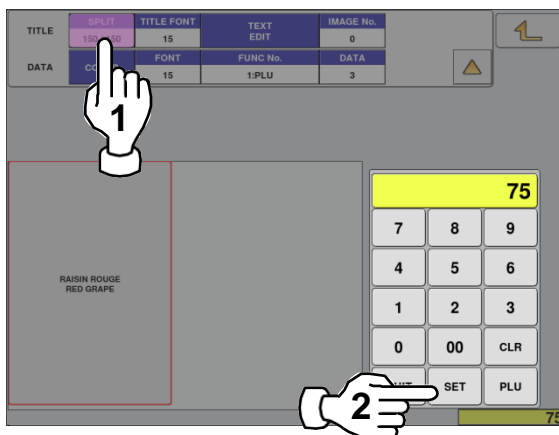

6. The preset key has been split.

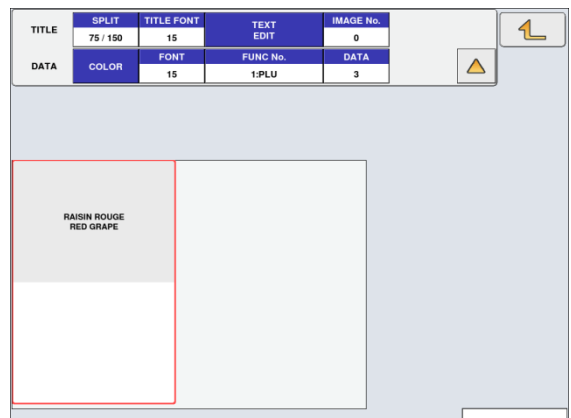

7. To change the font size, press the “TITLE FONT” or “FONT” field, enter a numerical value, and press the [SET] button on the keypad.

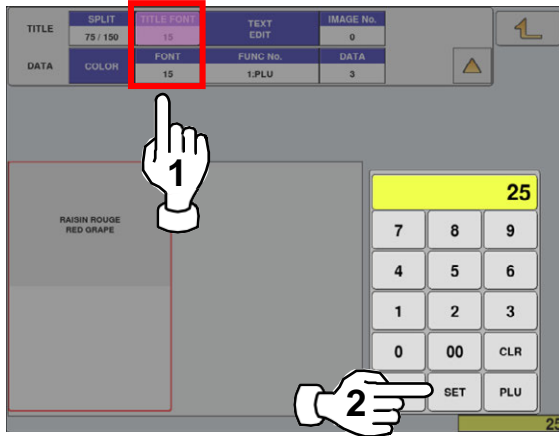

8. The font size has been changed.

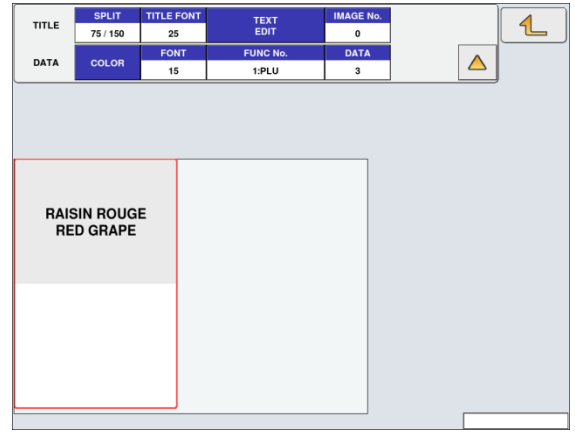

9. To change the preset key title, press the “TEXT EDIT” field.

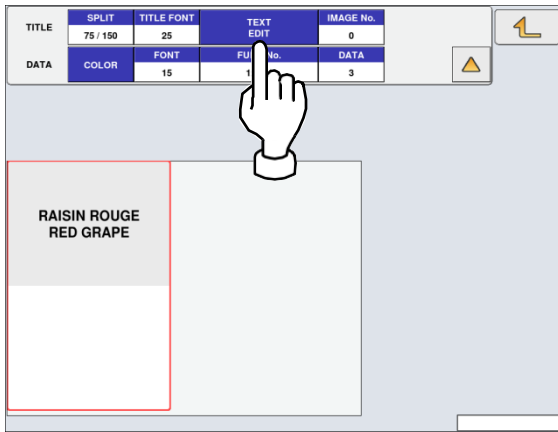

10. The “Preset Key / Name Edit” screen is displayed.

Edit text according to the procedure described in Appendix “Text Editing”.

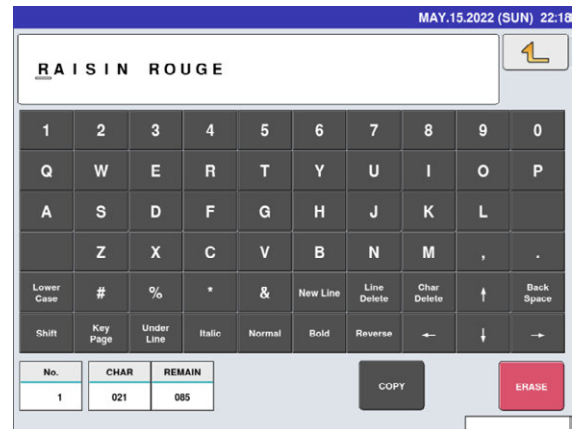

11. To finish the editing, press the Return button.

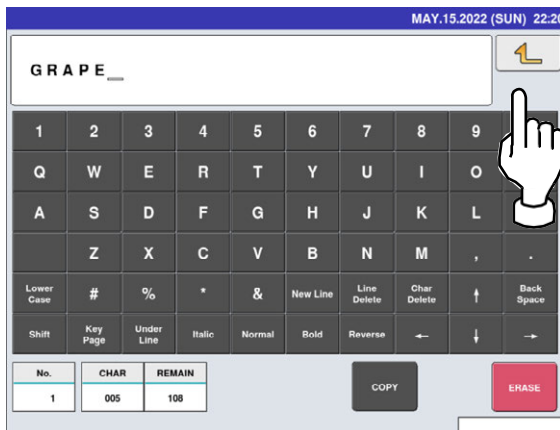

12. The confirmation screen is displayed. To confirm changes, press [SAVE]. To undo changes, press [CANCEL].

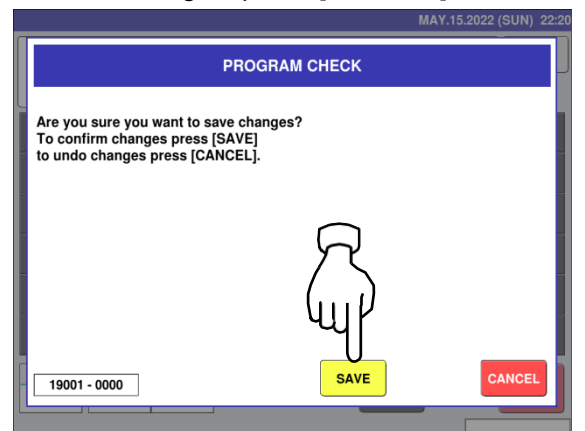

13. To assign a desired image to the preset key, press the "IMAGE No." field.

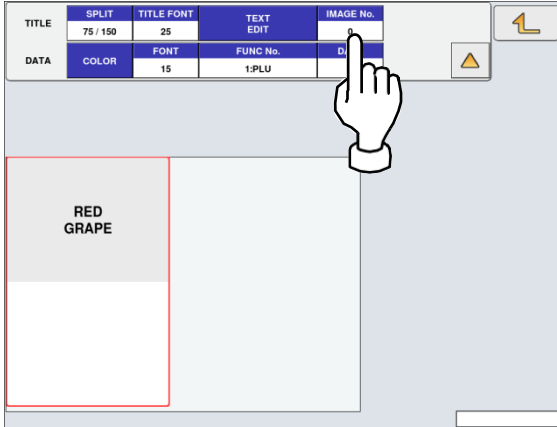

14. The Preset Key / Image screen is displayed. Press a desired image for selection. **Note:** To use images stored in the USB memory, press [STORAGE] key. The movie file with the format of MPEG-4, 800 x 600 (SVGA), 10 Mbps, 25 FPS can also be used. Then, press the [SET] button.

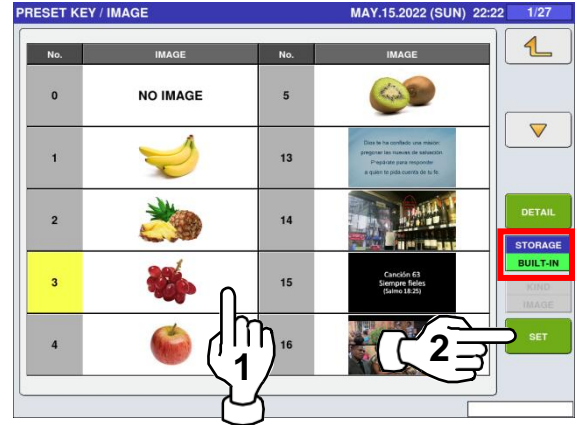

15. The image has been assigned.

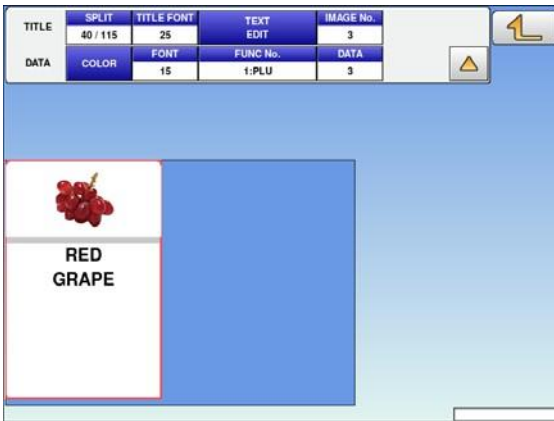

16. To change the color of the preset key, press the [COLOR] button.

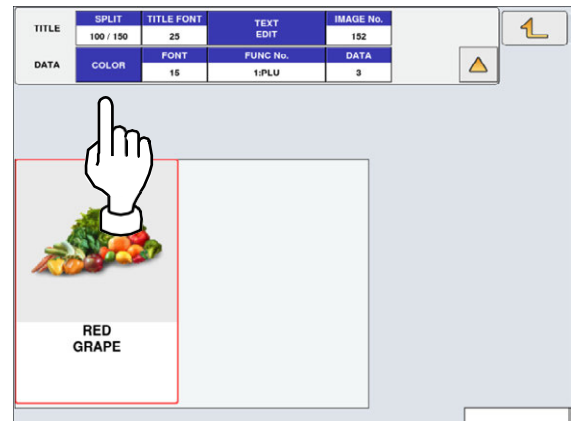

17. The Preset Key / Color screen is displayed.

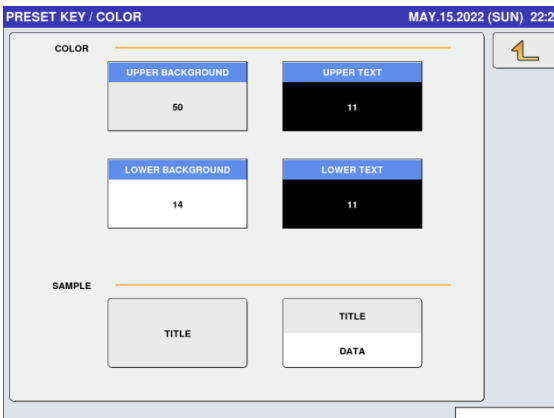

18. To change the background color, press either the "UPPER BACKGROUND" or "LOWER BACKGROUND" field.

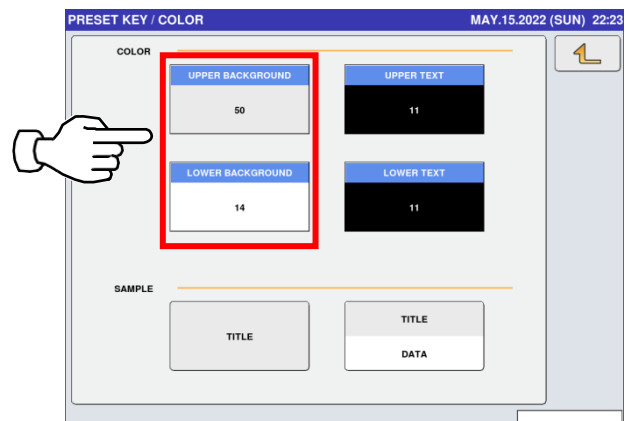

19. Press a desired color for selection.

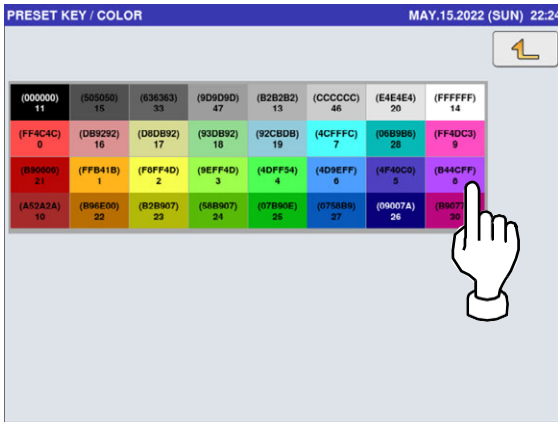

20. The selected color has been applied to the background of the key.

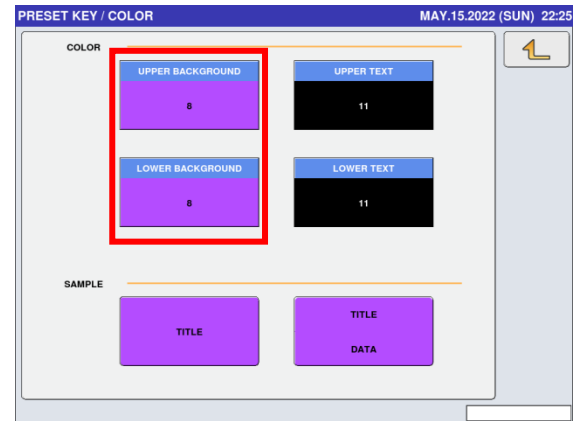

21. To change the font color, press the "UPPER TEXT" or "LOWER TEXT" field.

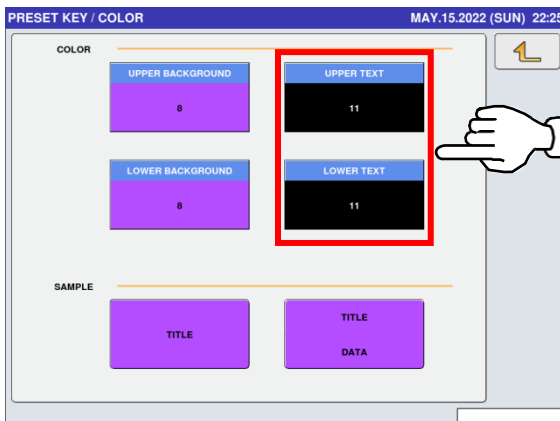

22. Press a desired color for selection.

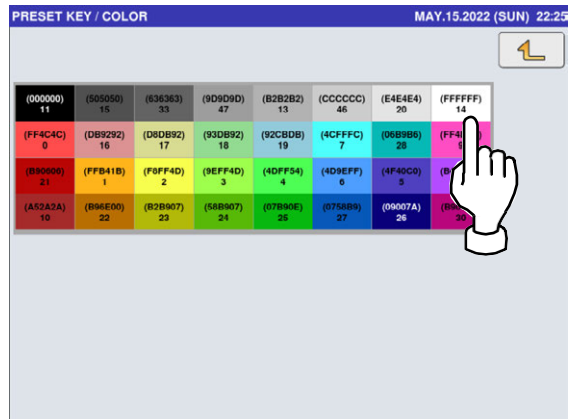

23. The selected color has been applied to the text on the key.

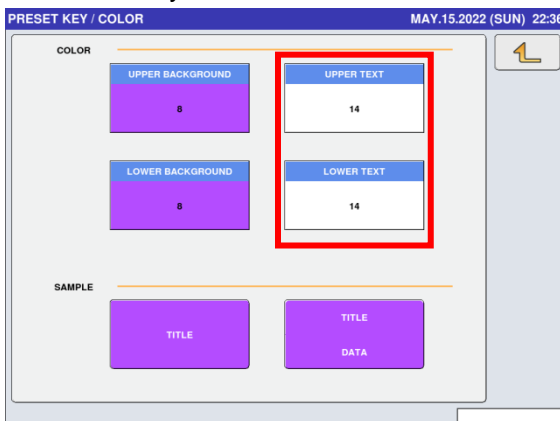

24. To change the preset key operation, press the "FUNC No." field.

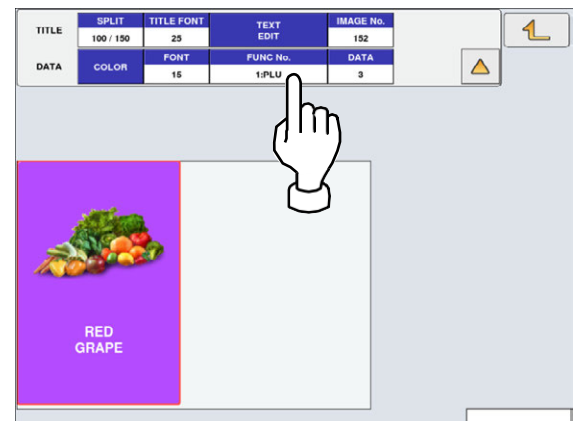

Available functions are listed on the screen.

25. Press a desired function for selection.

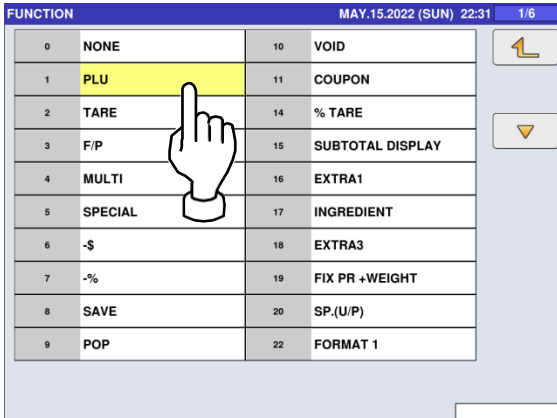

26. To change the PLU number called up by the preset key, press the "DATA" field.

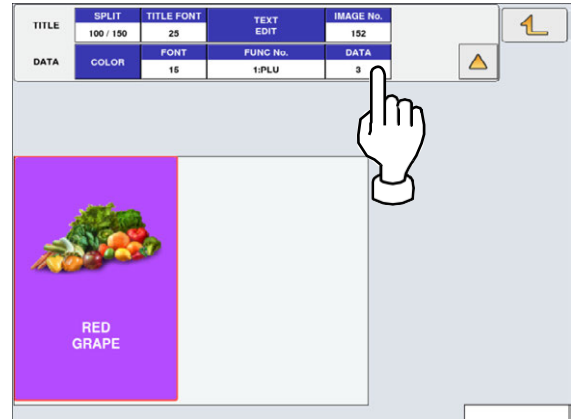

27. The PLU screen is displayed. Then, press a desired field for selection.



28. Upon completion of all settings, press the Return button.

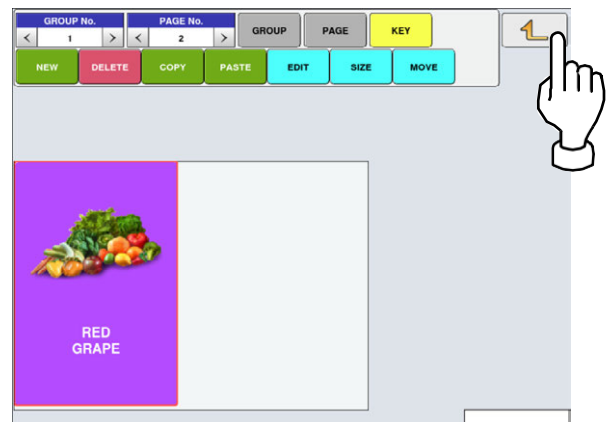

29. The confirmation screen is displayed. Press [EXEC] to continue, or [STOP] to go back.

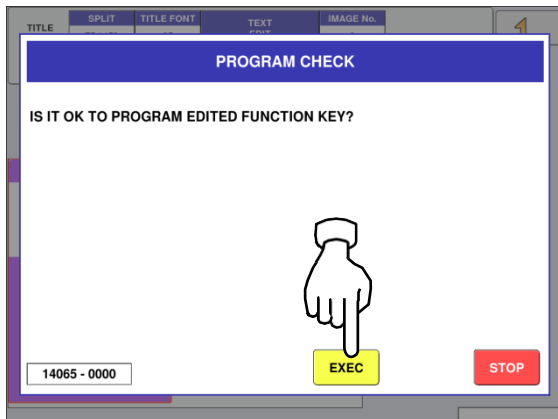

4.5.5 DELETING PRESET KEYS

1. Press the "PRESET KEY" icon on the menu selection screen.

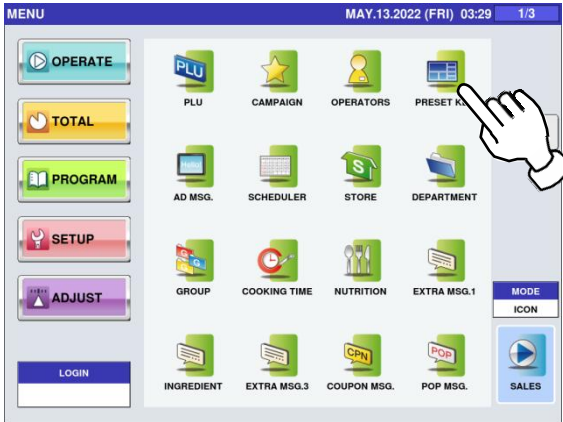

2. The "Preset Key" screen is displayed. Press a desired field for selection, and press the [DETAIL] button.

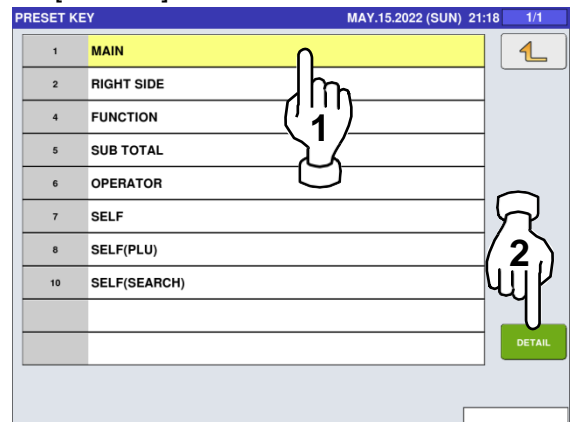

3. Select the group and the page that the preset key you want to delete is located. Then, press the [KEY] button, preset key, and the [DELETE] button.

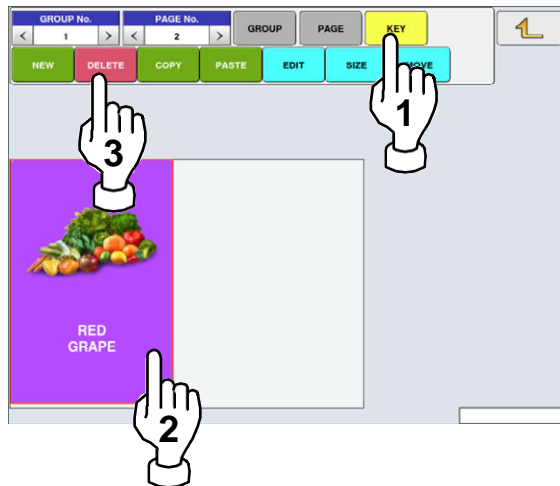

4. The selected key has been deleted.

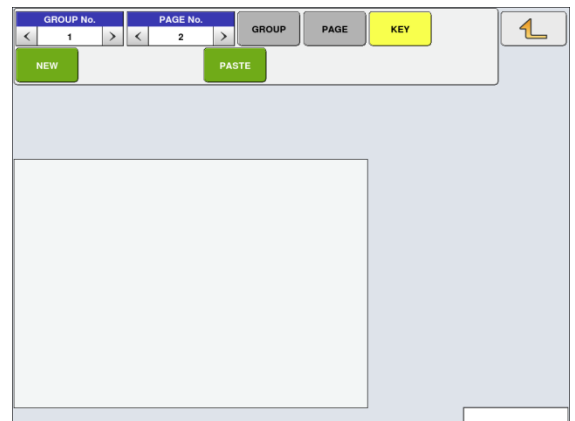

4.6 ADVERTISEMENT MESSAGES

1. Press the “AD MSG.” icon on the menu selection screen.

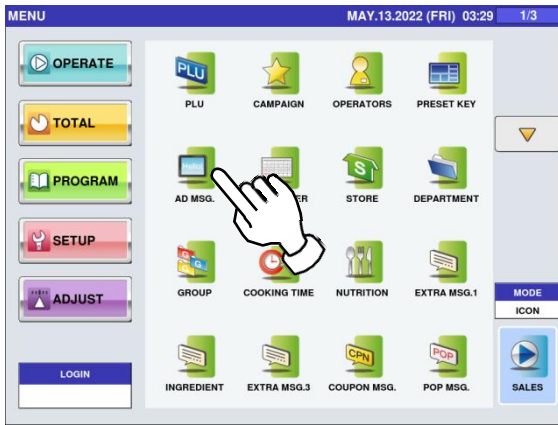

- 2-1 The “Advertisement Message” screen is displayed. To create the first data, press the [NEW] button.

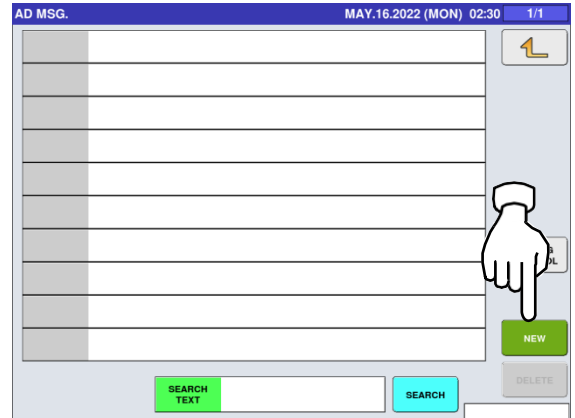

- 2-2 To call up desired data, press the Input field at the bottom right of the screen to display the keypad. Then, enter a numerical value and press the [PLU] key on the keypad.

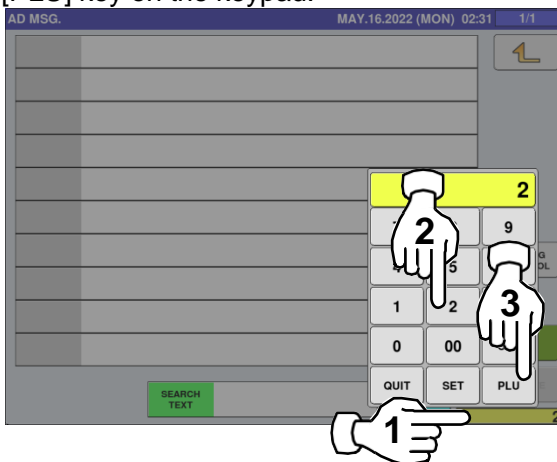

- 2-3 To change existing data, press a desired field for selection and then the [DETAIL] button.

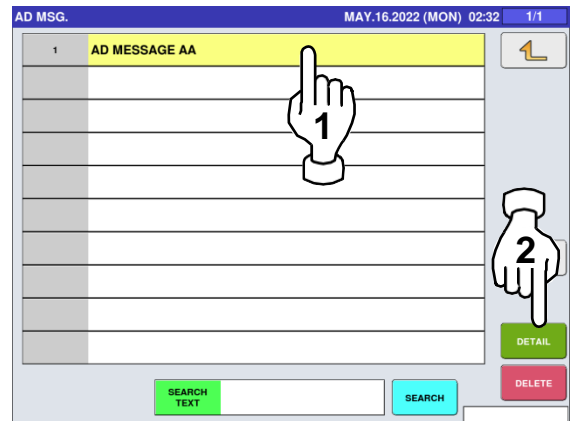

In this case, go to Step 4.

3. If a non-registered item has been called, the confirmation screen is displayed. Press [EXEC] to continue, or [STOP] to go back.

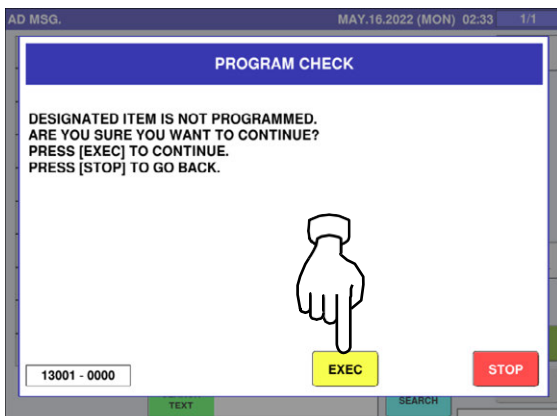

4. The “Advertisement Message / Detail (Text)” screen is displayed. Press the name field.

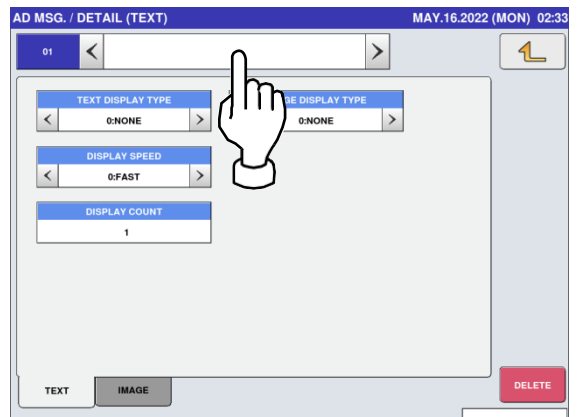

5. The “Advertisement Message / Detail / Edit” screen is displayed.

Edit a desired message according to the procedure described in Appendix “Text Editing”.



6. To exit the edit mode, press the Return button.



7. The confirmation screen is displayed.
To confirm changes, press [SAVE].
To undo changes, press [CANCEL].

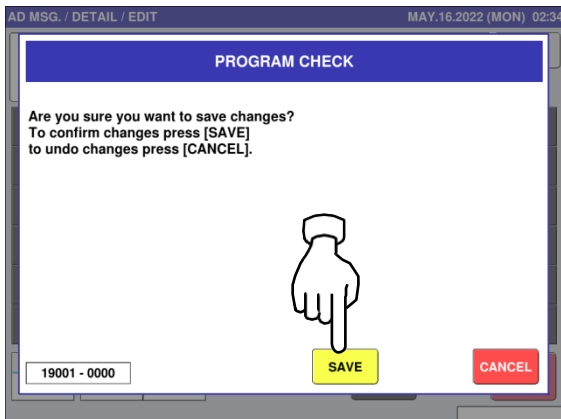

8.

The “Advertisement Message / Detail (Text)” screen is displayed.

The screenshot shows the 'AD MSG. / DETAIL (TEXT)' screen. The title bar at the top indicates the date and time as 'MAY.16.2022 (MON) 02:35'. Below the title bar, there is a navigation bar with '01' on the left, a back arrow, 'AD MESSAGE AA' in the center, a forward arrow, and a yellow 'L' icon on the right. The main content area contains four settings, each in a blue header box with a white background and a white border. The first setting is 'TEXT DISPLAY TYPE' with a value of '0:NONE'. The second is 'IMAGE DISPLAY TYPE' with a value of '0:NONE'. The third is 'DISPLAY SPEED' with a value of '0:FAST'. The fourth is 'DISPLAY COUNT' with a value of '1'. At the bottom of the screen, there are two tabs: 'TEXT' (selected) and 'IMAGE'. A red 'DELETE' button is located at the bottom right.

ITEM	DESCRIPTIONS
TEXT DISPLAY TYPE	Press [] or [] to select a desired text display type.
	0: None 1: Slide 2: Flash
IMAGE DISPLAY TYPE	Press [] or [] to select a desired display type.
	0: None 1: Slide 2: Flash
TEXT DISPLAY SPEED	Press [] or [] to select a desired display speed.
	0: Fast 1: Medium 2: Slow
DISPLAY COUNT	Enter a display count data and press this field.

9. Press the “IMAGE” tab to display the “Advertisement Message / Detail (Image)” screen.

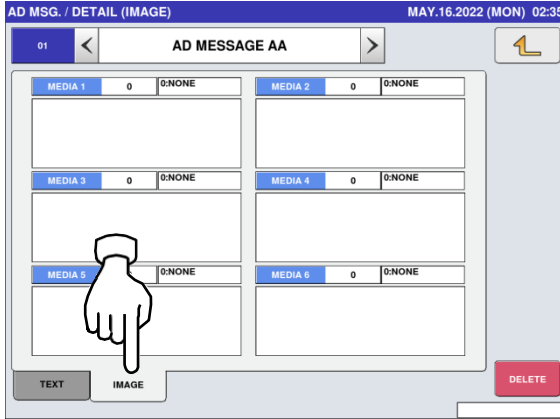

10. Press a desired field to display the Image screen.

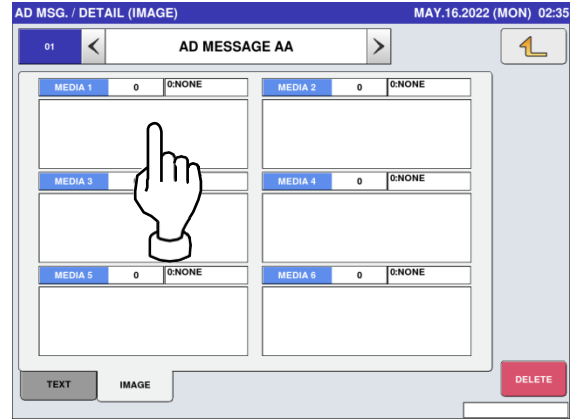

11. The “Advertisement Message / Image” screen is displayed. Press a desired image for selection.

Note: To use images stored in the USB memory, press [STORAGE] key. The movie file with the format of MPEG-4, 800 x 600 (SVGA), 10 Mbps, 25 FPS can also be used. Then, press the [SET] button.

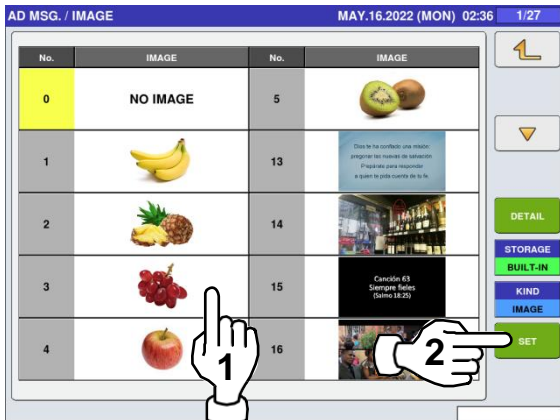

12. The selected image has been assigned in the designated field.

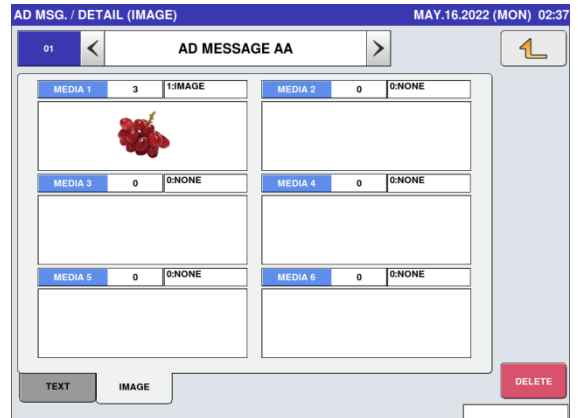

4.7 SCHEDULE DATA

1. Press the "SCHEDULER" icon on the menu selection screen.

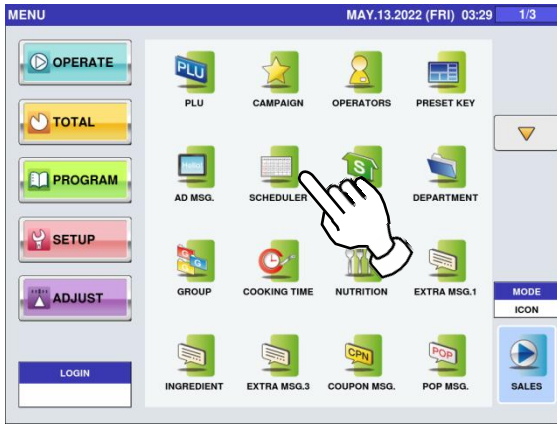

- 2-1 To call up a desired data number, press the Input field at the bottom right of the screen to display the keypad. Then, enter a desired numerical value and press the [PLU] key on the keypad.

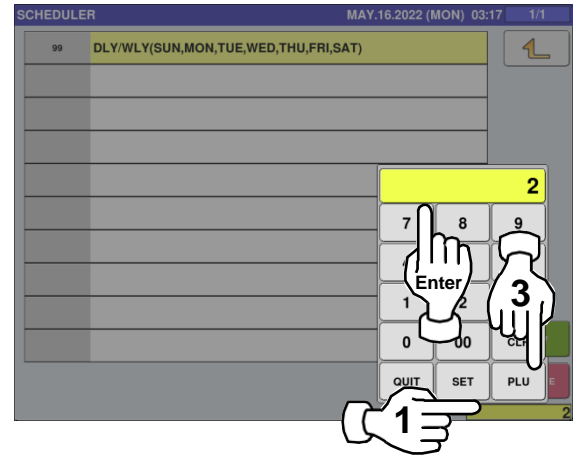

- 2-2 To change existing data, press a desired field for selection and then the [DETAIL] button.

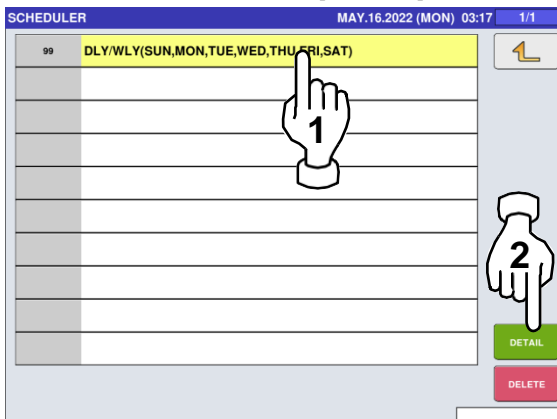

In this case, go to Step 4.

3. If a non-registered item has been called, the confirmation screen is displayed. Press [EXEC] to continue, or [STOP] to go back.

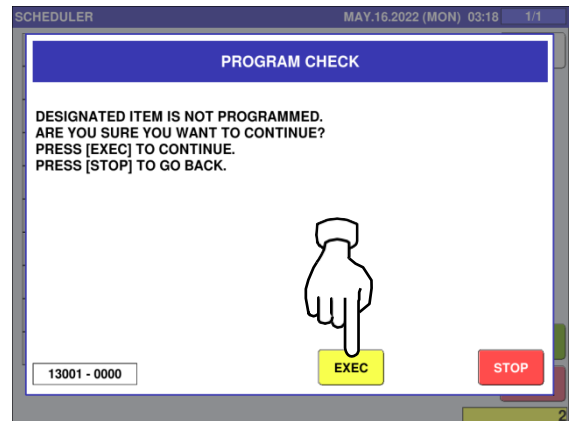

4. The designated Scheduler / Detail (Schedule) screen is displayed. Press [<] or [>] to change the type.

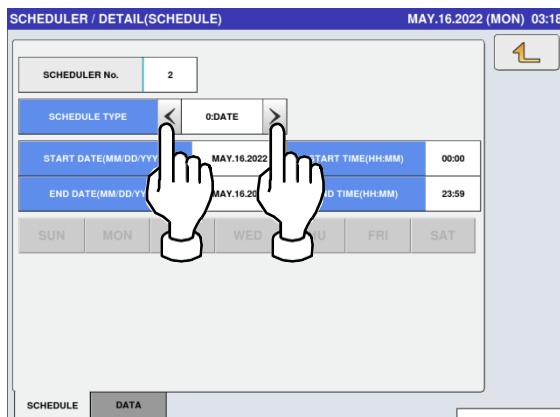

5. To enter the start date, press the "START DATE" field, enter a numerical value, and press the [SET] key on the keypad.

EXAMPLE Start date "June 25, 2022"

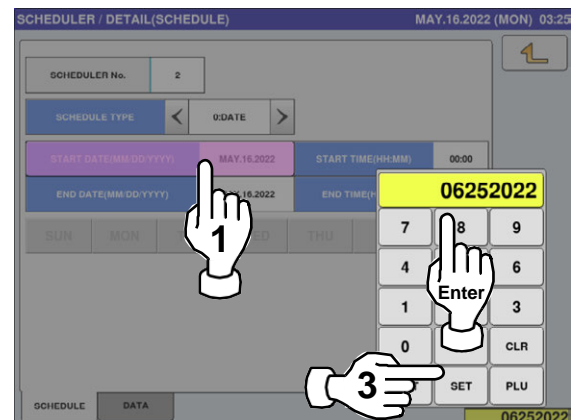

6. To enter the start time, press the “START TIME” field, enter a numerical value, and press the [SET] key on the keypad.

EXAMPLE Start time “08:00”

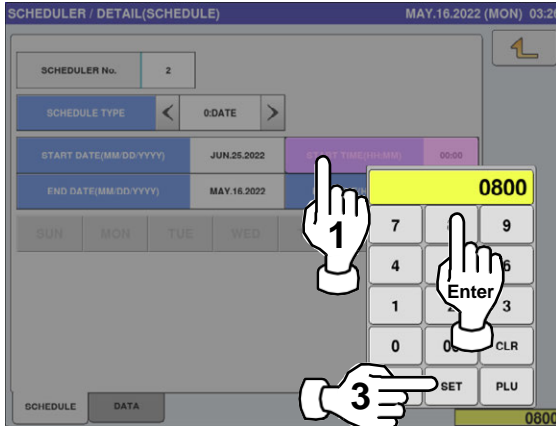

7. To enter the end date, press the “END DATE” field, enter a numerical value, and press the [SET] key on the keypad.

EXAMPLE End date “June 27, 2013”

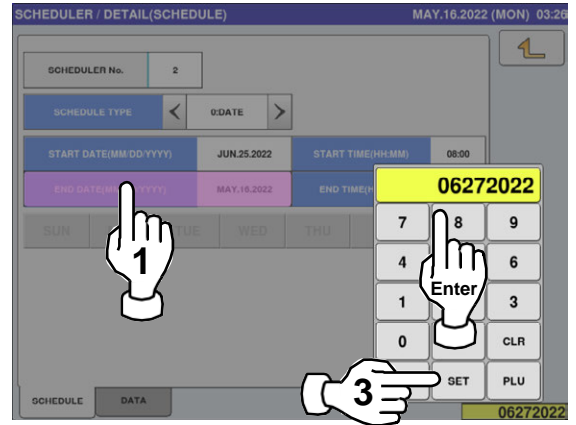

8. To enter the end time, press the “END TIME” field, enter a numerical value, and press the [SET] key on the keypad.

EXAMPLE End time “21:00”

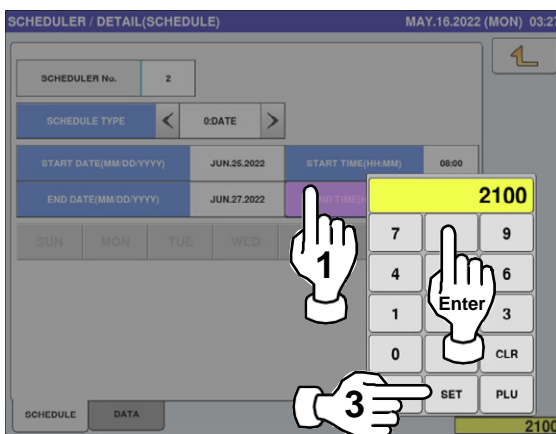

9. When “DLY / WLY” is set in the “SCHEDULE TYPE” field, press a desired day of the week for selection.

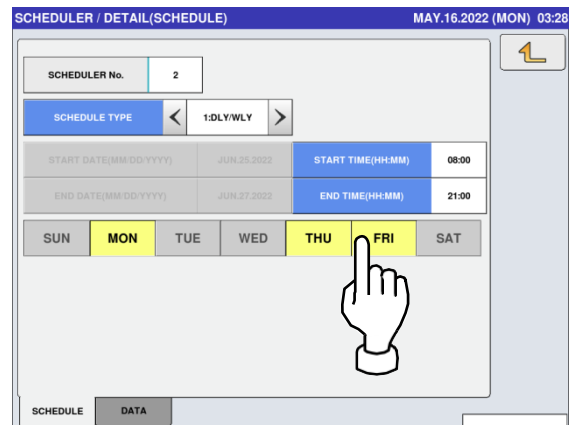

4.8 STORE DATA

1. Press the “STORE” icon on the menu selection screen.



- 2-2 To change existing data, press a desired field for selection and then the [DETAIL] button.

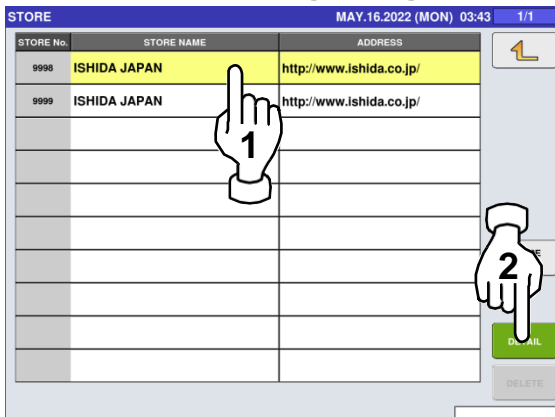

In this case, go to Step 4.

- 2-1 The “Store” screen is displayed. To call up desired data, press the Input field at the bottom right of the screen to display the keypad. Then, enter a numerical value and press the [PLU] key on the keypad.

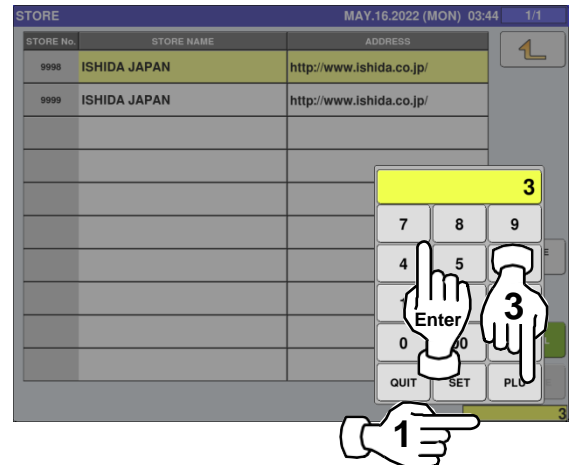

3. If a non-registered item has been called, the confirmation screen is displayed. Press [EXEC] to continue, or [STOP] to go back.

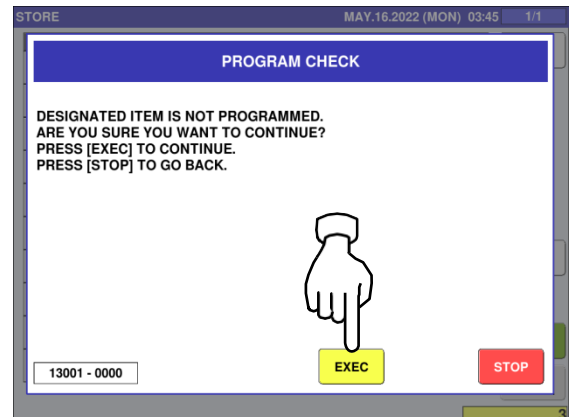

4. The “Store / Detail” screen is displayed.
Press the name field.

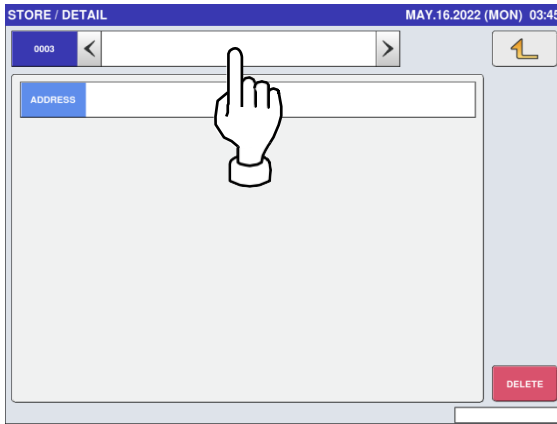

5. The “Store / Name Edit” screen is displayed for the selected store number.
Edit text according to the procedure described in Appendix “Text Editing”.



6. Press the Return button to finish the editing.



7. The confirmation screen is displayed.
To confirm changes, press [SAVE].
To undo changes, press [CANCEL].

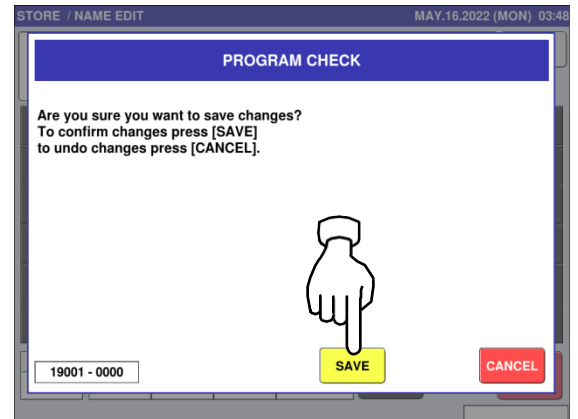

8. The store name has been registered.

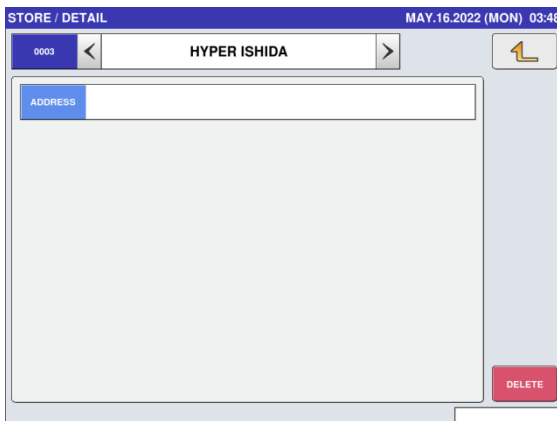

9. To create or change the store address, press the “Address” field.

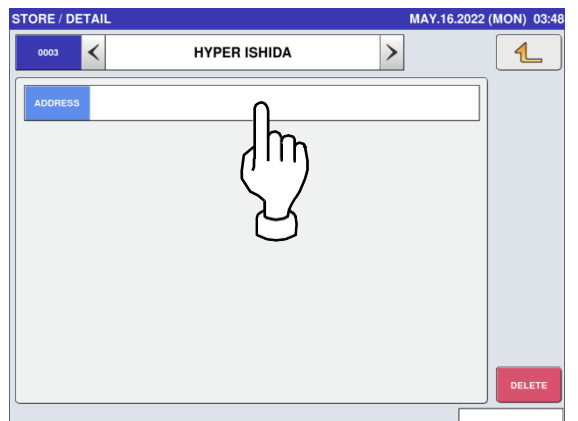

10. The “Store / Edit Address” screen is displayed.
 Edit text according to the procedure described in Appendix “Text Editing”.



11. Press the Return button to finish the editing.



12. The confirmation screen is displayed.
 To confirm changes, press [SAVE].
 To undo changes, press [CANCEL].

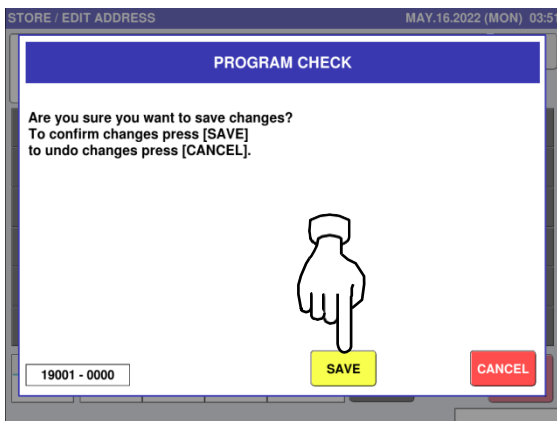

13. The store address has been registered.



4.9 DEPARTMENT NAME DATA

1. Press the “DEPARTMENT” icon on the menu selection screen.

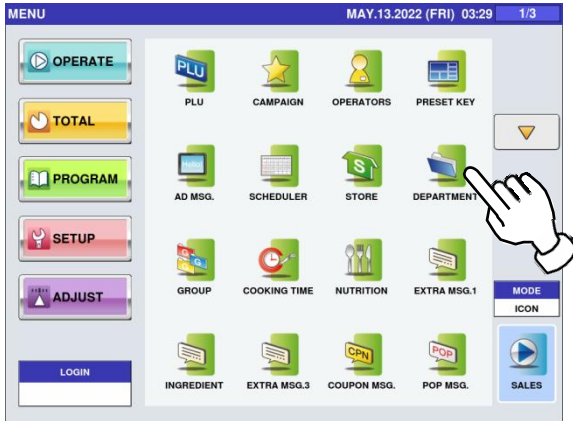

- 2-1 The “Department” screen is displayed. To create the first data, press the [NEW] button.

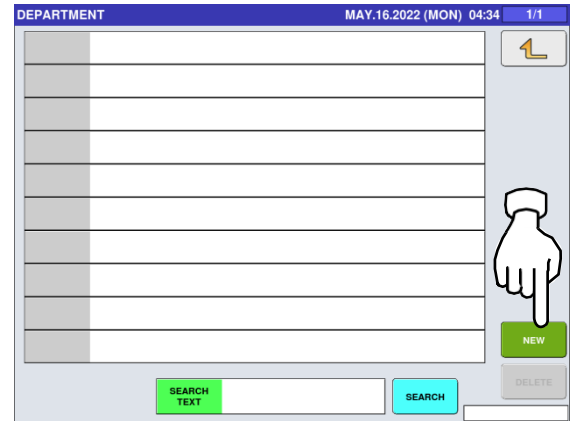

- 2-2 To call up desired data, press the Input field at the bottom right of the screen to display the keypad. Then, enter a numerical value and press the [PLU] key on the keypad.

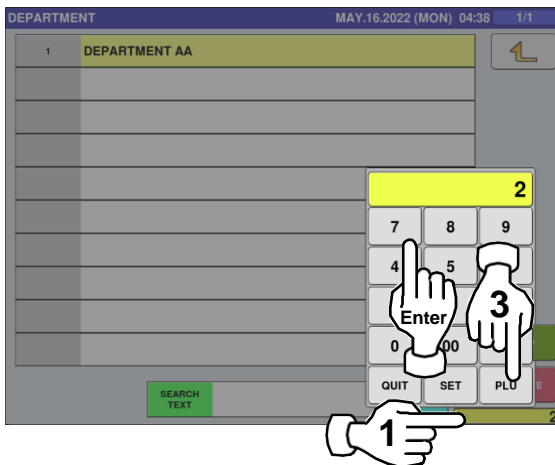

- 2-3 To change existing data, press a desired field for selection and press the [DETAIL] button.

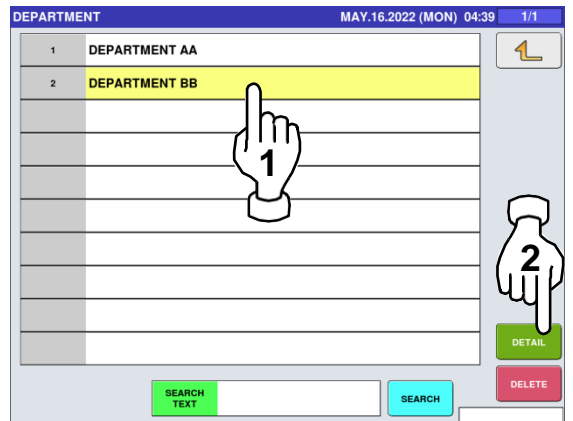

In this case, go to Step 4.

3. If a non-registered item has been called, the confirmation screen is displayed. Press [EXEC] to continue, or [STOP] to go back.

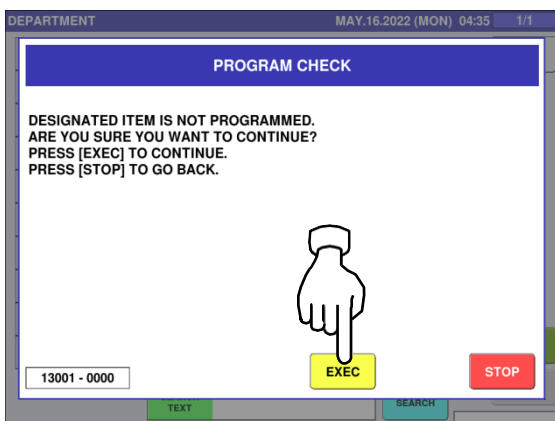

4. The “Department / Edit” screen is displayed. Edit text according to the procedure described in Appendix “Text Editing”.

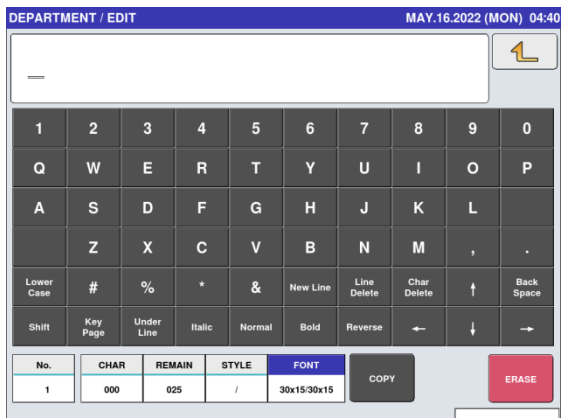

5. Press the Return button to finish the editing.

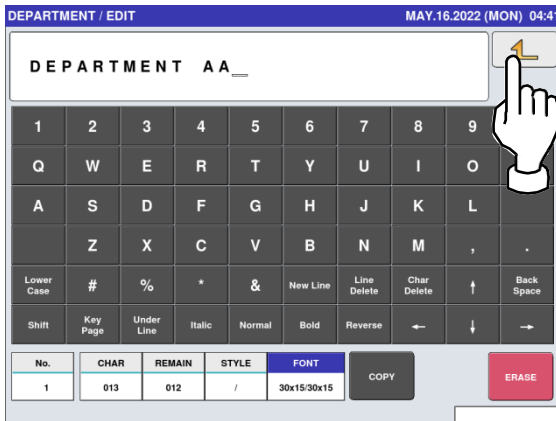

6. The confirmation screen is displayed. To confirm changes, press [SAVE]. To undo changes, press [CANCEL].

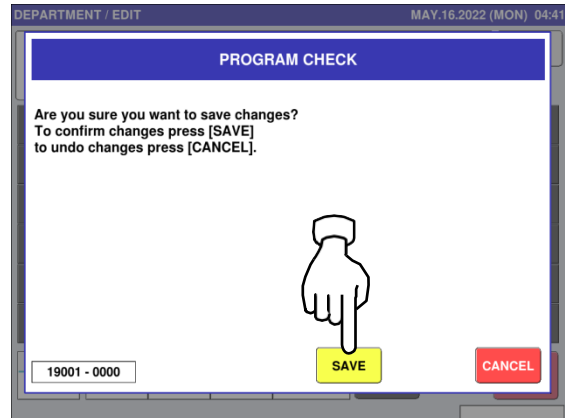

7. The edited data has been registered.

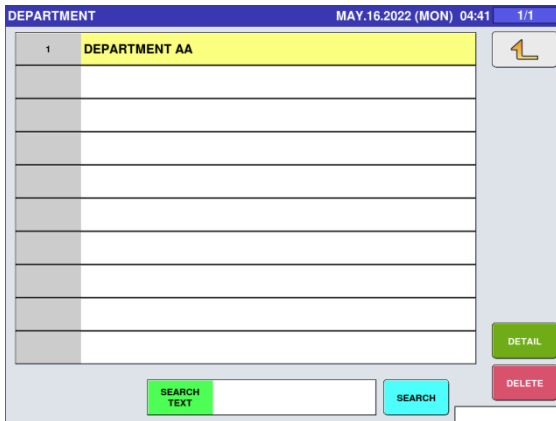

4.10 GROUP NAME DATA

1. Press the "GROUP" icon on the menu selection screen.



- 2-1 The "Group" screen is displayed. To create the first data, press the [NEW] button.

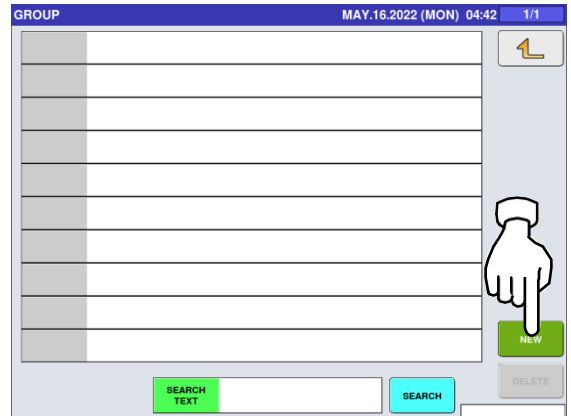

- 2-2 To call up desired data, press the Input field at the bottom right of the screen to display the keypad. Then, enter a numerical value and press the [PLU] key on the keypad.

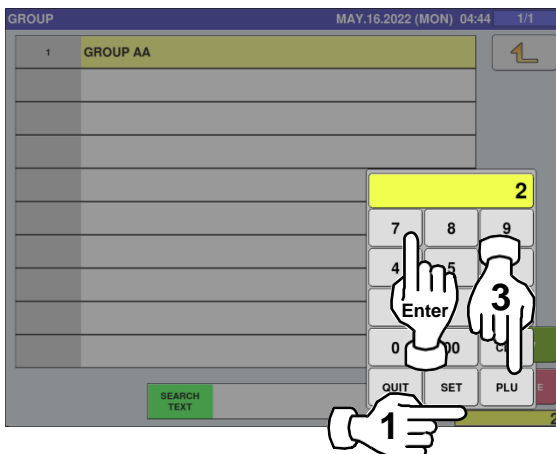

- 2-3 To change existing data, press a desired field for selection and then the [DETAIL] button.

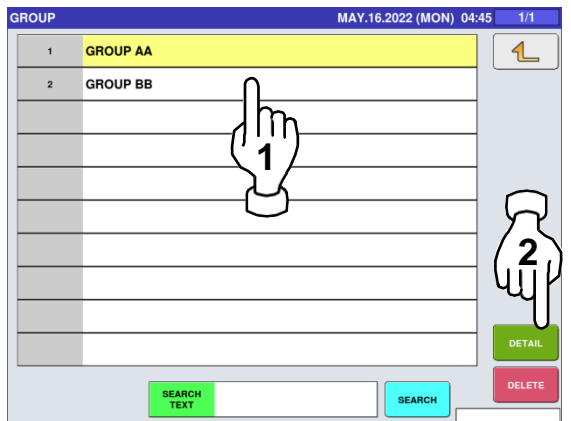

In this case, go to Step 4.

3. If a non-registered item has been called, the confirmation screen is displayed. Press [EXEC] to continue, or [STOP] to go back.

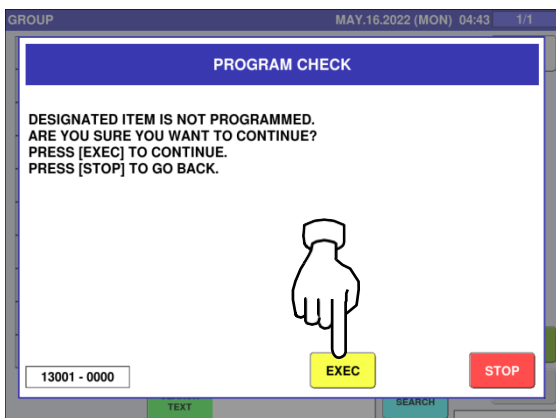

4. The "Group / Edit" screen is displayed. Edit the text according to the procedure described in Appendix "Text Editing".

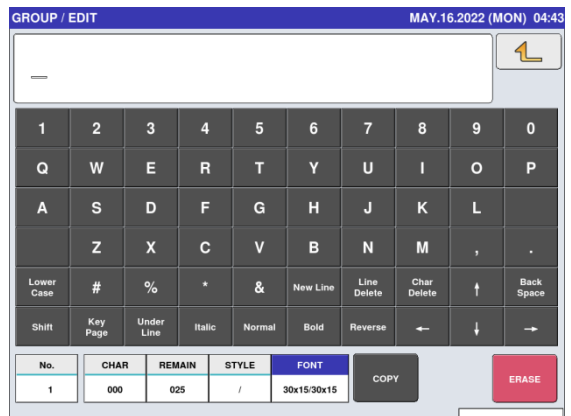

5. Press the Return button to finalize the edited text.



6. The confirmation screen appears. Press [EXEC] to continue, or [STOP] to go back.

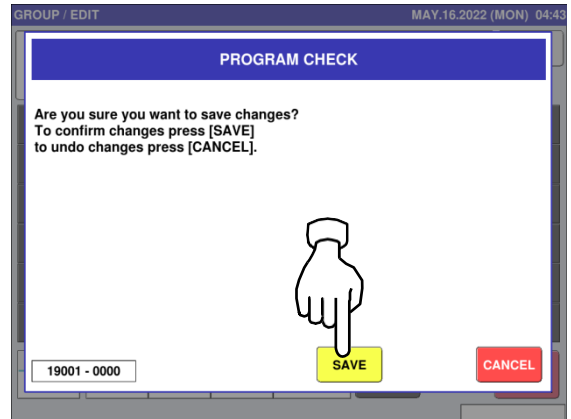

7. The edited data has been registered.

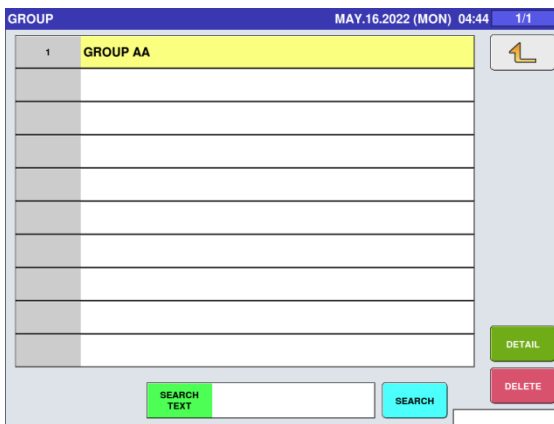

4.11 COOKING INSTRUCTION DATA

1. Press the "COOKING TIME" icon on the menu selection screen.



- 2-1 The "Cooking Time" screen is displayed. To create the first data, press the [NEW] button.

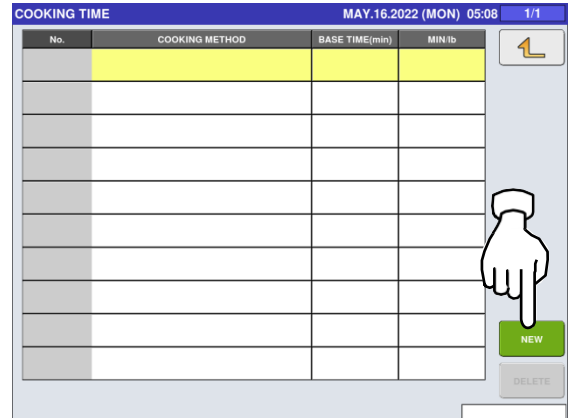

- 2-2 To call up desired data, press the Input field at the bottom right of the screen to display the keypad. Then, enter a numerical value and press the [PLU] key on the keypad.

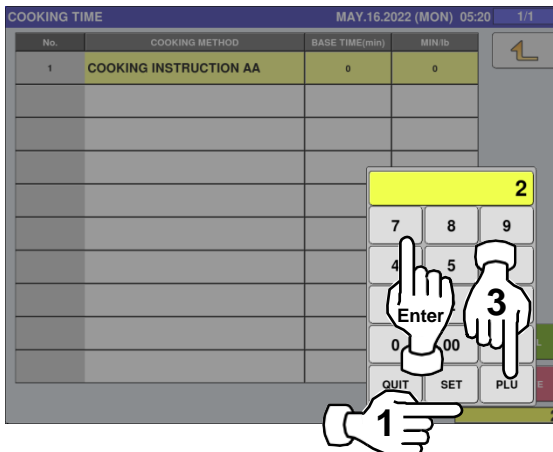

- 2-3 To change existing data, press a desired field for selection and then the [DETAIL] button.

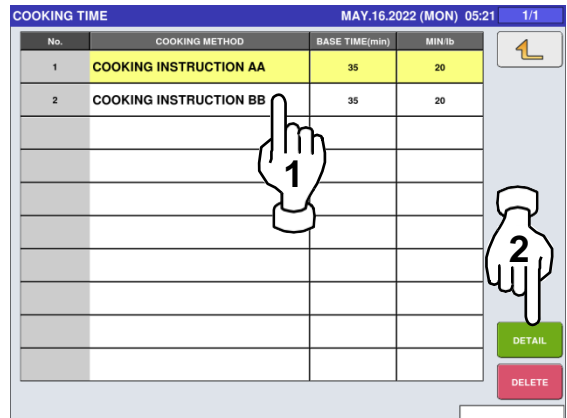

In this case, go to Step 4.

3. If a non-registered item has been called, the confirmation screen is displayed. Press [EXEC] to continue, or [STOP] to go back.

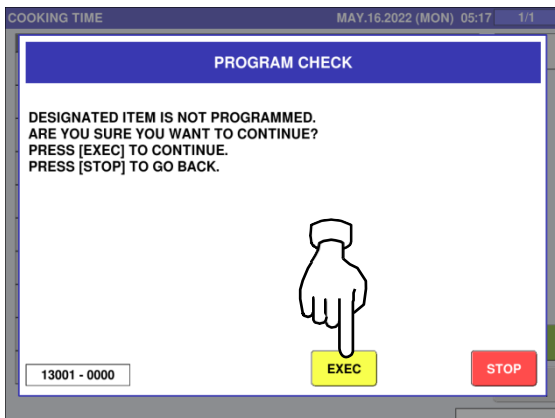

4. The "Cooking Time / Edit" screen is displayed. Edit text according to the procedure described in Appendix "Text Editing".

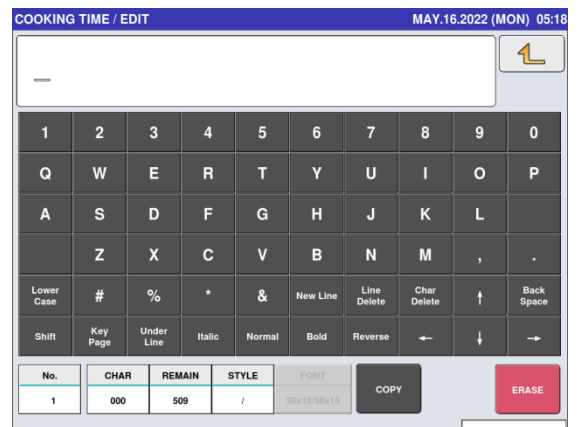

5. Press the Return button to finish the editing.

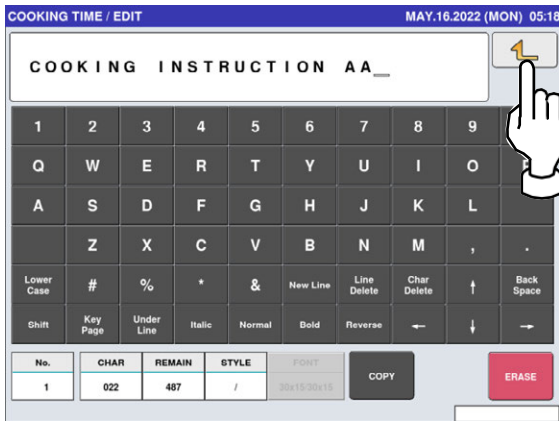

6. The confirmation screen is displayed. To confirm changes, press [SAVE]. To undo changes, press [CANCEL].

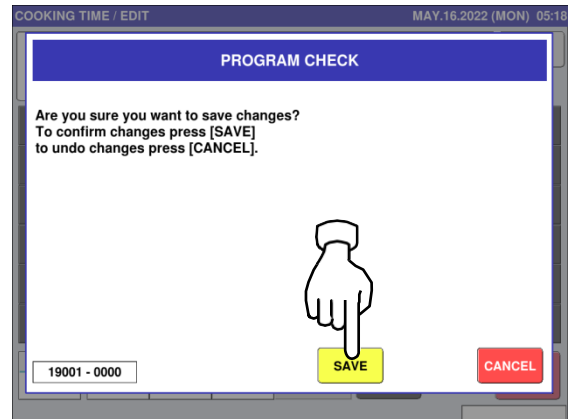

7. The edited data has been registered.

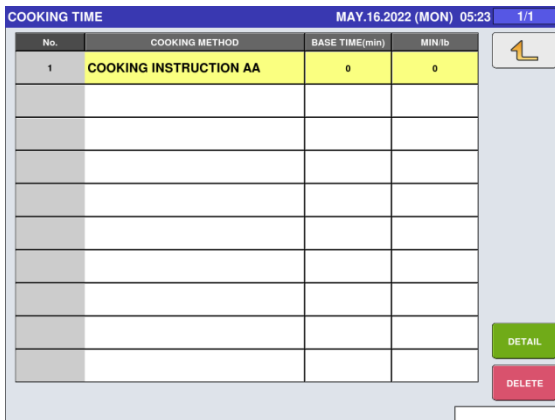

8. Press the Input field at the bottom right of the screen to display the keypad. Enter a numerical value via the keypad and press the applicable field.

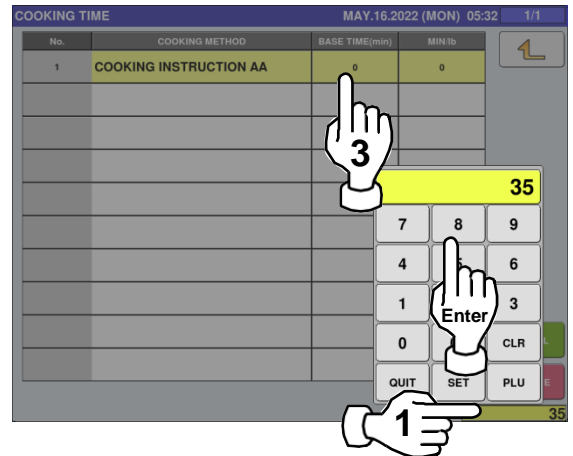

9. The edited data has been registered.

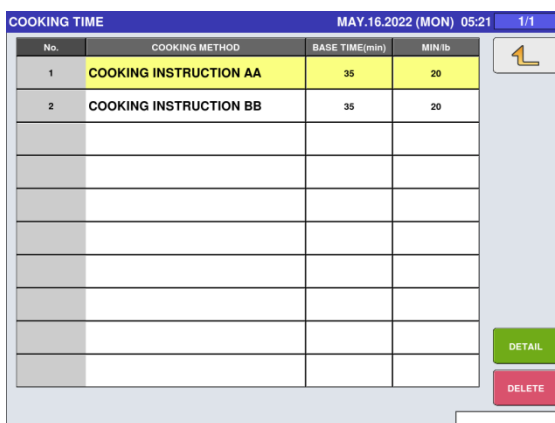

4.12 EXTRA MESSAGE DATA

1. Press the “EXTRA MSG.” icon on the menu selection screen.



- 2-1 The “Extra Message” screen is displayed. To create the first data, press the [NEW] button.

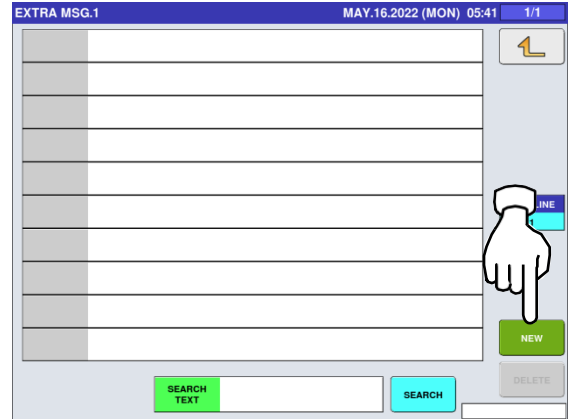

- 2-2 To call up a desired data number, press the Input field at the bottom right of the screen to display the keypad. Then, enter a desired numerical value and press the [PLU] key on the keypad.

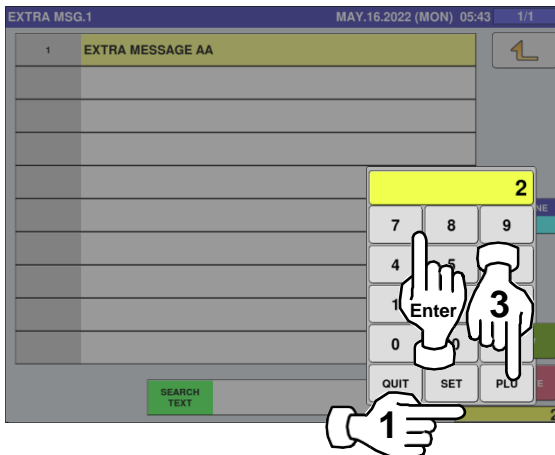

- 2-3 To change existing data, press a desired field for selection and then the [DETAIL] button.

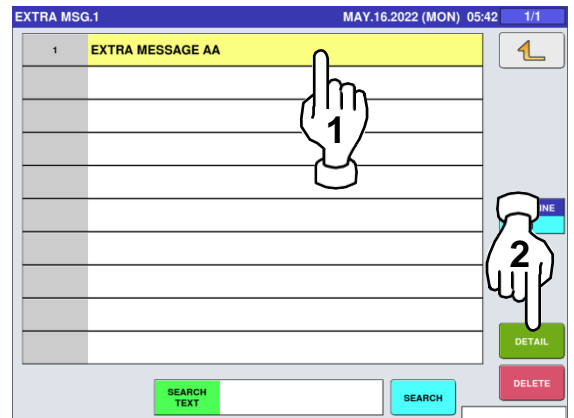

In this case, go to Step 4.

3. If a non-registered item has been called, the confirmation screen is displayed. Press [EXEC] to continue, or [STOP] to go back.

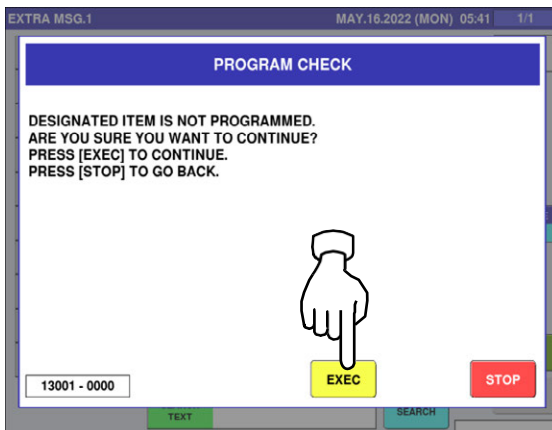

4. The “Extra Message / Edit” screen is displayed. Edit text according to the procedure described in Appendix “Text Editing”.

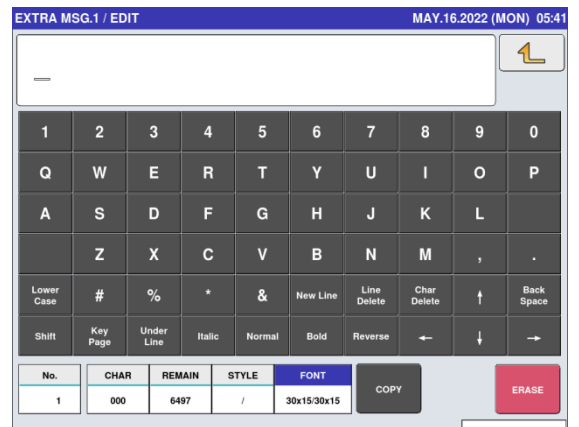

5. Press the Return button to finish the editing.

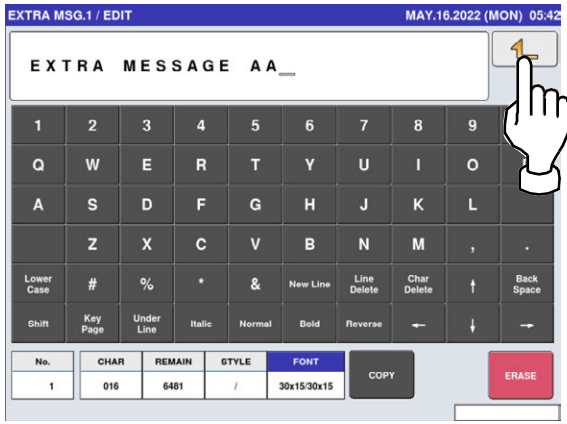

6. The confirmation screen is displayed. To confirm changes, press [SAVE]. To undo changes, press [CANCEL].

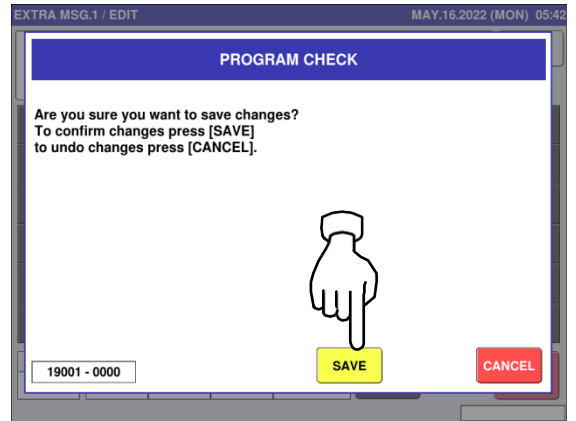

7. The edited data has been registered.



4.13 COUPON MESSAGE DATA

- 1.** Press the “COUPON MSG.” icon on the menu selection screen.

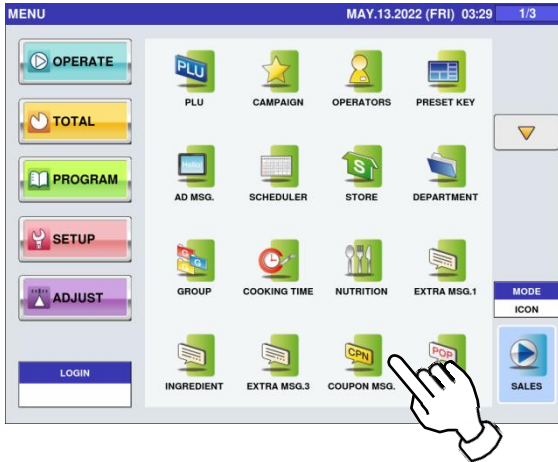

- 2-1** The “Coupon Message” screen is displayed. To create the first data, press the [NEW] button.

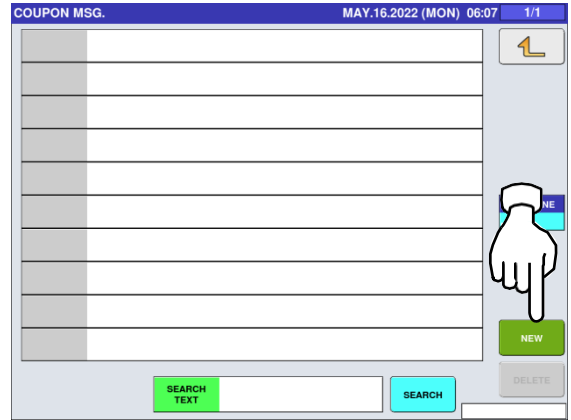

- 2-2** To call up desired data, press the Input field at the bottom right of the screen to display the keypad. Then, enter a numerical value and press the [PLU] key on the keypad.

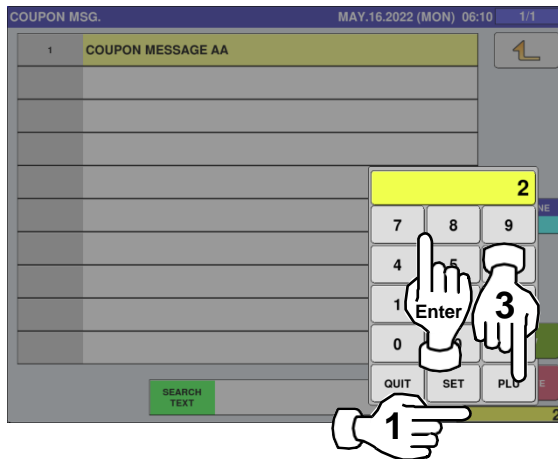

- 2-3** To change existing data, press a desired field for selection and then the [DETAIL] button.

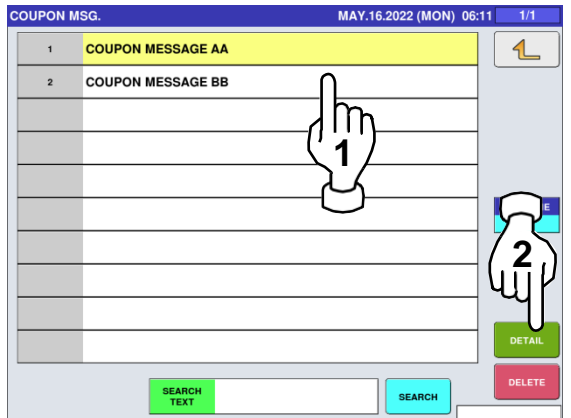

In this case, go to Step 4.

- 3.** If a non-registered item has been called, the confirmation screen is displayed. Press [EXEC] to continue, or [STOP] to go back.

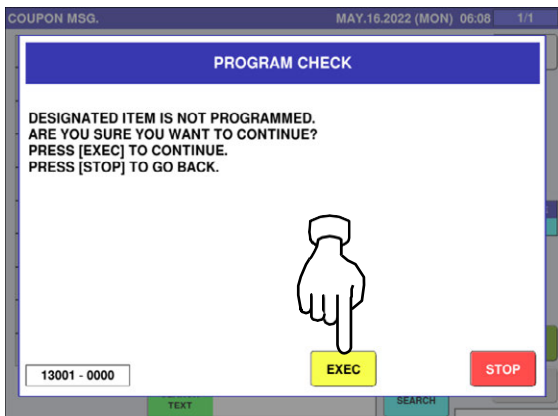

- 4.** The “Coupon Message / Edit” screen is displayed. Edit text according to the procedure described in Appendix “Text Editing”.

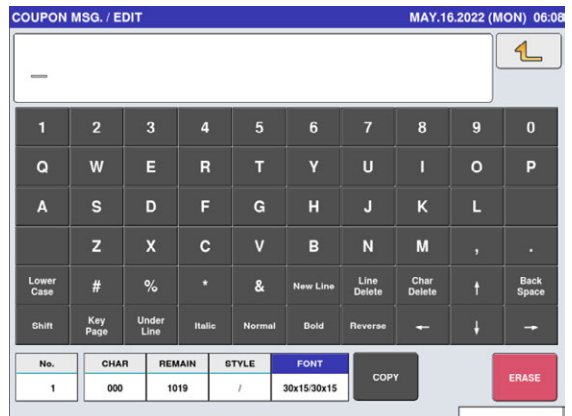

5. Press the Return button to finish the editing.



6. The confirmation screen is displayed. To confirm changes, press [SAVE]. To undo changes, press [CANCEL].

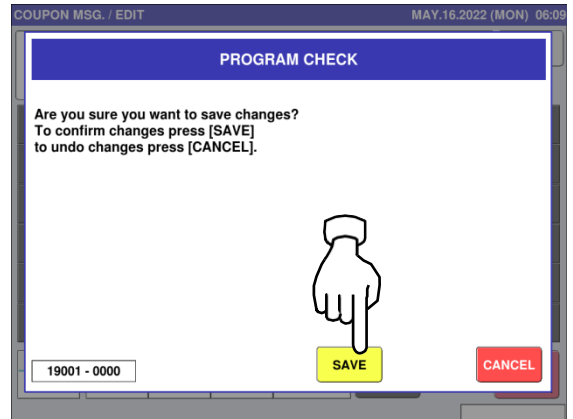

7. The edited data has been registered.

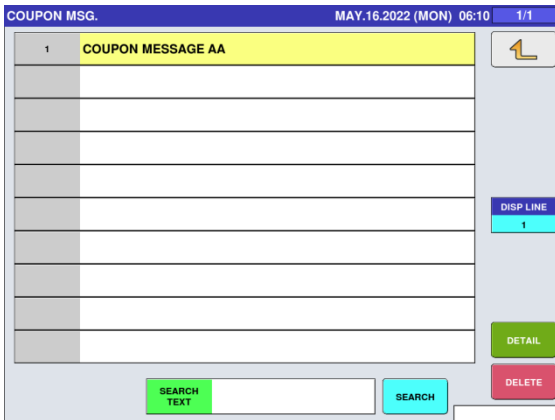

4.14 POP MESSAGE DATA

1. Press the "POP MSG." icon on the menu selection screen.

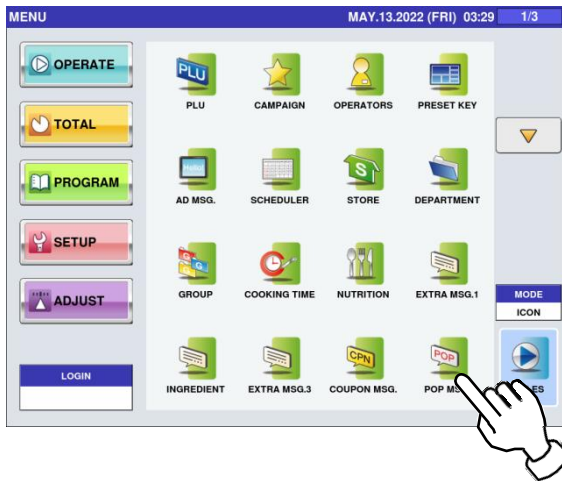

- 2-1 The "POP Message" screen is displayed. To create the first data, press the [NEW] button.

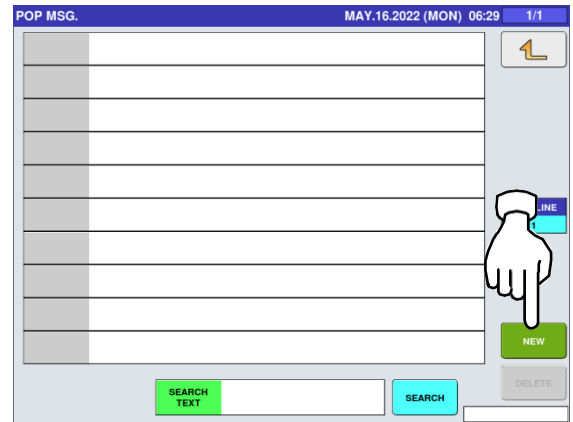

- 2-2 To call up desired data, press the Input field at the bottom right of the screen to display the keypad. Then, enter a numerical value and press the [PLU] key on the keypad.

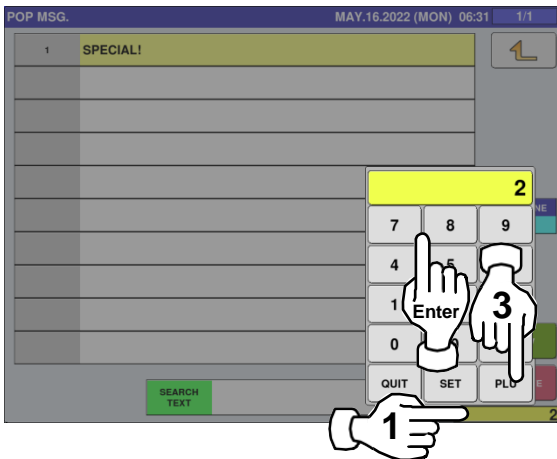

- 2-3 To change existing data, press a desired field for selection and then the [DETAIL] button.

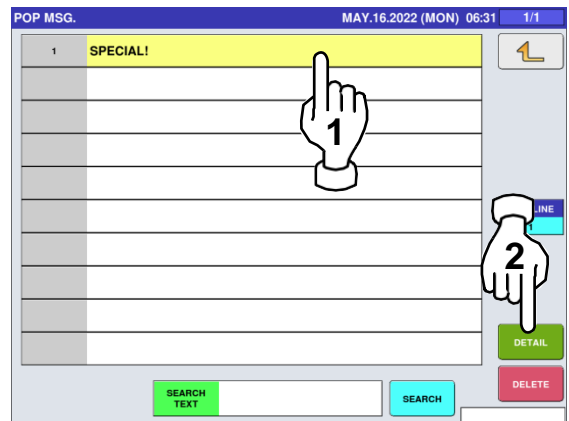

In this case, go to Step 4.

3. If a non-registered item has been called, the confirmation screen is displayed. Press [EXEC] to continue, or [STOP] to go back.

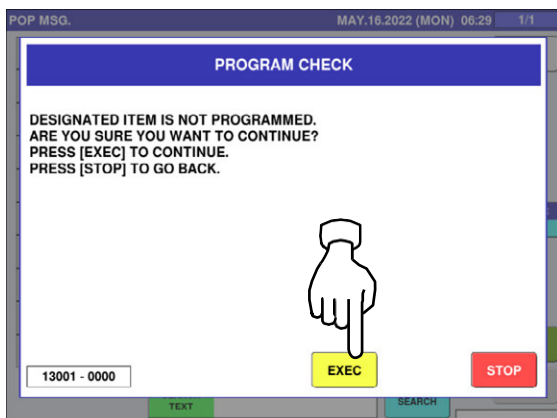

4. The "POP Message / Edit" screen is displayed. Edit text according to the procedure described in Appendix "Text Editing".

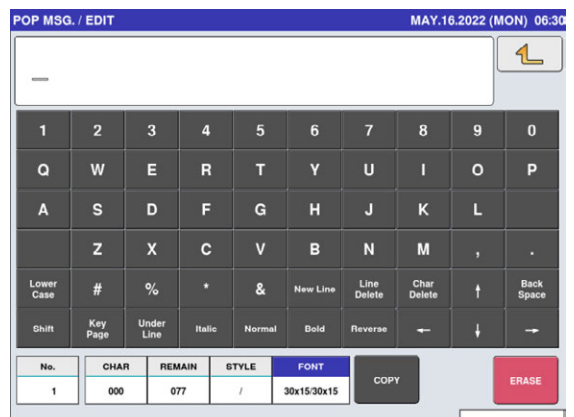

5. Press the Return button to finish the editing.

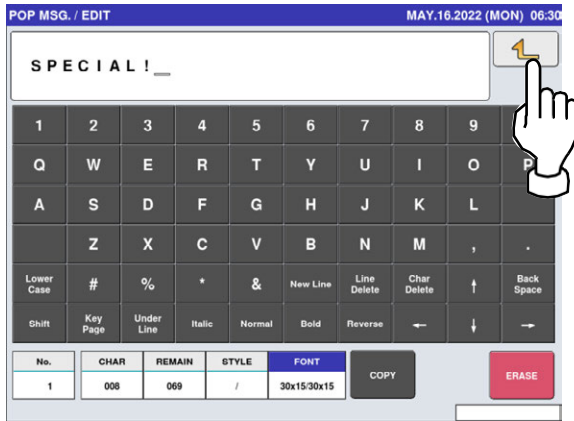

6. The confirmation screen is displayed. To confirm changes, press [SAVE]. To undo changes, press [CANCEL].

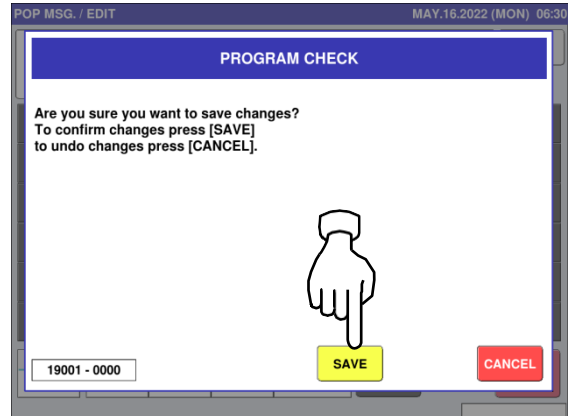

7. The edited data has been registered.

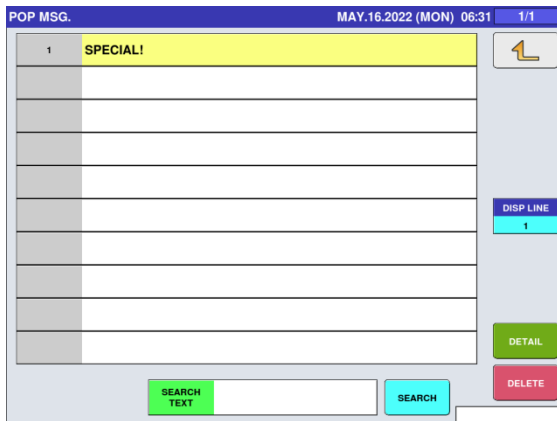

4.15 SCHEME TABLE DATA

1. Press the "SCHEME TABLE" icon on the menu selection screen.

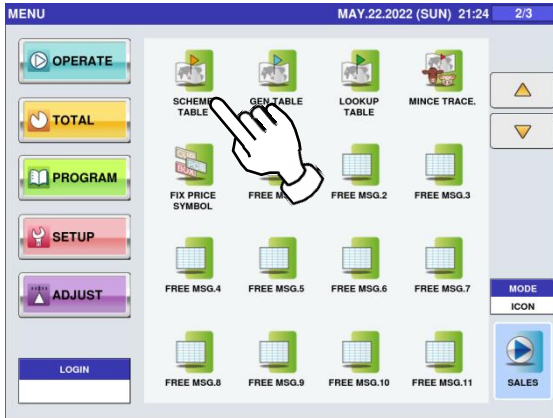

- 2-1 The "Scheme Table" screen is displayed. To create the first data, press the [NEW] button.

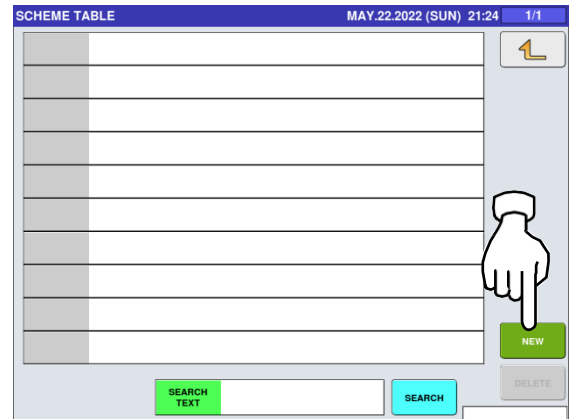

- 2-2 To call up desired data, press the Input field at the bottom right of the screen to display the keypad. Then, enter a numerical value and press the [PLU] key on the keypad.

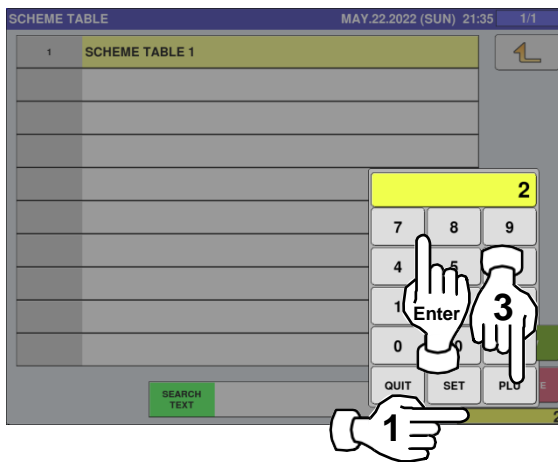

- 2-3 To change existing data, press a desired field for selection and then the [DETAIL] button.

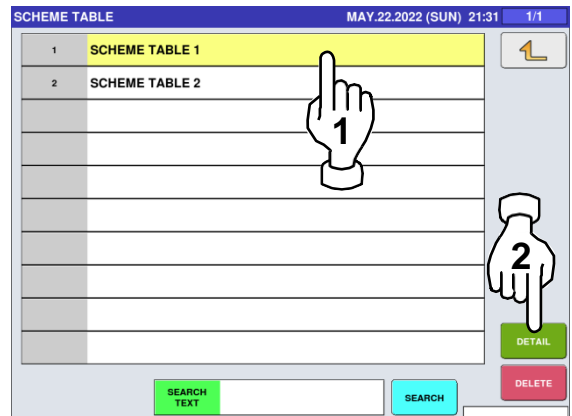

In this case, go to Step 4.

3. If a non-registered item has been called, the confirmation screen is displayed. Press [EXEC] to continue, or [STOP] to go back.

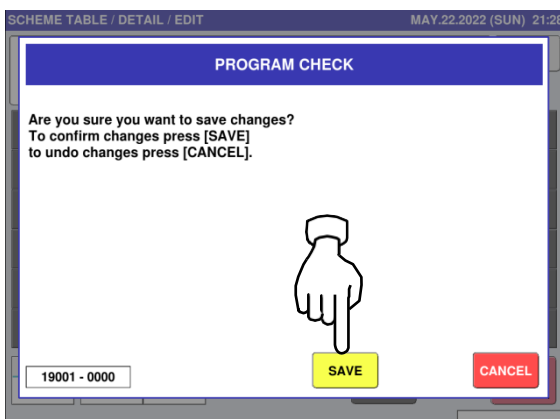

4. The "Scheme Table / Detail (Control)" screen is displayed.

Press the name field.

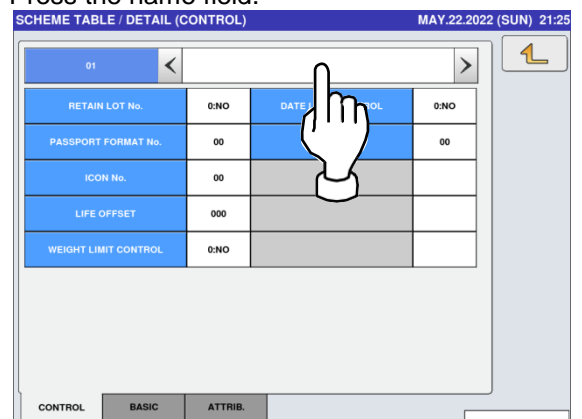

5. The "Scheme Table / Edit screen" is displayed.
 Edit text according to the procedure described in Appendix "Text Editing".



6. Press the Return button to finish the editing.

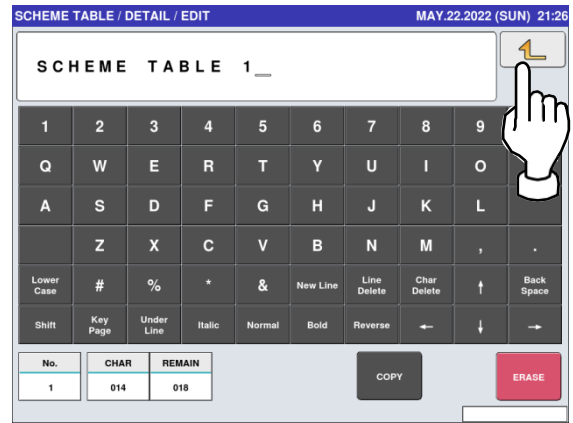

7. The confirmation screen is displayed.
 To confirm changes, press [SAVE].
 To undo changes, press [CANCEL].

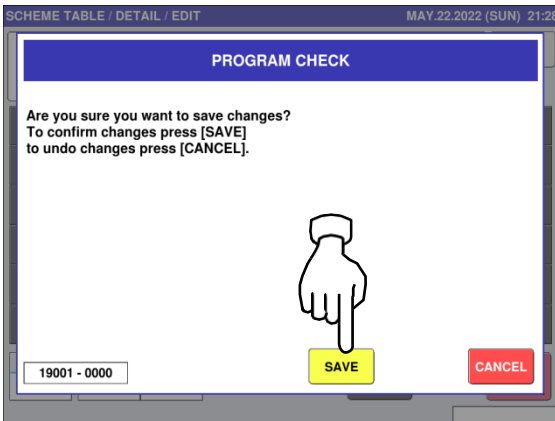

8. The edited data has been registered.

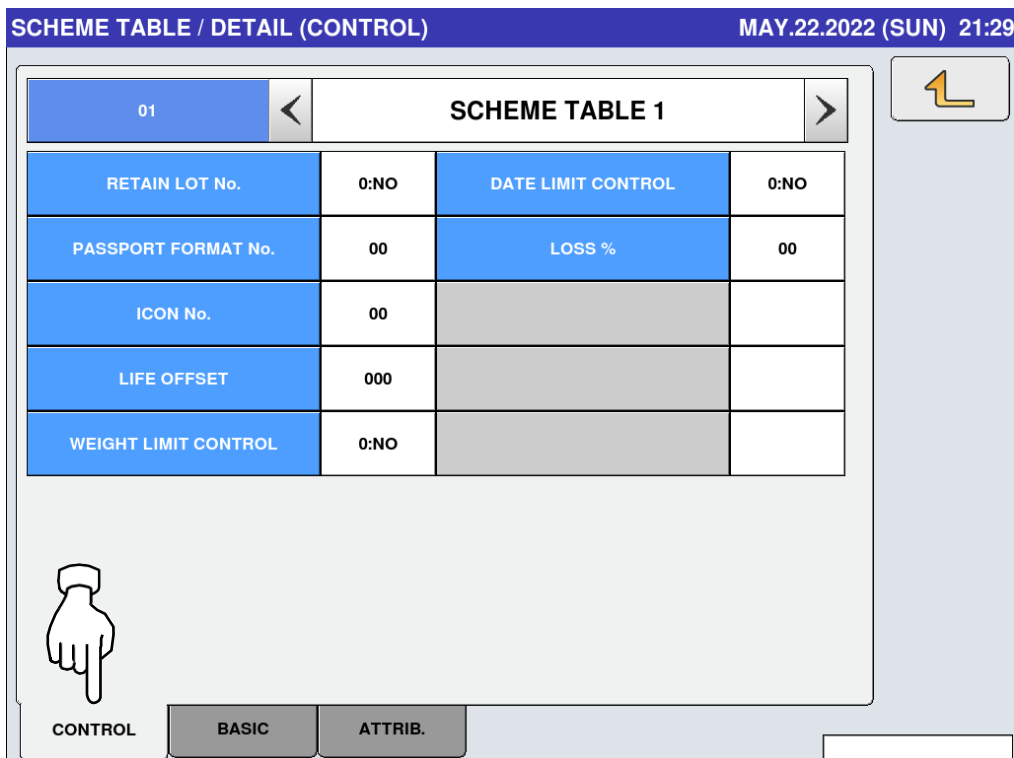
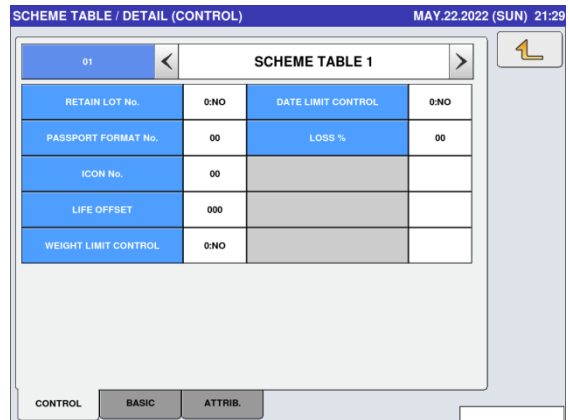

ITEM	DESCRIPTIONS
RETAIN LOT No.	Press this field to select whether or not to use this lot number.
	0: No 1: Yes
PASSPORT FORMAT No.	Enter a numerical value and press this field.
ICON No.	Enter a numerical value and press this field.
LIFE OFFSET	Enter a numerical value and press this field.
WEIGHT LIMIT CONTROL	Press this field to select whether or not to control the weight limit.
	0: No 1: Yes
DATE LIMIT CONTROL	Press this field to select whether or not to control the date limit.
	0: No 1: Yes
LOSS %	Enter a numerical value and press this field



SCHEME TABLE / DETAIL (BASIC) MAY.22.2022 (SUN) 21:30

01
SCHEME TABLE 1

	AI	START	STOP	MAX DIGIT
LOT/CARCASS		00	00	00
GTIN		00	00	00
WEIGHT		00	00	00

PASSPORT LOT START
0

PASSPORT GTIN START
0

CONTROL
BASIC
ATTRIB.

ITEM	DESCRIPTIONS
LOT/CARCASS	Enter a numerical value and press the applicable data field.
GTIN	Enter a numerical value and press the applicable data field.
WEIGHT	Enter a numerical value and press the applicable data field.
PASSPORT LOT START	Enter a numerical value and press the data field.
PASSPORT GTIN START	Enter a numerical value and press this data field.



SCHEME TABLE / DETAIL (ATTRIB.) MAY.22.2022 (SUN) 21:30 1/4

01 < SCHEME TABLE 1 >

TITLE TEXT	START	STOP	AI	VARIABLE
	00	00		0:NO
	00	00		0:NO
	00	00		0:NO
	00	00		0:NO

CONTROL BASIC ATTRIB. DELETE

9. Upon completion of the table data registration, press the Return button.

10. The edited data has been registered.

SCHEME TABLE / DETAIL (CONTROL) MAY.22.2022 (SUN) 21:29

01 < SCHEME TABLE 1 >

RETAIN LOT No.	0:NO	DATE LIMIT CONTROL	0:NO
PASSPORT FORMAT No.	00	LOSS %	00
ICON No.	00		
LIFE OFFSET	000		
WEIGHT LIMIT CONTROL	0:NO		

CONTROL BASIC ATTRIB.

SCHEME TABLE MAY.22.2022 (SUN) 21:31 1/1

1	SCHEME TABLE 1
2	SCHEME TABLE 2

SEARCH TEXT SEARCH DETAIL DELETE

4.16 GEN TABLE DATA

1. Press the “GEN TABLE” icon on the menu selection screen.

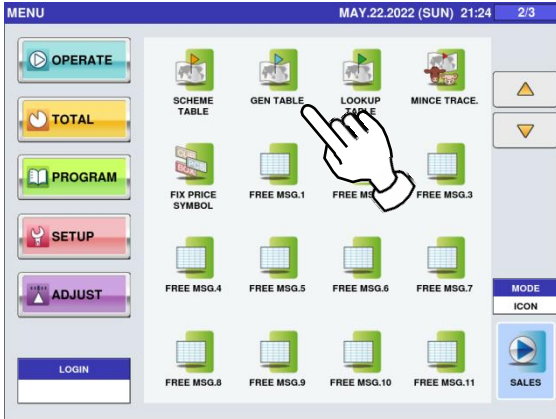

2. The “GEN Table” screen is displayed. Press a desired field for selection.

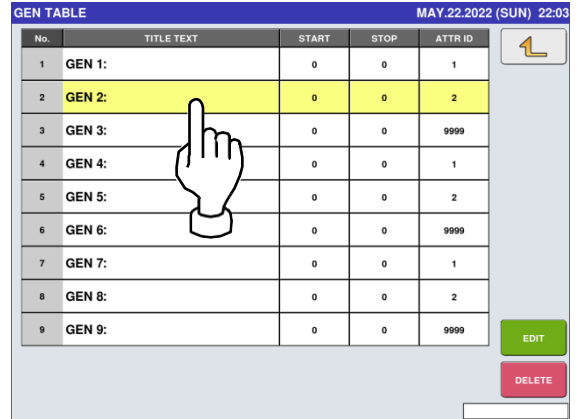

3. Enter a numerical value, press the applicable field, and press the [SET] key.

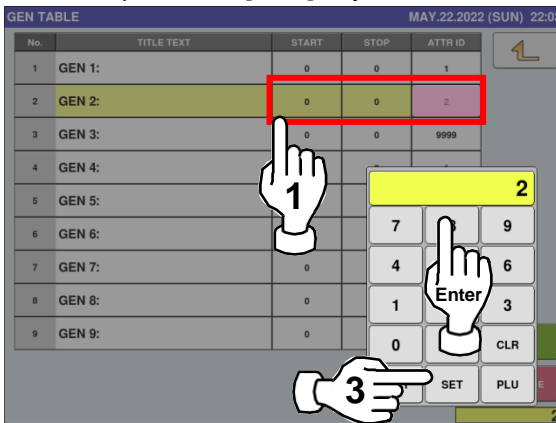

4. To change the text, press the [EDIT] button.

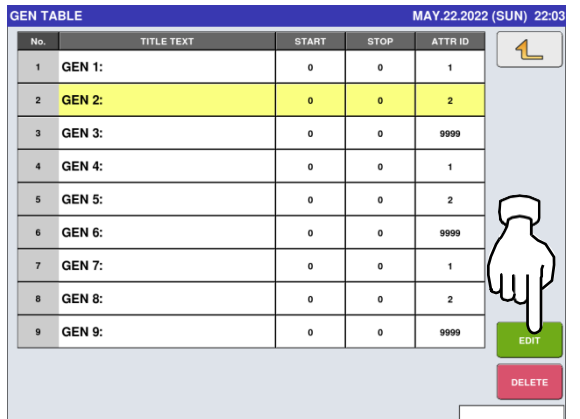

5. The “GEN Table / Title Text Edit” screen is displayed.

Edit text according to the procedure described in Appendix “Text Editing”.

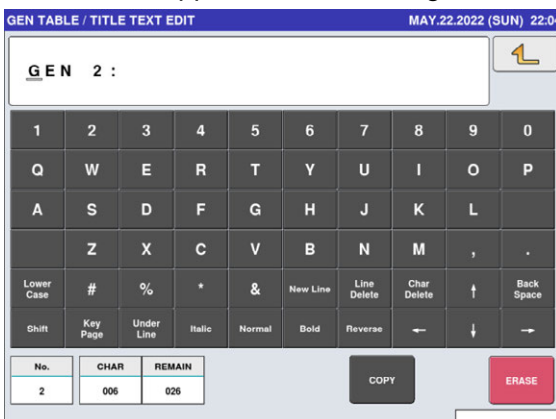

6. Press the Return button to exit the edit mode.



7. The confirmation screen is displayed.
To confirm changes, press [SAVE].
To undo changes, press [CANCEL].

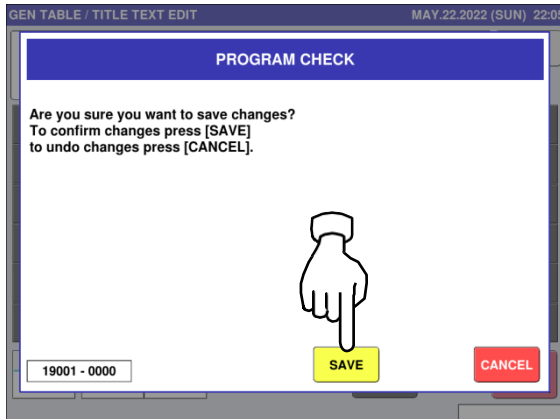

8. The edited data has been registered.

GEN TABLE					MAY.22.2022 (SUN) 22:05	
No.	TITLE TEXT	START	STOP	ATTR ID		
1	GEN 1:	0	0	1		
2	GEN TABLE 2:	0	0	2		
3	GEN 3:	0	0	9999		
4	GEN 4:	0	0	1		
5	GEN 5:	0	0	2		
6	GEN 6:	0	0	9999		
7	GEN 7:	0	0	1		
8	GEN 8:	0	0	2		
9	GEN 9:	0	0	9999		

EDIT
DELETE

4.17 LOOKUP TABLE DATA

1. Press the "LOOKUP TABLE" icon on the menu selection screen.

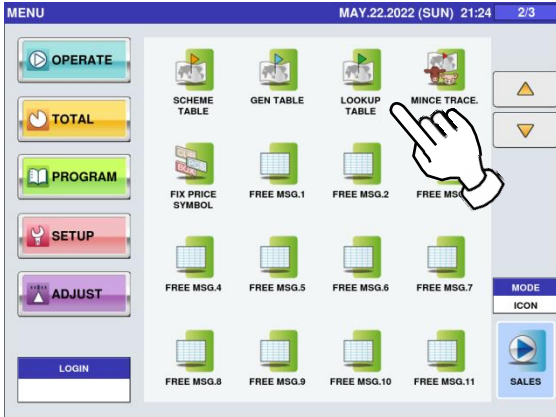

- 2-1 The "Lookup Table" screen is displayed. To create the first table, press the [NEW] button.

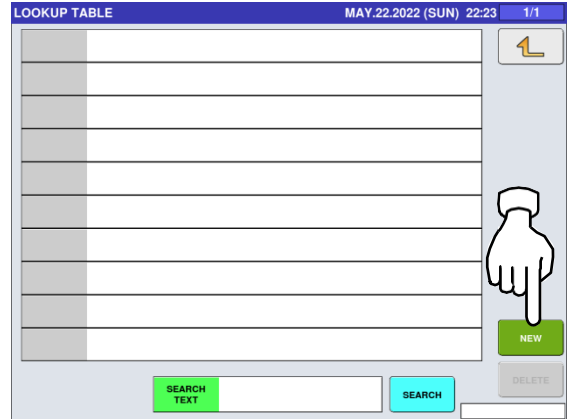

- 2-2 To call up desired data, press the Input field at the bottom right of the screen to display the keypad. Then, enter a numerical value and press the [PLU] key on the keypad.

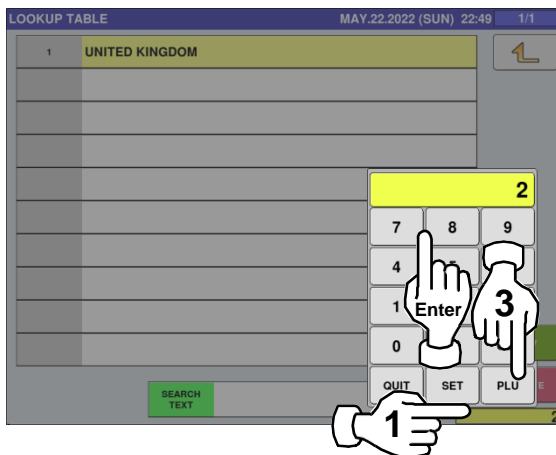

- 2-3 To change existing data, press a desired field for selection and then the [DETAIL] button.



In this case, go to Step 4.

3. If a non-registered item has been called, the confirmation screen is displayed. Press [EXEC] to continue, or [STOP] to go back.

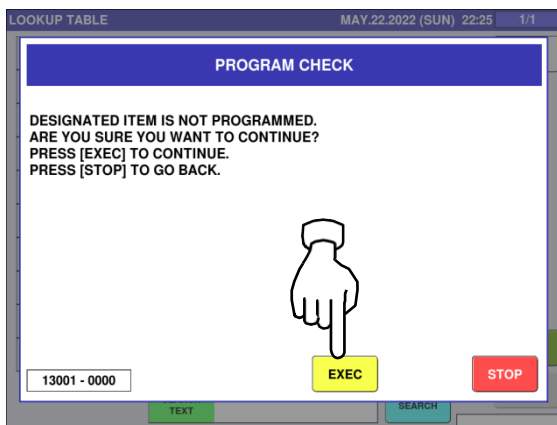

4. The "Lookup Table / Name Edit" screen is displayed. Edit text according to the procedure described in Appendix "Text Editing".

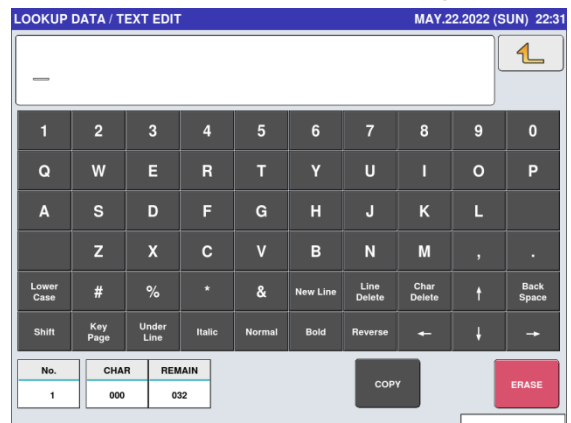

5. Press the Return button to finish the editing.

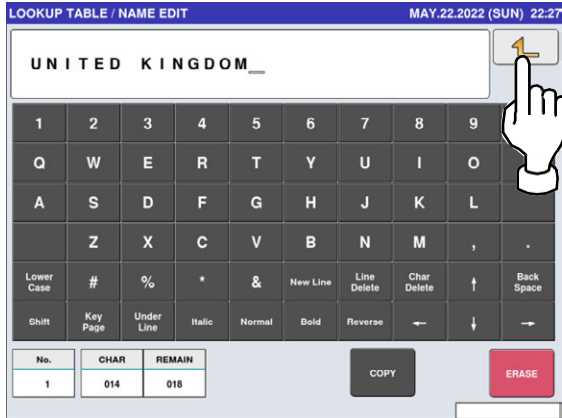

6. The confirmation screen is displayed. To confirm changes, press [SAVE]. To undo changes, press [CANCEL].

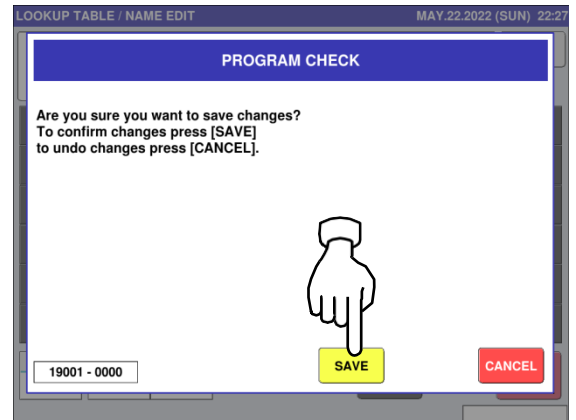

7. The edited text has been registered.

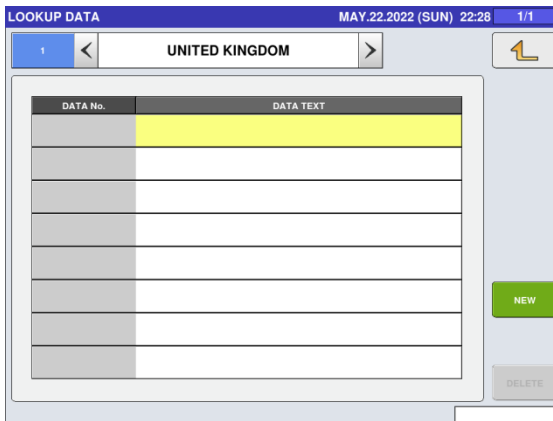

- 8-1. To create the first data, press the [NEW] button.

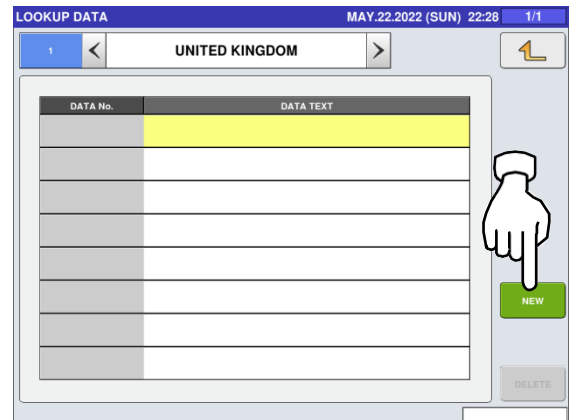

- 8-2. To call up desired data, press the Input field at the bottom right of the screen to display the keypad. Then, enter a numerical value and press the [PLU] key on the keypad.

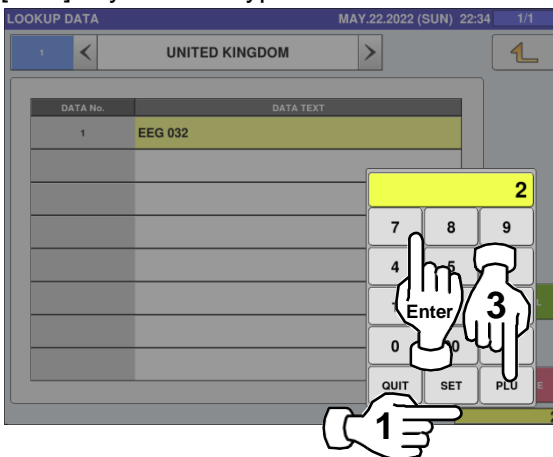

- 8-3. To change existing data, press a desired field for selection and then the [DETAIL] button.

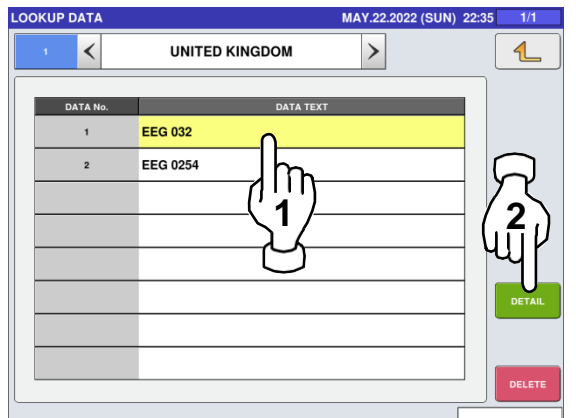

9. The Lookup Data / Text Edit screen is displayed.
Edit text according to the procedure described in Appendix "Text Editing".

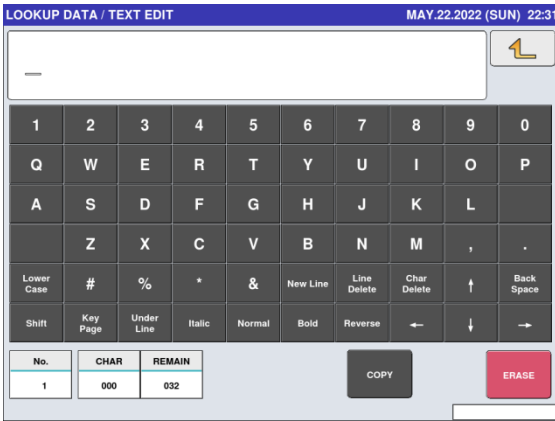

10. Press the Return button to finish the editing.

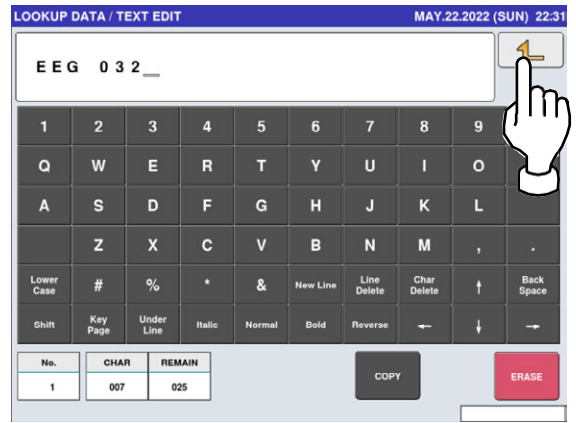

11. The confirmation screen is displayed.
To confirm changes, press [SAVE].
To undo changes, press [CANCEL].

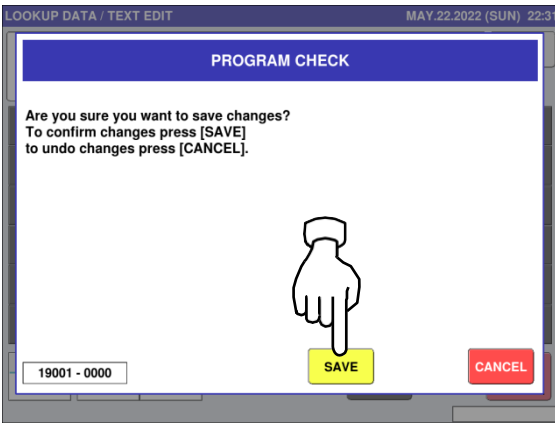

12. The edited data has been registered.

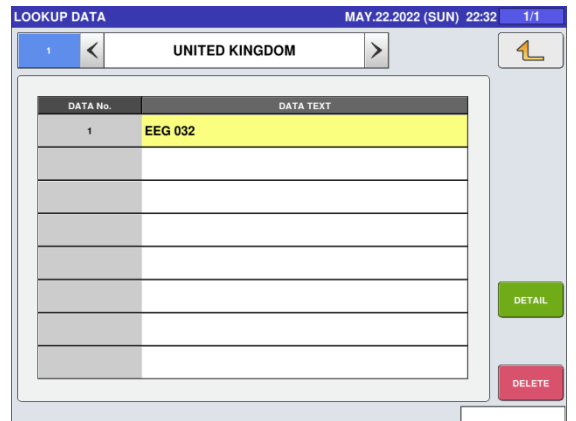

4.18 MINCE TRACEABILITY DATA

1. Press the "MINCE TRACE." icon on the menu selection screen.

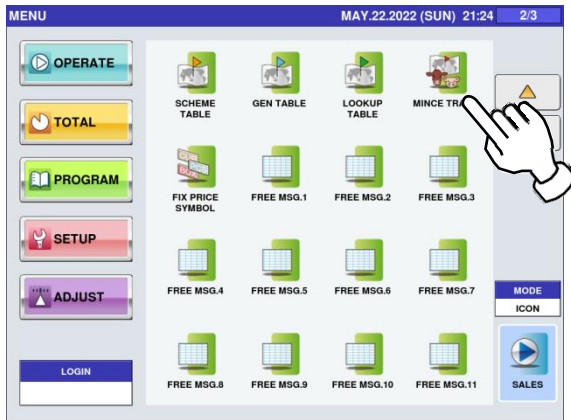

2. The "Mince Traceability" screen is displayed. Press a desired field for selection.

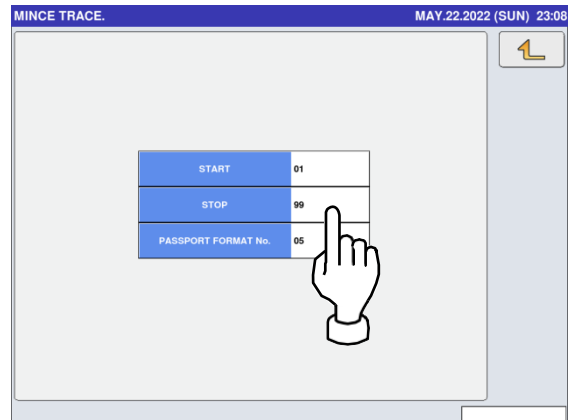

3. The keypad is displayed. Enter a desired numerical value and press the [SET] key.

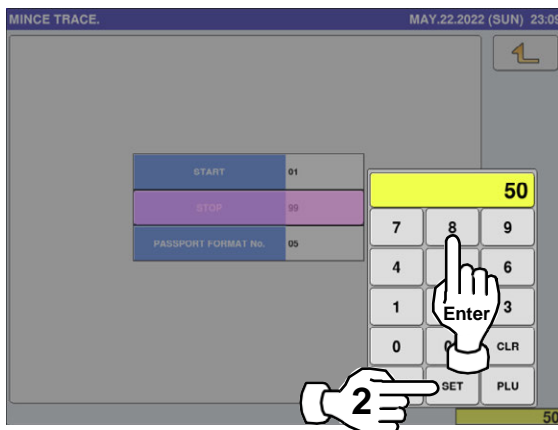

4. Press the Return button to complete the procedure.

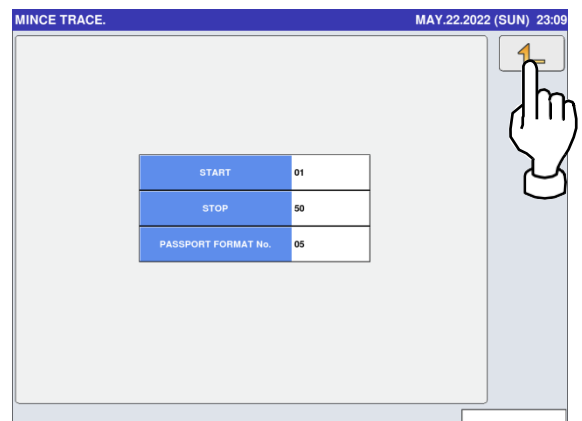

4.19 FIXED PRICE SYMBOLS

1. Press the "FIX PRICE SYMBOL" icon on the menu selection screen.



2. The "Fix Price Symbol" screen is displayed.



3. Press the Input field at the bottom right of the screen to display the keypad.

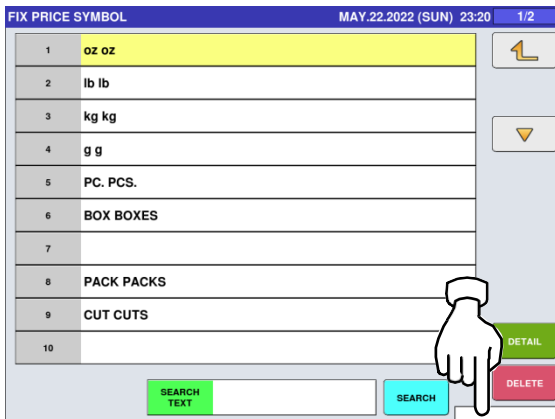

4. Enter a desired table number and press the [PLU] key on the keypad.

EXAMPLE Symbol No.7

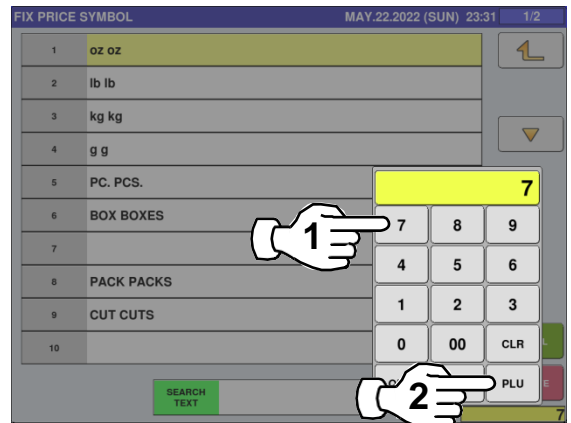

5. The "Fix Price Symbol / Edit" screen is displayed.

Edit text according to the procedure described in Appendix "Text Editing".

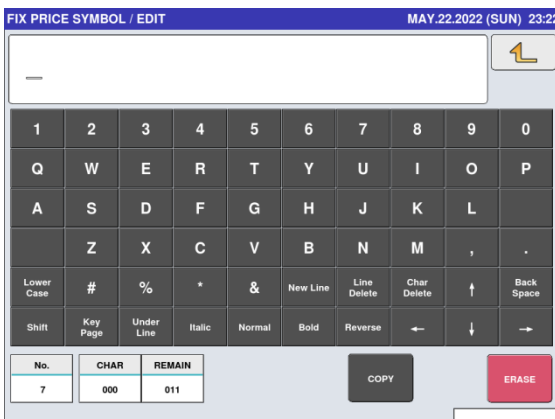

6. Press the Return button to finish the editing.



7. The confirmation screen is displayed.
To confirm changes, press [SAVE].
To undo changes, press [CANCEL].

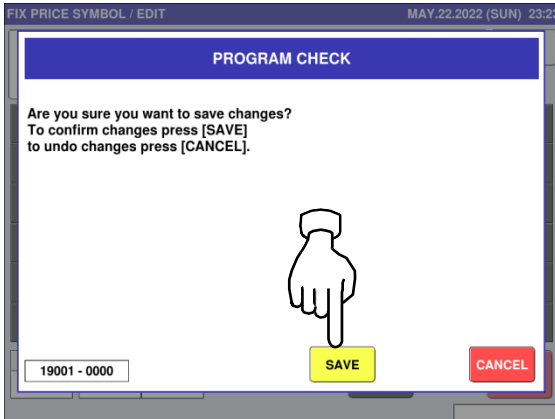

8. The edited text has been registered.

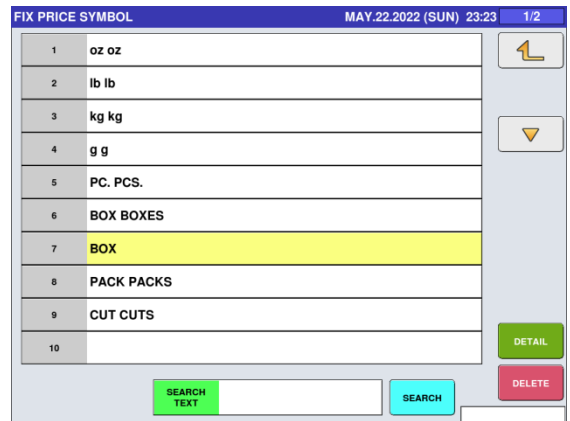

4.20 FREE MESSAGE DATA

1. Press the "FREE MSG." icon on the menu selection screen.

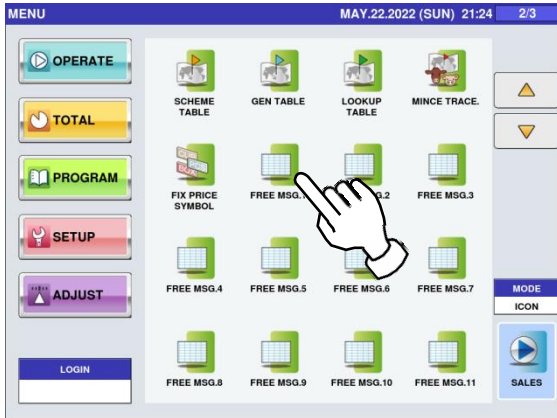

- 2-1 The "Free Message" screen is displayed. To create the first message, press the [NEW] button.

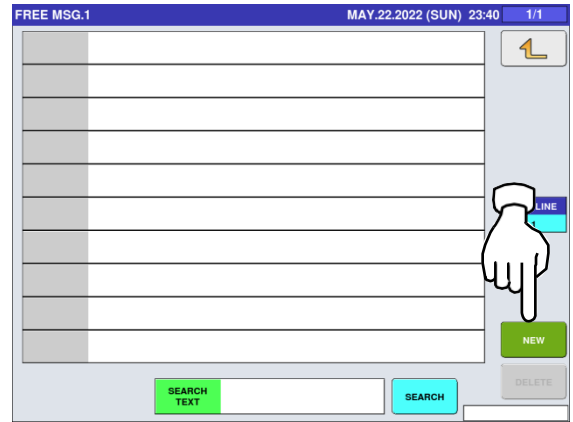

- 2-2 To call up desired data, press the Input field at the bottom right of the screen to display the keypad. Then, enter a numerical value and press the [PLU] key on the keypad.

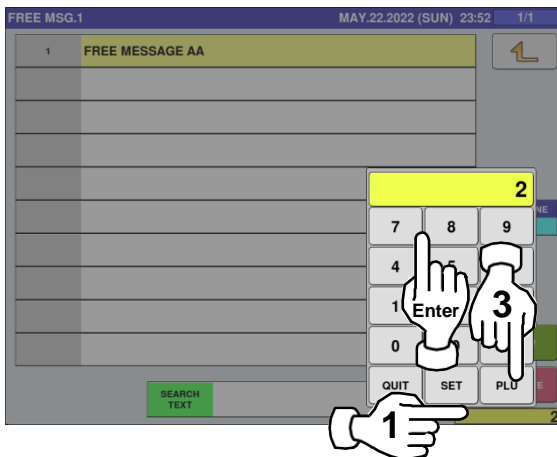

- 2-3 To change existing data, press a desired field for selection and then the [DETAIL] button.

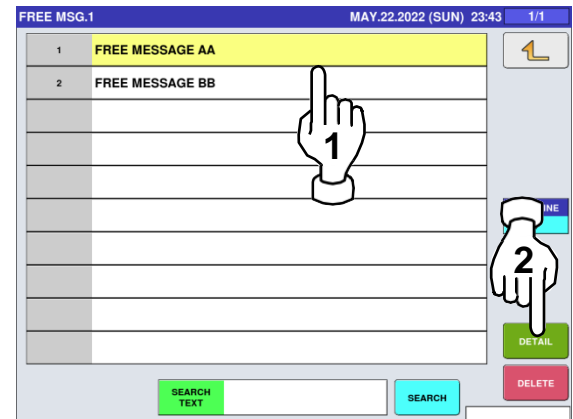

In this case, go to Step 4.

3. If a non-registered item has been called, the confirmation screen is displayed. Press [EXEC] to continue, or [STOP] to go back.

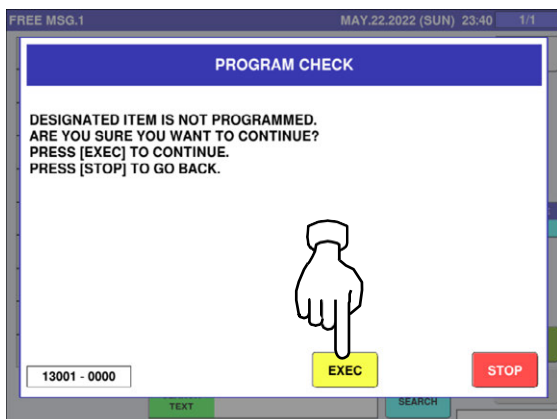

4. The "Free Message Edit" screen is displayed. Edit text according to the procedure described in Appendix "Text Editing".

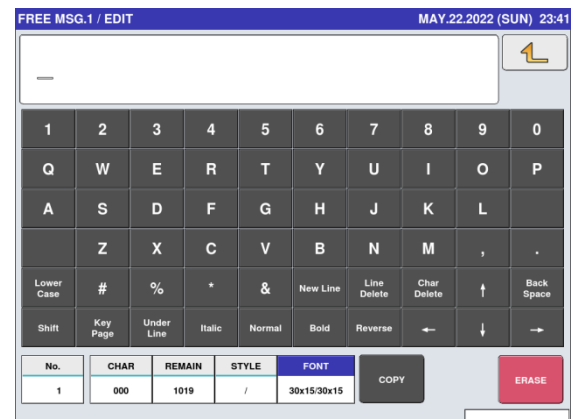

5. Press the Return button to finish the editing.



6. The confirmation screen is displayed.
To confirm changes, press [SAVE].
To undo changes, press [CANCEL].

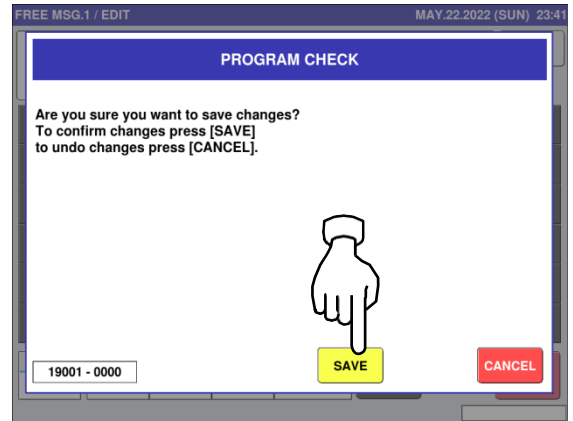

7. The edited data has been registered.



4.21 CHECK LABEL DATA

1. Press the "CHECK LABEL" icon on the menu selection screen.

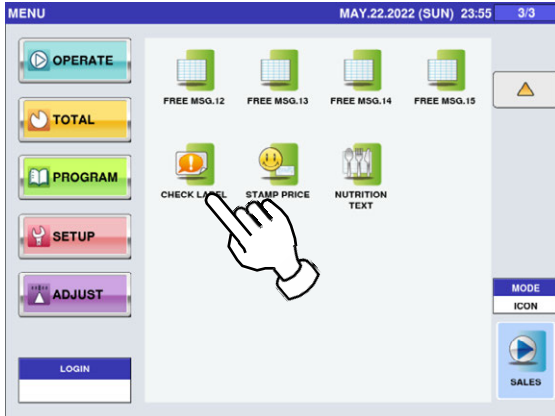

2. The "Check Label" screen is displayed. Press a desired field.

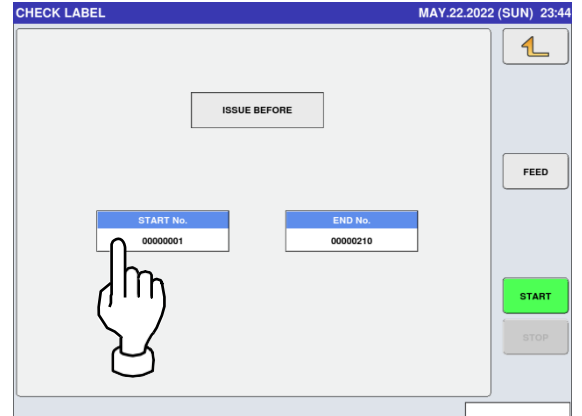

3. Enter the start number and the end number via the keypad, and press the [SET] key.

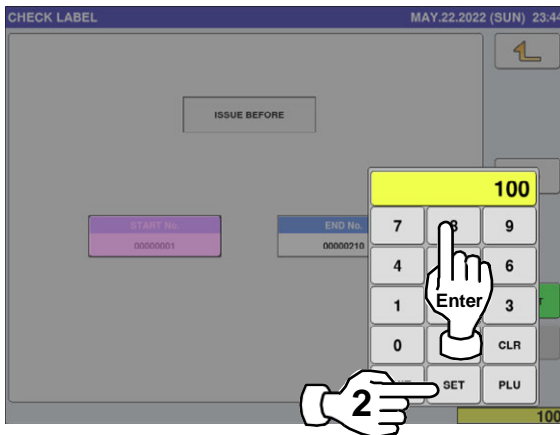

4. Press the [STRAT] button to print a label.

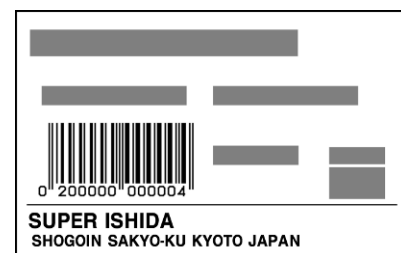
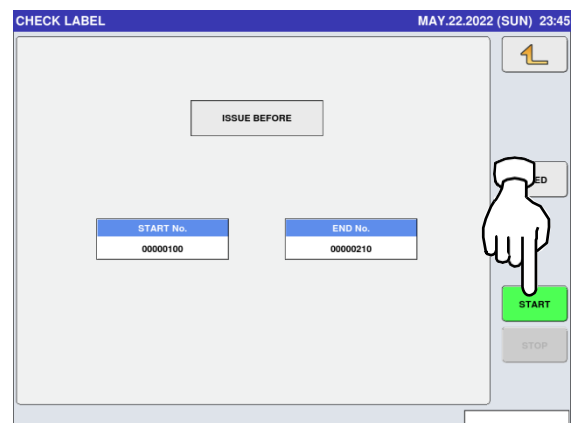

4.22 STAMP PRICE DATA

1. Press the "STAMP PRICE" icon on the menu selection screen.

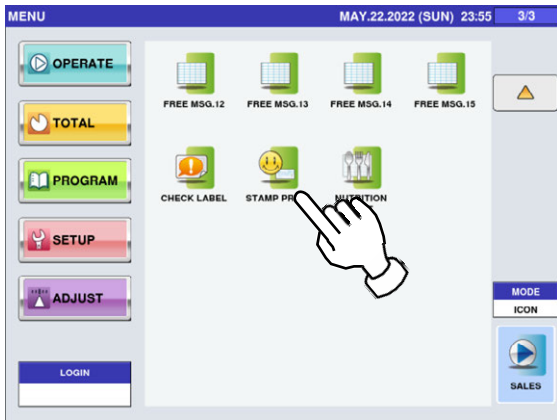

2. The "Stamp Price" screen is displayed. Press a desired field for selection.

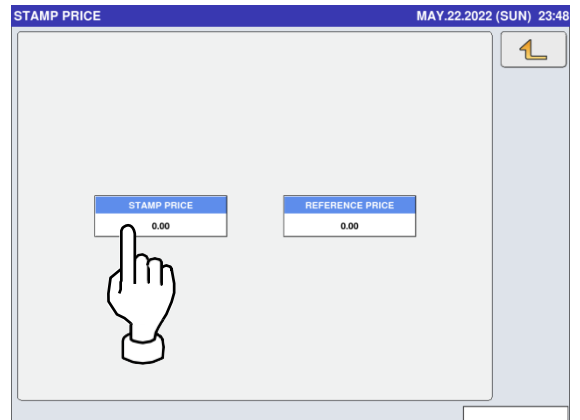

3. Enter the stamp price and the reference price via the keypad, and press the [SET] key.

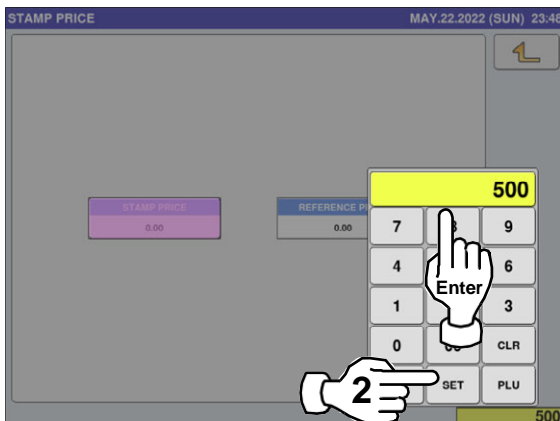

4.23 NUTRITION TEXT DATA

1. Press the "NUTRITION TEXT" icon on the menu selection screen.

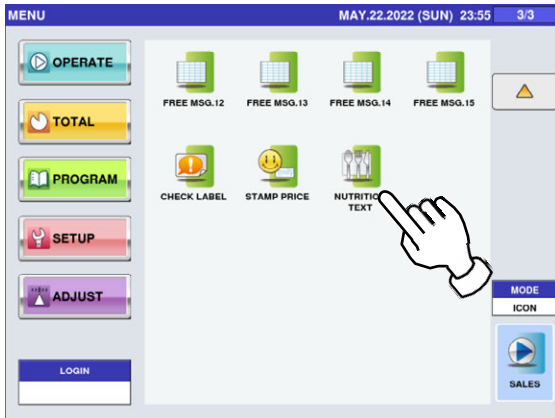

- 2-1 The "Nutrition Text" screen is displayed. To create the first text, press the [NEW] button.

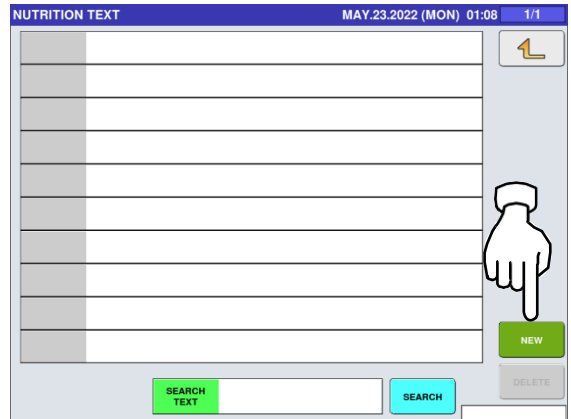

- 2-2 To call up desired data, press the Input field at the bottom right of the screen to display the keypad. Then, enter a numerical value and press the [PLU] key on the keypad.

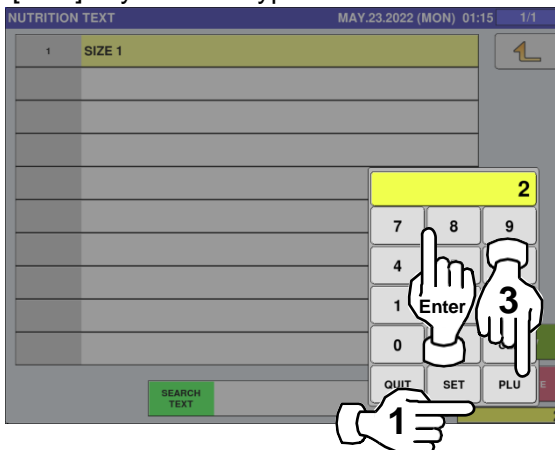

- 2-3 To change existing data, press a desired field for selection and then the [DETAIL] button.

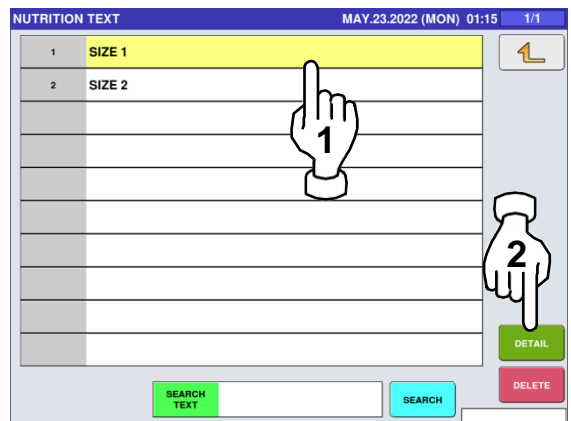

In this case, go to Step 4.

3. If a non-registered item has been called, the confirmation screen is displayed. Press [EXEC] to continue, or [STOP] to go back.

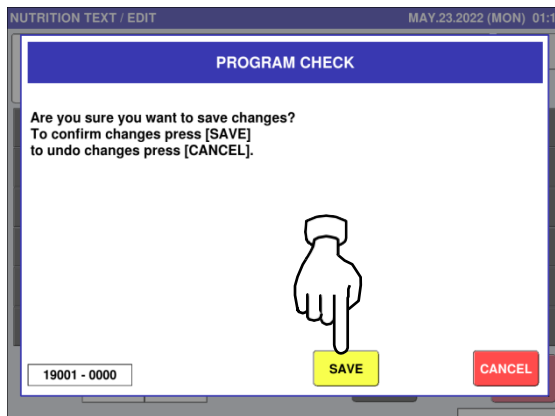

4. The "Nutrition Text / Detail" screen is displayed. To create a new text, press a desired field.

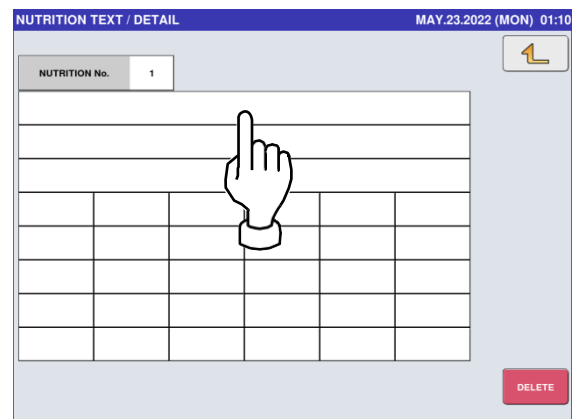

- The "Nutrition Text / Edit" screen is displayed.
Edit text according to the procedure described in Appendix "Text Editing".

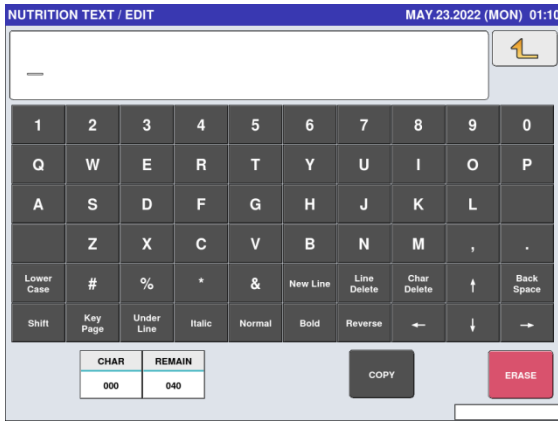

- Press the Return button to finish the editing.

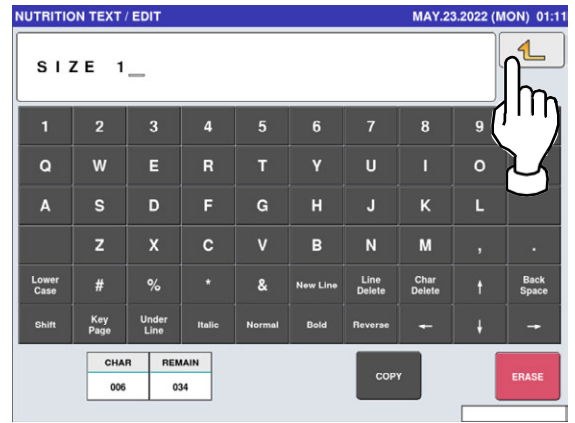

- The confirmation screen is displayed. To confirm changes, press [SAVE]. To undo changes, press [CANCEL].

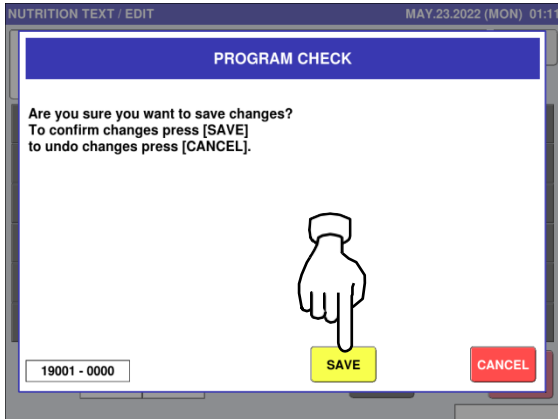

- The edited data has been registered.

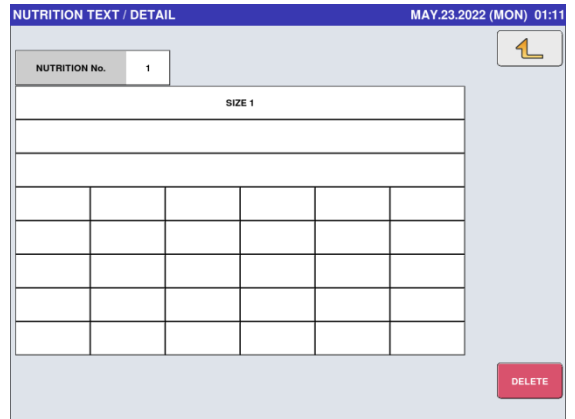

4.24 NUTRITION DATA

1. Press the "NUTRITION" icon on the menu selection screen.



- 2-1 The "Nutrition" screen is displayed. To create the first text, press the [NEW] button.

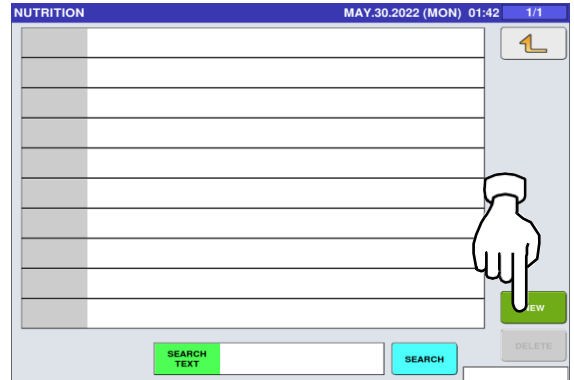

- 2-2 To call up desired data, press the Input field at the bottom right of the screen to display the keypad. Then, enter a numerical value and press the [PLU] key on the keypad.

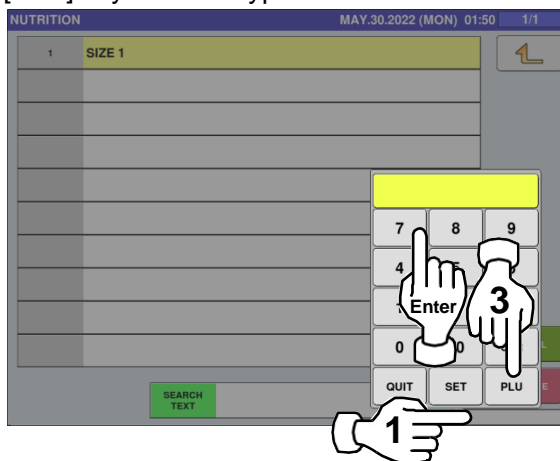

- 2-3 To change existing data, press a desired field for selection and then the [DETAIL] button.

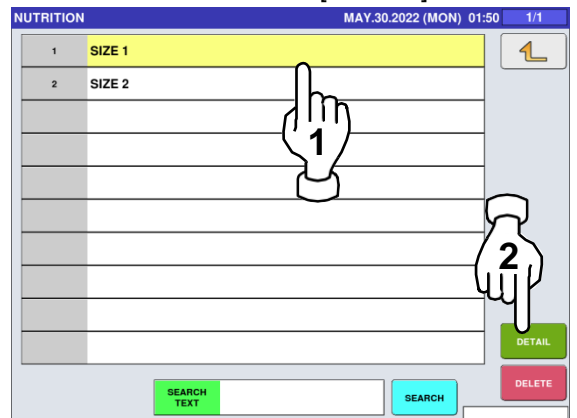

In this case, go to Step 4.

3. If a non-registered item has been called, the confirmation screen is displayed. Press [EXEC] to continue, or [STOP] to go back.

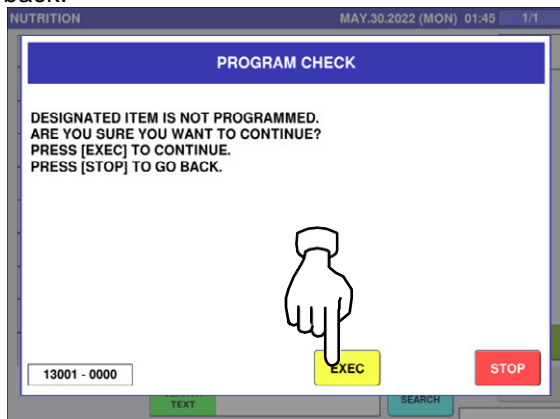

4. The "Nutrition Data / Detail" screen is displayed. To create a new text, press a desired field.

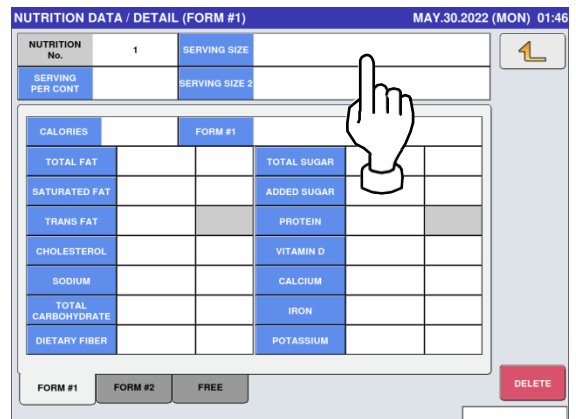

5. The "Nutrition / Edit" screen is displayed.
 Edit text according to the procedure described in Appendix "Text Editing".



6. Press the Return button to finish the editing.

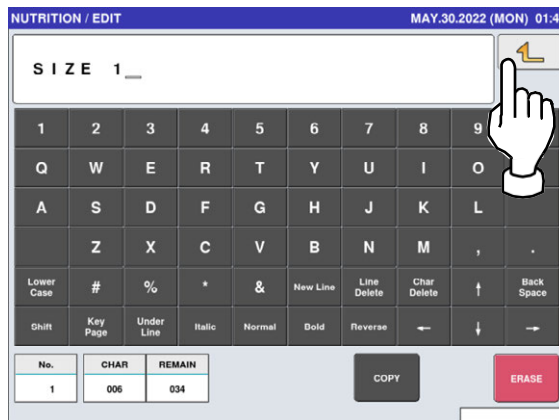

7. The confirmation screen is displayed.
 To confirm changes, press [SAVE].
 To undo changes, press [CANCEL].

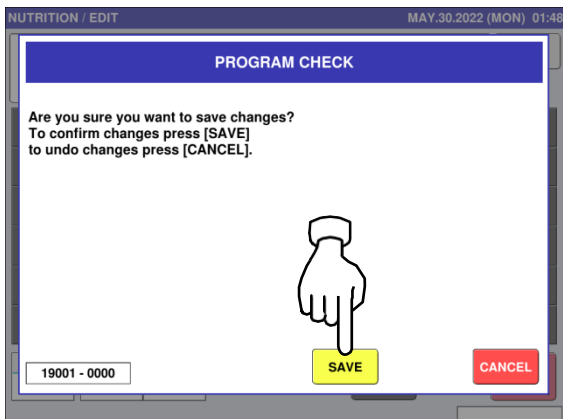

8. The edited data has been registered.

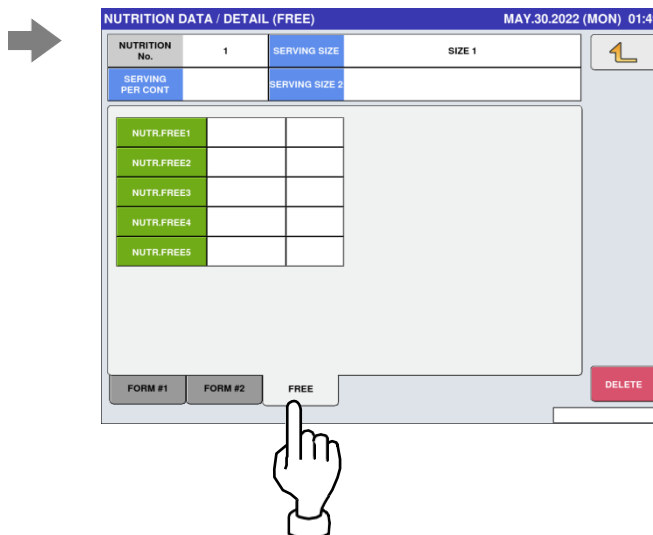
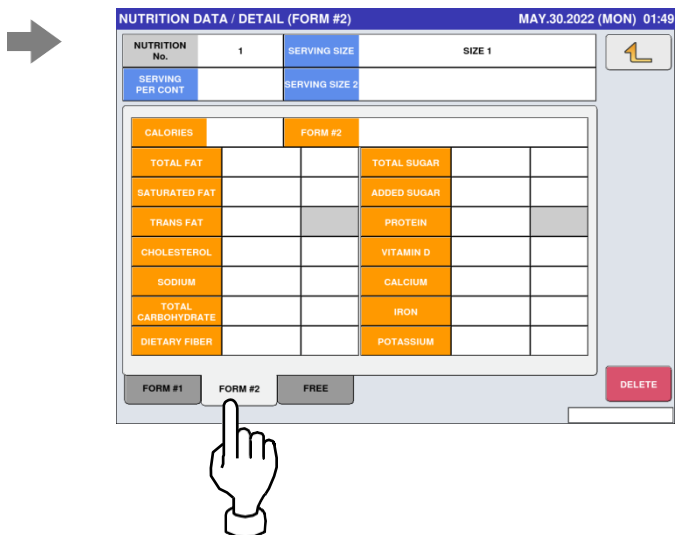
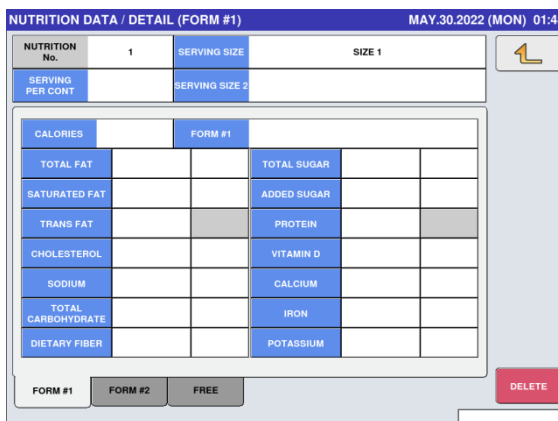

SETUP MODE

5.1 SETUP MODE ENTRY / EXIT

1. Ensure that the initial screen is displayed. Then, press the Return button on the screen to display the "Menu" screen.

Note: The contents of the initial screen may differ depending on the settings on your machine.

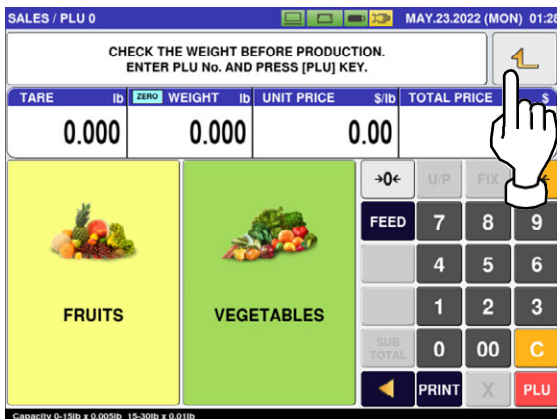

2. The "Menu" screen is displayed. Then, press the [SETUP] button.

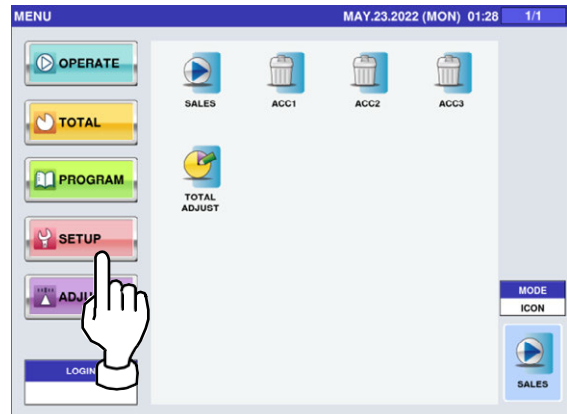

3. The setup menu selection screen is displayed.

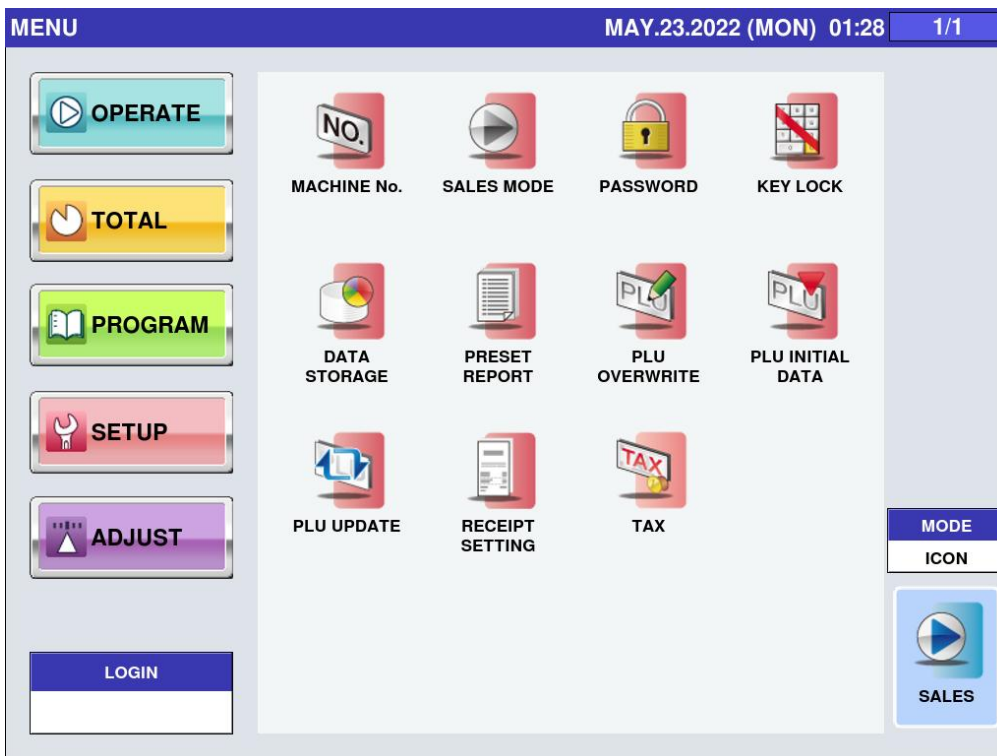

Note: To exit the Setup Mode, press the [SALES] button.

5.2 MACHINE NUMBER / NETWORK NUMBER

1. Press the "MACHINE No." icon on the menu selection screen.

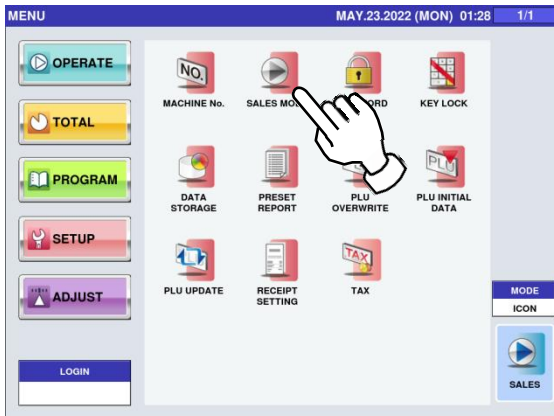

The "Machine No. (Basic)" screen is displayed.

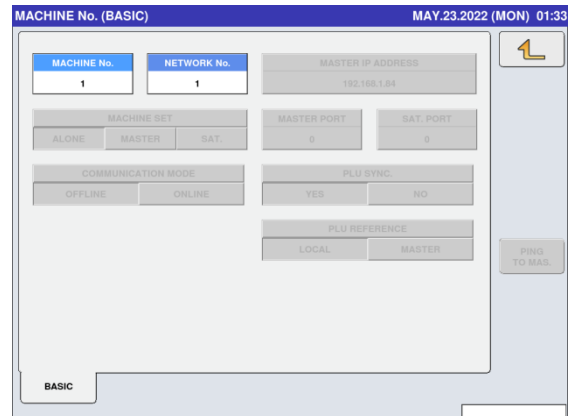

2. Press a desired field for selection
EXAMPLE Network No.9

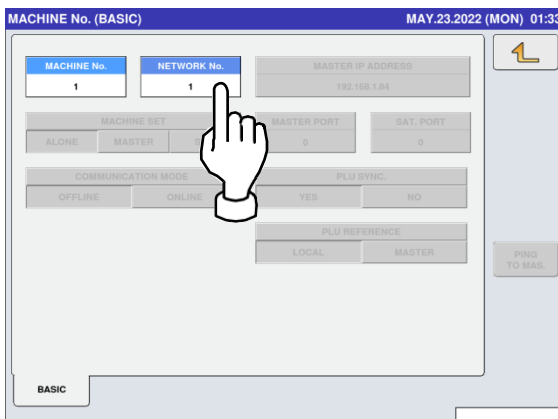

- 3.

Enter a numerical value via the keypad and press the [SET] key.

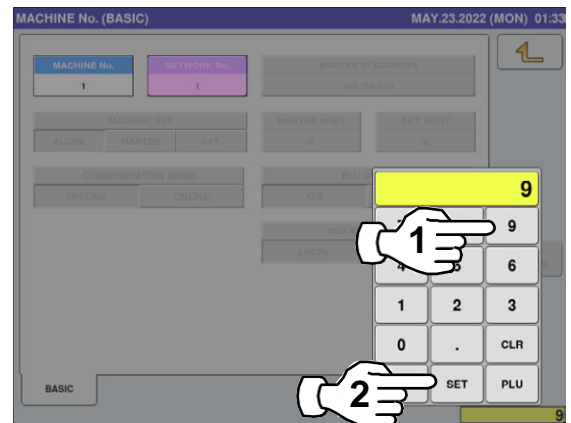

4. Press a desired field for selection
EXAMPLE Network No.9

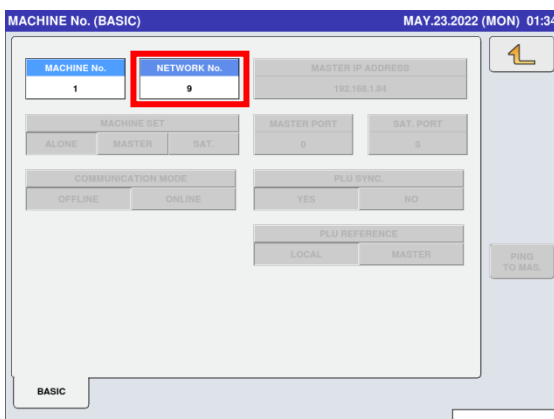

- 5.

The network number has been registered. To finish the editing, press the Return button.



6. The confirmation screen is displayed.
Press [EXEC] to continue, or [STOP] to go back.

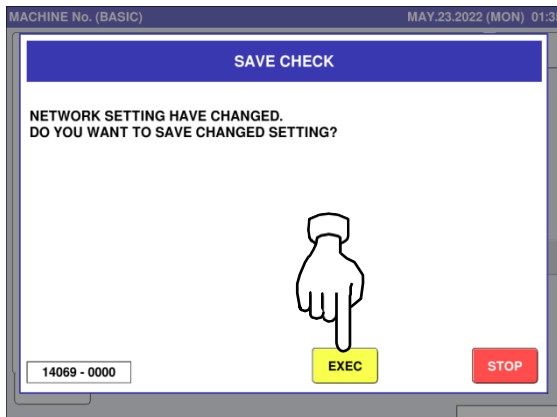

5.3 SALES MODE

1. Press the “SALES MODE” icon on the menu selection screen.

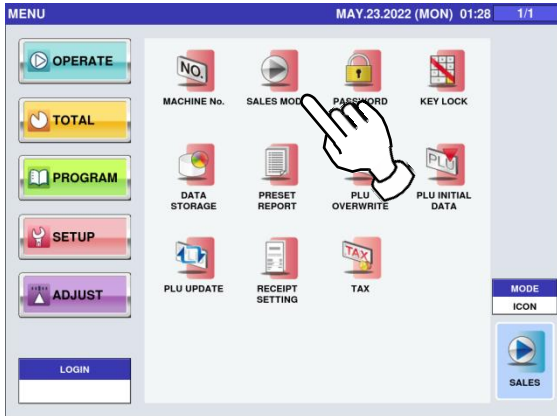

2. The “Sales Mode” screen is displayed. Then, select a desired sales mode by pressing the corresponding button.

EXAMPLE “With Operator”

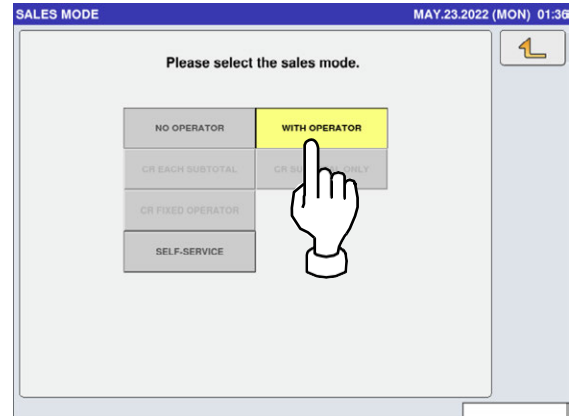

3. Press the Return button to complete the procedure.

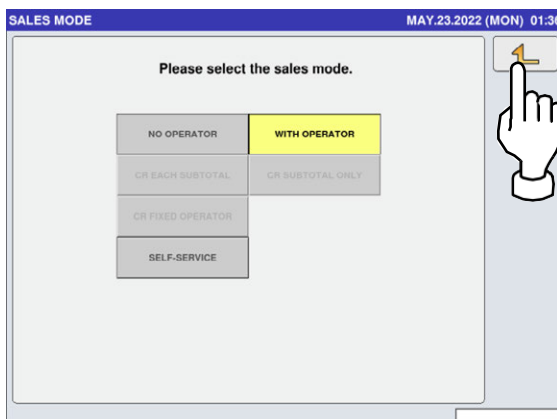

5.4 PASSWORD

1. Press the "PASSWORD" icon on the menu selection screen.

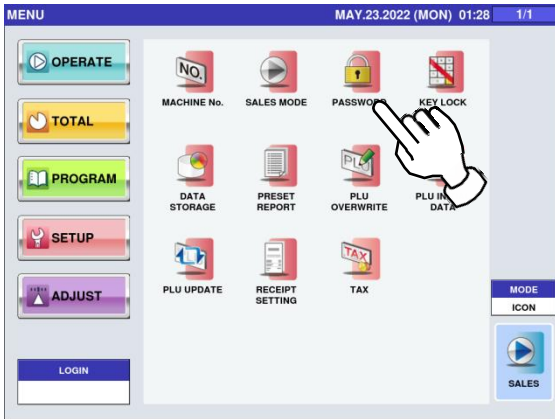

➔ The "Password (Operate)" screen is displayed.

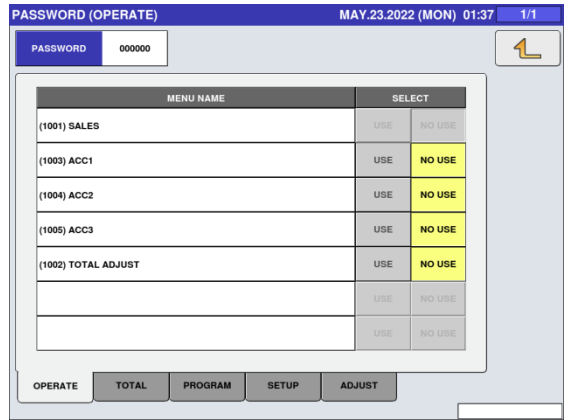

2. Press the "TOTAL" tab to display the "Password (Total)" screen.

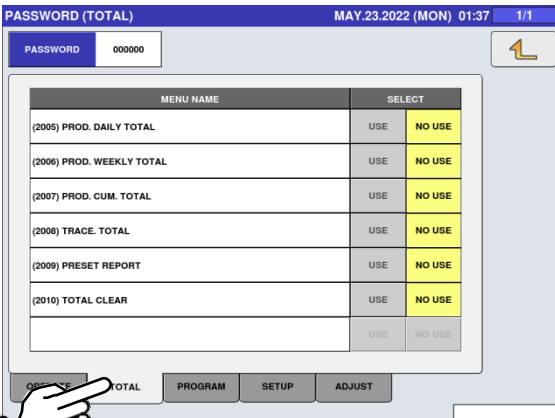

3. Press the "PROGRAM" tab to display the "Password (Program)" screen.

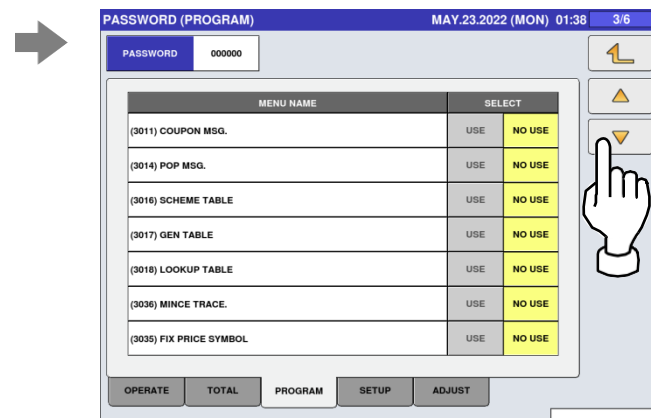
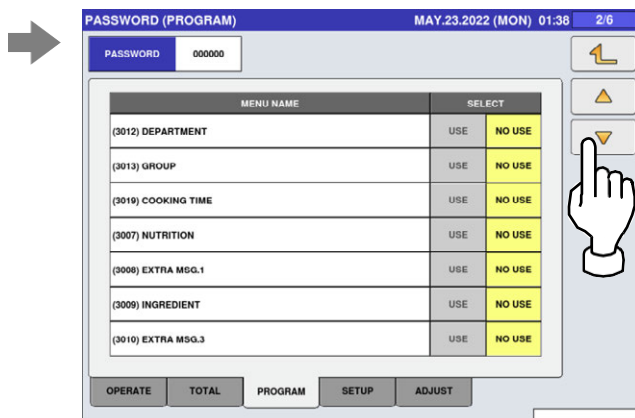
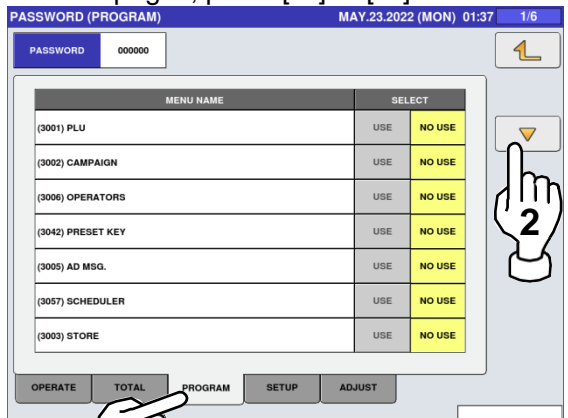

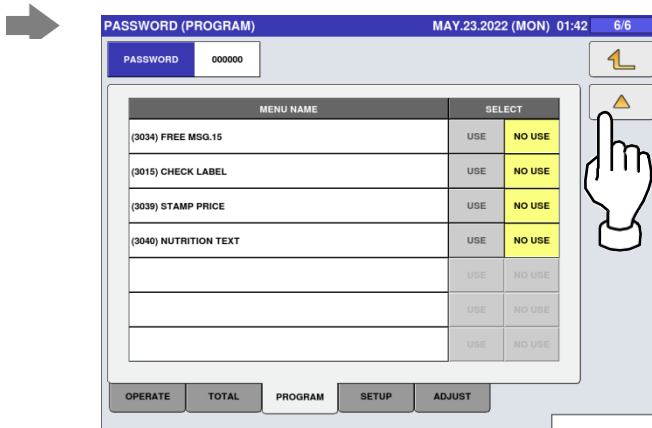
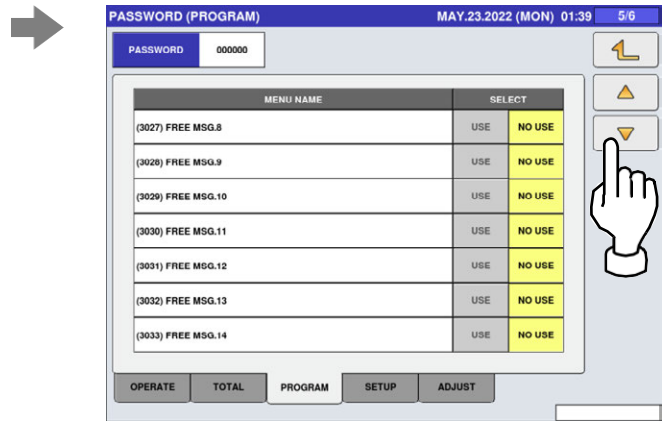
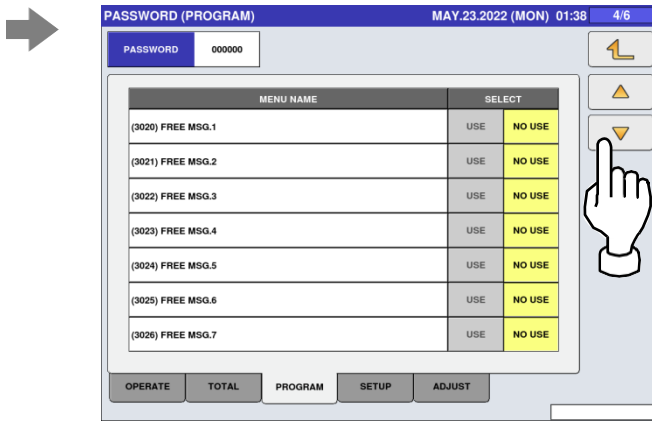

4.

Press the “SETUP” tab to display the “Password (Setup)” screen. To turn pages, press [▼] or [▲].

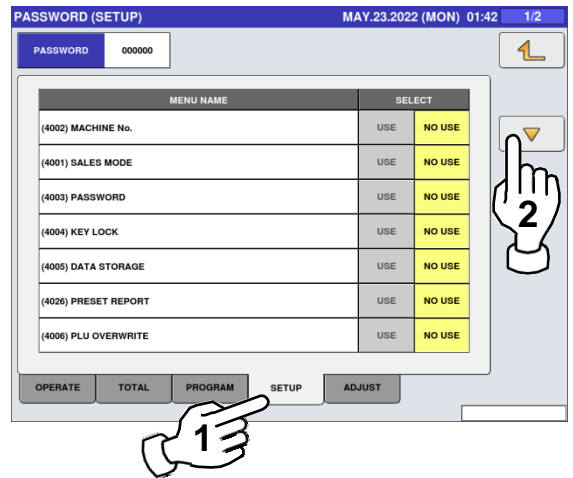

5.

Press the “ADJUST” tab to display the “Password (Adjust)” screen.

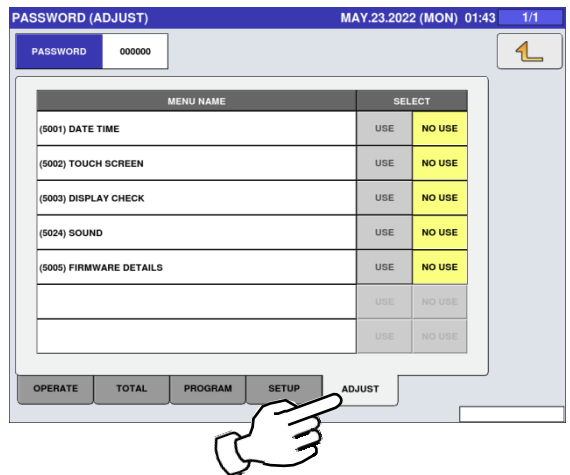
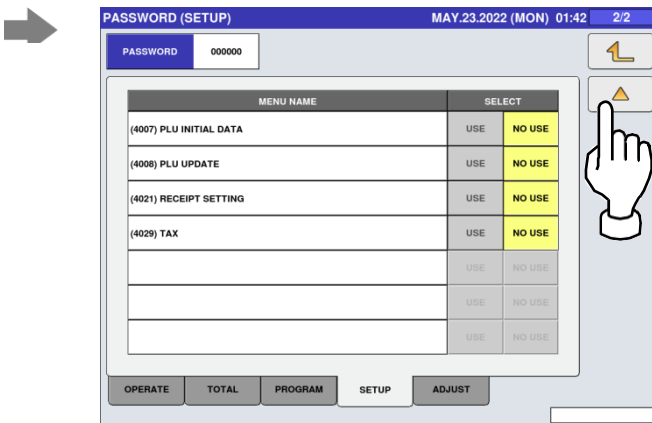

6. Press the “PASSWORD” field to display the keypad.
Enter a 6-digit password and press [SET] key on the keypad.

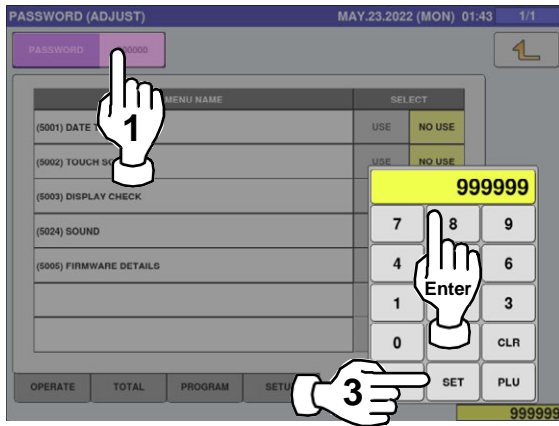

7. Select a desired mode by pressing the corresponding tab, and press any selection buttons to set whether or not to prompt the operator for the password for each menu.

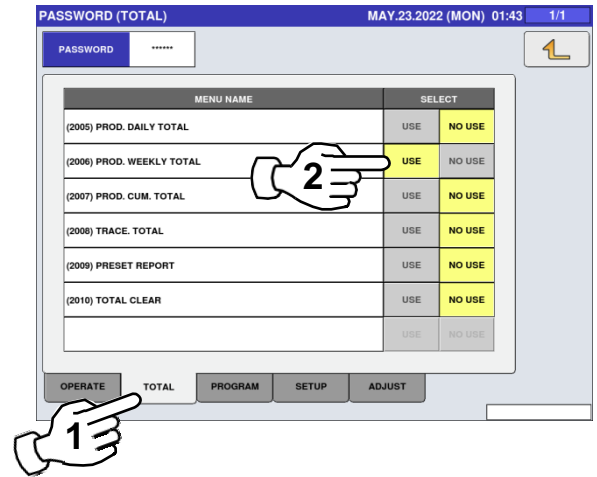

8. Press the Return button to complete the procedure.

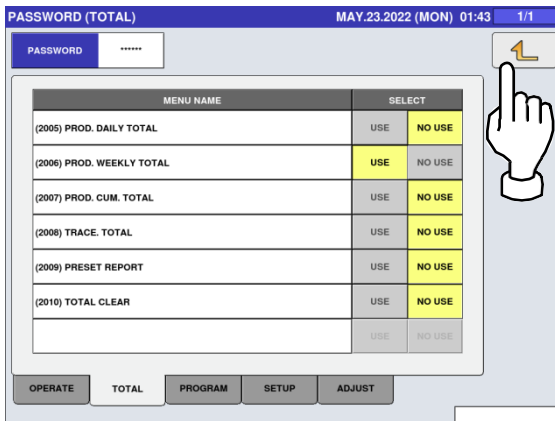

5.5 KEY LOCK

1. Press the "KEY LOCK" icon on the menu selection screen.

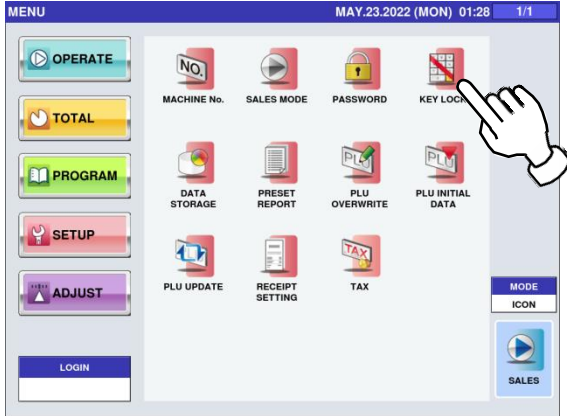

➔ The "Key Lock (Display Key)" screen is displayed.

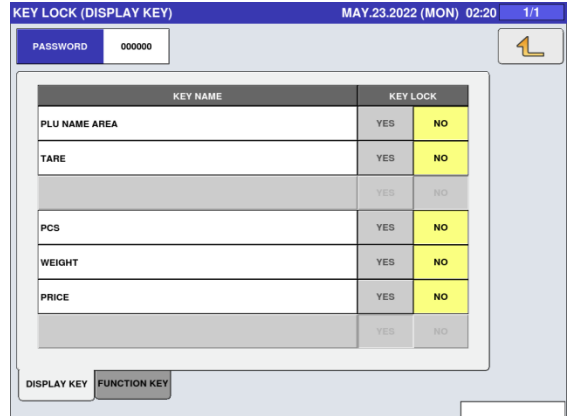

2. Press the "FUNCTION KEY" tab to display the "Key Lock (Function Key)" screen. To turn pages, press [▼] or [▲].

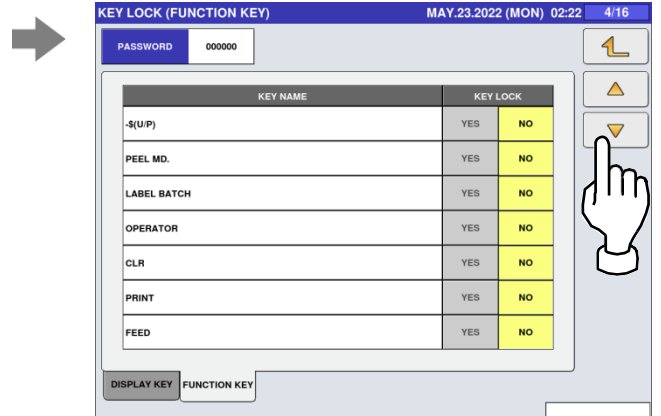
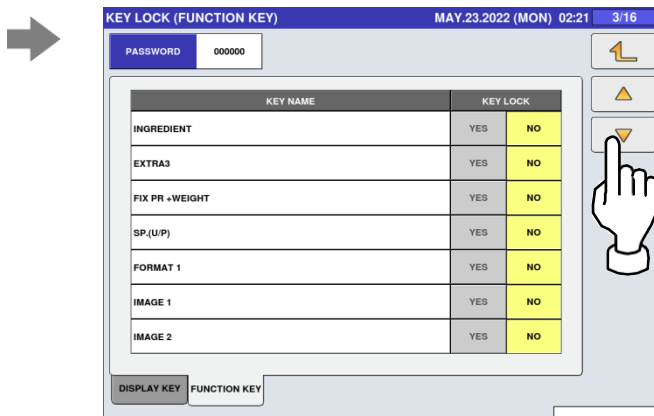
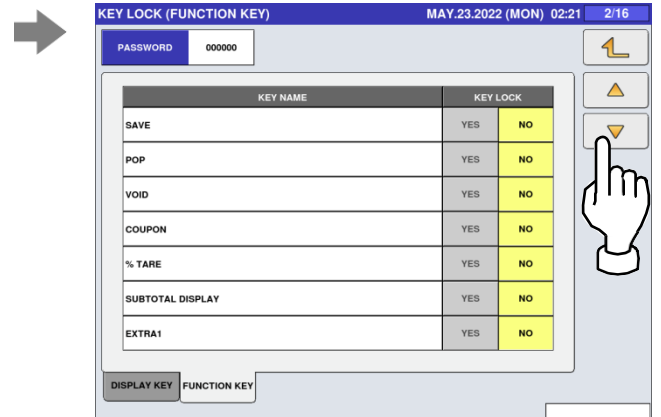
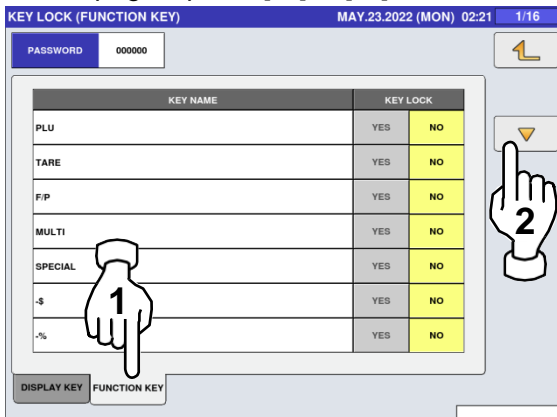

The following tables represent the data shown in each of the eight screenshots:

Screenshot 5/16:

KEY NAME	KEY LOCK
UP	YES NO
P DATE	YES NO
S DATE	YES NO
BAR Y/N	YES NO
TOTAL DISPLAY	YES NO
CALC.	YES NO
IMAGE 3	YES NO

Screenshot 6/16:

KEY NAME	KEY LOCK
FREE MSG.1	YES NO
FREE MSG.2	YES NO
FREE MSG.3	YES NO
FREE MSG.4	YES NO
FREE MSG.5	YES NO
FREE MSG.6	YES NO
FREE MSG.7	YES NO

Screenshot 7/16:

KEY NAME	KEY LOCK
FREE MSG.8	YES NO
FREE MSG.9	YES NO
FREE MSG.10	YES NO
FREE MSG.11	YES NO
FREE MSG.12	YES NO
FREE MSG.13	YES NO
FREE MSG.14	YES NO

Screenshot 8/16:

KEY NAME	KEY LOCK
FREE MSG.15	YES NO
TARGET	YES NO
-(U/P)	YES NO
FORMAT 2	YES NO
2nd LABEL ONLY PRINT	YES NO
CASSETTE	YES NO
SH FLAG	YES NO

Screenshot 9/16:

KEY NAME	KEY LOCK
FIX UPR	YES NO
ERROR LOG	YES NO
AUTO PRN	YES NO
PLU No.	YES NO
1/2	YES NO
TOTAL ADD	YES NO
TRACE.	YES NO

Screenshot 10/16:

KEY NAME	KEY LOCK
PASSPORT	YES NO
CSIS ONLINE	YES NO
ManWT oz	YES NO
DISTRIB.	YES NO
MINCE	YES NO
00	YES NO
.	YES NO

Screenshot 11/16:

KEY NAME	KEY LOCK
MEMORY	YES NO
AUTO PLU	YES NO
0	YES NO
1	YES NO
2	YES NO
3	YES NO
4	YES NO

Screenshot 12/16:

KEY NAME	KEY LOCK
5	YES NO
6	YES NO
7	YES NO
8	YES NO
9	YES NO
PLU CALL	YES NO
LOG IN/OUT	YES NO

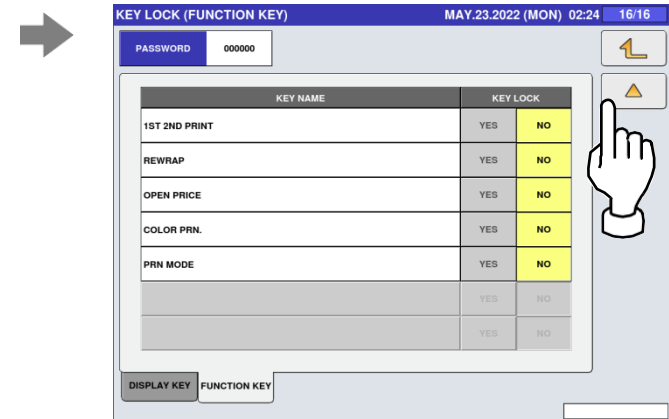
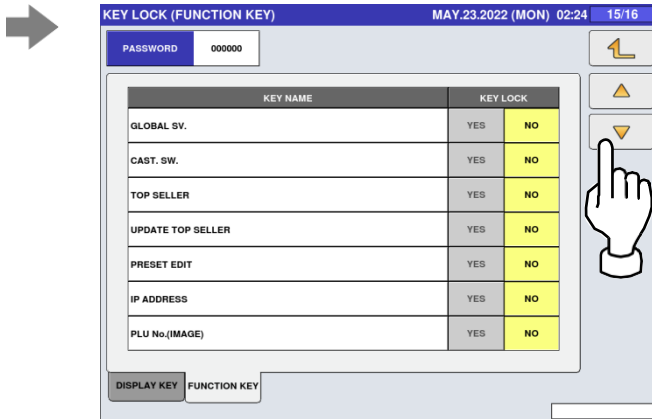
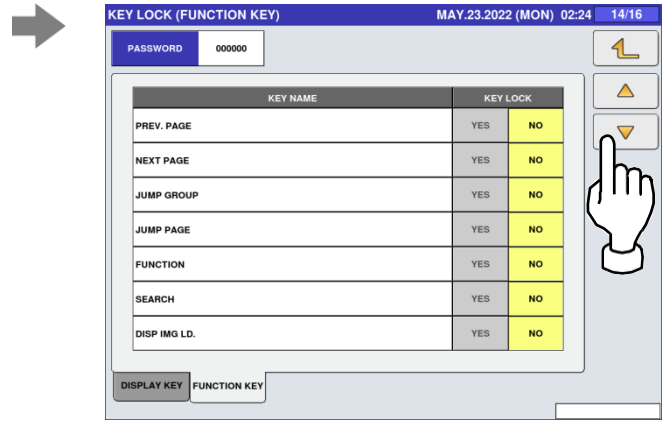
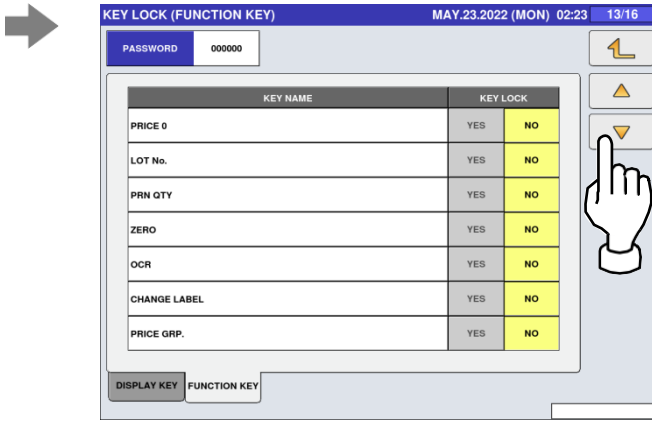

3. Press the “PASSWORD” field to display the keypad. Then, enter a 6-digit password and press the [SET] key on the keypad.

4. Select a desired key category by pressing the corresponding tab, and press any selection buttons to lock or unlock the key.

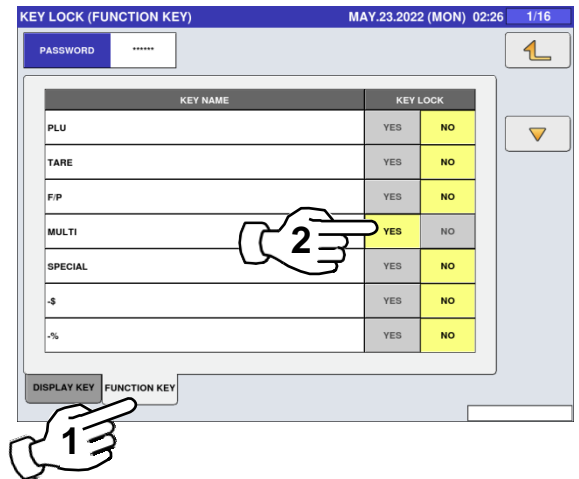
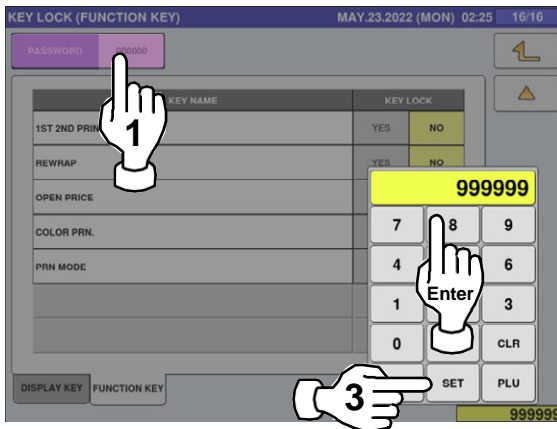

5. Press the Return button to complete the procedure.

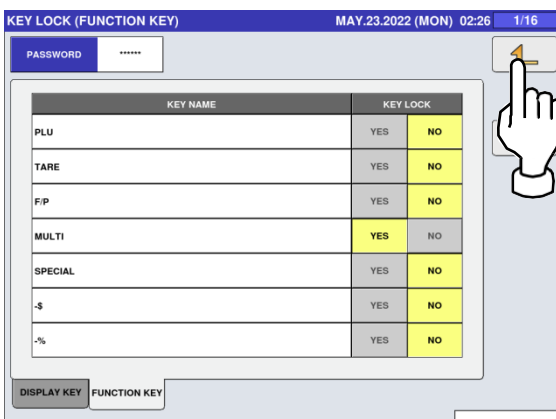

5.6 DATA STORAGE

1. Press the “DATA STORAGE” icon on the menu selection screen.

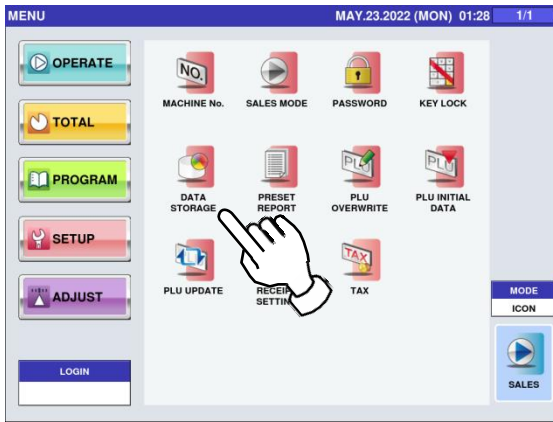

- ➔ The “Data Storage (Total Add)” screen is displayed.

To turn pages, press [▼] or [▲].

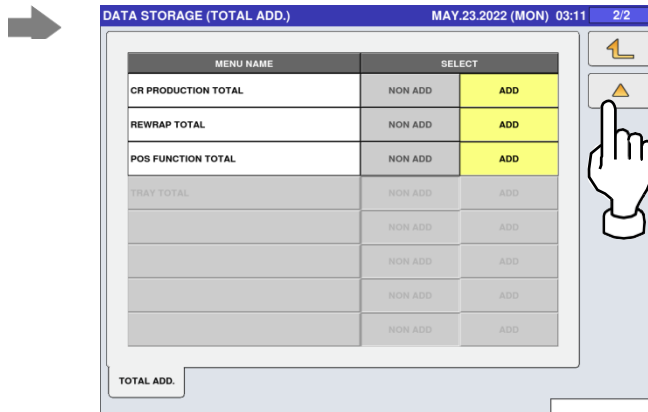
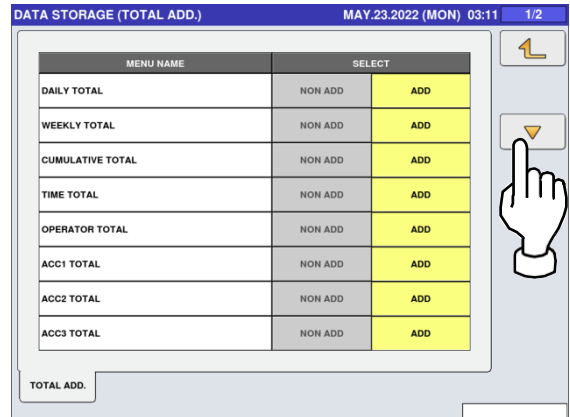

2. Press any selection buttons to set whether or not to apply the total addition function for each menu.

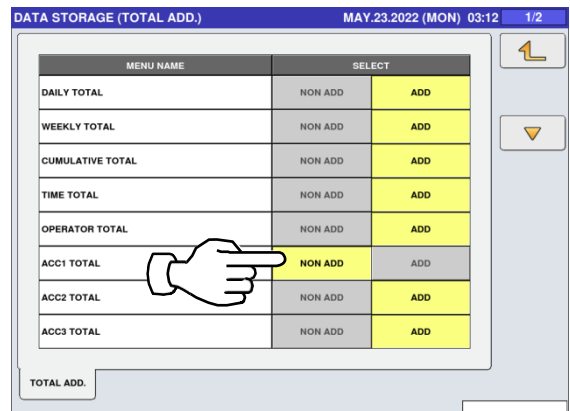

3. Press the Return button to complete the procedure.

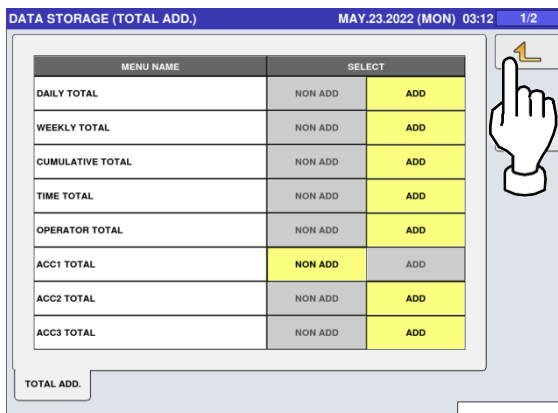

5.7 PRESET REPORT

1. Press the “PRESET REPORT” icon on the menu selection screen.

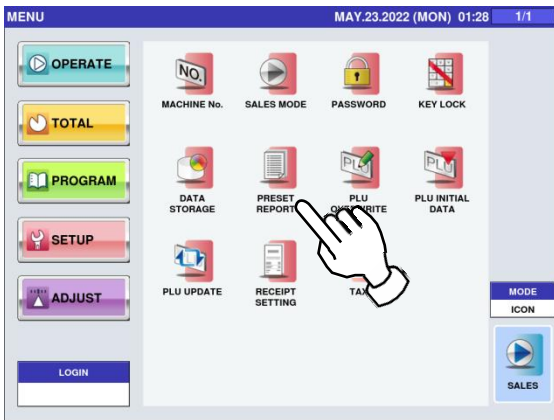

➔ The “Preset Report (Daily)” screen is displayed.

To turn pages, press [▼] or [▲].

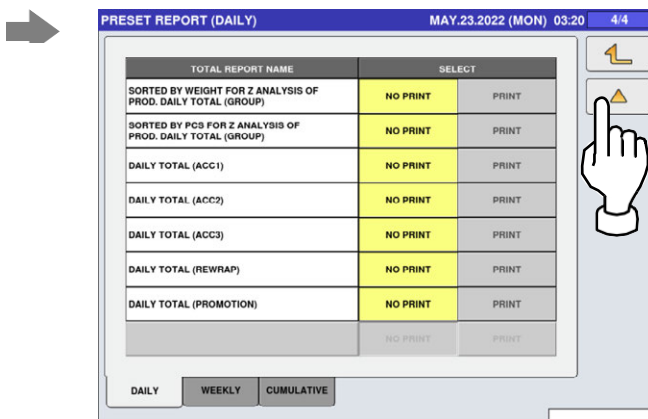
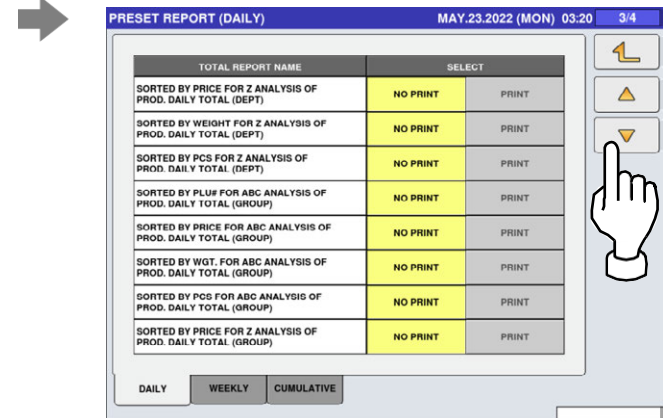
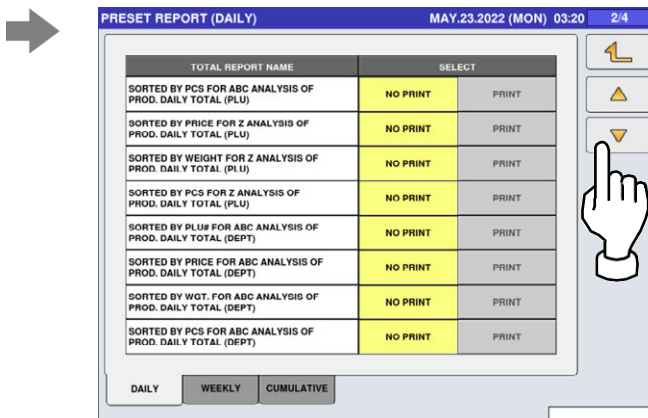
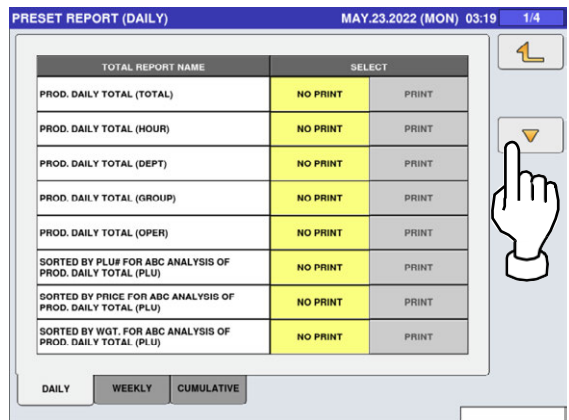

2. Press the “WEEKLY” tab to display the “Preset Report (Weekly)” screen.

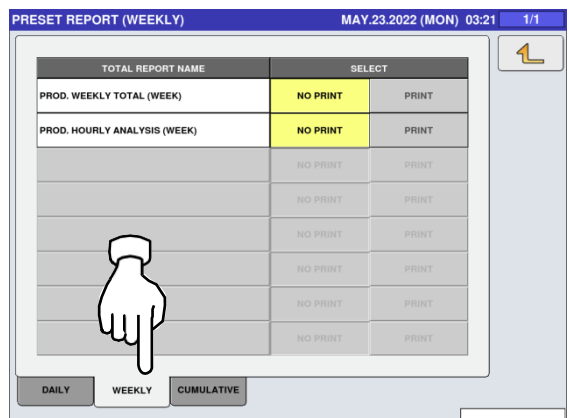

3. Press the “CUMULATIVE” tab to display the “Preset Report (Cumulative)” screen. To turn pages, press [▼] or [▲].

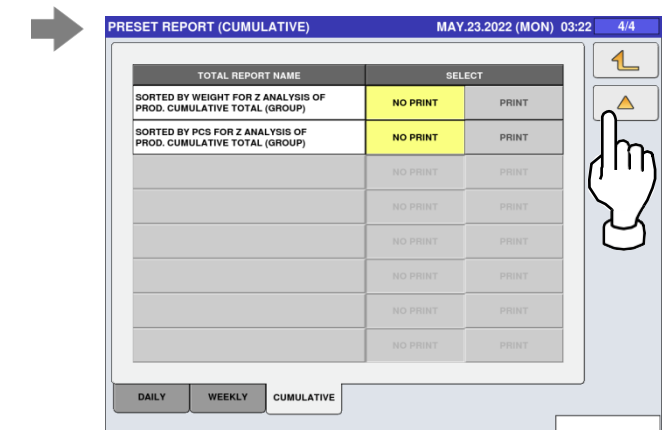
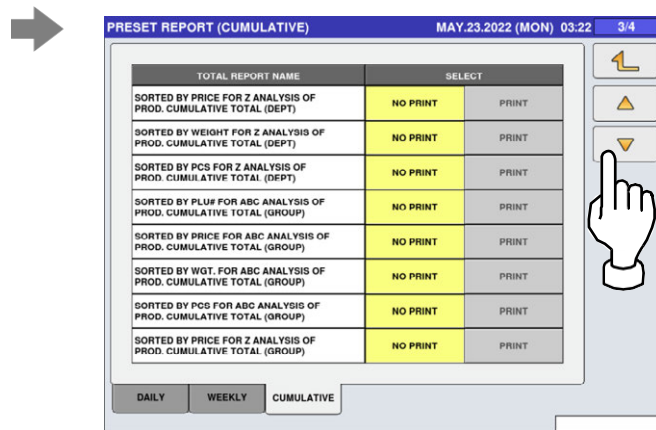
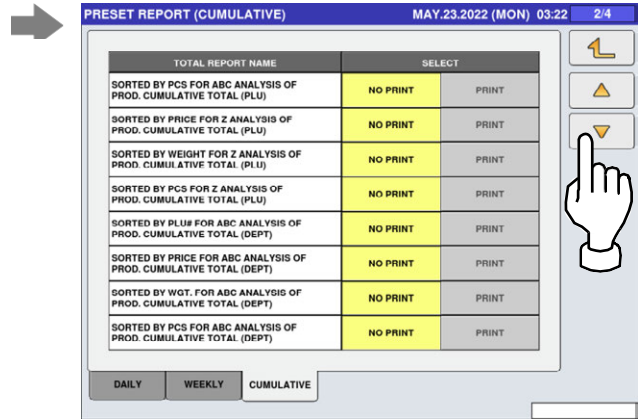
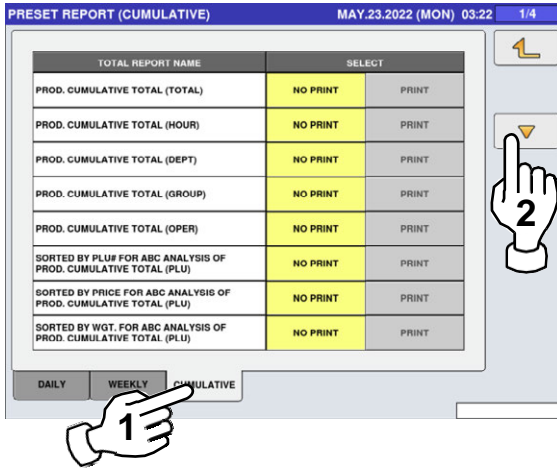

4. Select a desired report type by pressing the corresponding tab, and press any selection buttons to set whether or not to print the total.

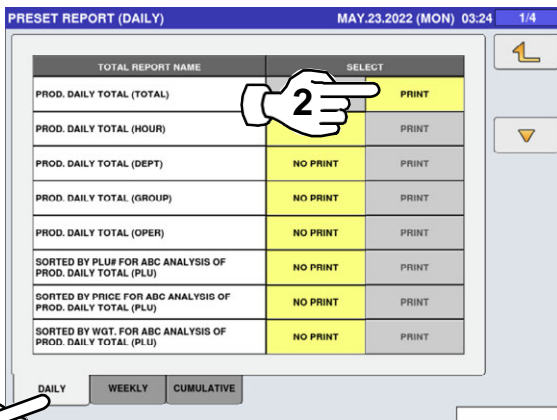

5. Press the Return button to complete the procedure.

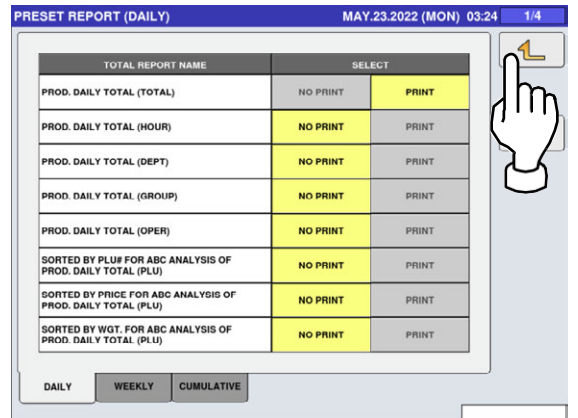

5.8 PLU OVERWRITE

1. Press the “PLU OVERWRITE” icon on the menu selection screen.

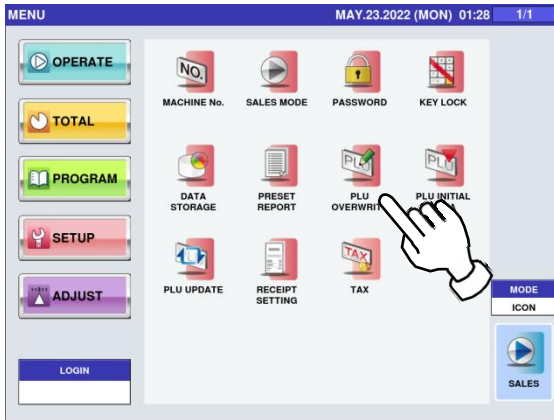

➔ The “PLU Overwrite” screen is displayed. To turn pages, press [▼] or [▲].

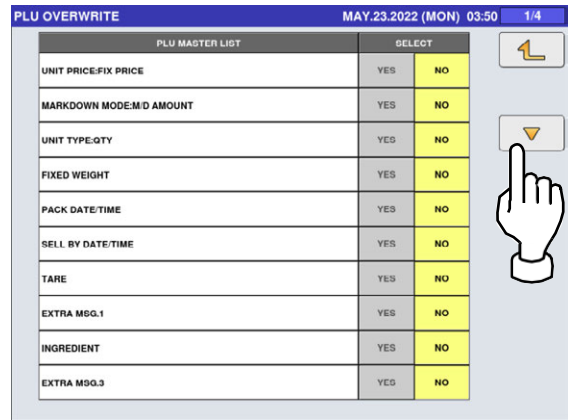

Note: Display items may vary depending on the country setting.

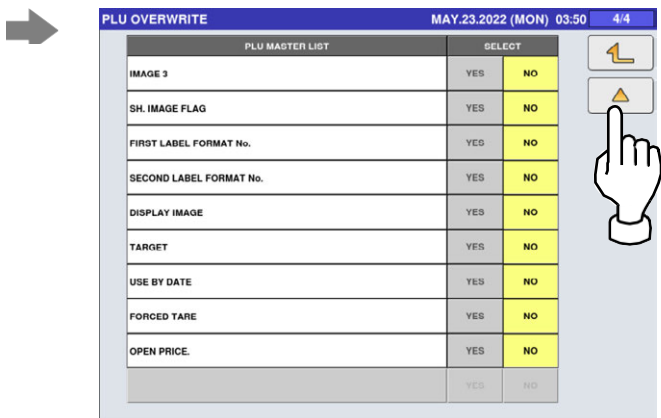
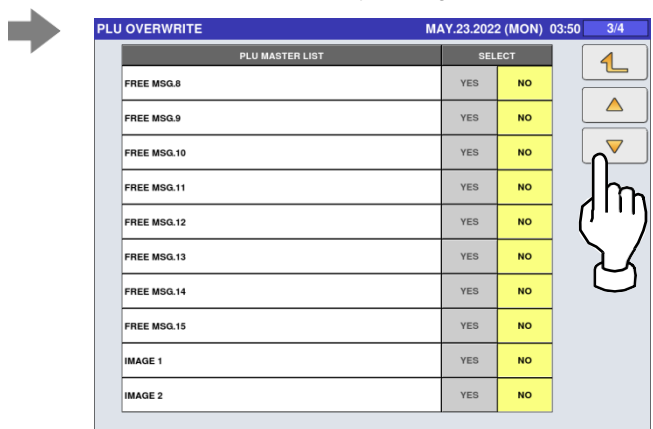

2.

Press any selection buttons to set whether or not to overwrite the item automatically.

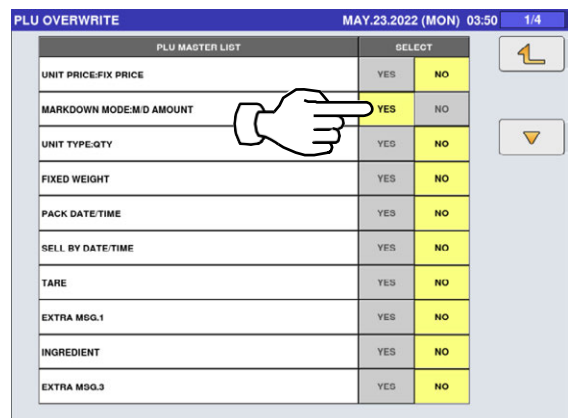

3. Press the Return button to complete the procedure.

PLU OVERWRITE MAY.23.2022 (MON) 03:50 1/4

PLU MASTER LIST	SELECT	
	YES	NO
UNIT PRICE/FIX PRICE	YES	NO
MARKDOWN MODE/MD AMOUNT	YES	NO
UNIT TYPE/QTY	YES	NO
FIXED WEIGHT	YES	NO
PACK DATE/TIME	YES	NO
SELL BY DATE/TIME	YES	NO
TARE	YES	NO
EXTRA MSG.1	YES	NO
INGREDIENT	YES	NO
EXTRA MSG.3	YES	NO



5.9 PLU INITIAL DATA

1. Press the “PLU INITIAL DATA” icon on the menu selection screen.

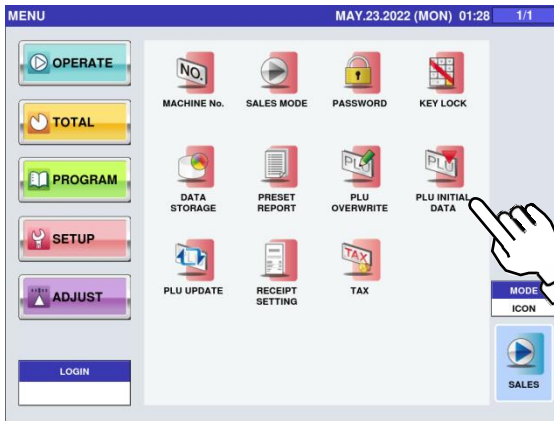

→ The “PLU Initial Data (Sale 1)” screen is displayed.

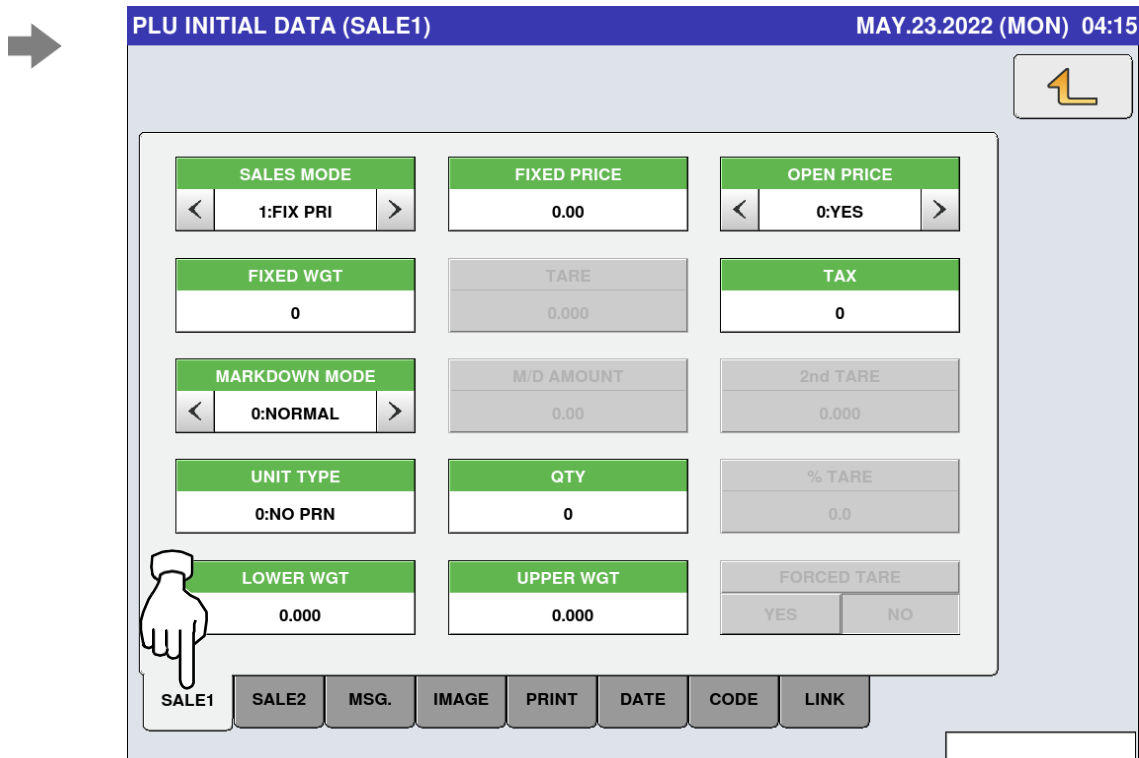
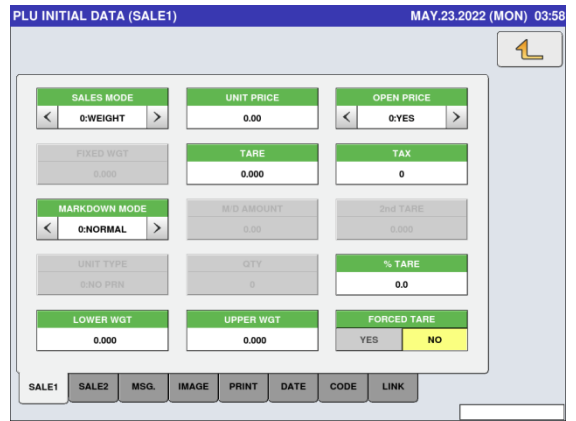

SALES MODE	Press [] or [] to select a desired sales mode. 0: Weight (for selling weighing products) 1: Fix price (for selling fixed price products) 2: Weight fix price (for selling weighing fixed price products) 3: Fix unit price (for selling fixed unit price products)
UNIT PRICE / FIXED PRICE	Enter a unit price or fixed price and press this field.
OPEN PRICE	Press [] or [] to select whether or not to allow an open price system. 0: Yes 1: No
FIXED WEIGHT	Enter a fixed weight and press this field.
TARE	Enter a tare weight and press this field.
TAX	Enter a desired number and press this field.

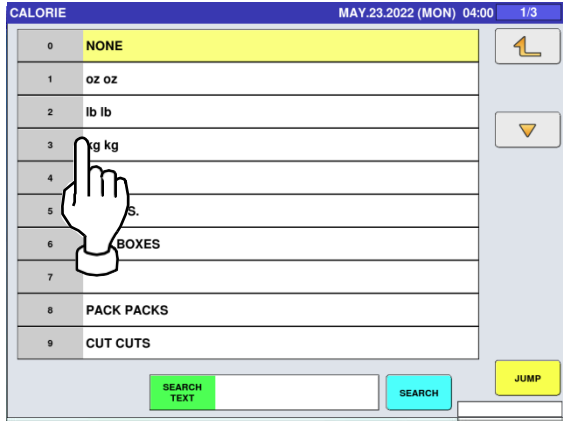
MARKDOWN MODE	<p>Press [] or [] to select a desired markdown mode.</p> <p>0: Normal price 1: Special price 2: Amount discount for total price 3: Percent discount for total price 4: Special unit price 5: Amount discount for unit price 6: Percent discount for unit price</p>
M/D AMOUNT	Enter a markdown amount or percentage and press this field.
2nd TARE	Enter a tare weight, and press this field.
UNIT TYPE	<p>Press the "UNIT TYPE" field to display the "Fix Price Symbol" screen. Then, press a desired field for selection.</p> 
QTY	Enter the packed quantity and press this field.
TARE	Enter a tare percentage and press this field.
LOWER WEIGHT	Enter the lower weight limit and press this field.
UPPER WEIGHT	Enter the upper weight limit and press this field.
FORCED TARE	Press [YES] or [NO] button to select whether or not to use the forced tare function.

2. Press the “SALE 2” tab to display the “PLU Initial Data (Sale 2)” screen.

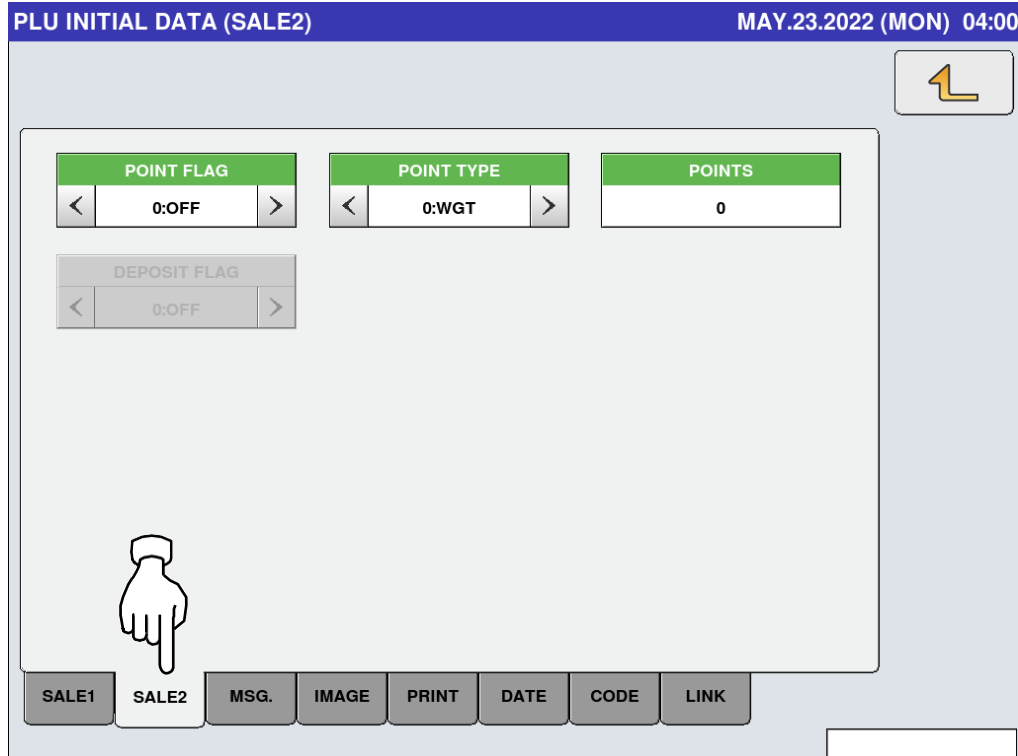

ITEM	DESCRIPTIONS
POINT FLAG	Press [] or [] to select whether or not to use the point flag. 0: OFF 1: ON
POINT TYPE	Press [] or [] to select a desired point type. 0: Weight 1: Fixed weight
POINTS	Enter a desired number and press this field.

3. Press the “MSG.” tab to display the “PLU Initial Data (Message)” screen.

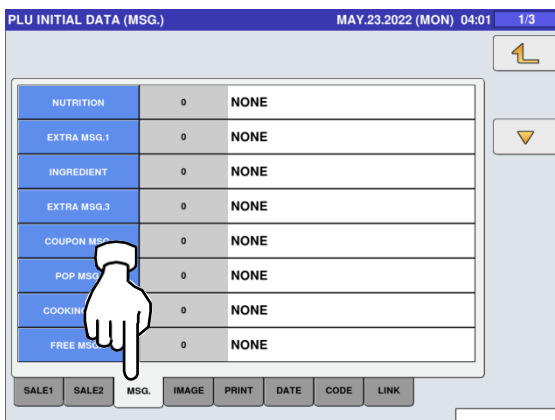

4. Press a desired field for selection.

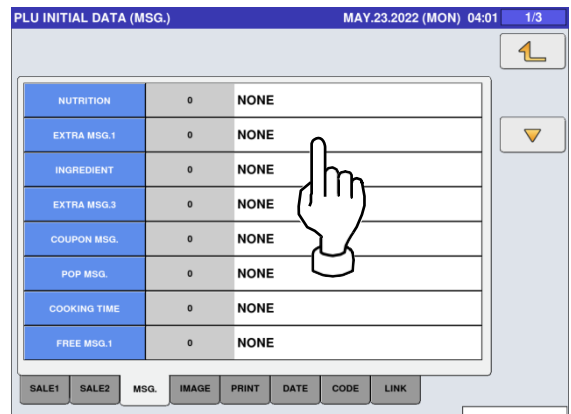

5. The “Extra Message” screen is displayed. Press a desired field for selection.

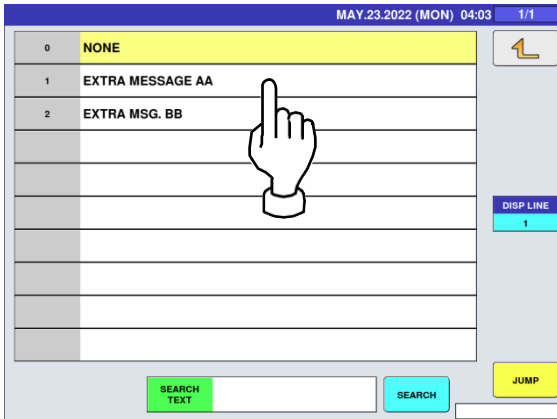

The selected message has been registered.

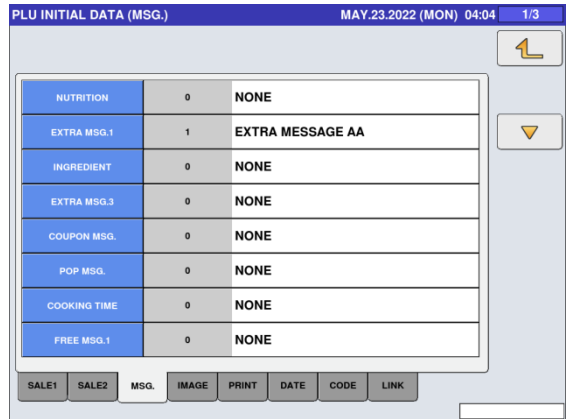

6. Press the “IMAGE” tab to display the “PLU Initial Data (Image)” screen.

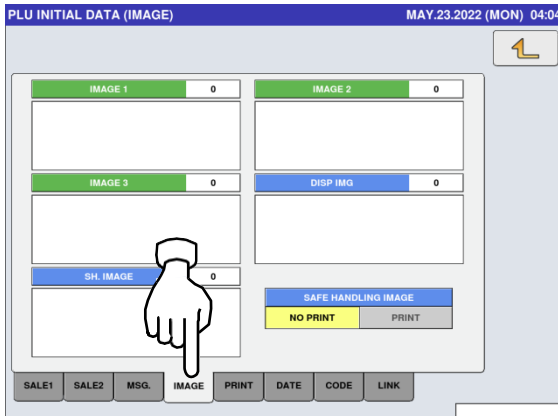

- 7.

Press a desired field for selection.

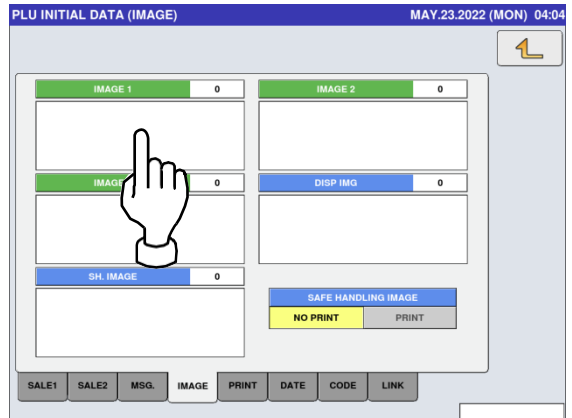

8. The “Image” screen is displayed.
Press a desired image for selection.

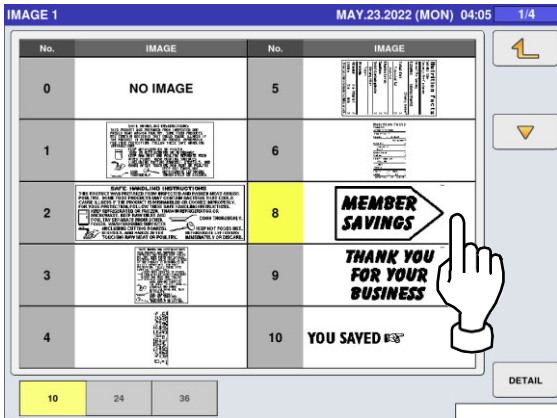

9. The selected image has been registered. Press [NO PRINT] or [PRINT] in the “Safe Handling Image” field to select whether or not to print the image.

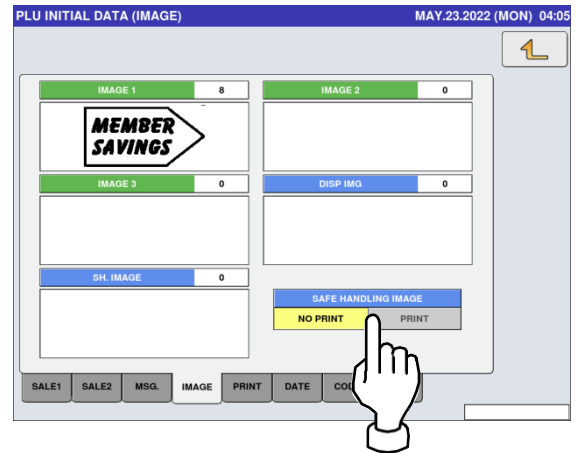

10. Press the Display Image field.

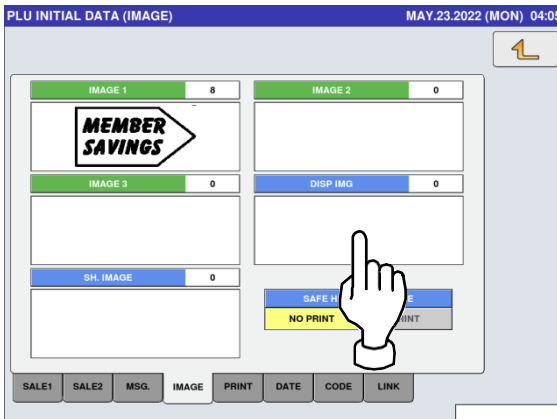

11. The “Display Image” screen is displayed. Press a desired image for selection.
Note: To use images stored in the USB memory, press [STORAGE] key. The movie file with the format of MPEG-4, 800 x 600 (SVGA), 10 Mbps, 25 FPS can also be used. Then, press the [SET] button.



12. The selected image has been registered. Press [NO PRINT] or [PRINT] in the “Safe Handling Image” field to select whether or not to print the image.

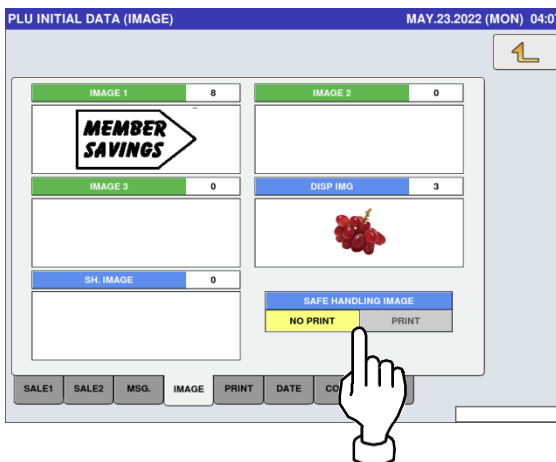

13.

Press the "PRINT" tab to display the "PLU Initial Data (Print)" screen.

PLU INITIAL DATA (PRINT) MAY.23.2022 (MON) 04:07

1st LABEL FORMAT No.(M) 0	2nd LABEL FORMAT No. 0	3rd LABEL FORMAT No. 0
1st LABEL FORMAT No.(A) 0		
1st LABEL PRINT < 1:YES >	2nd LABEL PRINT < 1:YES >	3rd LABEL PRINT < 2:NO >

SALE1
SALE2
MSG.
IMAGE
PRINT
DATE
CODE
LINK

ITEM	DESCRIPTIONS
1st LABEL FORMAT No. (M)	Enter a desired format number and press this field.
2nd LABEL FORMAT No.	Enter a desired format number and press this field.
1st LABEL FORMAT No. (A)	Enter a desired format number and press this field.
1st LABEL PRINT	Press [<input type="checkbox"/>] or [<input type="checkbox"/>] to select whether or not to print the first label. 1: Yes 2: No
2nd LABEL PRINT	Press [<input type="checkbox"/>] or [<input type="checkbox"/>] to select whether or not to print the second label. 1: Yes 2: No

14.

Press the “DATE” tab to display the “PLU Initial Data (Date)” screen.

PLU INITIAL DATA (DATE) MAY.23.2022 (MON) 04:08

<div style="border: 1px solid black; padding: 2px;"> <div style="background-color: #0056b3; color: white; padding: 2px; text-align: center;">PACK DATE PRINT</div> <div style="display: flex; justify-content: space-around; padding: 2px;"> YES NO </div> </div>	<div style="border: 1px solid black; padding: 2px;"> <div style="background-color: #0056b3; color: white; padding: 2px; text-align: center;">PACK TIME PRINT</div> <div style="display: flex; justify-content: space-between; padding: 2px;"> < 0:NO PRINT > </div> </div>	<div style="border: 1px solid black; padding: 2px; background-color: #ccc;"> <div style="background-color: #ccc; padding: 2px; text-align: center;">PACK TIME DATA</div> </div>
<div style="border: 1px solid black; padding: 2px;"> <div style="background-color: #0056b3; color: white; padding: 2px; text-align: center;">SB DATE PRINT</div> <div style="display: flex; justify-content: space-around; padding: 2px;"> YES NO </div> </div>	<div style="border: 1px solid black; padding: 2px;"> <div style="background-color: #0056b3; color: white; padding: 2px; text-align: center;">SB TIME PRINT</div> <div style="display: flex; justify-content: space-between; padding: 2px;"> < 0:NO PRINT > </div> </div>	<div style="border: 1px solid black; padding: 2px;"> <div style="background-color: #0056b3; color: white; padding: 2px; text-align: center;">SB TIME DATA</div> <div style="padding: 2px; text-align: center;">0 MIN.(S) AFTER</div> </div>
<div style="border: 1px solid black; padding: 2px;"> <div style="background-color: #0056b3; color: white; padding: 2px; text-align: center;">SHELF LIFE(days)</div> <div style="padding: 2px; text-align: center;">NEXT DAY(1 day)</div> </div>	<div style="border: 1px solid black; padding: 2px;"> <div style="background-color: #0056b3; color: white; padding: 2px; text-align: center;">USE BY DATE PRINT</div> <div style="display: flex; justify-content: space-around; padding: 2px;"> YES NO </div> </div>	<div style="border: 1px solid black; padding: 2px; background-color: #ccc;"> <div style="background-color: #ccc; padding: 2px; text-align: center;">UB DATE DATA</div> </div>

SALE1
SALE2
MSG.
IMAGE
PRINT
DATE
CODE
LINK

ITEM	DESCRIPTIONS
PACK DATE PRINT	Press [YES] or [NO] in this field to select whether or not to print the packed date.
PACK TIME PRINT	Press [] or [] to select a desired pack time printing method. 0: No print 1: Designated time 2: System clock time
PACK TIME DATA	This field is available only when “1: Designated time” is selected in “PACK TIME PRINT”. Enter the time and press this field.
SB DATE PRINT	Press [YES] or [NO] in this field to select whether or not to print the sell-by date.
SB TIME PRINT	Press [] or [] button to select a desired sellby time printing method. 0: No print 1: Designated time 2: Relative time
SB TIME DATA	This field is available only when “Yes” is selected in “SB TIME PRINT”. Enter the number of hours and press this field.
SHELF LIFE (days)	This field is available only when “Yes” is selected in “SB DATE PRINT”. Enter the number of days and press this field.
USE BY DATE PRINT	Press [YES] or [NO] in this field to select whether or not to print the use-by date.
UB DATE DATA	This field is available only when “Yes” is selected in “USE BY DATE PRINT”. Enter the number of hours and press this field.

15.

Press the “CODE” tab to display the “PLU Initial Data (Code)” screen.

ITEM	DESCRIPTIONS
ITEM CODE	Enter an item code and press this field.
REG CODE	Enter the register code and press this field.
POS FLAG	This field is available only when “1: PLU File” is selected in “POS REFERENCE”. Enter a POS flag number and press this field.
BARCODE	Enter a barcode number and press this field.
POS REFERENCE	Press [] or [] button to select a desired reference method. 0: Refer 1: PLU file
BARCODE TYPE	This field is available only when “1: PLU File” is selected in “POS REFERENCE”. Press this field to display the “Barcode Type” screen, and press a desired PLU type for selection.

CODE	DESCRIPTION	CODE	DESCRIPTION
000	REFER	010	ITF
001	EAN/UPC 13	011	Not Available
002	EAN/UPC 8		
003	10 DIGITS 13		
004	5 DIGITS 8		
005	GS1		
006	GS1 ST		
007	GS1 STO		
008	GS1 LIM		
009	GS1 EXP		

<p>POS FORMAT (WGT)</p>	<p>Press this field to display the “Barcode Format” screen, and press a desired barcode format for selection.</p> 
<p>TRACE ENABLE</p>	<p>Press [YES] or [NO] in this field to select whether or not to enable a traceability function.</p>
<p>DEPARTMENT No.</p>	<p>Press this field to display the “Department” screen. To set a department, press a desired field on the list, or press the “DEPARTMENT No.” field after numerical entry.</p>
<p>GROUP No.</p>	<p>Press this field to display the “Group” screen. To set a group, press a desired field on the list, or press the “GROUP No.” field after numerical entry.</p>

16. Press the “LINK” tab to display the “PLU Initial Data (Link)” screen.

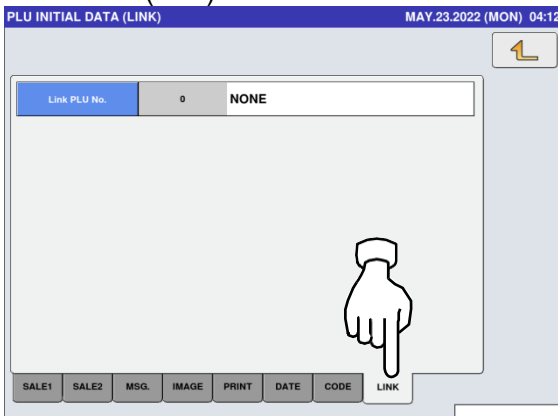

17. Press the Return button to complete the procedure.

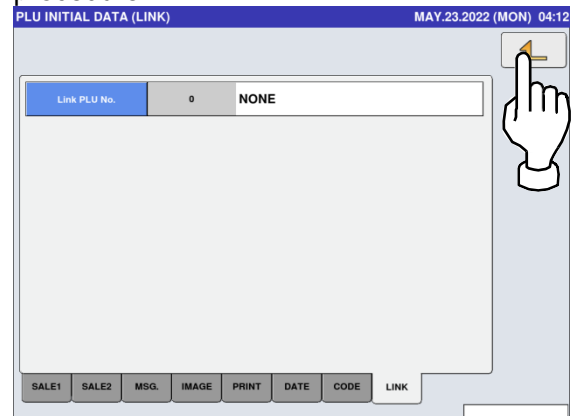

5.10 PLU UPDATE

1. Press the "PLU UPDATE" icon on the menu selection screen.

➔ The "PLU Update" screen is displayed. To turn pages, press [▼] or [▲].

Note: Display items may vary depending on the country setting.

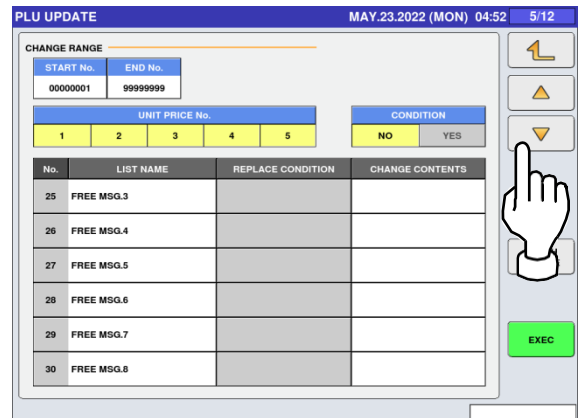
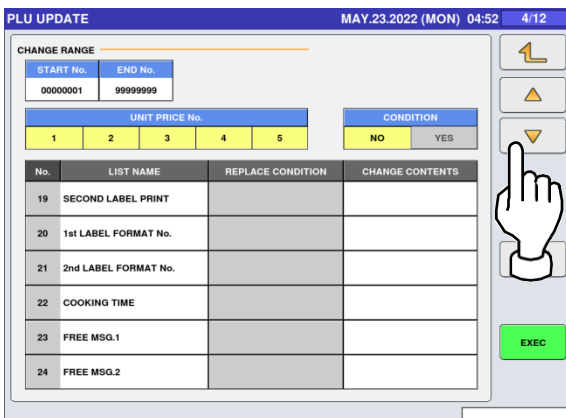
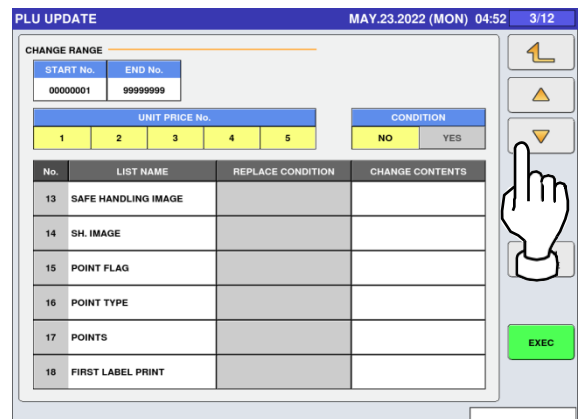
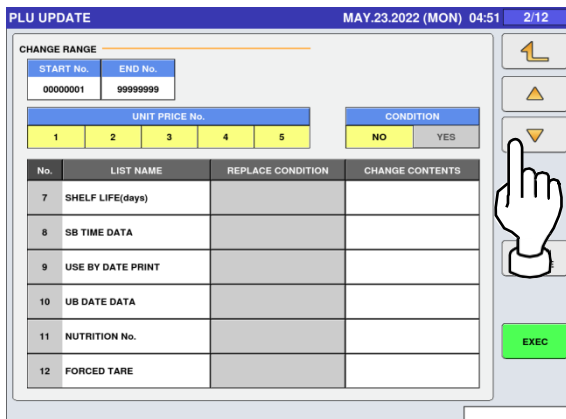
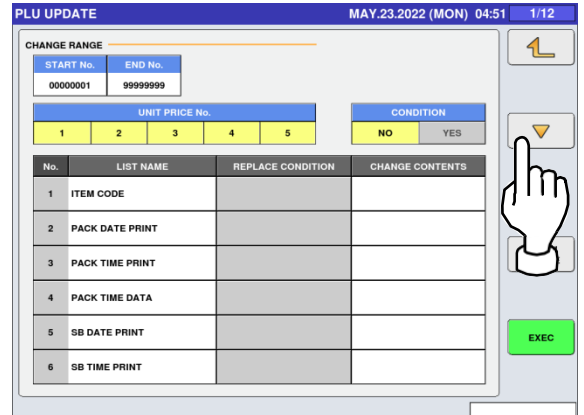
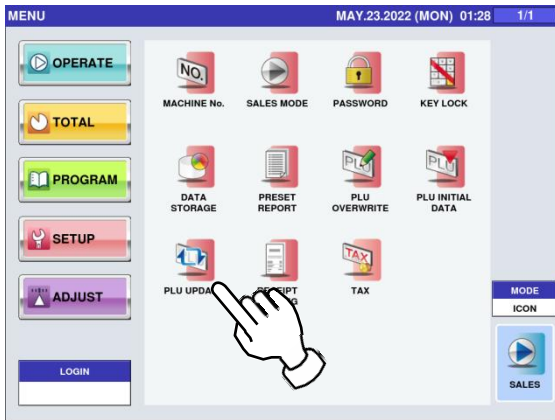

2. Enter the start and end numbers and press these fields respectively to specify the target PLUs.

3. Press desired items for selection.

PLU UPDATE MAY.23.2022 (MON) 04:55 1/12

CHANGE RANGE

START No.	END No.
00000001	99999999

UNIT PRICE No.					CONDITION	
1	2	3	4	5	NO	YES

No.	LIST NAME	REPLACE CONDITION	CHANGE CONTENTS
1	ITEM CODE	0	0
2	PACK DATE PRINT		
3	PACK TIME PRINT	2:CLOCK	2:CLOCK
4	PACK TIME DATA		
5	SB DATE PRINT	1:YES	1:YES
6	SB TIME PRINT		

BATCH DELETE EXEC



PLU UPDATE MAY.23.2022 (MON) 04:56 2/12

CHANGE RANGE

START No.	END No.
00000001	99999999

UNIT PRICE No.					CONDITION	
1	2	3	4	5	NO	YES

No.	LIST NAME	REPLACE CONDITION	CHANGE CONTENTS
7	SHELF LIFE(days)	NEXT DAY(1Day)	NEXT DAY(1Day)
8	SB TIME DATA	0 MIN.(s) AFTER	0 MIN.(s) AFTER
9	USE BY DATE PRINT	2:NO	2:NO
10	UB DATE DATA		
11	NUTRITION No.		
12	FORCED TARE		

BATCH DELETE EXEC

4. Press the [EXEC] button to update the selected items.

PLU UPDATE MAY.23.2022 (MON) 04:56 2/12

CHANGE RANGE

START No.	END No.
00000001	99999999

UNIT PRICE No.					CONDITION	
1	2	3	4	5	NO	YES

No.	LIST NAME	REPLACE CONDITION	CHANGE CONTENTS
7	SHELF LIFE(days)	NEXT DAY(1Day)	NEXT DAY(1Day)
8	SB TIME DATA	0 MIN.(s) AFTER	0 MIN.(s) AFTER
9	USE BY DATE PRINT	2:NO	2:NO
10	UB DATE DATA		
11	NUTRITION No.		
12	FORCED TARE		

BATCH DELETE EXEC

5. Press [EXEC] to renew all data, or [STOP] to go back.

PLU UPDATE MAY.23.2022 (MON) 04:56 2/12

ALL REUPDATE CHECK

IT IS OK TO RENEW ALL DATA FOR PRODUCT?

14003 - 0000

EXEC STOP

5.11 RECEIPT SETTING

1. Press the "RECEIPT SETTING" icon on the menu selection screen.

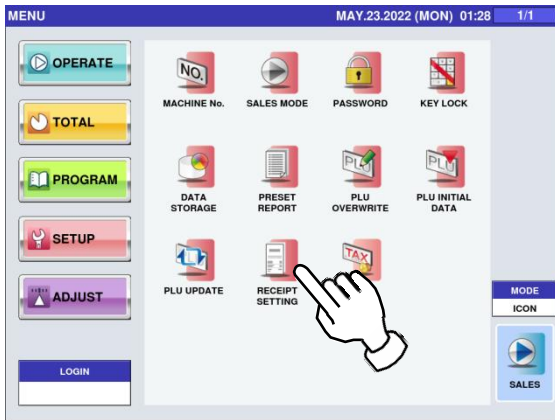

2. The "Receipt Setting (Title)" screen is displayed. To edit the header and footer titles, press the corresponding field.



3. The text edit screen is displayed. Edit the text according to the procedure described in Appendix "Text Editing".



4. To finish the editing, press the Return button on the screen.



5. The confirmation screen is displayed. To confirm changes, press [SAVE]. To undo changes, press [CANCEL].

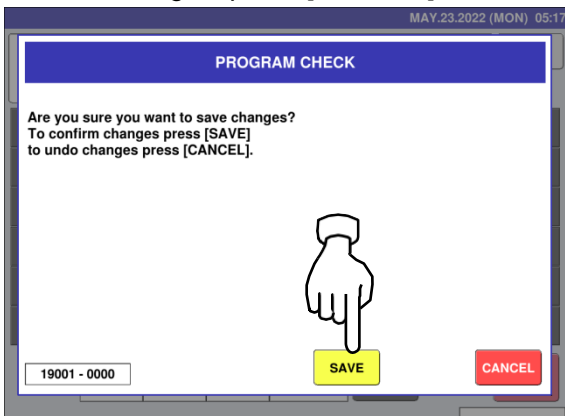

6. To edit the header and footer logo images, press the corresponding field.

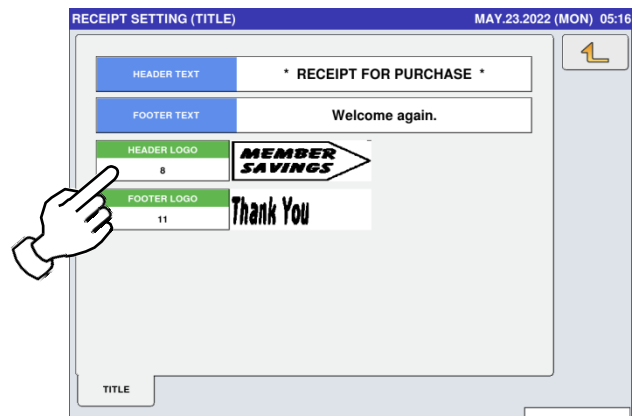

7. The "Header Image" screen is displayed.

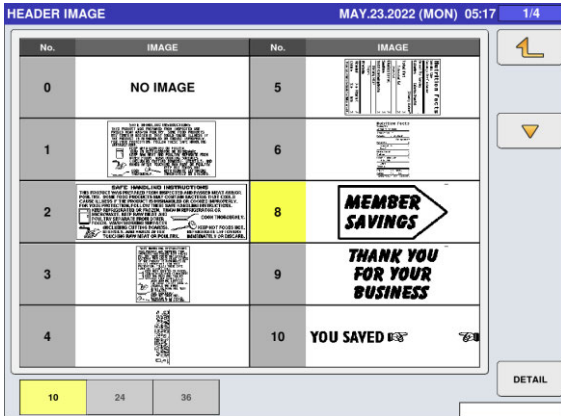

8. Press a desired image for selection.

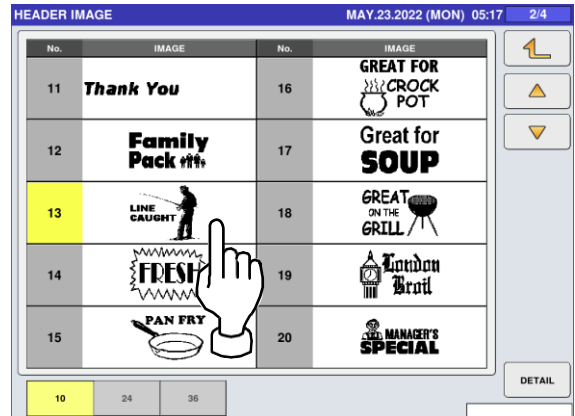

9. The selected logo image has been registered.

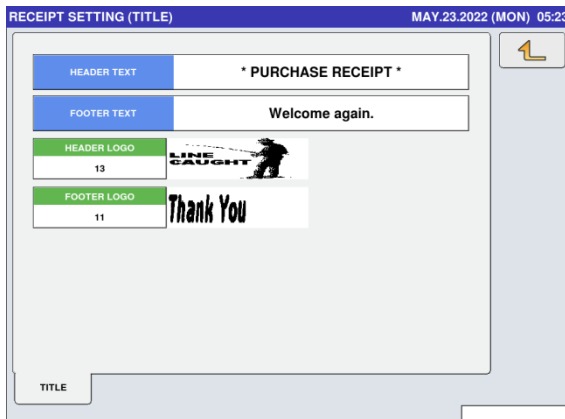

5.12 TAX REGISTRATION

Press the "TAX" icon on the menu selection screen.

1.

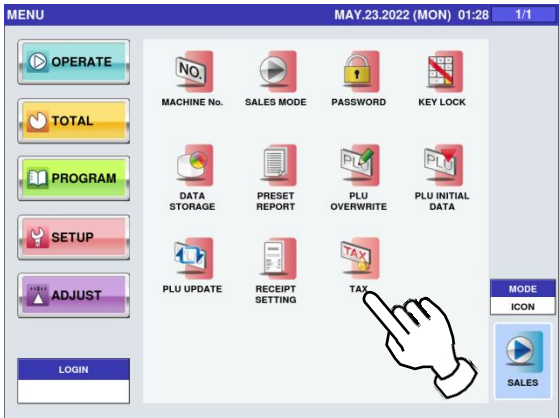

The "Tax" screen is displayed.

2.

TAX					MAY.23.2022 (MON) 05:18	
TAX No.	TAX TYPE			TAX RATE		
0	EXCLUDED	INCLUDED	EXEMPT	5.00 %		
1	EXCLUDED	INCLUDED	EXEMPT	5.00 %		
2	EXCLUDED	INCLUDED	EXEMPT	5.00 %		
3	EXCLUDED	INCLUDED	EXEMPT	5.00 %		
4	EXCLUDED	INCLUDED	EXEMPT	5.00 %		
5	EXCLUDED	INCLUDED	EXEMPT	5.00 %		
6	EXCLUDED	INCLUDED	EXEMPT	5.00 %		
7	EXCLUDED	INCLUDED	EXEMPT	5.00 %		
8	EXCLUDED	INCLUDED	EXEMPT	5.00 %		
9	EXCLUDED	INCLUDED	EXEMPT	5.00 %		

ITEM	DESCRIPTIONS
TAX TYPE	Press a desired tax type for selection. Exclusive tax Inclusive tax Tax exemption
TAX RATE	Enter a numerical value and press the applicable field.

ADJUSTMENT MODE

6.1 ADJUSTMENT MODE ENTRY / EXIT

1. Ensure that the initial screen is displayed. Then, press the Return button on the screen to display the "Menu" screen.

Note: The content of the initial screen may differ depending on the settings on your machine.

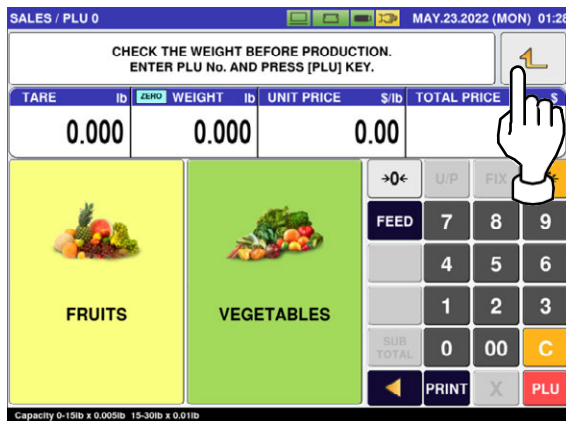

2. The "Menu" screen is displayed. Then, press the [ADJUST] button.

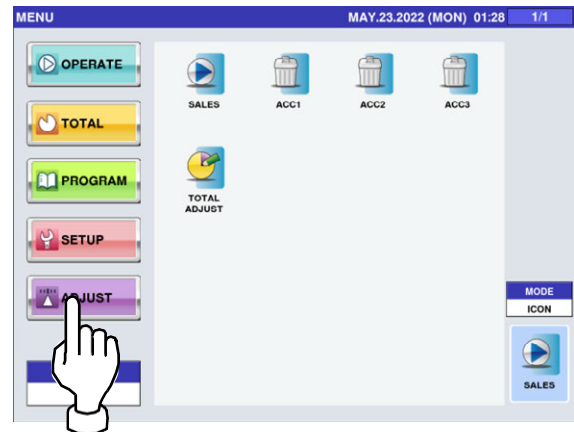

➔ The adjustment menu selection screen is displayed.

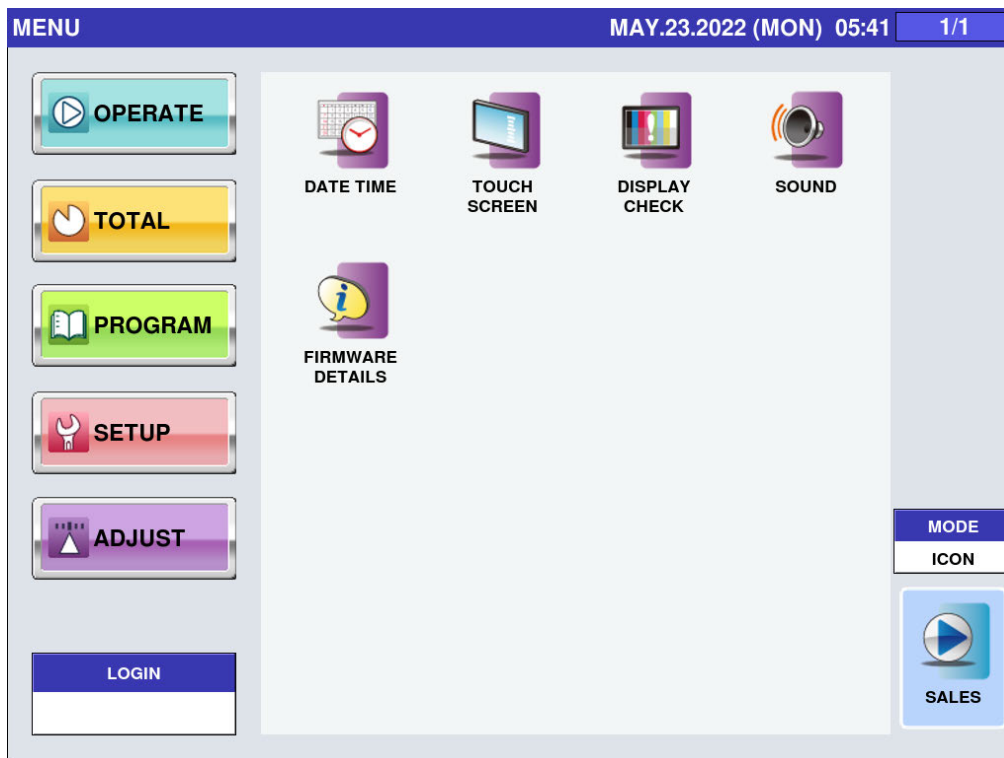

Note: To exit the Adjustment Mode, press the [SALES] button.

6.2 DATE / TIME

1. Press the “DATE TIME” icon on the menu selection screen.

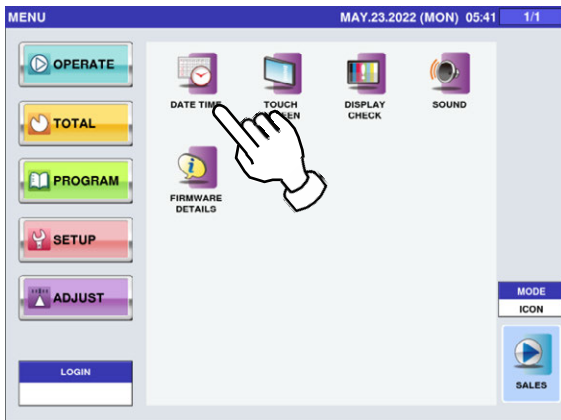

→ The “Date / Time” screen is displayed.

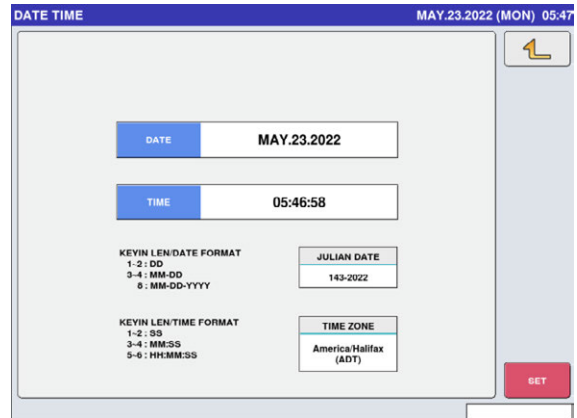

2. To change the date, press the “DATE” field and enter a new date data. Then, press the [SET] key.
EXAMPLE May 23, 2022

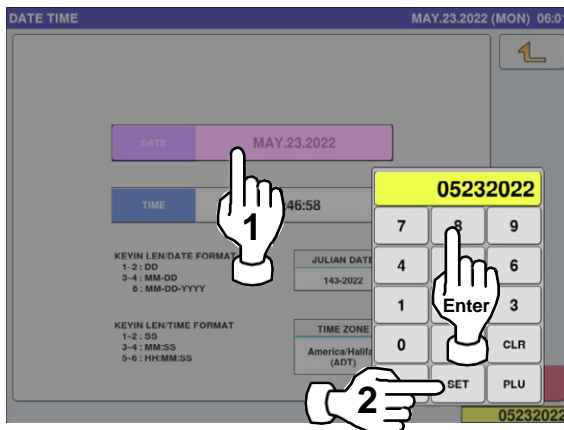

3. To change the time, press the “TIME” field and enter a new time data. Then, press the [SET] key.
EXAMPLE 13:50:00



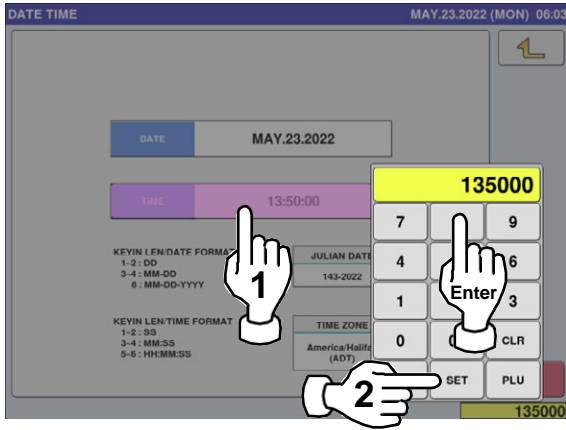

4. To register new date and time, press the [SET] button.

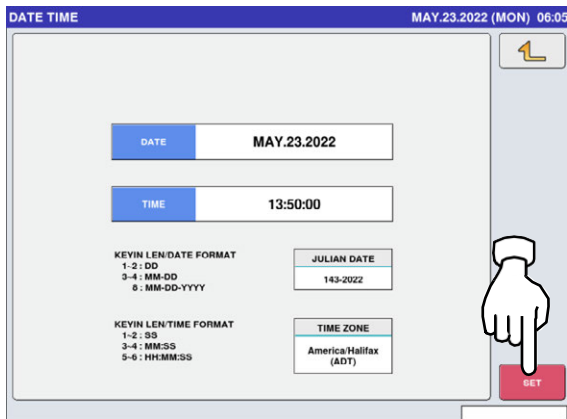

5. The confirmation screen is displayed. Press [EXEC] to continue, or [STOP] to go back.

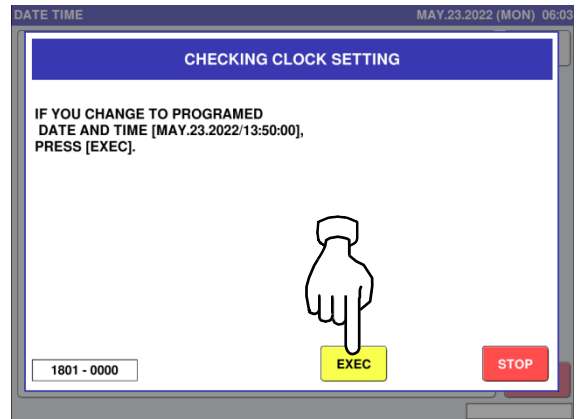

6.3 TOUCH SCREEN

1. Press the "TOUCH SCREEN" icon on the menu selection screen.

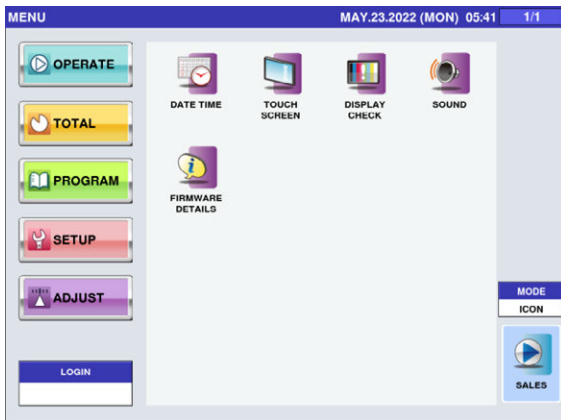

➔ The "Touch Screen" screen is displayed.

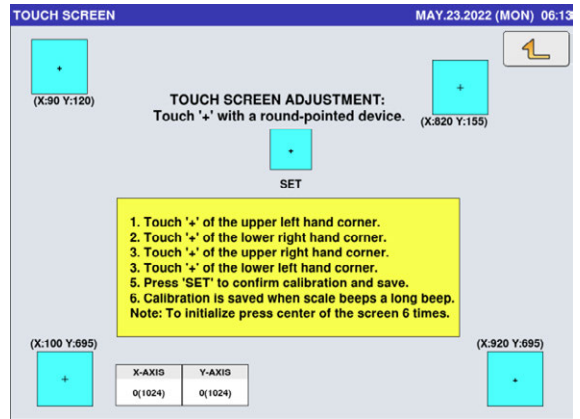

2. Press [+] on the button at the upper left of the screen with a round-pointed device.
Press [+] on the button at the lower right of the screen.

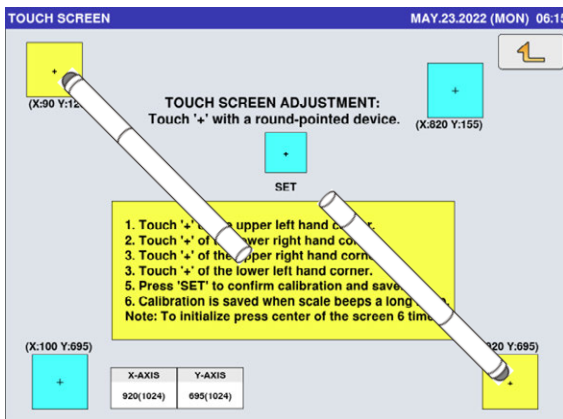

➔ Press [+] on the button at the upper right of the screen with a round-pointed device.
Press [+] on the button at the lower left of the screen.

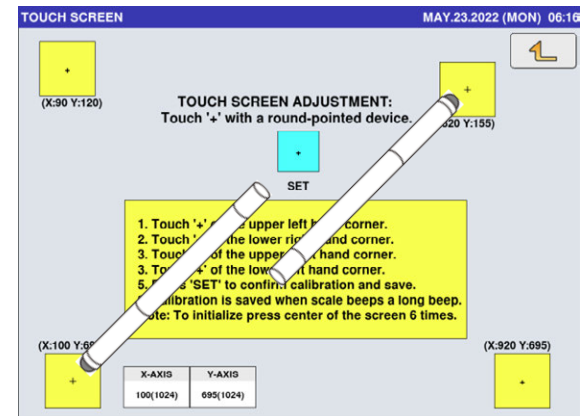

3. Press [+] on the [SET] button to confirm calibration and save.

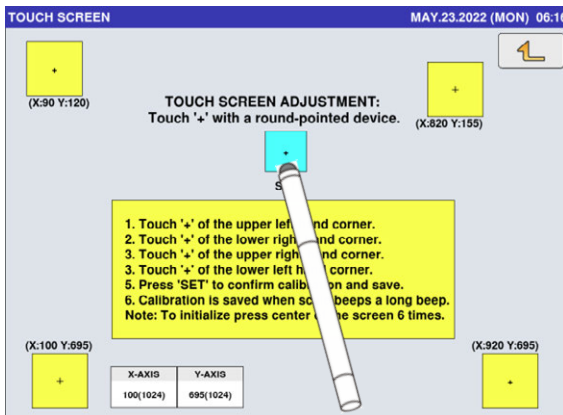

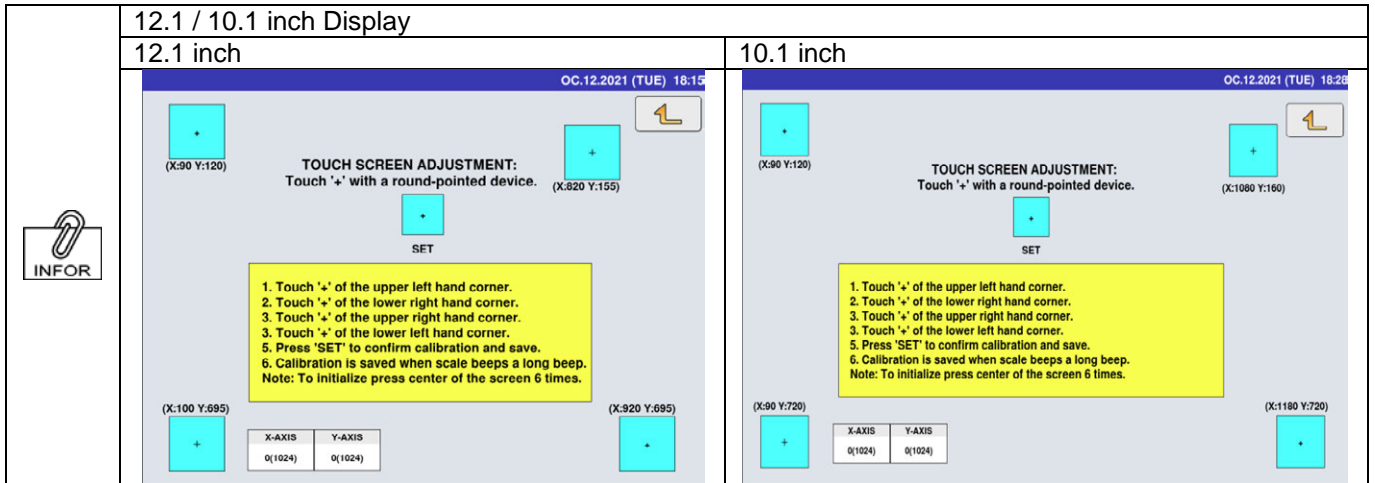

6.4 DISPLAY CHECK

1. Press the “DISPLAY CHECK” icon on the menu selection screen.

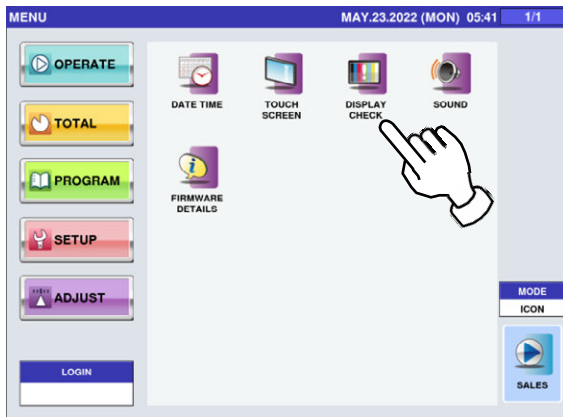

2. The “Display Check (Vertical)” screen is displayed. Press [-] or [+] to adjust the vertical brightness for operator and customer displays.

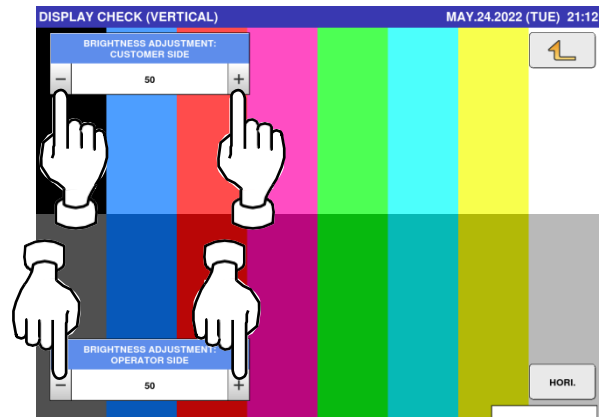

3. Press the [HORIZONTAL] button to change to the horizontal display check screen.

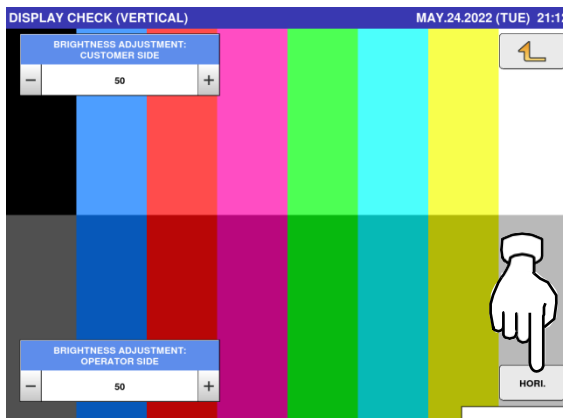

4. The “Display Check (Horizontal)” screen is displayed. Press [-] or [+] to adjust the horizontal brightness for operator and customer displays.

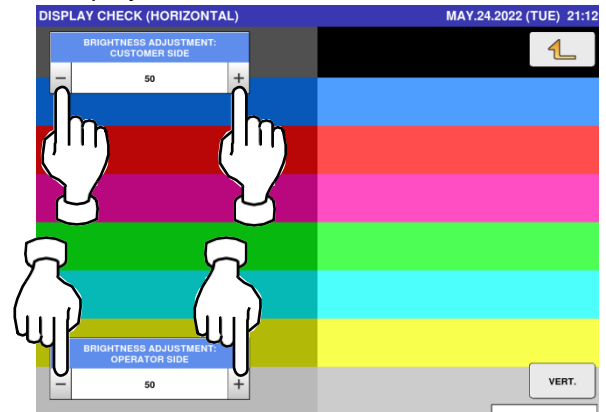

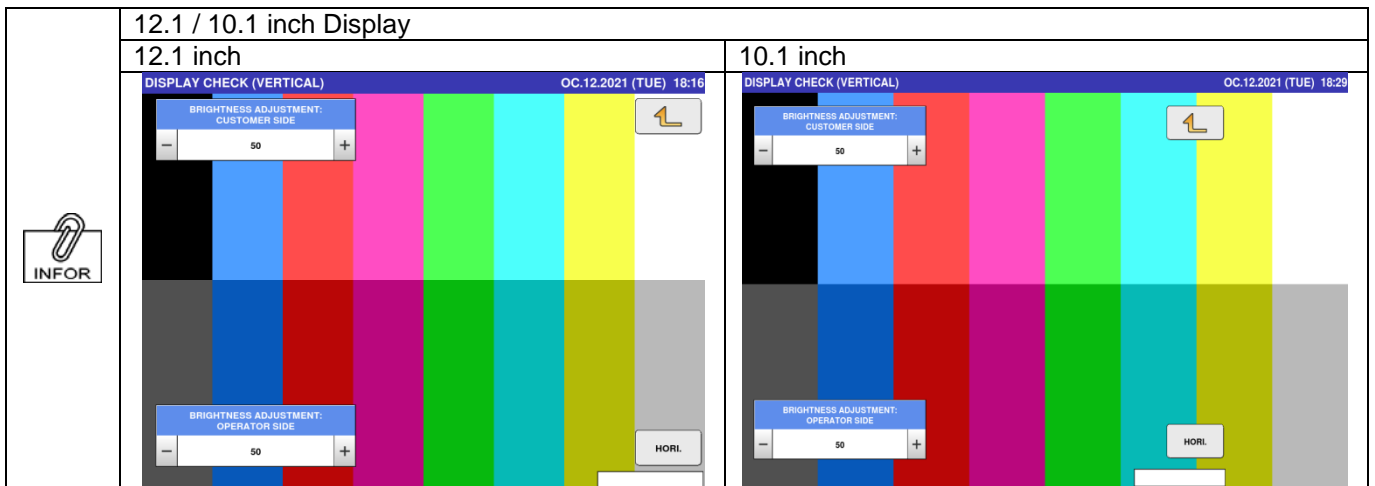

6.5 SOUND

1. Press the “DISPLAY CHECK” icon on the menu selection screen.

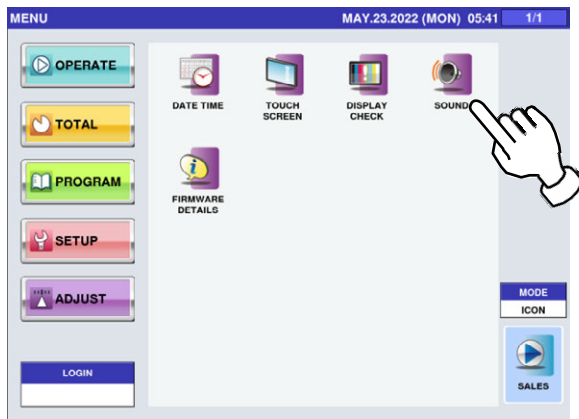

2. The “Sound” screen is displayed. To set sound levels, press “ON” in the “Sound” field and press [<] or [>].

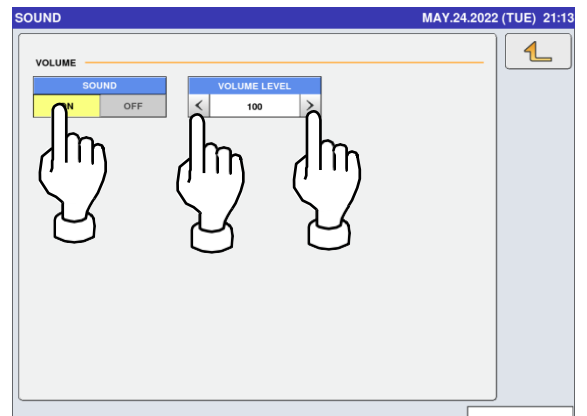

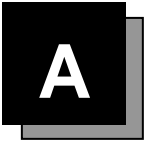

TEXT EDITING

A.1 EDIT SCREENS

Upper-case mode



Used to finalize the editing

Displays the called number

Displays the number of input characters

Displays the number of remaining characters





Press this field to select a desired font size

Press this field to select a desired font style

Lower-case mode

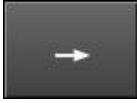
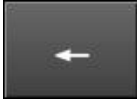

A.2 EDIT KEYS

Lower Case	Used to switch between lower-case and upper-case character modes.	Normal	Used to specify a normal character style.
New Line	Used to begin a new line.	Bold	Used to specify a bold character font style.
Line Delete	Used to delete a line text at the place where the cursor is placed.	Reverse	Used to specify a reverse character font style.
Char Delete	Used to delete a character at the place where the cursor is placed.		Used to move the cursor to the right.
Back Space	Used to delete a character by moving the cursor back by one character.		Used to move the cursor to the left.
Under Line	Used to specify an underlined character font style.		Used to move the cursor up.
Italic	Used to specify an Italic character style.		Used to move the cursor down. Also used to select characters for changing the style.
COPY	Used to copy the original data to the current data.		Used to enter a space.
ERASE	Used to erase the full text currently being called.		

Used to display the following key screen.

Key Page

EXTRA MSG.1 / EDIT
MAY.24.2022 (TUE) 21:41

G O U D A C H E E S E

1	2	3	4	5	6	7	8	9	0
À	Á	Â	Ã	Ä	Å	Æ	Ç	È	É
Ê	Ë	Ì	Í	Î	Ï	Ð	Ñ	Ò	Ó
Ô	Õ	Ö	Ø	Ù	Ú	Û	Ü	Ý	Þ
Lower Case	#	%	*	&	New Line	Line Delete	Char Delete	↑	Back Space
Shift	Key Page	Under Line	Italic	Normal	Bold	Reverse	←	↓	→

No.	CHAR	REMAIN	STYLE	FONT
3	012	6485	/	30x15/30x15

COPY

ERASE

Used to display the following key screen.

Shift

EXTRA MSG.1 / EDIT MAY.24.2022 (TUE) 21:47

G O U D A C H E E S E

1	2	3	4	5	6	7	8	9	0
!	@	\$	€	±	^	°	{	}	:
;	"	'	<	>	.	?	/	~	`
-	+	=	_	[]	\		()
Lower Case	#	%	*	&	New Line	Line Delete	Char Delete	↑	Back Space
Shift	Key Page	Under Line	Italic	Normal	Bold	Reverse	←	↓	→

No.	CHAR	REMAIN	STYLE	FONT		
3	012	6485	/	30x15/30x15	COPY	ERASE

A.3 INPUT EXAMPLES

A.3.1 TEXT EDITING

1. Enter desired characters using alpha-numeric keys.

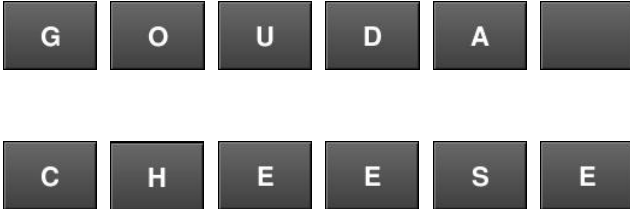

Upper-case characters



Lower-case characters



2. To begin a new line, press the [New Line] key.



Enter desired characters.



3. To register the editing, press the Return button.



4. The confirmation screen is displayed. To confirm changes, press [SAVE]. To undo changes, press [CANCEL].

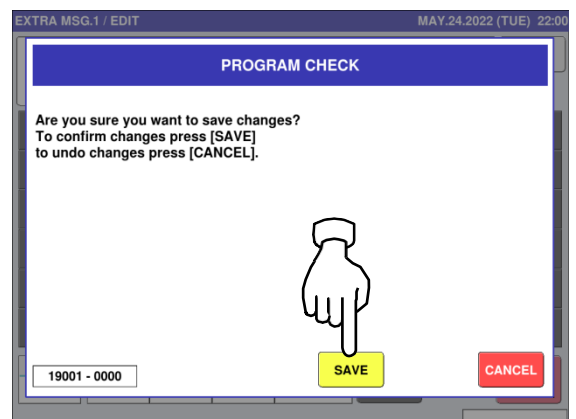

A.3.2 FONT STYLE SELECTION

Press the following keys to select a desired font style.

1.



Note: The selected font style is displayed in the “STYLE” display field.

2.

Enter desired characters using alpha-numeric keys.

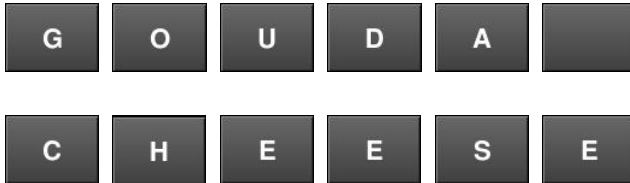

3. Press the Return key to register the editing.



4. The confirmation screen is displayed. To confirm changes, press [SAVE]. To undo changes, press [CANCEL].

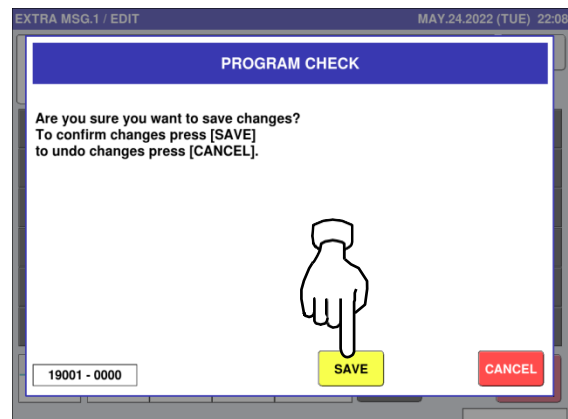

A.3.3 LINE DATA DELETION

1. Press the [Line Delete] key to delete the line data.

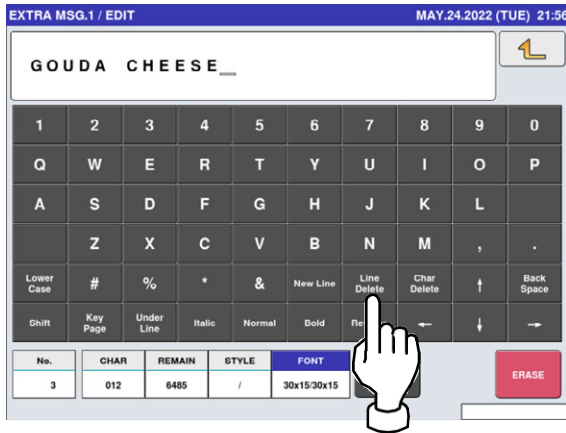

2. The line data has been deleted. Press the Return button to register the deletion.

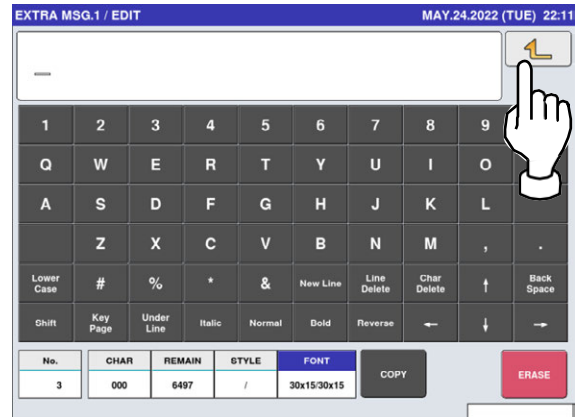

3. The confirmation screen is displayed. To confirm changes, press [SAVE]. To undo changes, press [CANCEL].

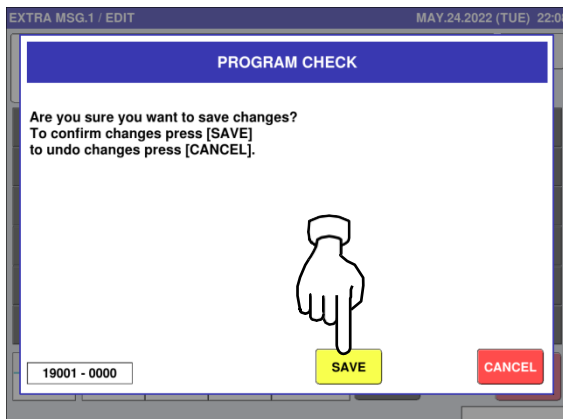

A.3.4 DATA ERASE

1. Press the [ERASE] button to delete the full text currently being called.

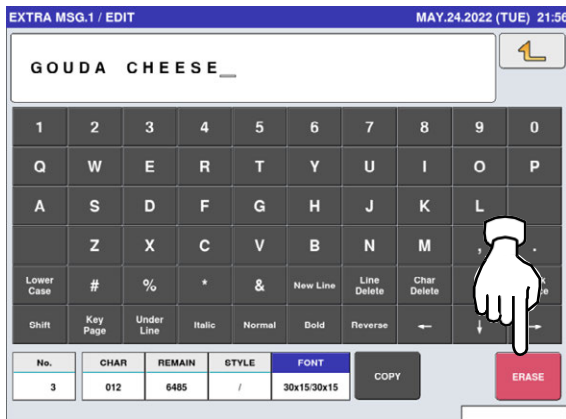

2. The confirmation screen is displayed. Press [EXEC] to continue, or [STOP] to go back.

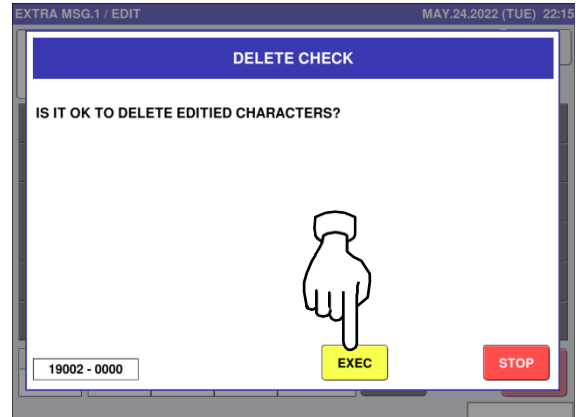

3. The full text has been erased.

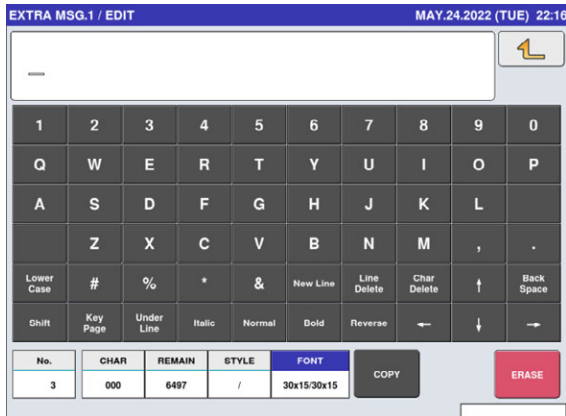

A.3.5 DATA COPY

1. To call up a desired string of characters, press the INPUT field at the bottom right of the screen to display the keypad.
2. Then, enter a numerical value and press the [SET] key on the keypad.

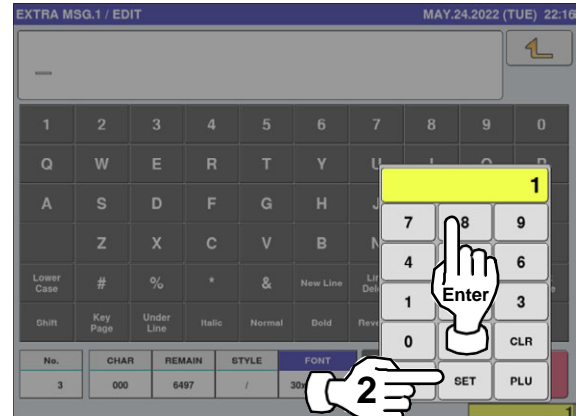

3. Press the [COPY] key while the number is displayed in the INPUT field.
4. The confirmation screen is displayed. Press [EXEC] to continue, or [STOP] to go back.

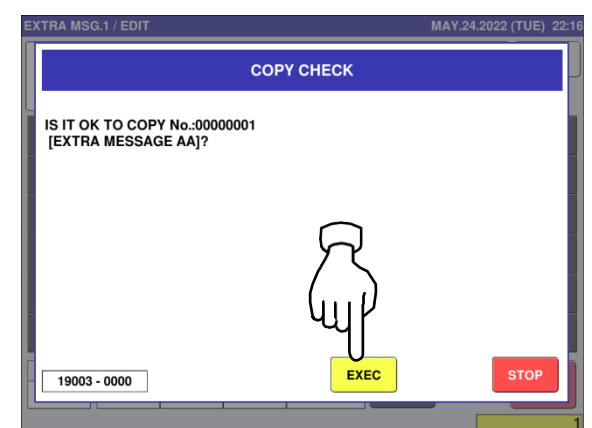
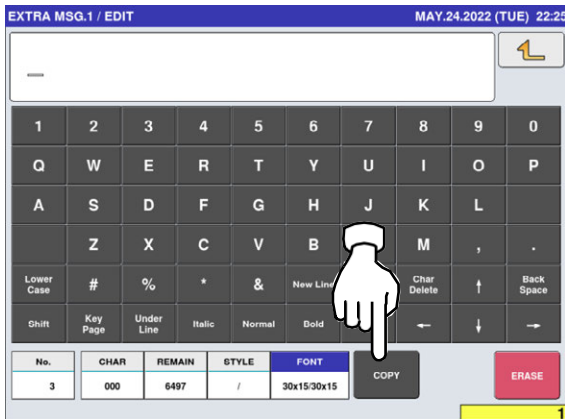

5. The specified text has been copied.





© Rice Lake Weighing Systems Content subject to change without notice.

230 W. Coleman St. • Rice Lake, WI 54868 • USA USA: 800-472-6703 • International: +1-715-234-9171