

UNI-5 Series

Scale and Printer

Service Manual



RICE LAKE
RETAIL SOLUTIONS

ISHIDA



- Do not carry out installation, operation, service or maintenance until the contents of this manual are thoroughly understood.
- Keep this manual available always so that it can be referred to as necessary for the purposes of installation, operation, service, and maintenance.

The use of this manual is for our service personnel and persons authorized to carry out maintenance work of this machine. The use of this manual by any person other than the above is strictly prohibited.

ISHIDA CO., LTD.

Issued in May 2012

Revised in April 2023

© **ISHIDA Co., Ltd. 2023 All rights are reserved.**

No part of this publication may be reproduced, stored in a retrieval system, or transmitted in any form or by any means mechanical, electronic, photocopying, recording, or otherwise without prior written permission of ISHIDA.

Revision History

Version	Date	Description
1	November, 2012	The 1 st edition
2	May, 2017	The 2 nd edition
3	May, 2021	The 3 rd edition Added Technical Report SC216106 "Changing Power Supply Unit along with Changing CE Declaration".
4	April, 2023	The 4 th edition - Added two Technical Reports as follows at the beginning. *SC236115" Item codes of operation panel's LCD unit are changed (Target: USA, Canada, and Taiwan)" *SC236116 "Item codes of operation panel's LCD unit are changed (Target: Not UL Standards)" -Added the notification about SC236115 and SC236116 at "3.1.4 Operation panel".
5	April, 2023	The 5 th edition -Deleted the description about "Insert" key at "9.1.1.2 Keys for Text Editing" because of wrong description. -Deleted "9.1.4 Character selection" because of wrong description.

Notices

Important notice

Those who handle the machine must be aware of the hazards involved. These dangers may not be obvious, so it is imperative to follow the instructions detailed in this manual when installing, operating, inspecting, or servicing the machine. Therefore, we recommend that you thoroughly read and understand this manual before installing, operating, inspecting, or servicing the machine. ISHIDA is not liable for any damage, loss or injury that results from incorrect operation, insufficient caution, unauthorized modifications to the machine, or failure to follow the instructions contained in this manual.

Limitations of Liability

ISHIDA assumes no responsibility for special, indirect, or consequential damages, loss of profits or commercial loss in any way connected with the machine, whether such claim is based on contract, warranty, negligence, or strict liability.

ISHIDA assumes no responsibility for the user's programming of this machine, or any consequence thereof.

In no event shall ISHIDA be responsible for warranty, repair, or other claims regarding the machine unless ISHIDA's analysis confirms that the machines were properly handled, stored, installed, and maintained and not subject to contamination, abuse, misuse, or inappropriate modification or repair.

Change in Specifications

Machine specifications and accessories may be changed at any time due to improvements or other reasons. Consult with your ISHIDA representative at any time to confirm the actual specifications of the purchased machine.





Errors and Omissions

The information in this manual has been carefully checked and is believed to be accurate; however, no responsibility is assumed for clerical, typographical or proofreading errors, or omissions.

Precautions

Precaution symbols

This machine is manufactured for use according to proper procedures by a qualified person and only for the purposes described in this manual. The following conventions are used to indicate and classify precautions depending on the level of danger, or seriousness of potential injury. Always heed the information provided in this manual. Failure to heed precautions can result in personal injury or property damage.

 DANGER!	Indicates an imminently hazardous situation which, if not avoided, is likely to result in serious injury or may result in death.
 WARNING	Indicates a potentially hazardous situation which, if not avoided, will result in minor or moderate injury, or may result in serious injury or death.
 CAUTION	Indicates a potentially hazardous situation, which, if not avoided, may result in minor or moderate injury or in property damage.
Note:	Indicates information that needs to be noted or emphasized.
 INFORMATION	Indicates reference information when performing an operation.
 REFERENCE	Indicates the reference page related to performance of an operation.

Precautions for handling

WARNING

- **Do not allow water or any liquids to come into contact with the machine.**

Doing so may result in fire or cause the machine to break down.



- **Do not drop or apply a strong shock to the machine.**

Doing so may cause the machine to break down.



- **Do not disassemble, modify, or attempt to repair the machine.**

Doing so may damage the original safety functions.



- **Do not hold the connector cover when carrying the machine.**
Dropping the machine may result in injury or cause the machine to break down.
- **Do not hold the operation panel or weigh platter when carrying the machine.**
Doing so may cause the operation panel or the platter to break down.
- **Do not hold the customer display the when carrying the pole type machine.**
Dropping the machine may result in injury or cause the machine to break down.
- **Do not drop the cassette.**
Dropping the cassette may result in injury or cause the cassette to break down.
- **Handle with care when removing or inserting the cassette.**
Careless cassette handling may result in injury or cause the cassette to break down.
- **Do not press the touch panel with an edged thing.**
Doing so may scratch the panel and cause the machine to break down.
- **Do not dispose of batteries with normal household waste. Please obey your local regulations when disposing of used batteries.**

Precautions when using cleaning fluids

CAUTION

Use a soft cloth and a neutral detergent to clean the machine.
Do not use thinner, benzene, etc. Doing so may damage the original safety functions.
For some parts, use cleaning fluid (isopropyl alcohol).



CAUTION

- Do not use cleaning fluid near fire as the fluid is flammable.
- Do not use cleaning fluid in a poorly ventilated area. Always provide adequate ventilation when cleaning.

Take the following actions in the event of an accident:

If the fluid gets in your eye

- Immediately wash your eye(s) with water for at least 15 minutes, and consult your doctor.
- If you wear contact lenses, remove and wash them.

If the fluid comes into contact with your skin

- Immediately rinse the area of contact with water, and then wash with soap.
- If you notice any skin abnormalities at the area of contact, or if any pain persists, consult your doctor.

If the fumes of the fluid are inhaled

- Immediately move the victim to an area where fresh air is available, and have the victim lie down and keep warm.
- If breathing becomes difficult or stops, provide artificial respiration and seek medical attention immediately.

If the fluid is swallowed

- Do not try to induce vomiting.
- Do not give the victim anything to drink, and do not rinse the mouth.
- If vomiting occurs naturally, have the victim lean forward to reduce risk of aspiration.
- Keep the victim warm and seek medical attention.

Precautions for installation

WARNING

Do not install the machine in the following types of places:

- Places subject to high temperatures or high humidity.
- Places exposed to direct sunlight.
- Places where water or other liquids are easily spilled on the machine.

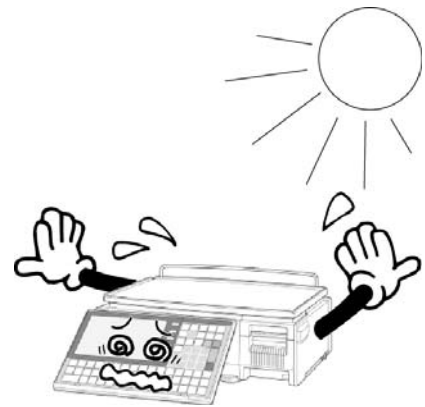

- Places subject to excessive vibration or unstable foundations.
- Places exposed to direct cold air from air conditioners or refrigerators.
- Places where the floor or foundation is unstable.



- Places subject to a lot of dust or dirt.
- Places with large voltage fluctuations.



Table of contents

Revision History.....	i
Notices	iii
Important notice.....	iii
Limitations of Liability.....	iii
Change in Specifications.....	iii
Errors and Omissions.....	iii
Precautions	iv
Precaution symbols.....	iv
Precautions for handling.....	v
Precautions when using cleaning fluids.....	vi
Precautions for installation.....	vii
Table of contents.....	viii
Chapter 1 Overview.....	1-1
1.1 External dimensions.....	1-1
1.1.1 Bench type.....	1-1
1.1.2 Pole type.....	1-3
1.1.3 Self-service type.....	1-5
1.1.4 Elevated type.....	1-6
1.2 Specifications.....	1-8
1.2.1 Weighing unit.....	1-8
1.2.2 Operator/ Customer unit.....	1-8
1.2.3 Printer unit.....	1-8
1.2.4 Others.....	1-8
1.2.5 Options.....	1-9
1.3 Installation.....	1-10
1.3.1 Power supply.....	1-10
Chapter 2 Assembly drawings.....	2-1
 NOTE Refer to SC216106 at the beginning.....	2-1
2.1 Bench type.....	2-1
2.1.1 Exploded view.....	2-1
2.1.2 Parts list.....	2-2
2.2 Pole type.....	2-3
2.2.1 Exploded view.....	2-3
2.2.2 Parts list.....	2-4
2.3 Elevated single printer type.....	2-5
2.3.1 Exploded view.....	2-5
2.3.2 Parts list.....	2-6

2.4	Elevated dual printer type.....	2-8
2.4.1	Exploded view.....	2-8
2.4.2	Parts list.....	2-9
Chapter 3	Machine disassembly	3-1
3.1	Bench type	3-1
3.1.1	Upper case	3-1
3.1.2	Weigh platter holder.....	3-2
3.1.3	Main board.....	3-3
3.1.4	Operation panel	3-4
3.1.5	Customer display	3-6
3.1.6	Label sensor	3-8
3.1.7	Peel Sensor	3-8
3.1.8	Thermal head unit.....	3-9
3.1.9	Load cell & A/D board.....	3-11
3.1.10	Power supply unit	3-12
3.1.11	Motor unit.....	3-13
3.1.12	Wireless LAN unit	3-14
3.2	Pole type.....	3-15
3.2.1	Pole unit.....	3-15
3.2.2	Customer display unit	3-16
3.3	Self-service type	3-17
3.3.1	Self-service panel unit	3-17
3.3.2	Panel control board.....	3-19
3.4	Elevated type	3-20
3.4.1	Operation panel unit	3-20
3.4.2	Customer display unit	3-22
3.4.3	Elevated unit.....	3-23
Chapter 4	Mechanical adjustment.....	4-1
4.1	Four corner limit space.....	4-1
4.2	Print position	4-3
4.3	Thermal head position	4-4
Chapter 5	Electrical signals.....	5-1
5.1	Main board (PK-260).....	5-1
5.1.1	XJ16	5-1
5.1.2	XJ20	5-1
5.1.3	XJ2	5-2
5.1.4	XJ17	5-2
5.1.5	XJ6	5-3
5.1.6	XJ1	5-3
5.1.7	XJ10	5-3
5.1.8	XJ7	5-3
5.1.9	XJ22	5-3
5.1.10	XJ8	5-4

5.1.11	XJ14	5-4
5.1.12	XJ13	5-4
5.1.13	XJ15	5-5
5.1.14	XJ4	5-5
5.1.15	XJ11	5-5
5.1.16	XJ12	5-5
5.1.17	XJ3	5-6
5.2	Key/ LCD board (PK-261).....	5-7
5.2.1	XJ1	5-7
5.2.2	XJ2	5-7
5.2.3	XJ3	5-7
5.2.4	XJ4	5-8
5.2.5	XJ5	5-8
5.2.6	XJ6	5-8
5.2.7	XJ8	5-8
5.2.8	XJ9	5-8
5.2.9	XJ10, 11	5-9
5.3	LCD board (PK-263).....	5-10
5.3.1	XJ1	5-10
5.3.2	XJ2	5-10
5.3.3	XJ3	5-10
5.3.4	XJ4	5-11
5.4	Wireless LAN board (PK-265).....	5-12
5.4.1	XJ1	5-12
5.4.2	XJ2	5-12
5.5	Self-service master board (PK-266).....	5-13
5.5.1	XJ1	5-13
5.5.2	XJ2	5-13
5.5.3	XJ3/ XJ4	5-13
5.5.4	XJ5	5-13
5.5.5	XJ6/ XJ7	5-14
5.6	Self-service master board (PK-267).....	5-15
5.6.1	XJ1	5-15
5.6.2	XJ2	5-15
5.7	Thermal board (PK-268).....	5-16
5.7.1	XJ2	5-16
5.7.2	XJ4	5-16
5.7.3	XJ5	5-17
5.7.4	XJ6	5-17
5.7.5	XJ1	5-17
5.8	Thermal connector board (PK-268).....	5-18
5.8.1	XJ1	5-18
5.8.2	XJ2	5-18
5.8.3	XJ2	5-19
5.9	Scale board (PK-999).....	5-20
5.9.1	XJ2	5-20

Chapter 6	SETUP mode	6-1
6.1	SETUP mode entry	6-1
6.2	LABEL setting	6-4
6.3	LABEL FORMAT setting	6-7
6.4	BARCODE setting.....	6-8
6.5	CUSTOM BARCODE setting	6-9
6.6	MENU TITLE setting	6-12
6.7	OPERATION SETTING	6-15
6.8	ERROR PROCESS setting.....	6-16
6.9	ERROR LOG display	6-17
6.10	TRACEABILITY setting.....	6-18
6.11	DUAL CURRENCY setting	6-19
6.12	PRICE ROUNDING setting.....	6-22
6.13	FREQUENT SHOPPER setting	6-23
6.14	DATA DISTRIBUTION setting.....	6-25
6.15	COUNTRY setting	6-29
6.16	FILE SAVE / LOAD	6-33
Chapter 7	ADJUSTment mode	7-1
7.1	ADJUSTment mode entry	7-1
7.2	KEY CHECK	7-3
7.3	FIRMWARE DETAILS	7-4
7.4	MEMORY CLEAR	7-5
7.5	PRINTER adjustment.....	7-7
7.6	CALIBRATION.....	7-15
7.7	DOWNLOADing.....	7-19
7.8	OPTION CHECK	7-23
7.9	DISPLAY CAPTURE.....	7-25
7.10	MODEL setting.....	7-26
Chapter 8	Error screens	8-1
8.1	ERROR ID Nos. 105 to 116.....	8-1
8.2	ERROR ID Nos. 202 to 295.....	8-2
8.3	ERROR ID Nos. 312 to 396.....	8-5
8.4	ERROR ID Nos. 703 to 715.....	8-7
8.5	ERROR ID Nos. 1601 to 1624.....	8-9
8.6	ERROR ID Nos. 1801 to 1824.....	8-10
8.7	ERROR ID No. 2001	8-11
8.8	ERROR ID Nos. 9608 to 9690.....	8-12

Chapter 9	Appendix	9-1
9.1	Text editing	9-1
9.1.1	Operation panel and key functions	9-1
9.1.2	Normal character registration.....	9-3
9.1.3	Special character registration	9-6
9.1.4	Line deletion	9-8
9.1.5	Character deletion	9-9
9.1.6	Character backspacing	9-11
9.2	Block diagram	9-13
9.2.1	Bench/Pole type.....	9-13
9.2.2	Elevated type	9-14

Information

Changing Power Supply Unit along with Changing CE Declaration

Document No:	SC216106	Category	UNI-3, 5, 7, and 9H
Issue date:	27 April 2021	Approved:	T. Ando
Checked:	N. Izumi	By:	N. Odahara

Technical Reports are issued for our agencies/distributors. Please handle carefully not to pass them directly to customers.

[Summary]

To support the change of CE declaration, the power supply unit used for UNI-3, UNI-5, UNI-7, and UNI-9H with EU specification will be changed. The following two points are changed along with changing the power supply unit.

- * Changing Harness
- * Adding a bracket to mount Power supply unit

Replacing the power supply unit in service on-site with the new one is NOT required.

Arranging spare parts for the previous power supply unit in service is available.

IP-AI and UNI-9 has already supported the change of CE Declaration.

[Details]

<UNI-3>

	Previous parts	New parts
Power supply	000-900-1682-07 CWS100-24:	00-000-1838-00 LRS-150-24 M
Bracket	None	300-000-1863-00 BRACKET
Harness	000-900-2841-06	300-000-1720-00 HARNESS C3 POWER
Harness	000-900-0286-11	300-000-1721-00 HARNESS S2 DC24 240MM

UNI-3 has been equipped with the new parts from the following Serial No.
100528311 - 100528330 (Shipped at the end of February 2021)

<UNI-5, 7, and 9H>

	Previous parts	New parts
Power supply	000-079-1225-04 ZWS150PAF-24/J	400-000-5223-00 ZWS150BP-24
Bracket	None	400-000-5224-00 BRACKET x 2pcs
Harness	000-089-5634-08	400-000-5267-00 HARNESS S2 24V DC POWER (For Hanging specification, harness is NOT changed)

UNI5, 7, and 9H will be equipped with the new parts from the following Serial No.
100527461 – 100527467 (Shipped in May 2021)

Attachment: SC216106

How to distinguish the previous/new power supply unit

<UNI-3>

Previous power supply CWS100-24:



<UNI-3>

New power supply LRS-150-24 MW (mounted)

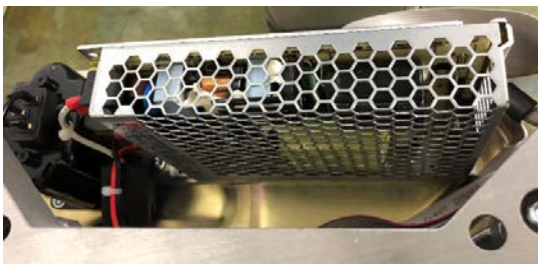

New power supply LRS-150-24 MW and harness



Additional bracket



<UNI5, 7, and 9H >

Previous power supply ZWS150PAF-24/J



<UNI5, 7, and 9H >

New power supply ZWS150BP-24 (mounted)

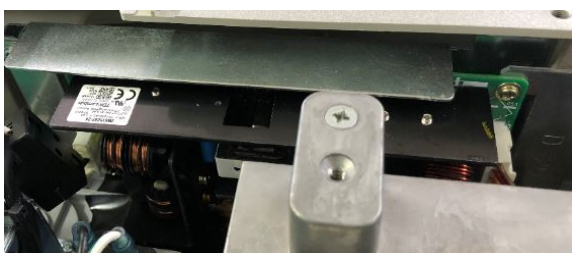

Additional bracket and harness

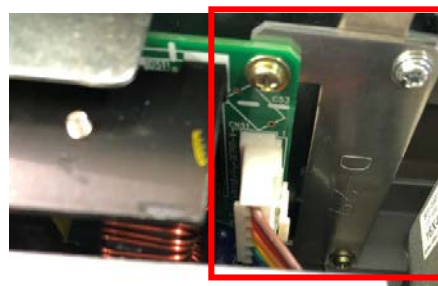

Information			
Item codes of operation panel's LCD unit are changed (Target: USA, Canada, and Taiwan)			
Document No:	SC236115	Category	UNI-5, 7
Issue date:	20 March 2023	Approved:	A. Hattori
Checked:	Y. Fujiwara	By:	N. Izumi

Technical Reports are issued for our agencies/distributors. Please handle carefully not to pass them directly to customers.

[Contents]

Due to a shortage of parts supply, it is difficult to maintain a stable supply of LCD manufactured by Innolux, which are used in the operator display and customer display. For "USA, Canada, and Taiwan", the latest item codes of the parts conforming to local standards are listed below. To maintain a stable supply of the maintenance parts, please order parts with the latest item code after receipt of this Technical Report.

For countries (other than USA, Canada, and Taiwan) not affected by local standards (such as UL Standards), see SC236116.

[Details]

<List of the latest item codes> Destination: USA, Canada, Taiwan

Target Machine	Former Item Code	Latest Item Code	Item Name	Note
UNI-5 UNI-7	000-089-5623-16	000-089-5623-18	LCD	For ALL
UNI-5 UNI-7	000-089-6859-04	400-000-5528-00	LCD PANEL TOUCH	For ALL
UNI-5 UNI-7	000-089-6678-05	No change	FRONT LCD ASSY	For ALL
UNI-5	000-089-6839-08	No change	CONTROLL ASSY	For ALL
UNI-7	400-000-0429-00	No change	CONTROLL ASSY	For ALL
UNI-5	400-000-1788-00	No change	CONTROL ASSY UNIT	For CANADA *
UNI-5	400-000-2109-00	No change	CONTROL ASSY UNIT	For NORTH AMERICA *
UNI-7	000-089-8105-05	No change	CONTROL ASSY UNIT	For MEXICO *
UNI-7	400-000-0430-00	No change	CONTROL ASSY UNIT	For CANADA *

* CONTROL ASSY UNIT is a unit of which following four kinds of sheets are attached by destination.

SHEET KEY BOARD_SETTING / SHEET KEY BOARD_PLU
COVER KEY BOARD / NAME PLATE SPEC



<Reference document Exploded view>

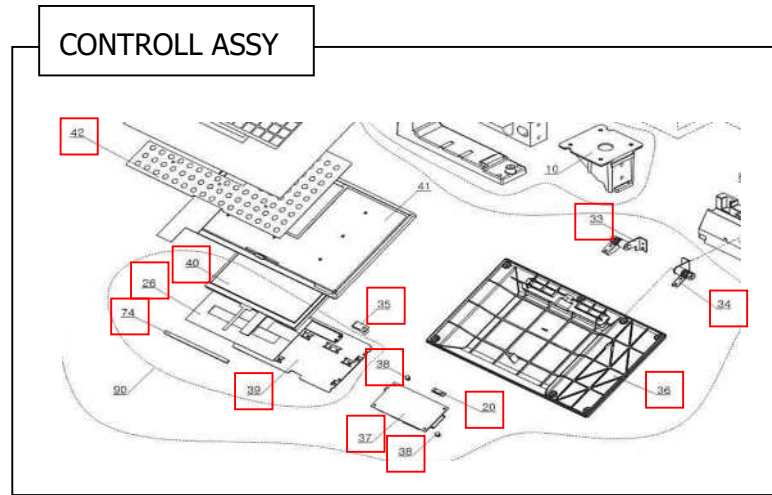
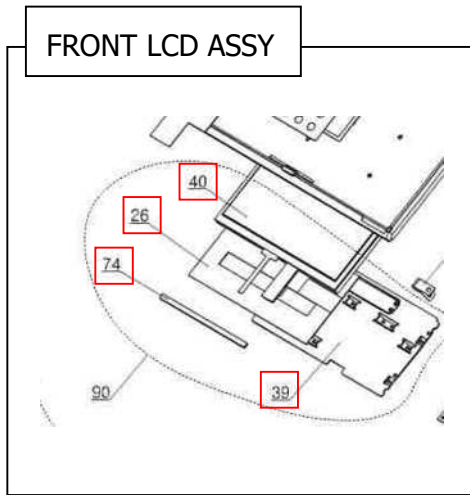

UNI-5 sample image



For any questions about this technical report, please contact us: sc_tec@ishida.co.jp

Information			
Item codes of operation panel's LCD unit are changed (Target: Not UL Standards)			
Document No:	SC236116	Category	UNI-5, 7
Issue date:	20 March 2023	Approved:	A. Hattori
Checked:	Y. Fujiwara	By:	N. Izumi

Technical Reports are issued for our agencies/distributors. Please handle carefully not to pass them directly to customers.

[Contents]

Due to a shortage of parts supply, it is difficult to maintain a stable supply of LCD manufactured by Innolux, which are used in the operator display and customer display. At the time of manufacture, the LCD is changed to alternative LCD for the machines shipped to countries not affected by local standards (UL Standards) (other than USA, Canada, and Taiwan).

To maintain a stable supply of the maintenance parts, please order parts with the latest item code after receipt of this Technical Report.

For countries affected by local standards (USA, Canada, Taiwan), see SC236115.

[Details]

<Changes due to changes in LCD parts>

There is no change in software, mechanical parts, and electrical parts. Parts can be replaced in the same way as current maintenance parts.

List of the machines switched to alternative parts at the time of manufacture (other than USA, Canada, Taiwan)

Model name	Destination	Weighing capacity	Serial No.	Date of shipment
UNI-5 BENCH	AUSTRALIA	30KG	100641617	12/20
UNI-5 BENCH RECEIPT	AUSTRALIA	15KG	100641618 - 100641628	1/3
UNI-5 POLE RECEIPT	AUSTRALIA	15KG	100641629 - 100641638	1/31
UNI-5 EV1 RECEIPT	AUSTRALIA	15KG	100641639	12/20
UNI-5 EV1 RECEIPT	AUSTRALIA	15KG	100641640 - 100641642	12/20
UNI-7 EV1	S.AMERICA	15KG	100641673 - 100641681	1/17
UNI-7 HANGING	S.AMERICA	15KG	100641682 - 100641701	—
UNI-7 TYPE RP	EURO	DUAL RAGE	100641702 - 100641721	1/13
UNI-7 HANGING	S.AMERICA	15KG	100641722 - 100641731	—
UNI-7 POLE	EURO	15KG	100641732 - 100641737	1/16

<List of the latest item codes> Destination: other than USA, Canada, Taiwan

Target Machine	Former Item Code	Latest Item Code	Item Name
UNI-5 UNI-7	000-089-5623-16	000-148-3655-10	LCD
UNI-5 UNI-7	000-089-6859-04	400-000-5646-00	LCD PANEL TOUCH
UNI-5 UNI-7	000-089-6678-05	400-000-6590-00	FRONT LCD ASSY
UNI-5	000-089-6839-08	400-000-6335-00	CONTROLL ASSY
UNI-7	400-000-0429-00	400-000-6353-00	CONTROLL ASSY

<Reference document Exploded view>

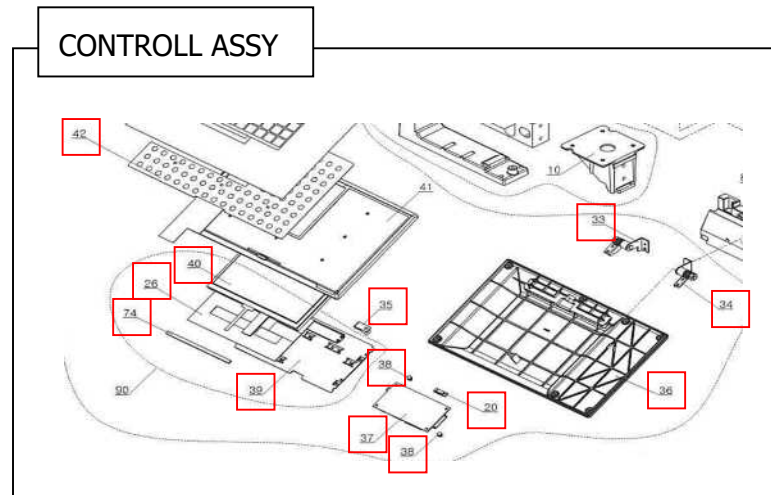
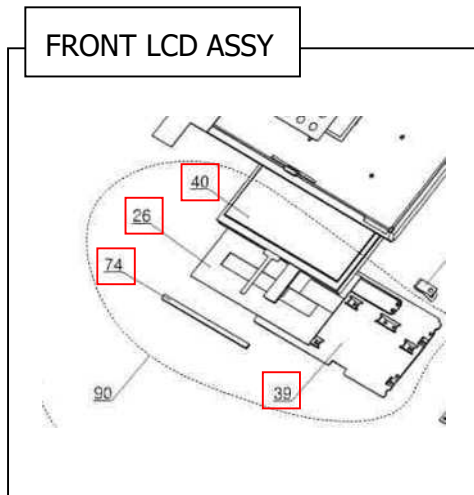

UNI-5 sample image



For any questions about this technical report, please contact us: sc_tec@ishida.co.jp

Chapter 1 Overview

1.1 External dimensions

1.1.1 Bench type

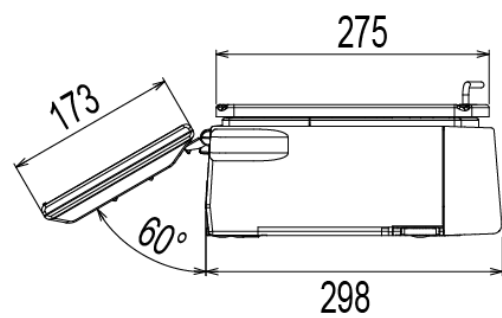
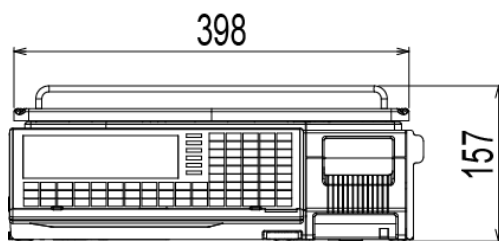
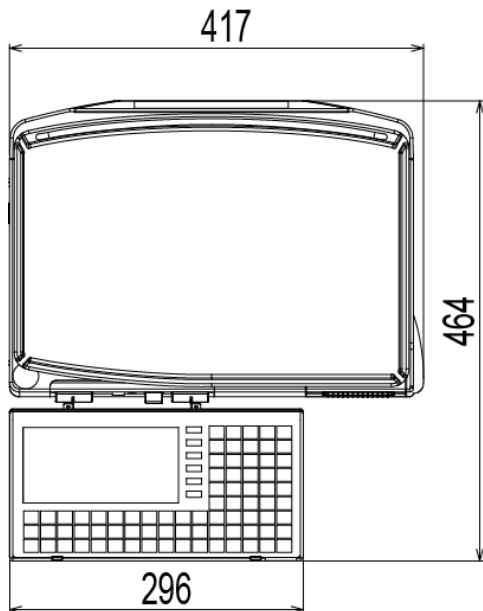

Unit: mm

NOTE

- 1. Guide platter is option.

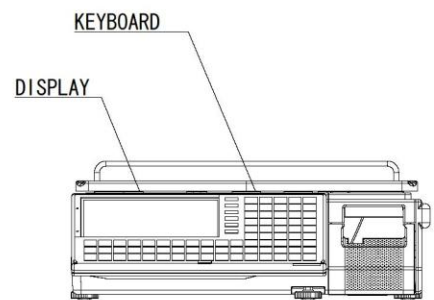
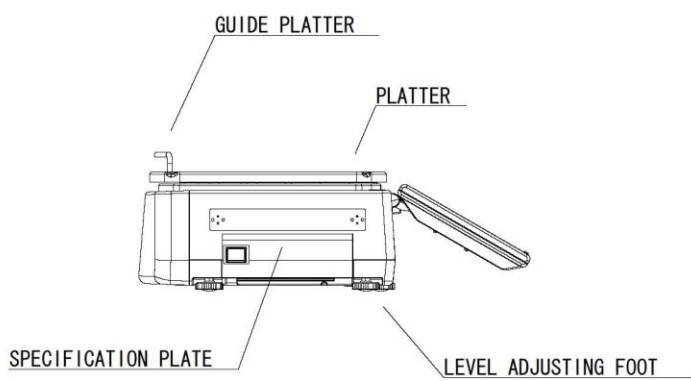
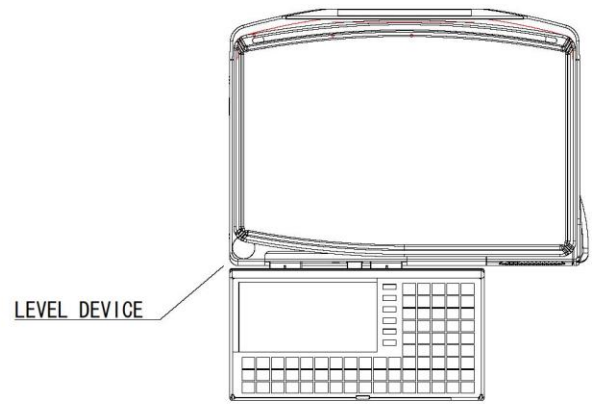

1.1.2 Pole type

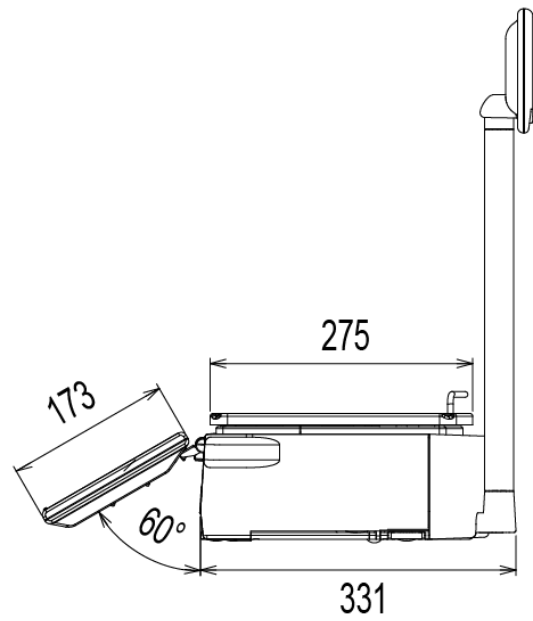
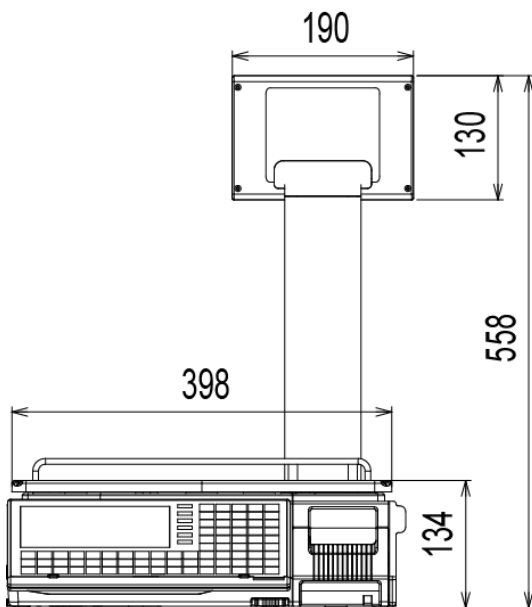
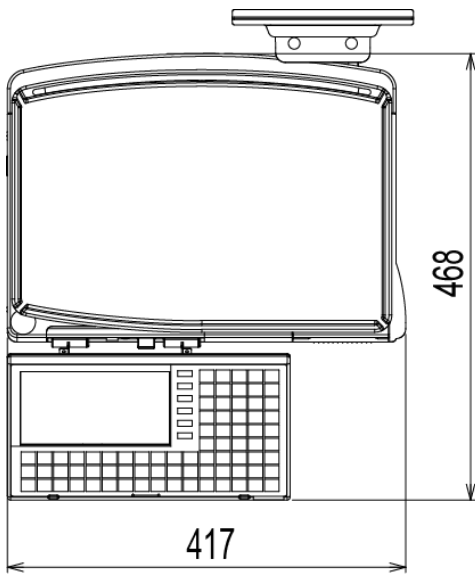

Unit: mm

NOTE

1. Guide platter is Option.
2. The display panel may be installed to turn operator's side for the self-service mode.

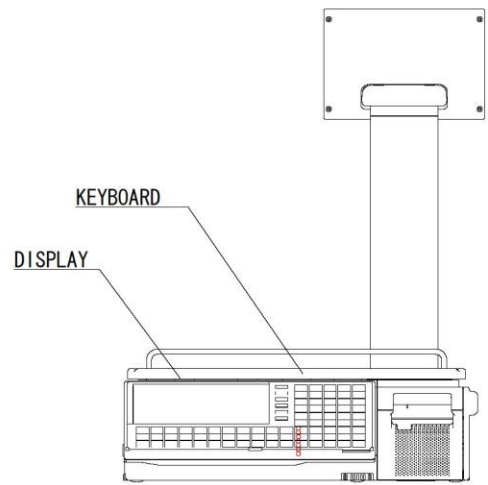
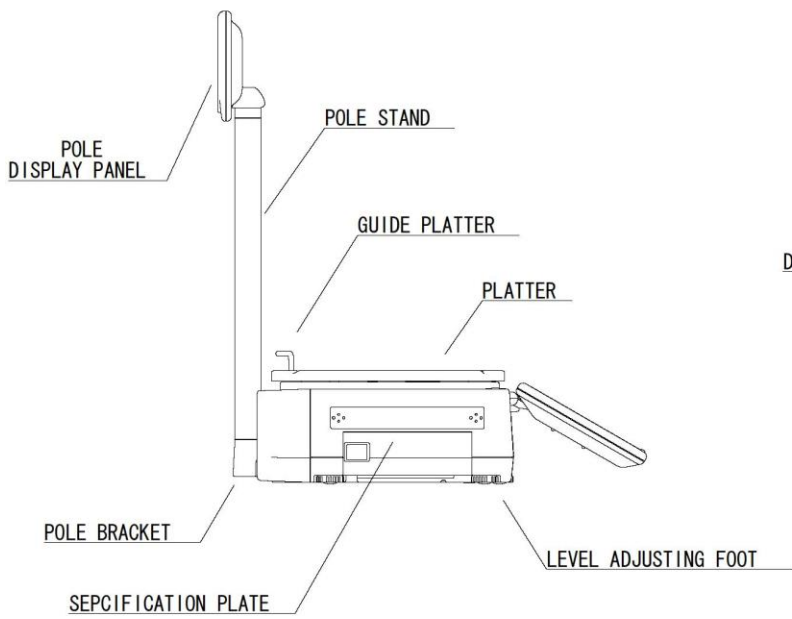
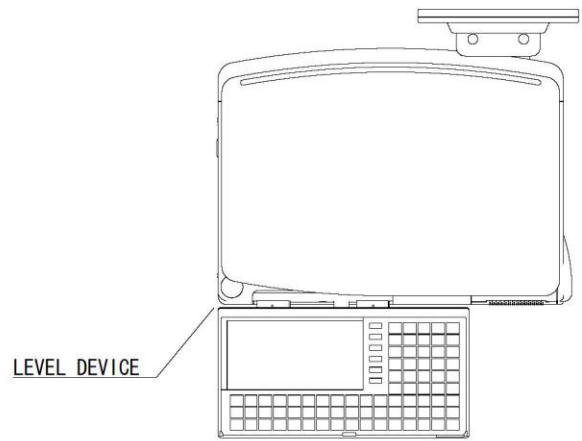

1.1.3 Self-service type

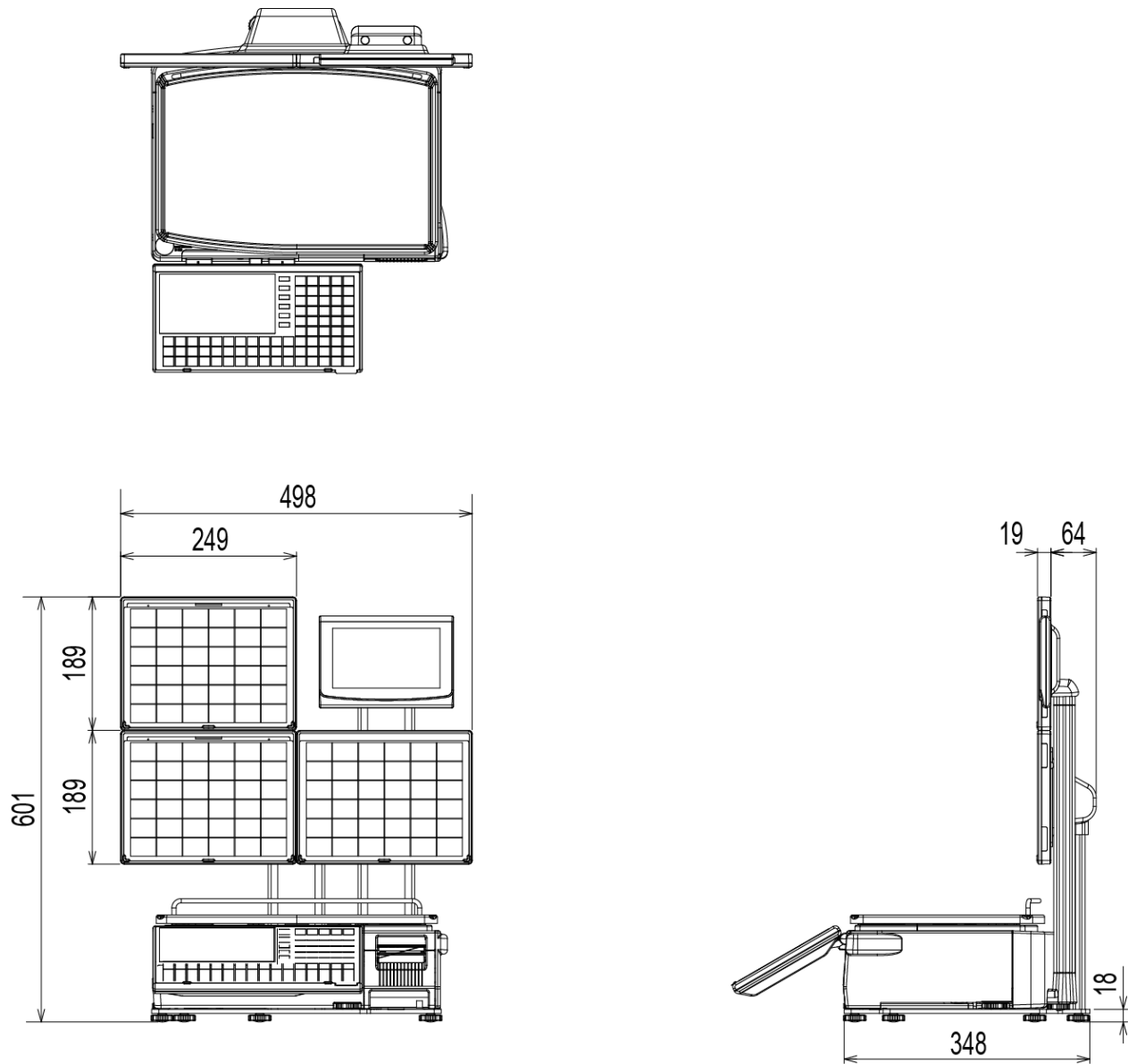

Unit: mm

1.1.4 Elevated type

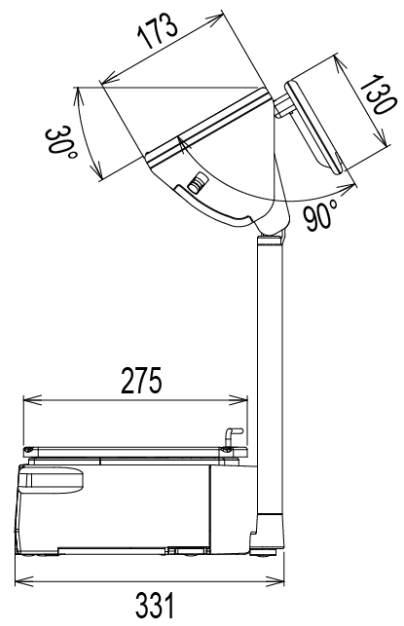
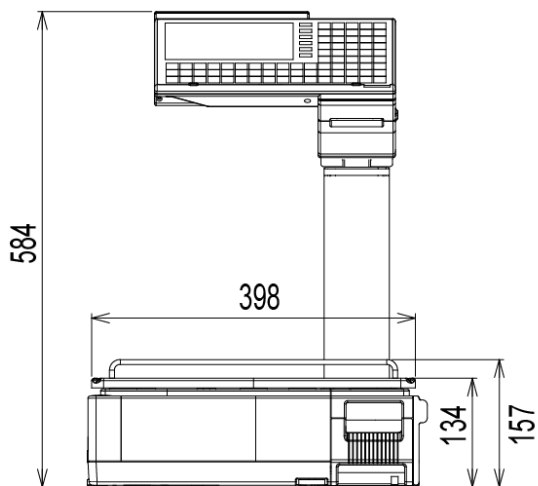
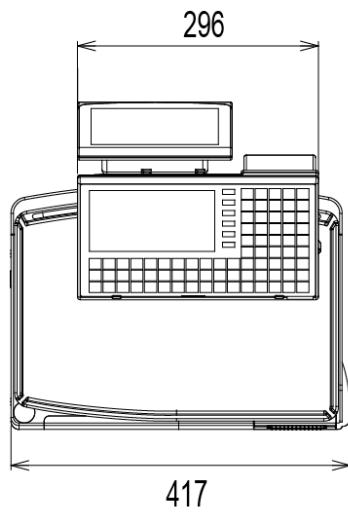

Unit: mm

NOTE

- 1. Guide Platter is Option.

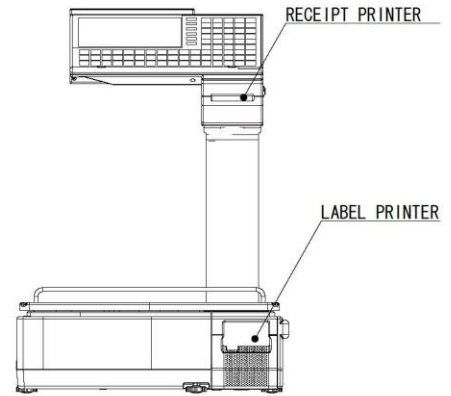
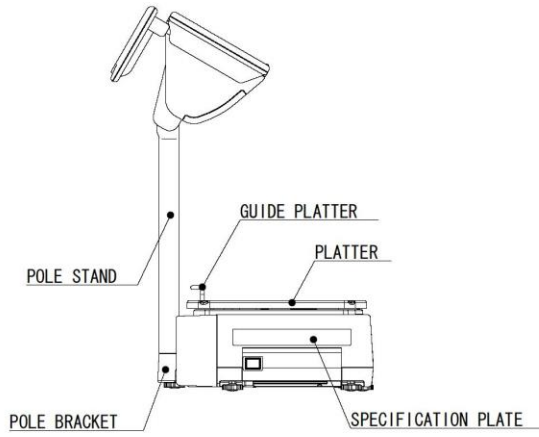
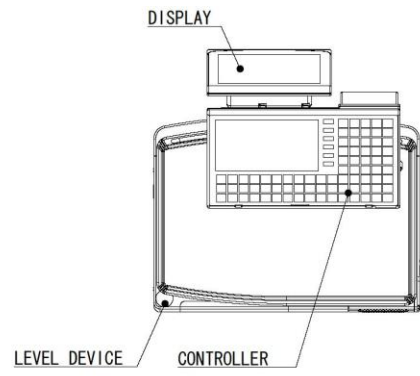

1.2 Specifications

1.2.1 Weighing unit

Items	Descriptions
Weighting accuracy	1/3000
Weighting capacity	15 kg: 0 to 6/ 0.002 kg, 6 to 15/ 0.005 kg
Scale interval	30 lb: 0 to 15/ 0.005 lb, 15 to 30/ 0.01 lb

1.2.2 Operator/ Customer unit

Item	Description
Display	7.0 inch color liquid crystal with back light, 480 x 234 dots

1.2.3 Printer unit

Items	Descriptions
Printing method	Direct thermal method
Thermal head	2 inches (448 dots) and 8 dots/mm
Printing speed	100 mm/sec, 120 mm/sec It may not be able to be recognized depending on the quality of the label.
Printing effective size	56 mm
Label size	Label width: 30 to 60 mm Label length: 20 to 150 mm

1.2.4 Others

Items	Descriptions
Power supply	100 to 240 V AC, 50/ 60 Hz
Power consumption	1.0 A/ 0.5 A
Use conditions	Temperature: -5 to 35°C Humidity: 30 to 85%, Non condensing
Input/ Output	LAN: 1 channel USB: 1 channel CF: 1 channel Drawer: 2 channels
Program store medium	Flash ROM (32M bytes)

1.2.5 Options

- Wi-fi
- Barcode scanner

1.3 Installation

1.3.1 Power supply



It is strongly advised that the following safety measures must be observed to ensure the safe operation of the machine:

- **Read precaution instructions described in this manual before connecting the power plug into the outlet.**
- **Always use a power supply with rated voltage. Never connect the machine power input with an AC power supply exceeding the rated voltage. To avoid any potential electrical shock, ensure that the protective ground wire is connected to the main grounding provision.**
Using the machine outside of the rated voltage may result in machine failure or danger such as electric shock.
- **Prepare a dedicated power source.**
A power supply that generates voltage variation may cause a malfunction.
- **Do not stand on the power cable, and do not place anything heavy on the cable.**
Doing so may damage the cable, resulting in accident or trouble.
- **Disconnect power supply before servicing.**
To ensure your personal safety, disconnect the power supply before servicing.
- **Take precaution against residual electrical charge hazard.**
Capacitors inside the machine may still hold an electrical charge even after power is disconnected.
- **Do not remove covers or enclosures.**
To avoid personal injury and shock, do not open or remove any covers or enclosures of the machine unless specified in the manual.
- **Do not perform unspecified maintenance.**
For your personal safety, do not perform any maintenance procedures which are not specified in the manual.

Chapter 2 Assembly drawings

NOTE Refer to SC216106 at the beginning.

2.1 Bench type

2.1.1 Exploded view

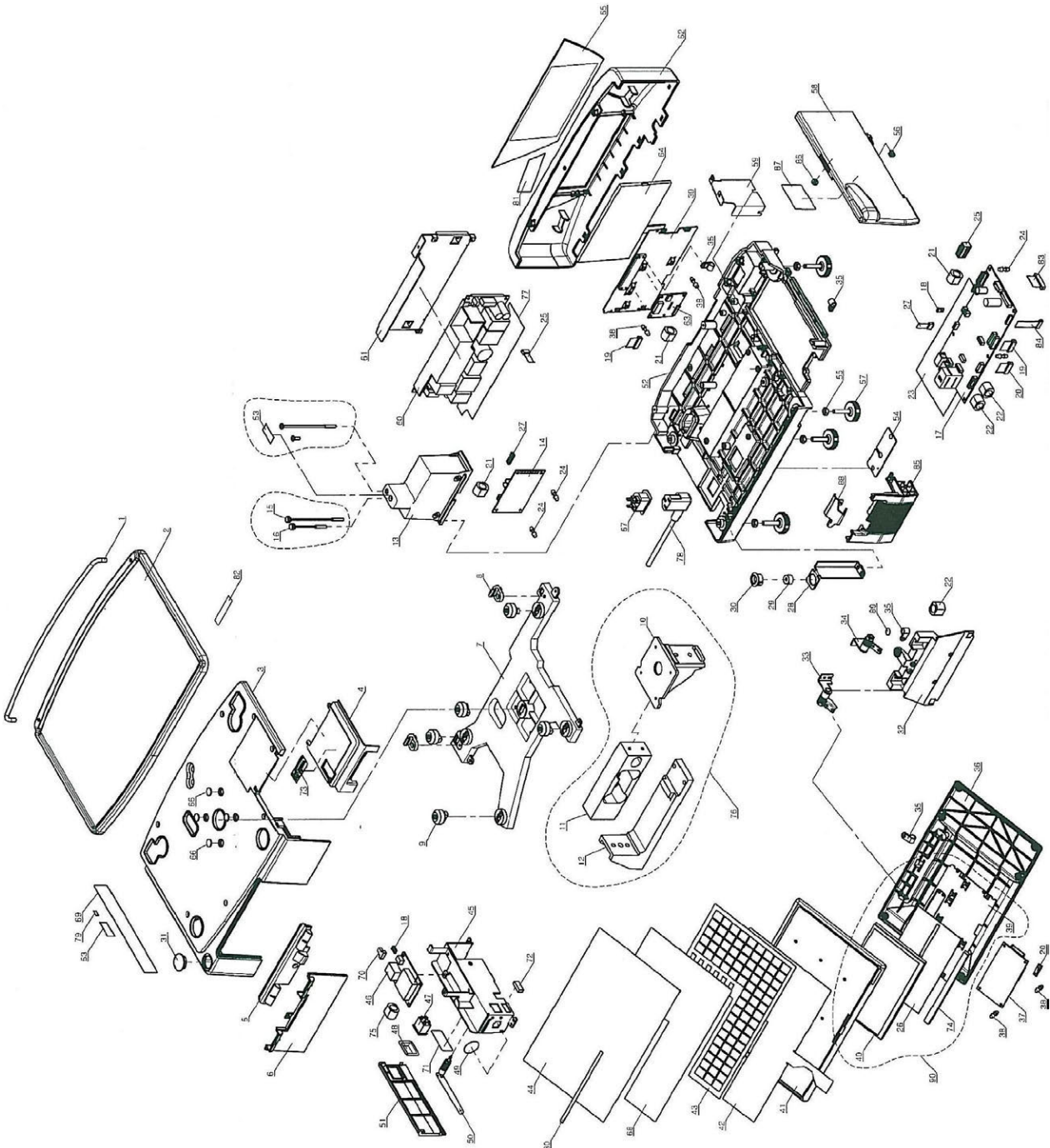

2.1.2 Parts list

NO.	PART NAME	Q'TY	NO.	PART NAME	Q'TY
1	GUIDE PLATE	1	45	BRACKET CONNECTOR ASSY	1
2	PLATTER ASSY	1	46	PWB PK-265A	1
3	CASE MAIN UPPER	1	47	HARNESS C4 SWITCH ASSY	1
4	COVER PRINTER UPPER	1	48	COVER SWITCH	1
5	COVER HINGE UPPER	1	49	STICKER 'SEAL'	2
6	COVER HINGE LOWER	1	50	ANTENNA	1
7	PLATTER SUPPORT	1	51	COVER BRACKET CONNECTOR	1
8	BLOCK B HINGE PLATTER	2	52	BASE	1
9	RUBBER PLATER SUPPOR	5	53	STICKER VOID	2
13	CASE A/D BOARD	1	54	PLATE B RS232C	1
14	PWB P-999B	1	56	BLOCK B HINGE SIDE COVER	1
15	SCREW 'SEAL' HEXA	1	57	FOOT ADJUST	4
16	SCREW 'SEAL' HEXA	1	58	COVER SIDE	1
17	PWB PK-270C	1	59	COVER HARNESS	1
18	HARNESS S2 5V POWER	1	60	POWER SUPPLY	1
19	HARNESS S2 REAR LCD	1	61	BRACKET POWER	1
20	HARNESS S2 FRONT LCD	1	62	CASE REAR COVER	1
21	FERRITE CORE	3	63	PWB PK-263A	1
22	FERRITE CORE	2	64	LCD	1
23	SHEET INSULATION	1	65	CASE REAR PANEL	1
24	ACCESSORY PWB GUIDE SPACE	2	66	CAP	4
25	HARNESS S2 24V DC POWER	1	67	HARNESS C2 POWER ASSY	1
26	SHEET DOUBLE TAPE	1	68	SHEET KEY BOARD-PLU	1
27	HARNESS C2 A/D	1	70	HARNESS S2 LAN	1
28	BRACKET LEVEL	1	71	STICKER LOCATION OUTPUT	1
29	LEVEL UNIT	1	72	GASKET 20mm	1
30	FRAME LEVEL	1	73	STICKER IMPORTANT	1
31	LEVEL LENS	1	74	GASKET 115mm	1
32	BRACKET HINGE	1	75	FERRITE CORE	1
33	HINGE L	1	76	LOADCELL ASSEMBLY	1
34	HINGE R	1	77	SHEET INSULATION POWER SUPPLY	1
35	EARTH CLAMP	4	78	POWER CORD	1
36	CASE REAR CONTROLL	1	79	STICKER 'M'	1
37	PWB PK-261A	1	83	HARNESS C2 HEAD	1
38	ACCESSORY PCB SUPPORT	4	84	HARNESS C3 SENSOR	1
39	BRACKET LCD	2	85	COVER PRINTER	1
40	LCD TOUCH	1	86	MAGNETIC	1
41	CASE FRONT CONTROLL	1	87	STICKER LABEL SETTING	1
42	KEY BOARD MEMBRANE	1	88	BRACKET LABEL PEEL	1
43	SHEET KEY BOARD-SETTING	1	89	PLATE A COVER	1
44	COVER KEY BOARD	1	90	FRONT LCD ASSY	1

2.2 Pole type

2.2.1 Exploded view

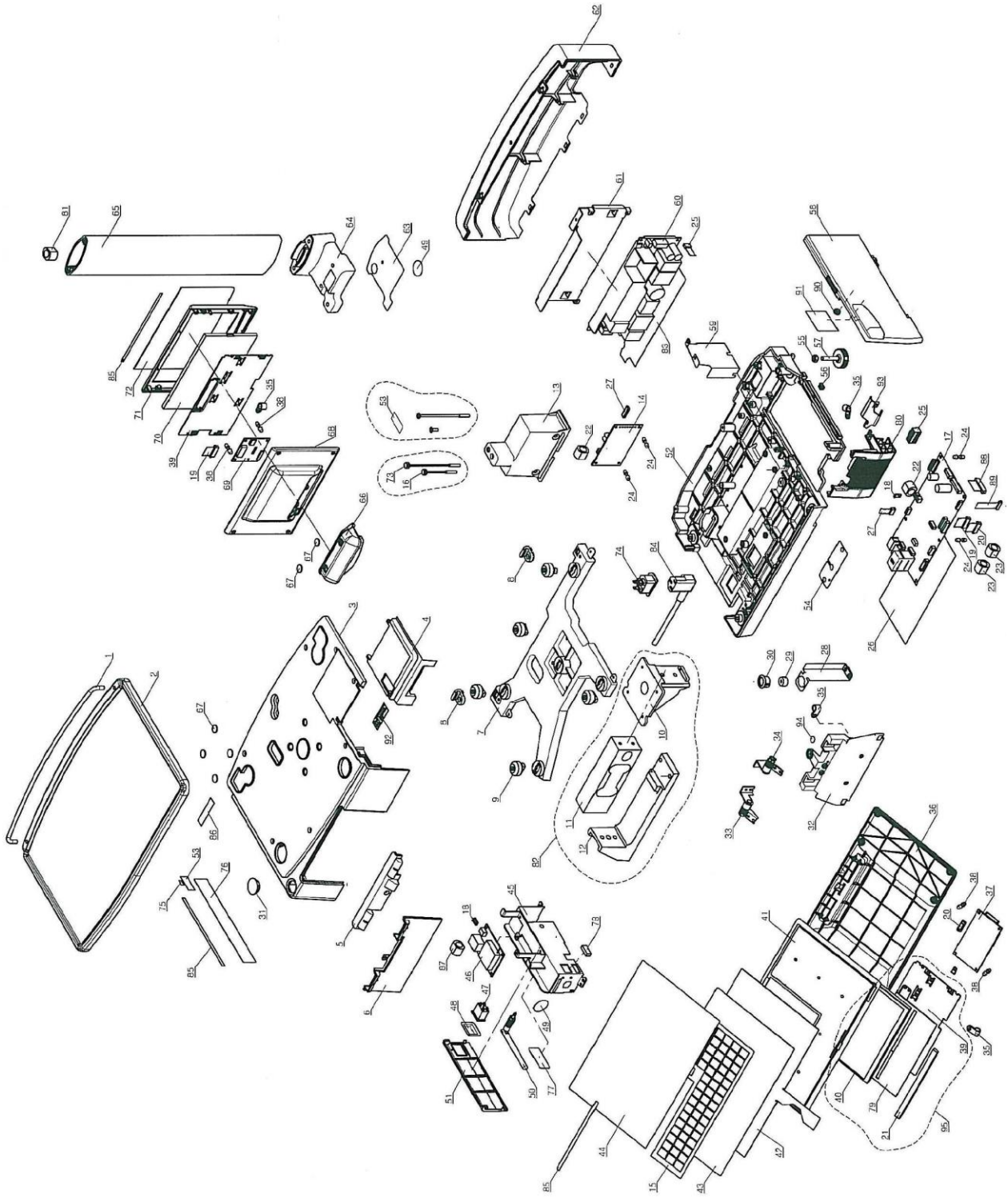

2.2.2 Parts list

NO.	PART NAME	Q'TY	NO.	PART NAME	Q'TY
1	GUIDE PLATTER	1	49	STICKER SEAL	3
2	PLATTER ASSY	1	50	ANTENNA	1
3	CASE MAIN UPPER	1	51	COVER BRACKET CONNECTOR	1
4	COVER PRINTER UPPER	1	52	BASE	1
5	COVER HINGE UPPER	1	53	STICKER VOID	2
6	COVER HINGE LOWER	1	54	PLATE B RS232C	1
7	PLATTER SUPPORT	1	56	BLOCK B HINGE SIDE COVER	1
8	BLOCK B HINGE PLATTER	2	57	FOOT ADJUST	4
9	RUBBER PLATTER SUPPORT	5	58	COVER SIDE	1
13	CASE A/D BOARD	1	59	COVER HARNESS	1
14	PWB P-999B	1	60	POWER SUPPLY	1
15	SHEET KEY BOARD-PLU	1	61	BRACKET POWER	1
16	SCREW SEAL HEXA	1	62	CASE REAR POLE	1
17	PWB PK-270C	1	63	PLATE B BRACKET POLE	1
18	HARNESS S2 5V POWER	1	64	BRACKET POLE STAND	1
19	HARNESS S2 REAR LCD(POLE)	1	65	POLE STAND	1
20	HARNESS S2 FRONT LCD	1	66	CASE LINK POLE	1
21	GASKET 115mm	1	67	CAP	6
22	FERRITE CORE	2	68	CASE REAR POLE DISPLAY	1
23	FERRITE CORE	2	69	PWB PK-263A	1
24	ACCESSORY PWB GUIDE SPACER	4	70	LCD	1
25	HARNESS S2 24V DC POWER	1	71	CASE FRONT POLE DISPLAY	1
26	SHEET INSULATION	1	72	SHEET DISPLAY PANEL	1
27	HARNESS C2 A/D	1	73	SCREW SEAL HEXA	1
28	BRACKET LEVEL	1	74	HARNESS C2 POWER ASSY	1
29	LEVEL UNIT	1	75	STICKER 'M'	1
30	FRAME LEVEL	1	77	STICKER LOCATION OUTPUT	1
31	LEVEL LENS	1	78	GASKET 20mm	1
32	BRACKET HINGE	1	79	SHEET DOUBLE TAPE	1
33	HINGE L	1	80	COVER CASSETTE	1
34	HINGE R	1	81	FERRITE CORE	1
35	EARTH CLAMP	4	82	LOADCELL ASSEMBLY	1
36	CASE REAR CONTROLL	1	83	SHEET INSULATION POWER SUPPLY	1
37	PWB PK-261A	1	84	POWER CORD	1
38	ACCESSORY PCB SUPPORT	4	85	NAME PLATE SPEC	2
39	BRACKET LCD	2	86	NAME PLATE SERIAL	1
40	LCD TOUCH	1	87	FERRITE CORE	1
41	CASE FRONT CONTROLL	1	88	HARNESS C2 HEAD	1
42	KEY BOARD MEMBRANE	1	89	HARNESS C3 SENSOR	1
43	SHEET KEY BOARD-SETTING	1	90	MAGENT	1
44	COVER KEY BOARD	1	91	STICKER LABEL SETTING	1
45	BRACKET CONNECTOR ASSY	1	92	STICKER IMPORTANT	1
46	PWB PK-265A	1	93	BRACKET LABEL PEEL	1
47	HARNESS C4 SWITCH ASSY	1	94	PLATE A COVER	1
48	COVER SWITCH	1	95	FRONT LCD ASSY	1

2.3 Elevated single printer type

2.3.1 Exploded view

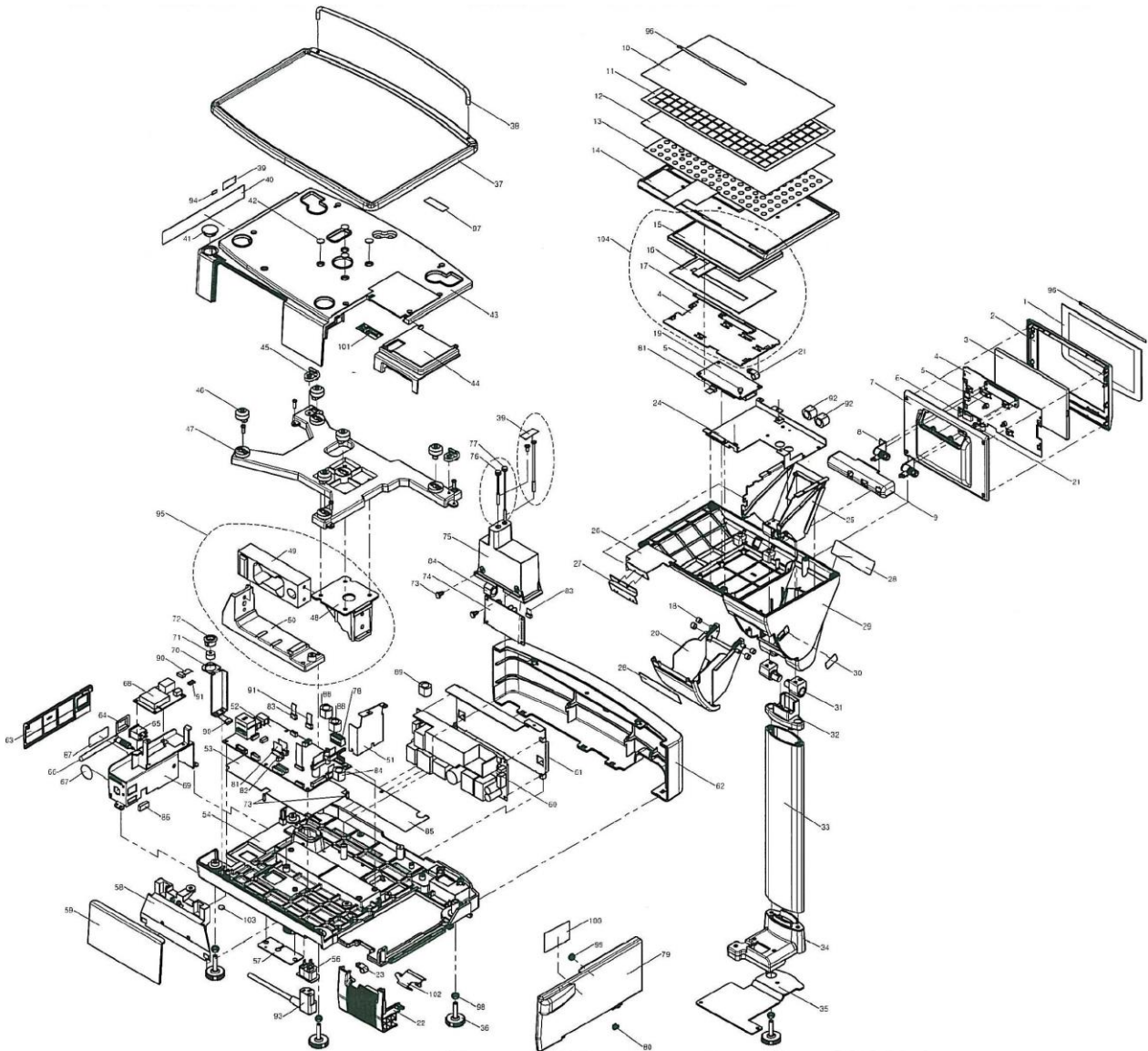

2.3.2 Parts list

NO.	PART NAME	Q'TY	NO.	PART NAME	Q'TY
1	SHEET DISPLAY PANEL	1	54	BASE	1
2	CASE FRONT POLE DISPLAY	1	56	HARNESS C2 POWER ASSY	1
3	LCD	1	57	PLATE B RS232C	1
4	BRACKET LCD	2	58	BRACKET HINGE	1
5	ACCESSORY PCB SUPPORT	4	59	COVER FRONT ELEVATE	1
6	PWB PK-263A	1	60	POWER SUPPLY	1
7	CASE REAR POLE DISPLAY	1	61	BRACKET POWER	1
8	HINGE R	2	62	CASE REAR POLE DISPLAY	1
9	COVER JOINT REAR	1	63	COVER BRACKET CONNECTOR	1
10	COVER KEY BOARD	1	64	COVER SWITCH	1
11	SHEET KEY BOARD-PLU	1	65	HARNESS C4 SWITCH ASSY	1
12	SHEET KEY BOARD-SETTING	1	66	ANTENNA	1
13	KEY BOARD MEMBRANE	1	67	STICKER SEAL	2
14	CASE FRONT CONTROLL	1	68	PWB PK-265A	1
15	LCD TOUCH	1	69	BRACKET CONNECTOR ASSY	1
16	SHEET DOUBLE TAPE	1	70	BRACKET LEVEL	1
17	GASKET 115mm	1	71	LEVEL UNIT	1
18	COLLAR SPACER	4	72	FRAME LEVEL	1
19	PWB PK-261A	1	73	ACCESSORY PWB GUIDE SPACER	4
20	CASE PRINTER	1	74	PWB P-999B	1
21	EARTH CLAMP	2	75	CASE A/D BOARD	1
22	COVER CASSETTE	1	76	SCREW SEAL HEXA	1
23	EARTH CLAMP	1	77	SCREW SEAL HEXA	1
24	FRAME PRINTER UPPER	1	78	HARNESS S2 24V DC POWER	1
25	FRAME PRINTER	1	79	COVER SIDE	1
26	HOLDER COVER	1	80	BLOCK B HINGE SIDE COVER	1
27	BRACKET COVER	1	81	HARNESS S2 FRONTLCD(EV)	1
28	PANEL COVER	2	82	HARNESS S2 REAR LCD	1
29	CASE CONTROL REAR	1	83	HARNESS C2 A/D	1
30	PANEL BUTTON	1	84	FERRITE CORE	2
31	BUSH TORQUE	2	85	SHEET INSULATION POWER	1
32	BRACKET CONTROL	1	86	GASKET 20mm	1
33	POLE STAND	1	87	STICKER LOCATION OUTPUT	1
34	BRACKET POLE STAND	1	88	FERRITE CORE	2
35	PLATE B BRACKET POLE	1	89	FERRITE CORE	1
36	FOOT ADJUST	5	90	HARNESS S2 LAN	1
37	PLATTER ASSY	1	91	HARNESS S2 5V POWER	1
38	GUIDE PLATTER	1	92	FERRITE CORE	2
39	STICKER VOID	2	93	POWER CORD	1
41	LEVEL LENS	1	94	STICKER 'M'	1
42	CAP	4	95	LOADCELL ASSEMBLY	1
43	CASE MAIN UPPER	1	96	NAME PLATE SPEC	2
44	COVER PRINTER UPPER	1	97	NAME PLATE SERIAL	1
45	BLOCK B HINGE PLATTER	2	99	MAGENT	1
46	RUBBER PLATTER SUPPORT	5	100	STICKER LABEL SETTING	1
47	PLATTER SUPPORT	1	101	STICKER IMPORTANT	1

NO.	PART NAME	Q'TY	NO.	PART NAME	Q'TY
51	COVER HARNESS	1	102	BRACKET LEVEL	1
52	PWB PK-270C	1	103	PLATE A COVER	1
53	SHEET INSULATION	1	104	FRONT LCD ASSY	1

2.4 Elevated dual printer type

2.4.1 Exploded view

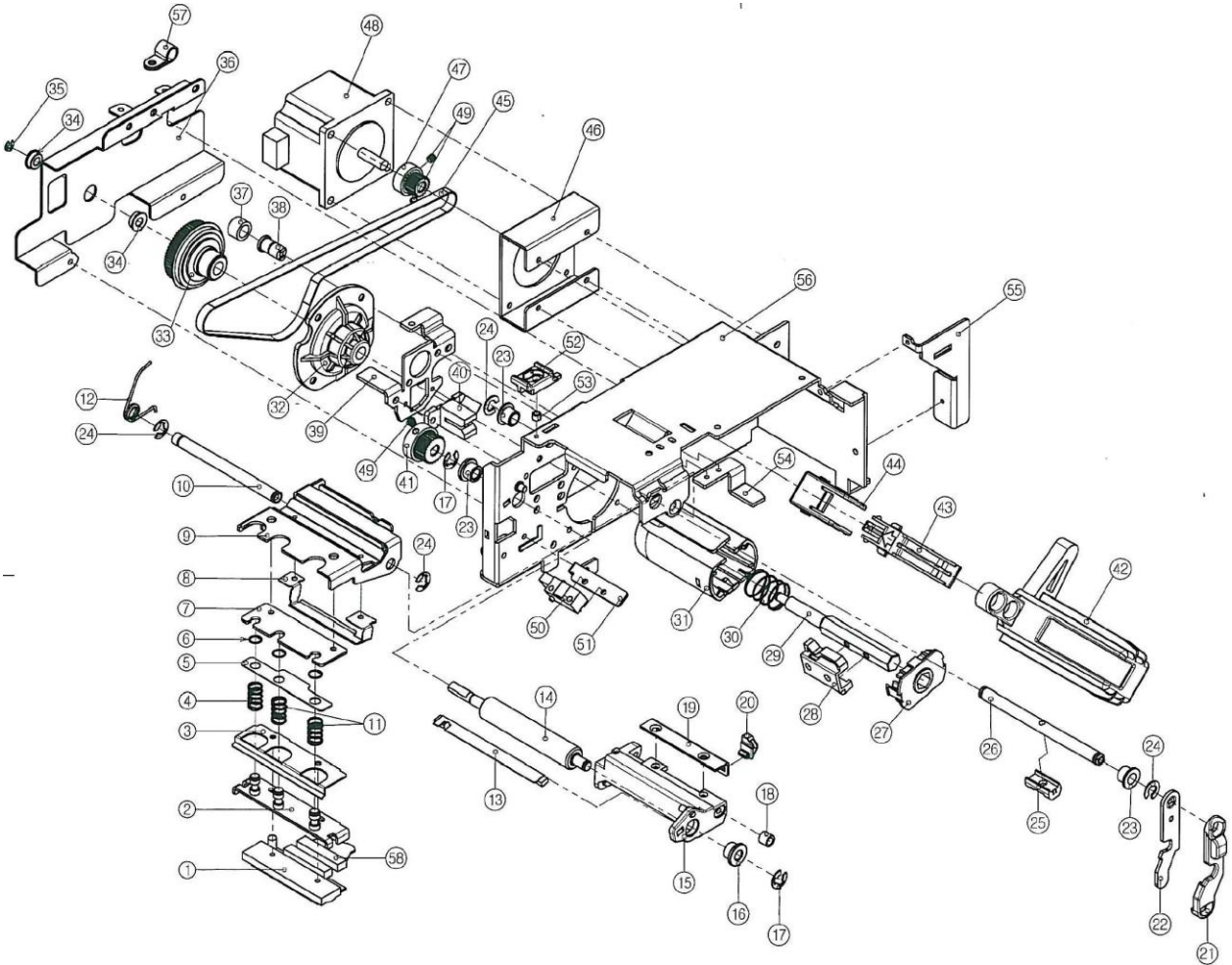

2.4.2 Parts list

NO.	PART NAME	Q'TY	NO.	PART NAME	Q'TY
1	THERMAL HEAD	1	30	SPRING COIL COMPRESSION	1
2	BRACKET HEAD	1	31	BOBBIN ROLL	1
3	COVER HEAD	1	32	HOUSING TORQUE LIMITER	1
4	SPRING COIL COMPRESSION	1	33	TORQUE LIMITER	1
5	PLATE A SPRING SUPPORT	1	34	BUSH	2
6	C-RING	3	36	COVER TIMING BELT	1
7	STAY HEAD	1	37	ROLLER SUPPORT CASSETTE	1
8	GUIDE LABEL	1	38	PIN SUPPORT BELT	1
9	BRACKET PRINTER	1	39	BRACKET LIMIT	1
10	SHAFT HEAD	1	40	HARNESS C3 SENSOR	1
11	SPRING COIL COMPRESSION	2	41	GEAR ROLLER	1
12	SPRING HEAD	1	42	HOLDER LABEL	1
13	PLATE AS PEEL SHAFT	1	43	LEVER GUIDE LABEL	1
14	ROLLER PRINTER	1	44	HOLDER GUIDE LABEL	1
15	TABLE LABEL	1	45	TIMING BELT	1
16	BUSH	2	46	BRACKET MOTOR	1
18	COLLAR	1	47	GEAR MOTOR	1
19	L PLATE B GUIDE LABEL	1	48	STEPPING MOTOR	1
20	GUIDE LABEL	1	50	PHOTO REFLECTOR	1
21	LEVER HANDLE	1	51	BRACKET SENSOR	1
22	PLATE B LEVER	1	52	BLOCK B LOCK	1
23	BUSH LEVER	2	53	COLLAR	1
25	BLOCK B LEVER	1	54	BRACKET MAGNET	1
26	SHAFT LEVER	1	55	COVER PRINTER FRAME	1
27	COVER ROLL	1	56	FRAME PRINTER	1
28	STOPPER HOLDER LABEL	1	57	CABLE CLAMPS	1
29	SHAFT STEP BOBBIN	1	58	HARNESS C2 HEAD	1

Chapter 3 Machine disassembly

3.1 Bench type

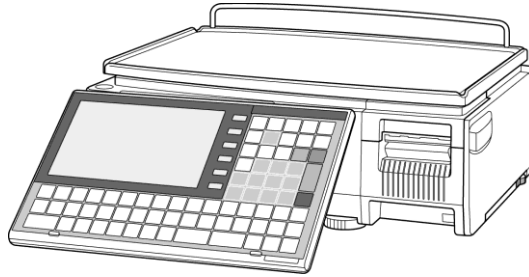

3.1.1 Upper case

1. Hold up the front side of the weigh platter and pull to remove the platter.

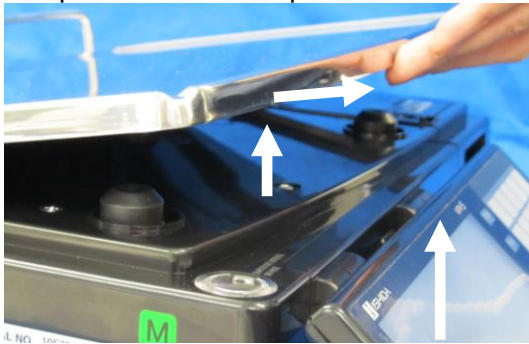

2. Remove the lock.



3. Raise the operation panel and remove the screw fixing the hinge cover.



4. Make the operation panel angle about 45° and pull out the hinge cover.



5. Remove the five screws (blue), two tapping screws (red), and one TP screw (green).

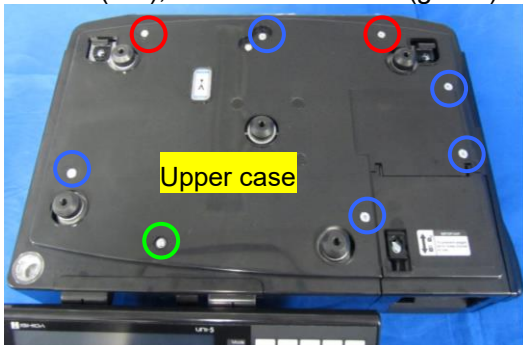

6. Remove the upper case.

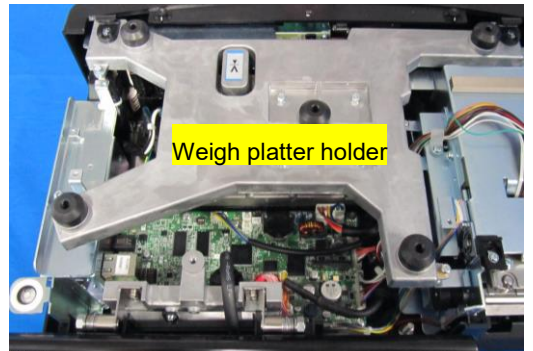

* Reverse this procedure for assembly.

3.1.2 Weigh platter holder

1 Make sure that the upper case is removed.
(Refer to section 3.1.1)

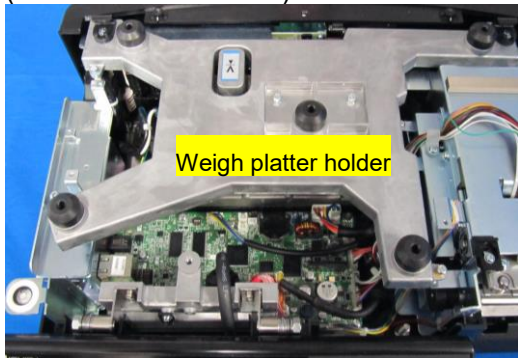

2 Remove the four screws fixing the weigh platter holder.

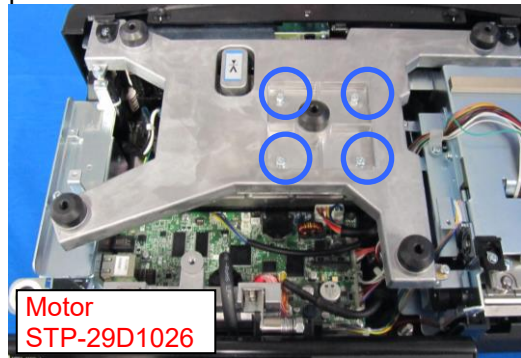

3 Remove the weigh platter holder.

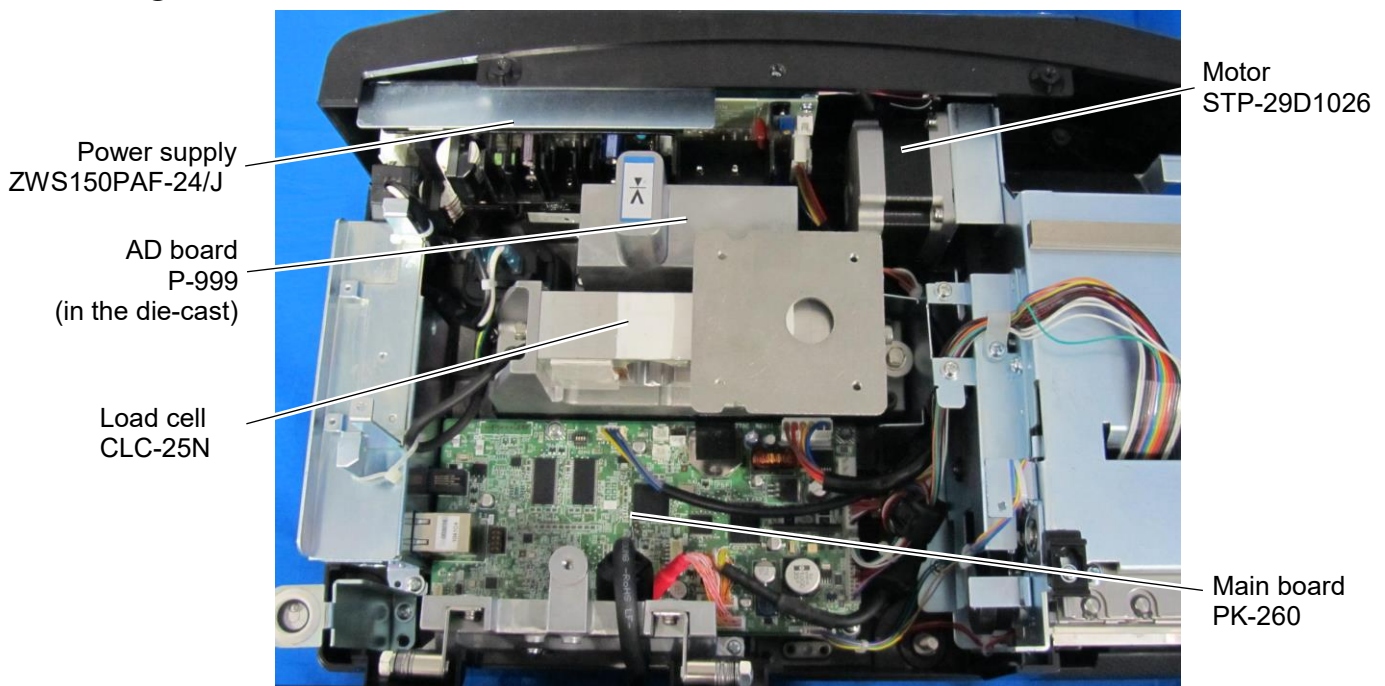

* Reverse this procedure for assembly.

3.1.3 Main board

1. Unplug all harnesses connected to the main board.

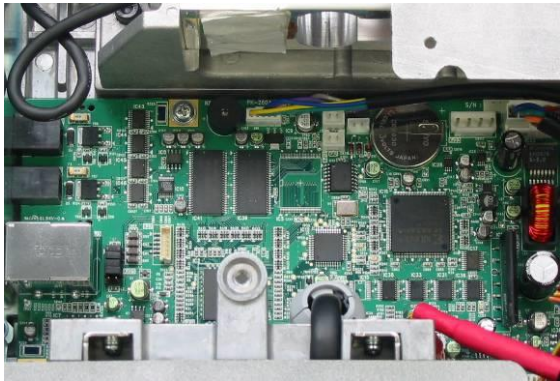

2. Remove the three screws fixing the main board.

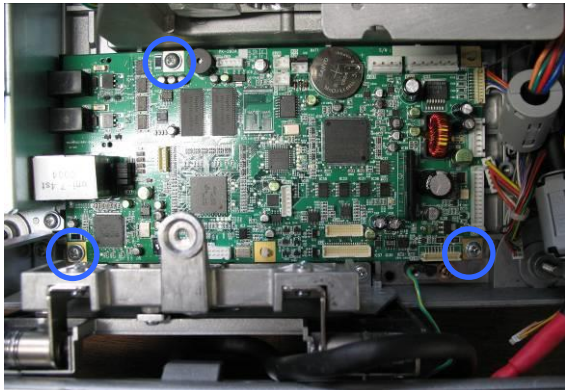

3. Squeeze the two spacers to remove the main board.

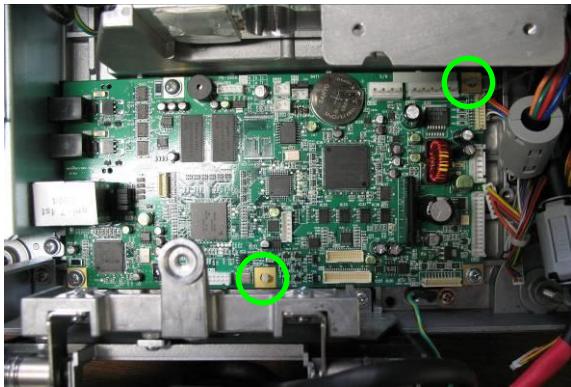

* Reverse this procedure for assembly.

3.1.4 Operation panel



REFERENCE

Refer to Technical Reports SC236115 and SC236116 at the beginning.

1. Remove the seven fixing screws located on the bottom of the operation panel.
2. Remove the bottom case of the operation panel.



3. Unplug all harnesses and remove the fixing screws to detach the touch panel LCD with the bracket.
4. Unplug the harnesses.

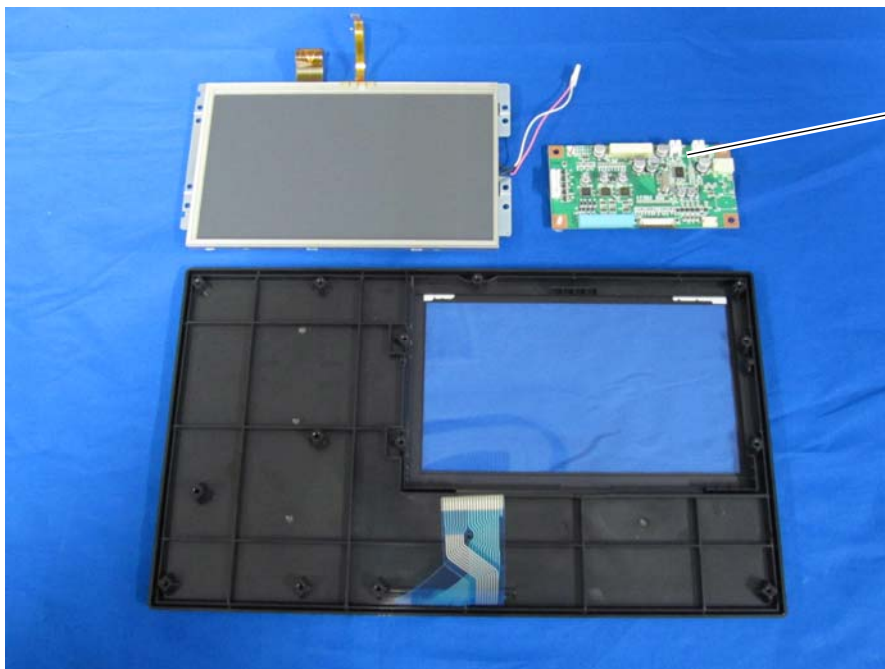
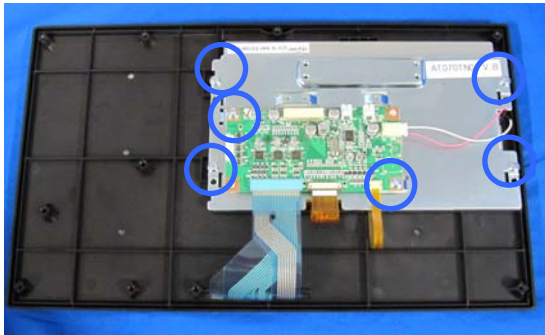

Display/
Key control board
PK-261

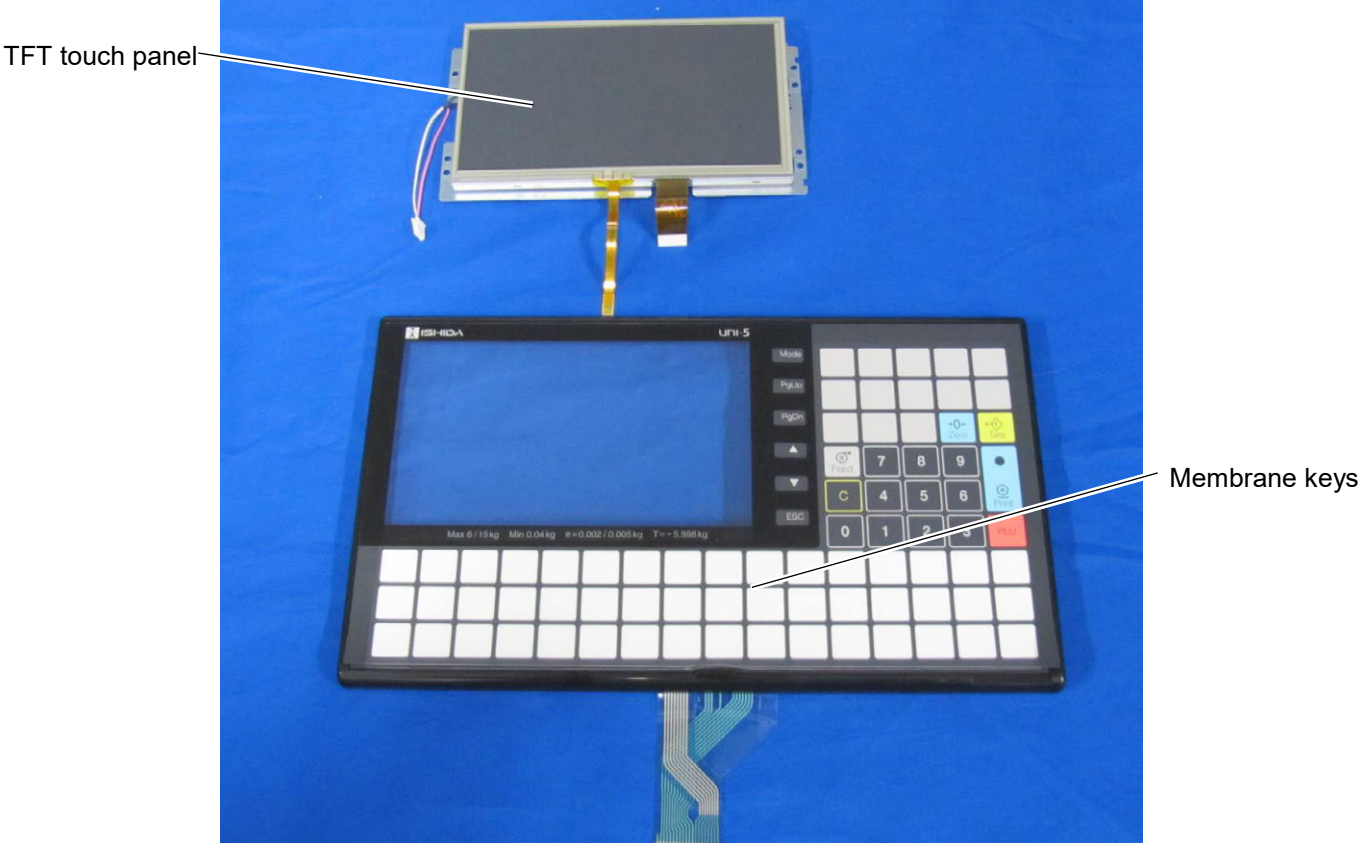

* Reverse this procedure for assembly.

3.1.5 Customer display

1. Disengage the five hooks located on the bottom of the machine using a slotted screwdriver.



2. Remove the four screws fixing the weigh platter holder.

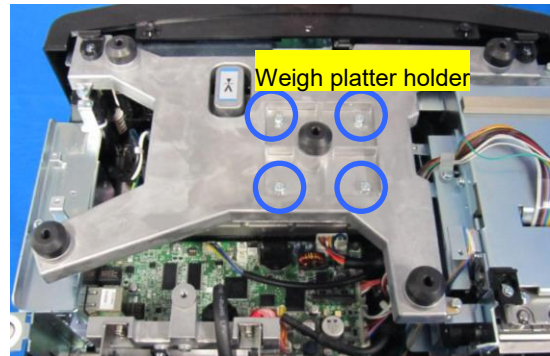

3. Remove the weigh platter holder and unplug the harness connected with the main board.

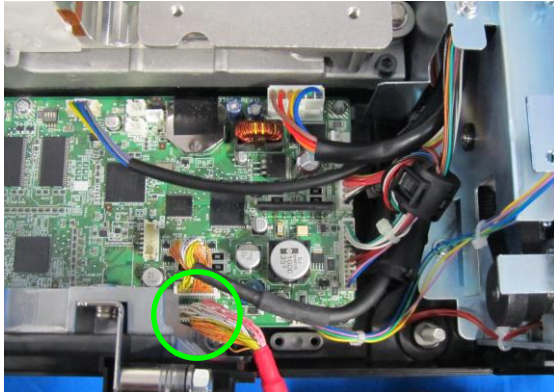

4. Detach the customer display unit.

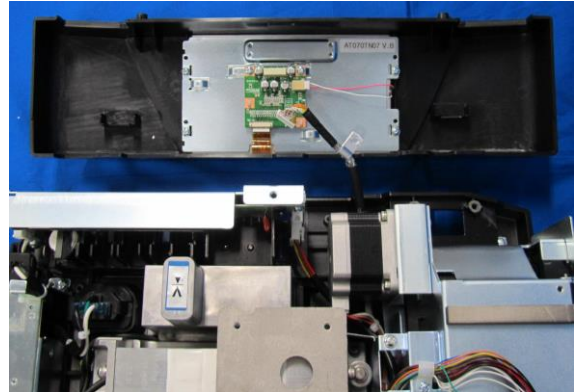

5. Remove the fixing screws to detach the display LCD with the bracket.

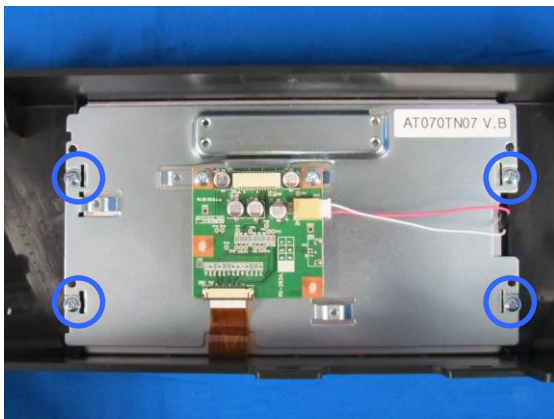

6. Unplug the harnesses.

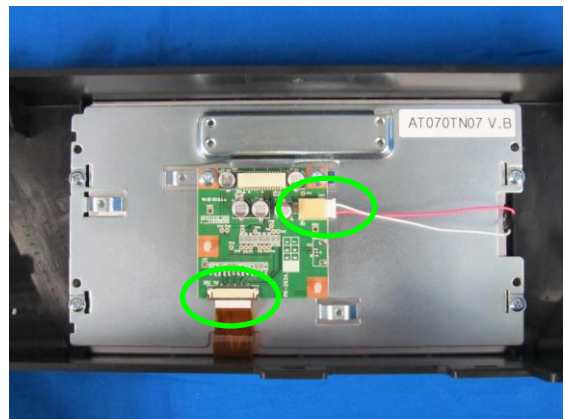

Detach the display control board and TFT LCD.

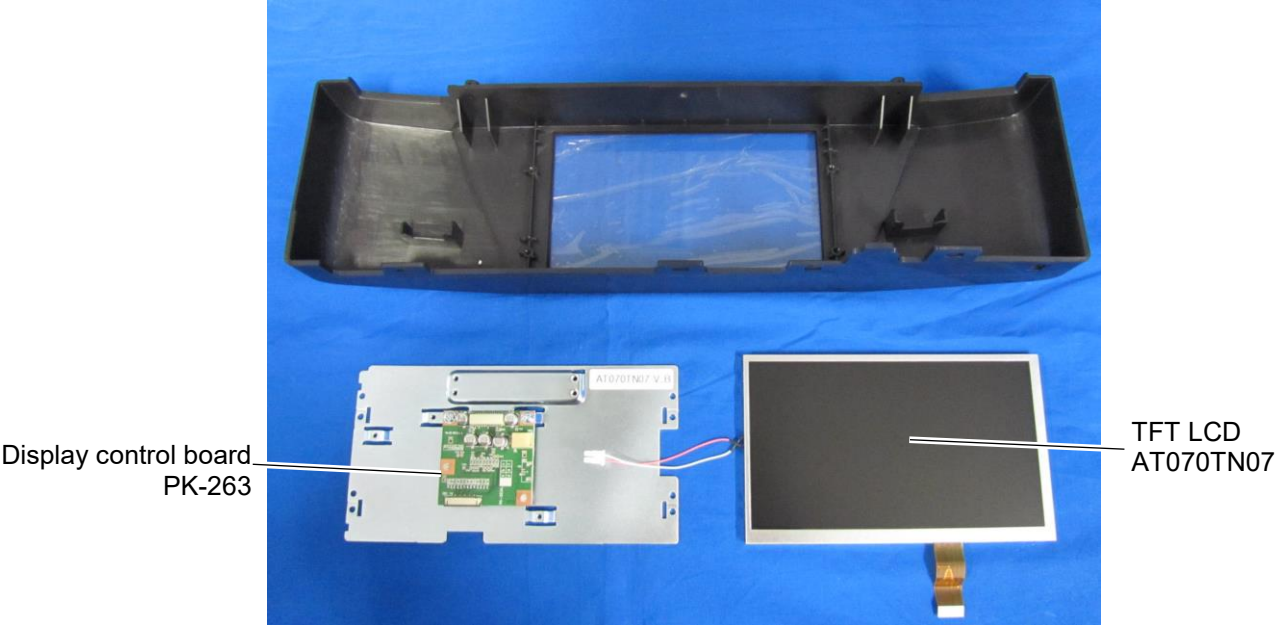

* Reverse this procedure for assembly.

3.1.6 Label sensor

1. This photo shows the label sensor.

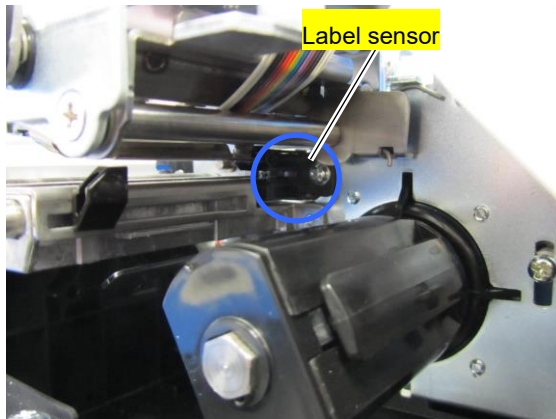

3.1.7 Peel Sensor

1. This photo shows the peel sensor.

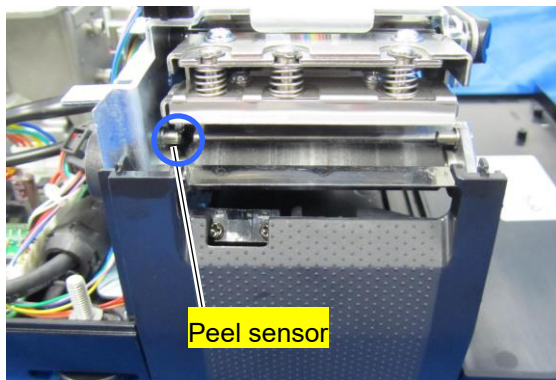

2. Remove the two screws securing the front printer cover.



3. Remove two screws securing the sensor and unplug the harness.

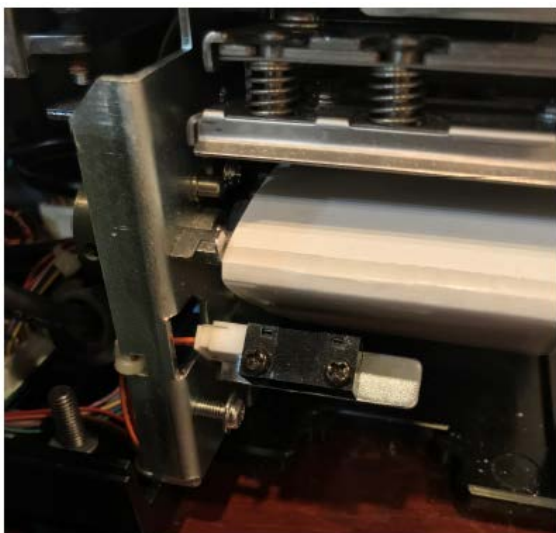

4. Adjust the bracket to position the sensor to avoid false readings from the cover or peel bar.

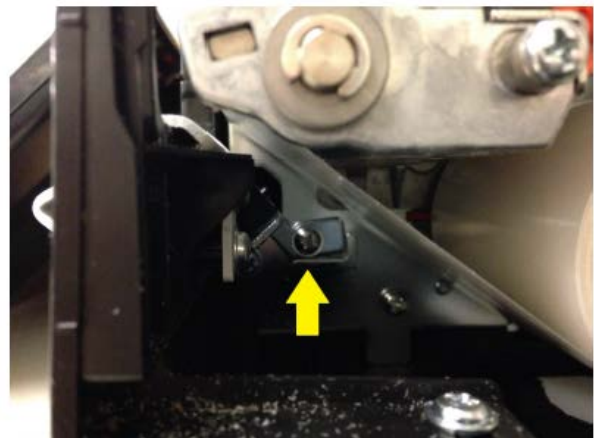

3.1.8 Thermal head unit

1. Open the side cover.

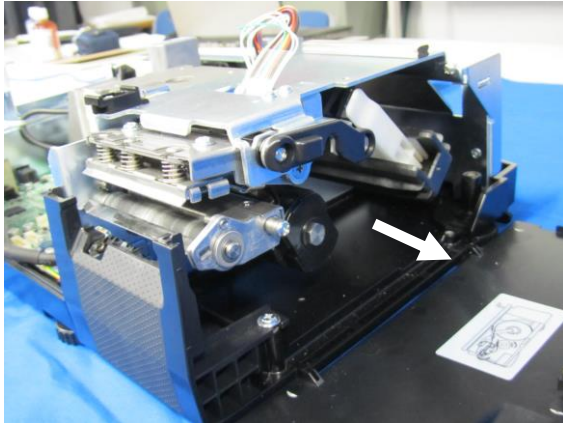

2. Raise the lock bar.



3. Squeeze the springs by holding up the head unit and pull out the thermal head unit.

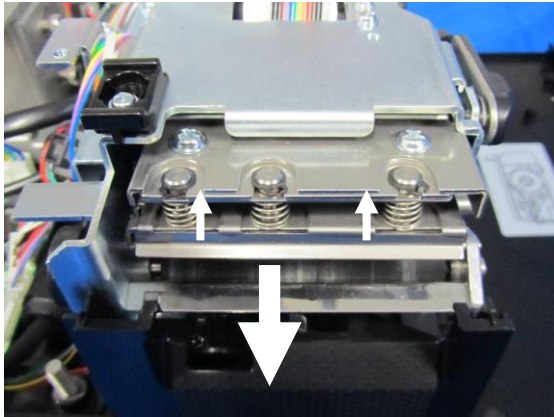

4. Unplug the connector and remove the two screws.

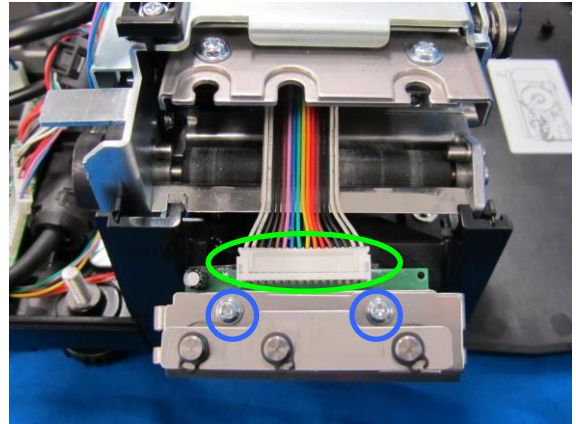

5. This photo shows the breakdown of the thermal head unit.

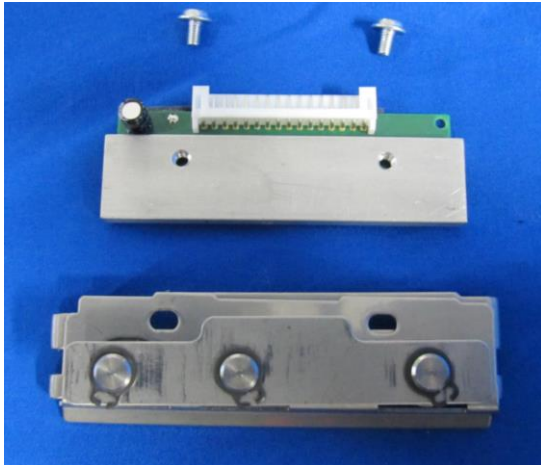

* Reverse this procedure for assembly.

3.1.9 Load cell & A/D board

1. This photo shows the inside of the machine.
2. Remove the hexagon socket head bolt fixing the load cell unit.

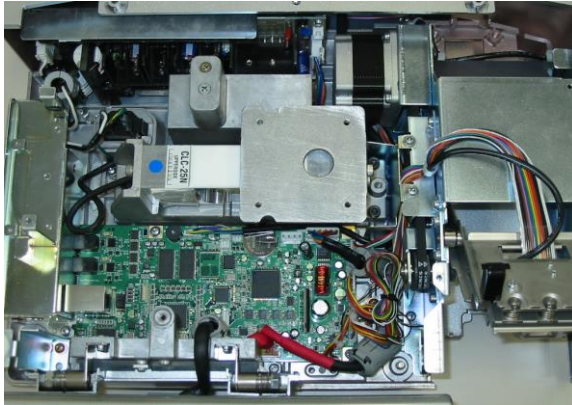

3. Remove the two hexagon socket head bolts at the other end and detach the load cell unit.
4. Remove the two screws to remove the die-cast bracket.

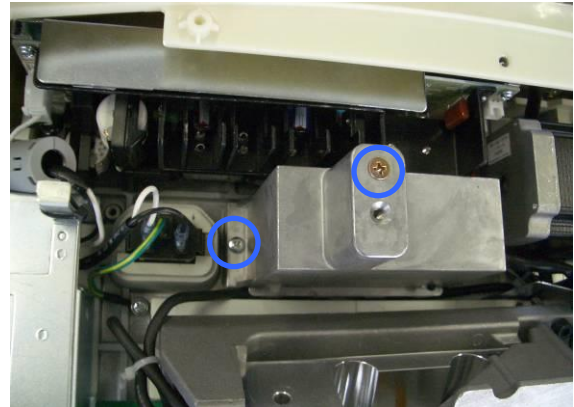
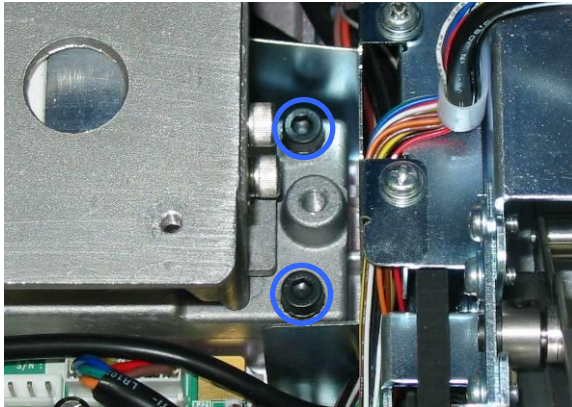

5. Unplug the harnesses and squeeze the two spacers (green) to detach the AD board.

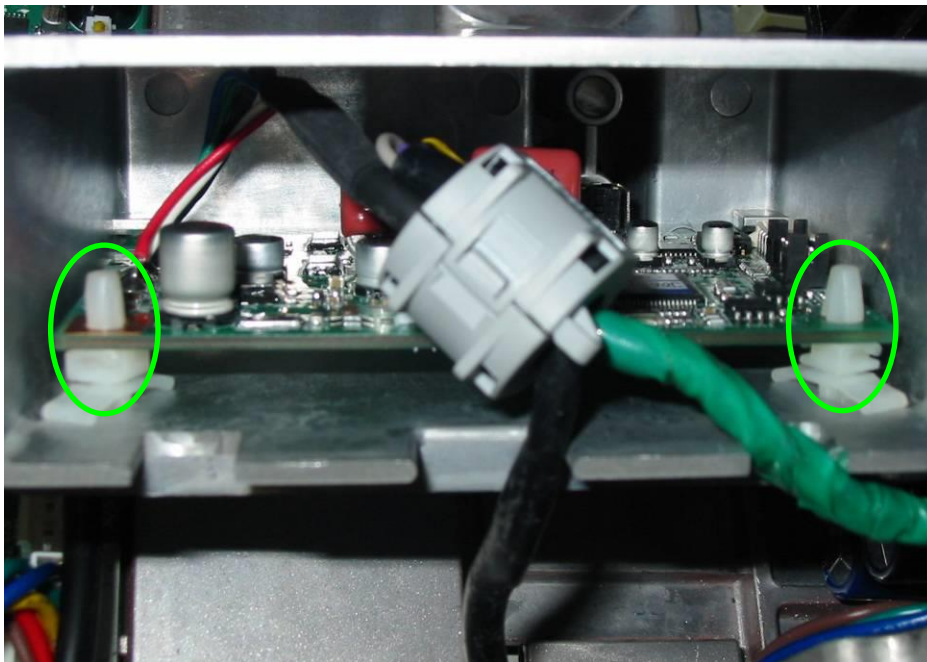

Note:

When inserting the A/D board, be sure to hold it with two hooks inside.



* Reverse this procedure for assembly.

3.1.10 Power supply unit

1. Disengage the five hooks at the bottom of the machine using a slotted screwdriver.



2. Detach the customer display unit and remove the two screws fixing the power supply unit.

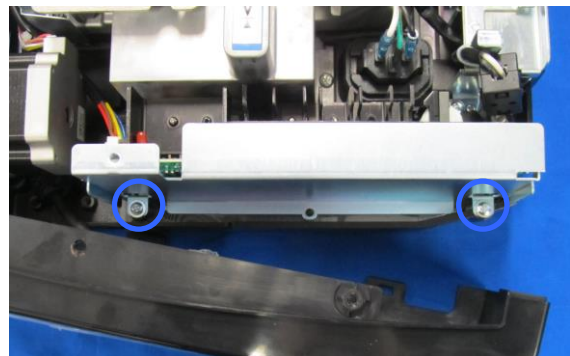

3. Remove the power supply unit.



* Reverse this procedure for assembly.

3.1.11 Motor unit

1. This photo shows the motor unit.

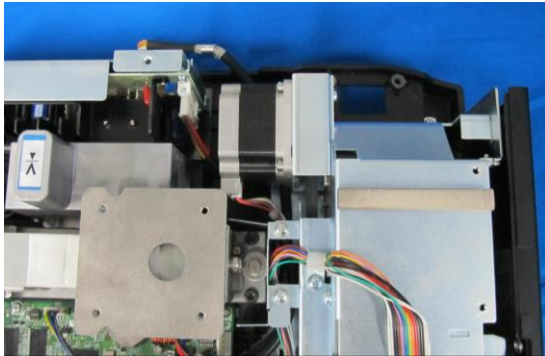

3.1.12 Wireless LAN unit

- 1 Make sure that the upper case of the main unit is removed.



- 2 This photo shows the wireless LAN unit installed in the main unit.



- 3 Unplug the LAN connector.

- 4 Unplug the connector from the main board.

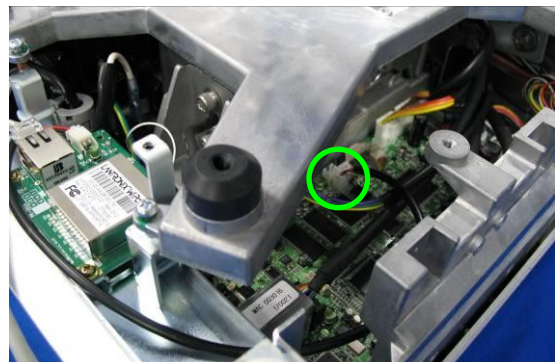

- 5 The cable connected with the main board and the LAN cable are unplugged.

- 6 Turn to remove the antenna.

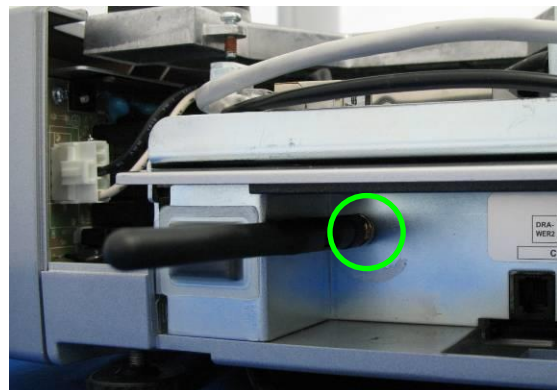
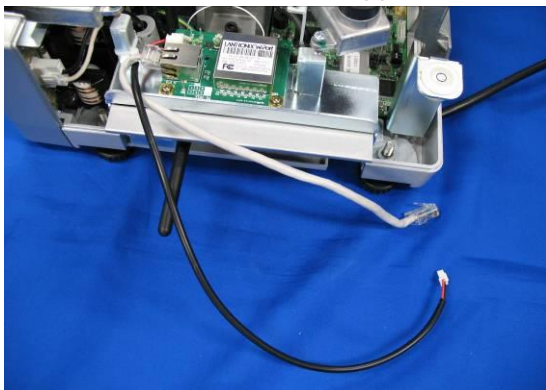

- 7 When removing the LAN board, remove the two screws.

- 8 This photo shows the constituent parts for the wireless LAN unit.



* Reverse this procedure for assembly.

3.2 Pole type

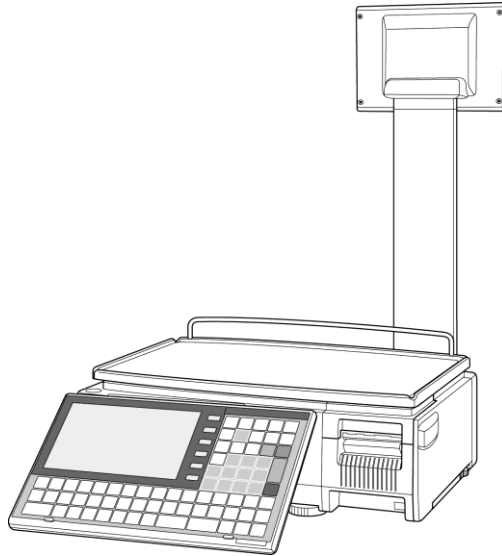

3.2.1 Pole unit

1 Remove the screw fixing the blind plate located on the bottom of the pole unit.

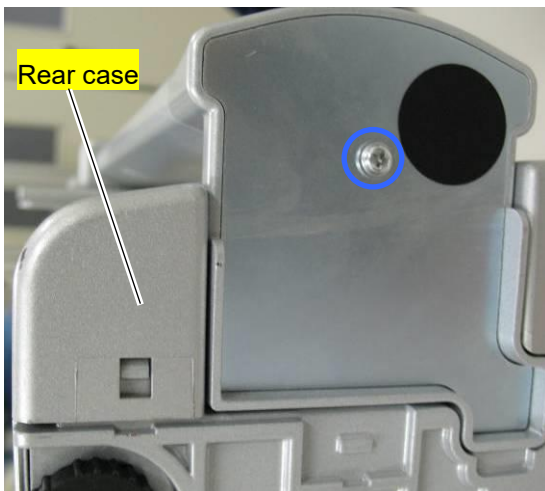

2 Remove the three hexagon socket head bolts and separate the pole unit from the machine.

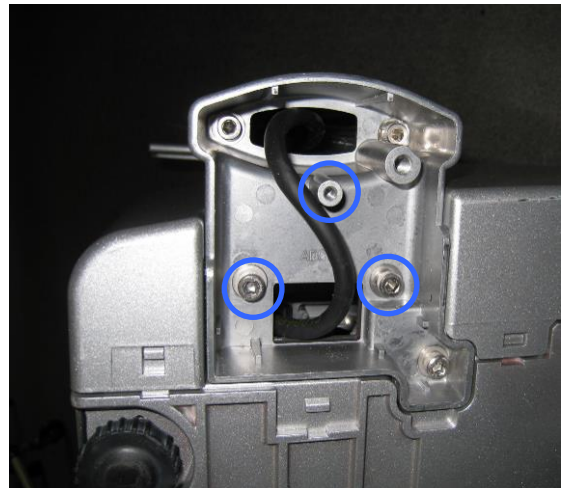

3. Unplug the display harness connector on the main board to remove the pole unit.



* Reverse this procedure for assembly.

3.2.2 Customer display unit

1. Remove the four screws fixing the rear case of the customer display unit.

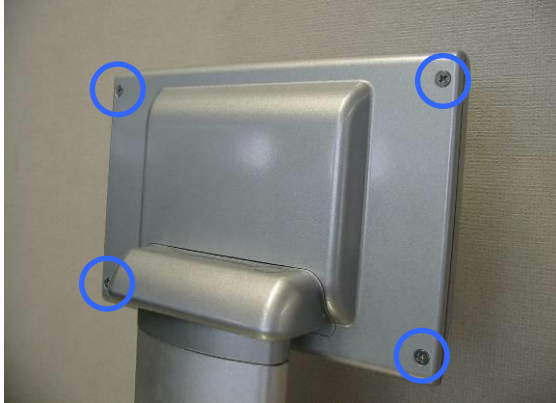

2. Detach the front panel of the customer display unit.



3. Unplug the connector.



4. Remove the two screws and unplug the two harnesses.

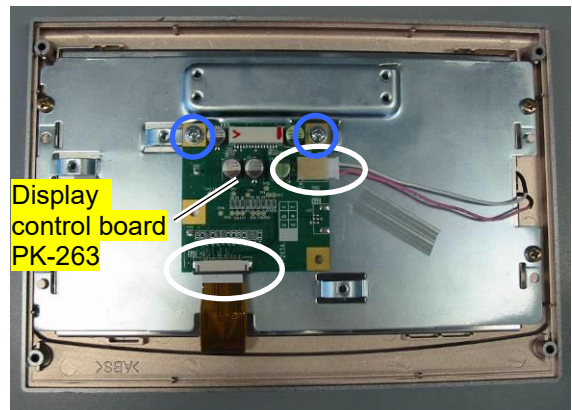

5. Remove the display control board.

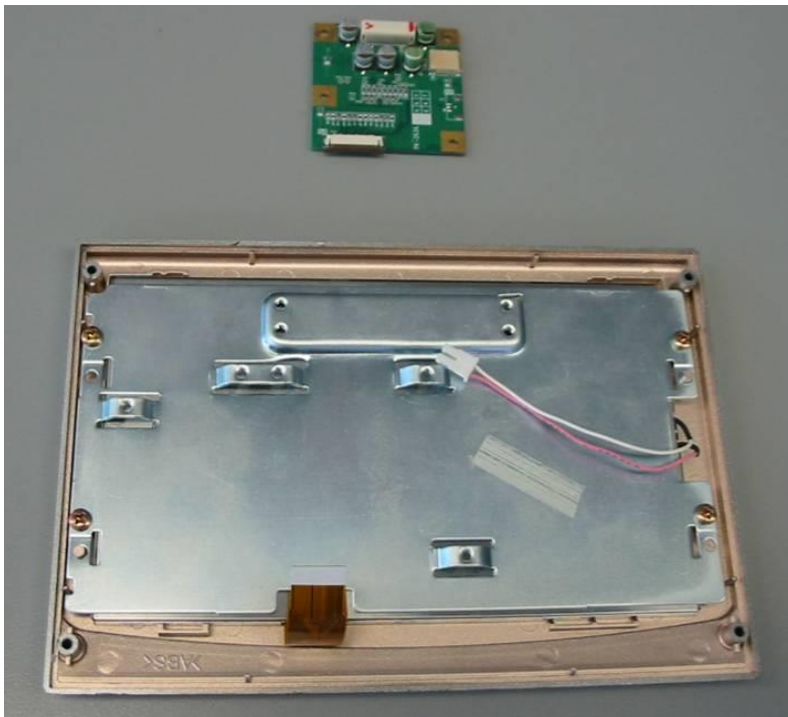

* Reverse this procedure for assembly.

3.3 Self-service type

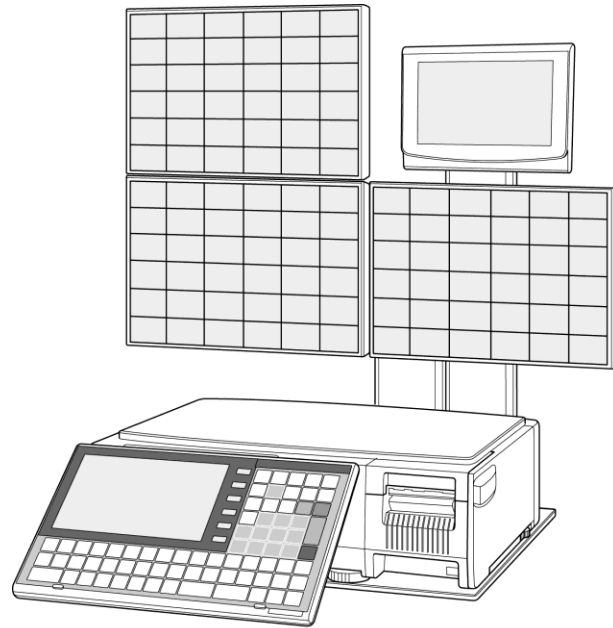

3.3.1 Self-service panel unit

1. Gently lay down the machine and self-service panel unit so that you can work from the bottom.

2. Remove the screw fixing the cable clamp and the grounding terminal.

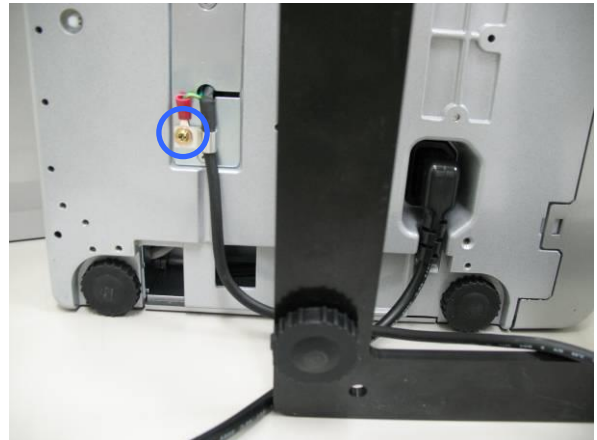
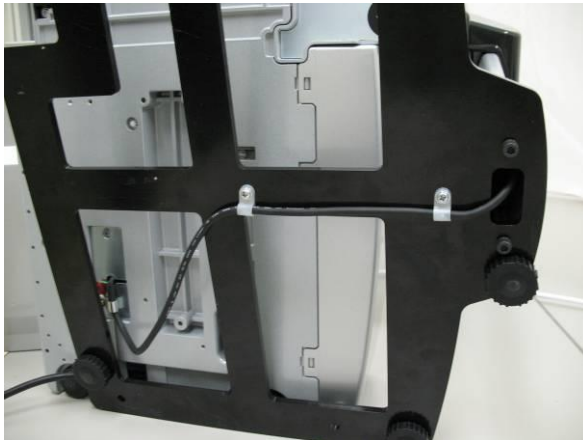

3. Remove the two screws fixing the blind plate.

4. Detach the blind plate and unplug the connector.

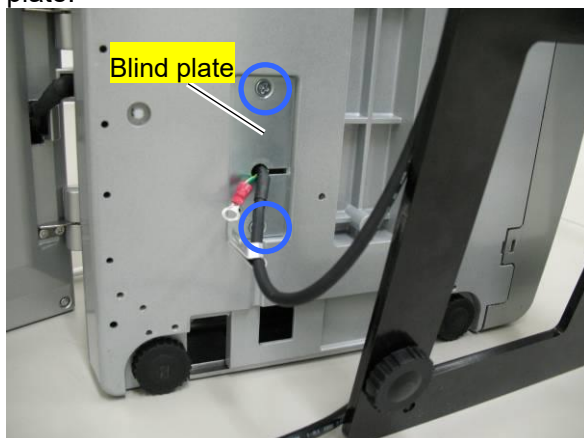

5. Remove the two screws fixing the cable clamps.

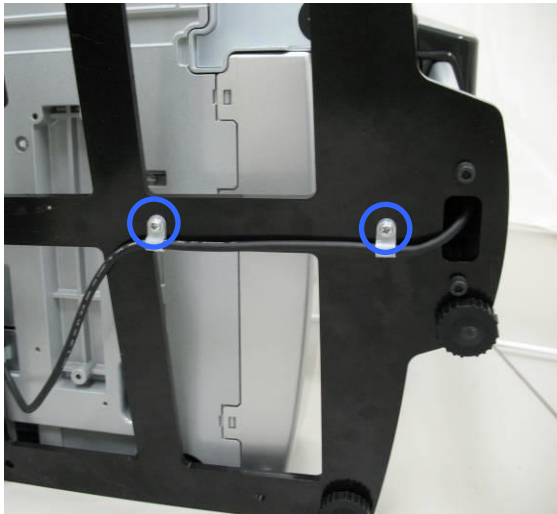

6. Separate the self-service panel unit from the machine.

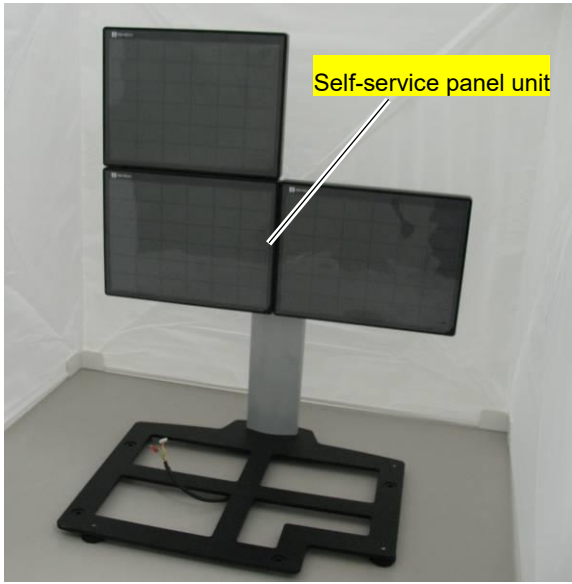

* Reverse this procedure for assembly.

3.3.2 Panel control board

1. Lift to disengage the two hooked places and detach the blind cover of the self-service panel unit.

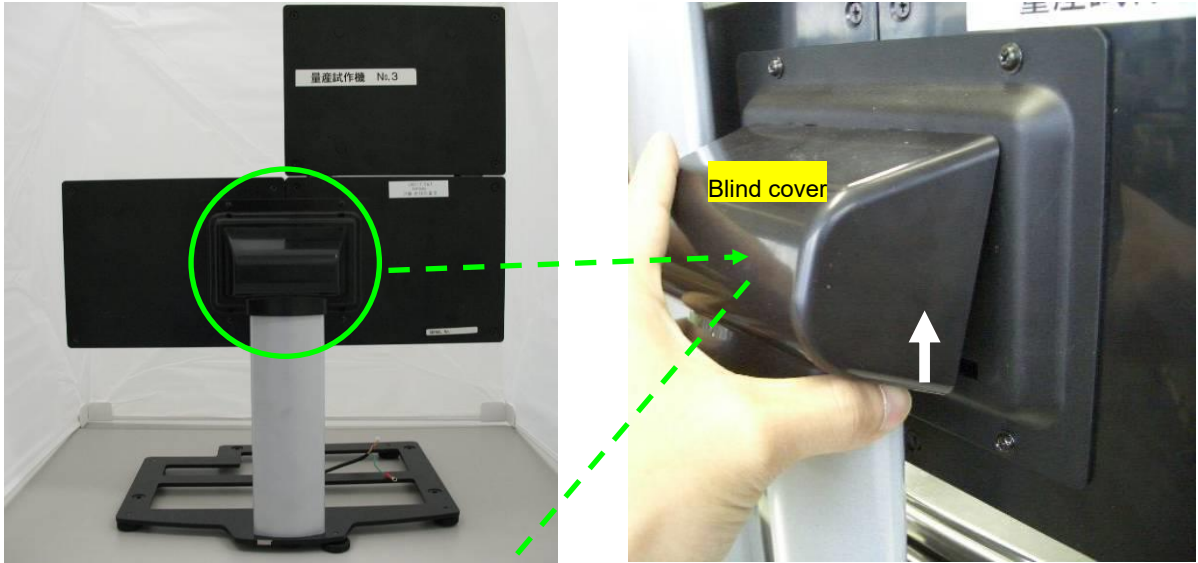

2. Remove the four screws to detach the rear cover.

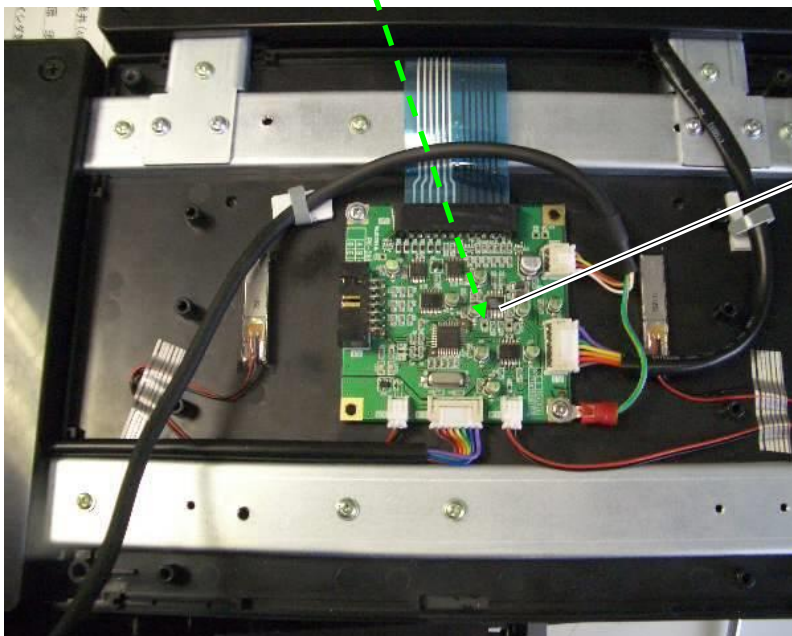

* Reverse this procedure for assembly.

3.4 Elevated type

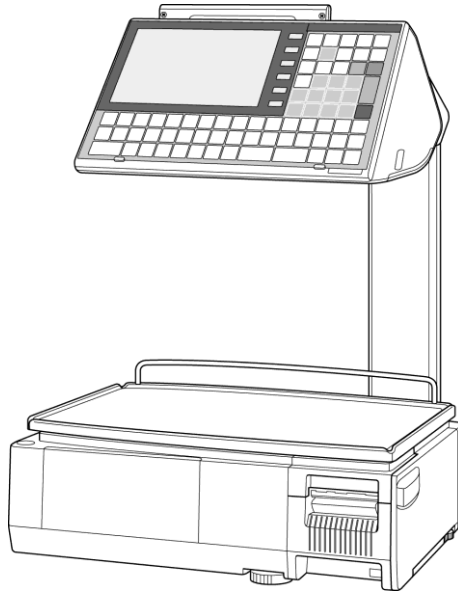

3.4.1 Operation panel unit

1 Remove the two screws located on the bottom of the operation panel unit.



2 Remove the two screws located at the customer display side.



3 Remove the screw located on the bottom of the operation panel unit.

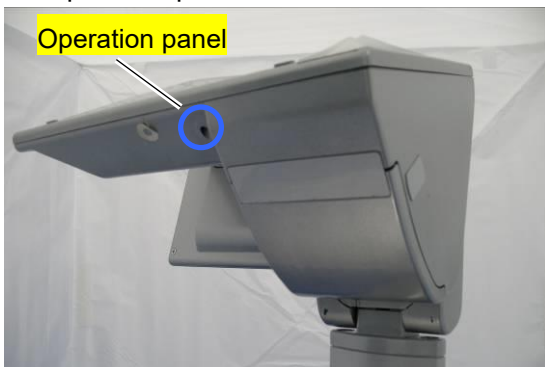

4. Peel off the blind plate.



5. Remove the two screws fixing the roll holder.



6. Pull out the holder.



7. Remove the screw fixing the operation panel.

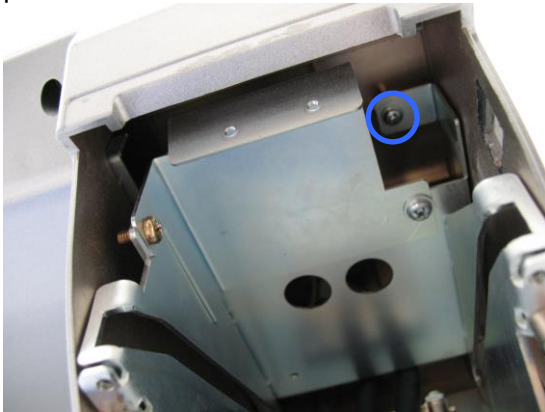

8. Detach the operation panel.

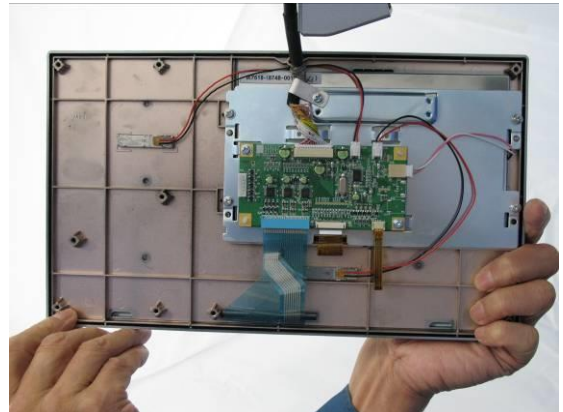

* Reverse this procedure for assembly.

3.4.2 Customer display unit

1. Remove the two screws fixing the customer display unit.



2. Remove the two screws (blue) and loosen the other two screws (green).

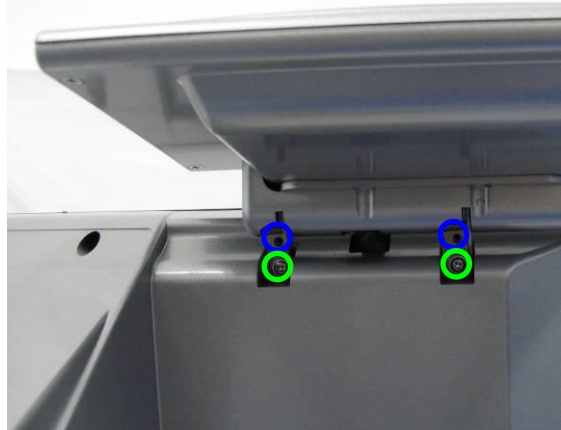

3. Detach the customer display unit and remove the four fixing screws.



4. Open the customer display unit.

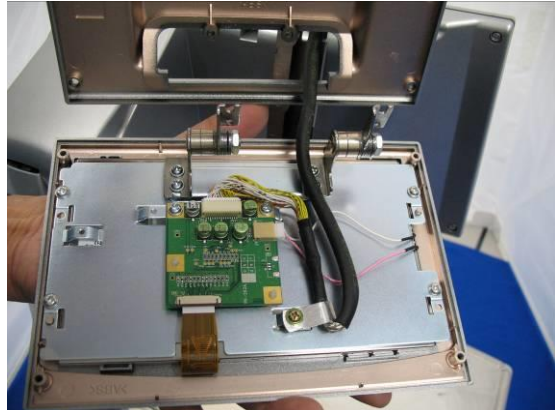

* Reverse this procedure for assembly.

3.4.3 Elevated unit

1. Turn to remove the level adjusting foot.



2. Remove the three screws fixing the pole bottom cover.



3. Remove the three hexagon socket head bolts fixing the elevated unit.

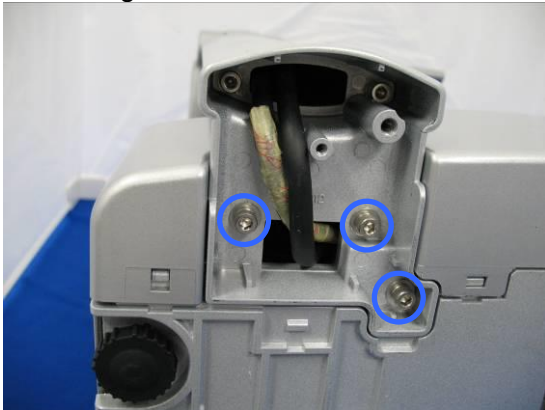

* Reverse this procedure for assembly.

Chapter 4 Mechanical adjustment

4.1 Four corner limit space

Adjust the limit spaces at four corners of the weigh platter holder to become the following values.

(1) 2mm, (2) 2mm, (3) 2.5mm, (4) 3.2mm

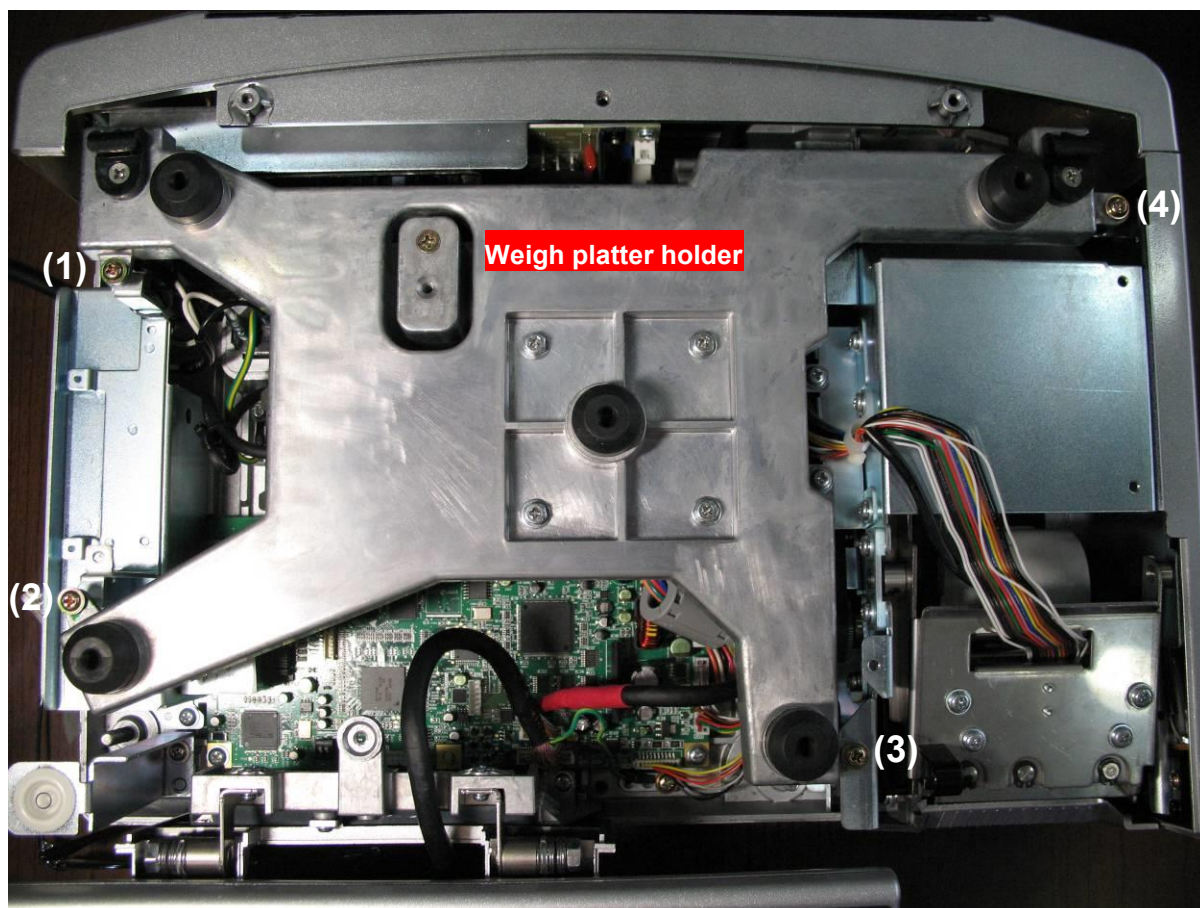

4.2 Print position

1. Open the side cover.

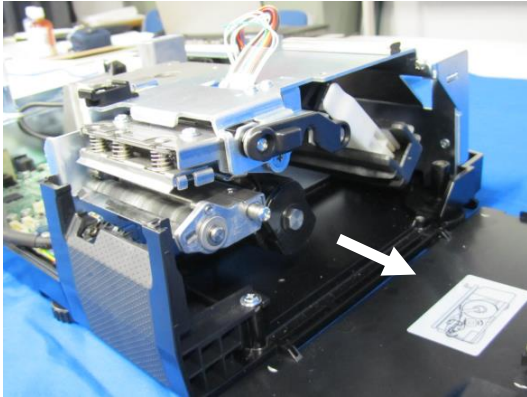

2. This photo shows the position of the thermal head unit.

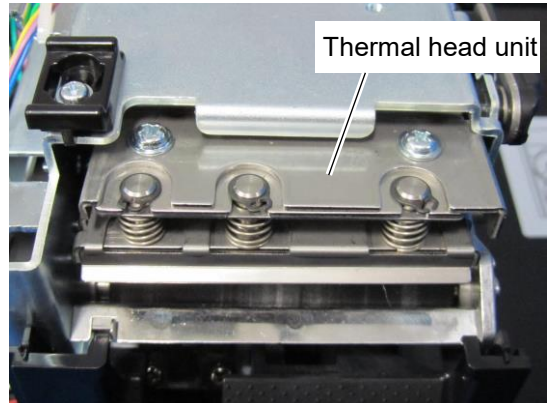

3. Loosen the two screws and move the thermal head unit back and forth and around for position adjustment. Be sure to tighten the screws after adjustment.

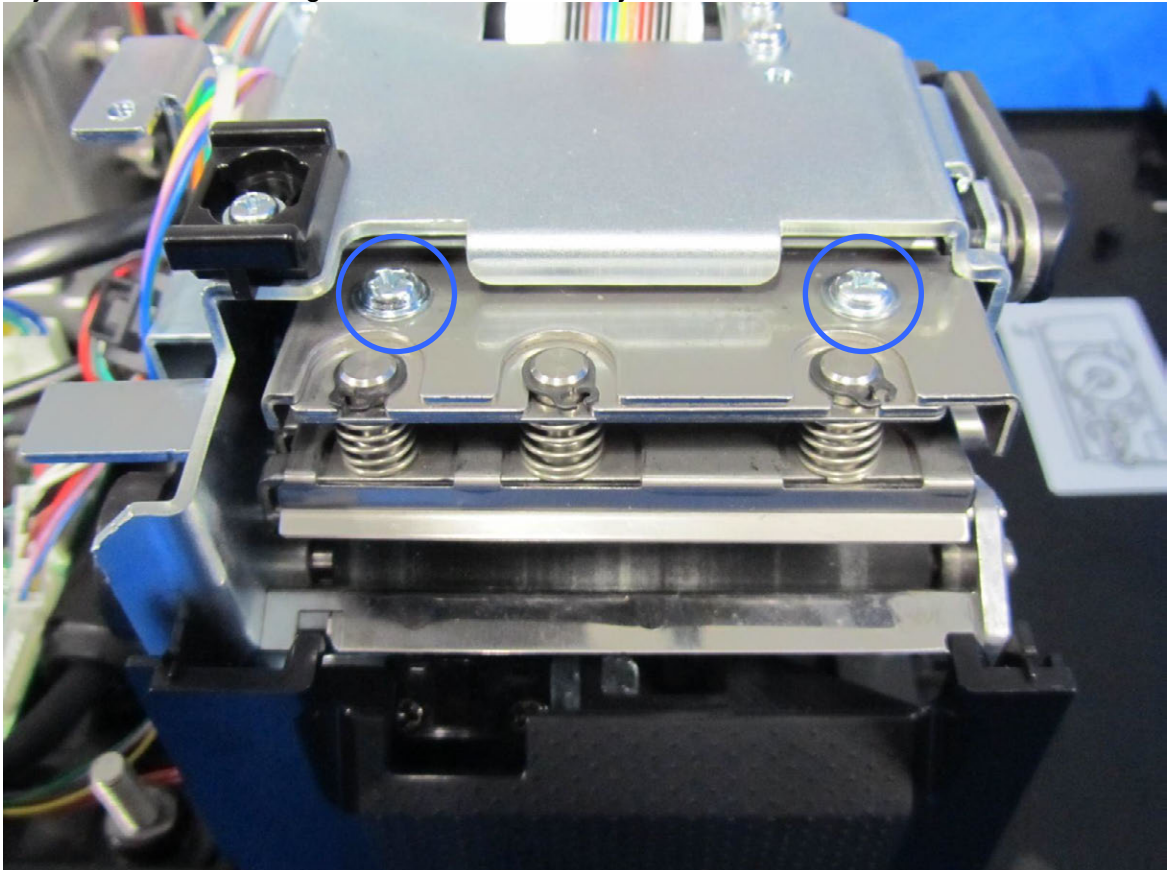

4.3 Thermal head position

1. Open the side cover.

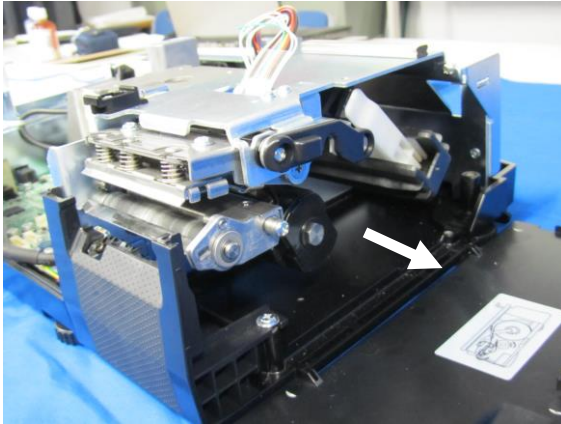

2. Raised the lock bar.

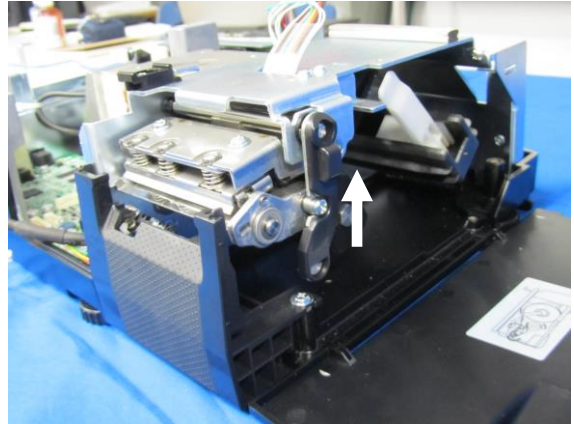

3. Squeeze the springs by holding up the head bracket and pull out the thermal head unit.

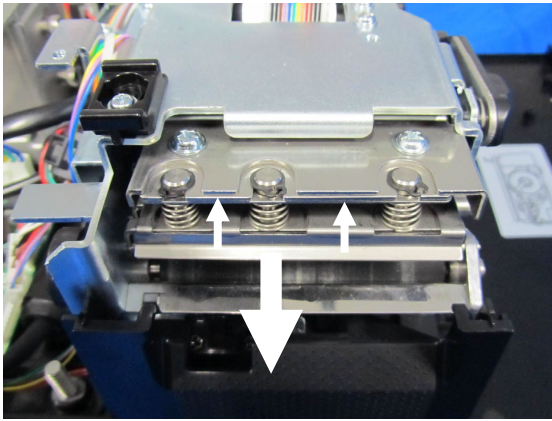

4. Loosen the two screws to adjust the gap between the bracket and the left end of the thermal head.

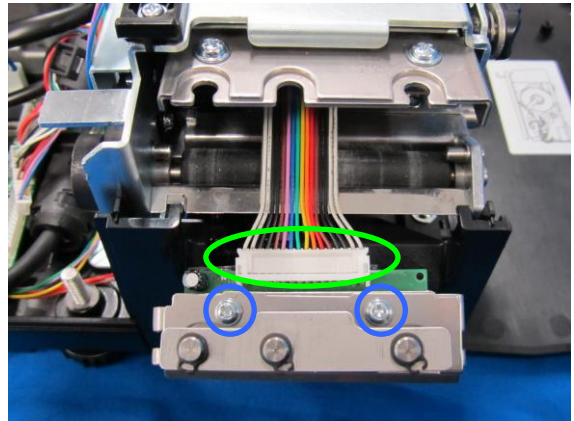

Chapter 5 Electrical signals

5.1 Main board (PK-260)

Before replacing the main board PK-260, make sure to turn ON the battery switch and every switch 1 is turned OFF.

5.1.1 XJ16

No.	Signal Name	Direction	Opposite Side
1,2,5,7,9,11,14, 16,18,25,26,40	GND	-	PK-261(XJ3)
3,4	DC+5V power supply for LCD	→	
6,8,10,12,13, 15,17,19,20	LCD control signal	→	
21,22	AC power supply for LCD	-	
23	DC-10V power supply for LCD	-	
24	DC+15V power supply for LCD	-	
27	DC+15V power supply for LCD backlight	-	
28,29	Light control signal for LCD backlight	←	
30	External buzzer signal	→	
31	Vibration signal	→	
32,33	DC+5V	-	
34 - 39	Membrane key control signal	↔	

5.1.2 XJ20

No.	Signal Name	Direction	Opposite Side
1 - 14	Debug signal	↔	Unused

5.1.3 XJ2

No.	Signal Name	Direction	Opposite Side
USB-1	Vbus	-	LAN, USB memory
USB-2	D-	↔	
USB-3	D+	↔	
USB-4	GND	-	
LAN-1	TX+	→	
LAN-2	TX-	→	
LAN-3	RX+	←	
LAN-4	Not connected		
LAN-5	Not connected		
LAN-6	RX-	←	
LAN-7	Not connected	-	
LAN-8	Not connected	-	

5.1.4 XJ17

No.	Signal Name	Direction	Opposite Side
1,2,5,7,9,11, 14,16,29,30	GND	-	PK-263(XJ1)
3,4	DC+5V power supply for LCD	-	
6,8,10,12,13, 15,17,18,19	LCD control signal	→	
20,21	AC power supply for LCD	-	
22	DC-10V power supply for LCD	-	
23	DC+15V power supply for LCD	-	
26	DC+15V power supply for LCD backlight	-	
27,28	Light control signal for LCD backlight	→	
24,25	DC+5V	-	

5.1.5 XJ6

No.	Signal Name	Direction	Opposite Side
1	D#		P-999
2	D		
3	DC+12V		
4	GND		
5	FG		

5.1.6 XJ1

No.	Signal Name	Direction	Opposite Side
1	DC3.3V	-	Unused
2	GND	-	
3	RXD	→	
4	TXD	→	

5.1.7 XJ10

No.	Signal Name	Direction	Opposite Side
1	BAT+	-	Unused
2	GND	-	

5.1.8 XJ7

No.	Signal Name	Direction	Opposite Side
1	DC+5V	-	Unused
2	GND	-	

5.1.9 XJ22

No.	Signal Name	Direction	Opposite Side
1	DC+5V	-	Unused
2	GND	-	
3	TxD	→	
4	RTS	→	
5	RxD	←	
6	CTS	←	

5.1.10 XJ8

No.	Signal Name	Direction	Opposite Side
1	DC+5V	-	Unused
2	GND	-	

5.1.11 XJ14

No.	Signal Name	Direction	Opposite Side
1	DC+5V	-	Thermal head
2	GND	-	
3,4,6,7,8, 9,10,27	Thermal head control signal	↔	
11,12	Thermistor input signal	←	
20,21,22,23, 24,25,26	DC+24V	-	
13,14,15,16, 17,18,19	GND	-	

5.1.12 XJ13

No.	Signal Name	Direction	Opposite Side
1	B#	→	Stepping motor for label feeding
2	B	→	
3	A#	→	
4	A	→	
5,6	DC+24V	-	

5.1.13 XJ15

No.	Signal Name	Direction	Opposite Side
1	Peel sensor DC+5V	-	Peel sensor Label sensor
2	Peel sensor SENS_IN	←	
3	Peel sensor GND	-	
4	Label sensor DC+5V	-	
5	Label sensor LED_GND	-	
6	Label sensor LED_VCC	-	
7	Label sensor SENS_IN	←	
8,9,10	Label sensor GND	-	

5.1.14 XJ4

No.	Signal Name	Direction	Opposite Side
1	Unused	-	Cash drawer 1
2	DC+24V for drawer	-	
3	GND	-	
4	Unused	-	

5.1.15 XJ11

No.	Signal Name	Direction	Opposite Side
1,2,3	DC+24V main power supply	-	Switching power supply
4,5,6	GND	-	

5.1.16 XJ12

No.	Signal Name	Direction	Opposite Side
1,2	DC+24V	-	Unused
3,4	GND	-	

5.1.17 XJ3

No.	Signal Name	Direction	Opposite Side
2	USB_VBUS	-	
4	USB_D+	↔	
6	USB_D-	↔	
8	USB_GND	-	
10	NONE	-	
1	VBUS	-	
3	D+	↔	
5	D-	↔	
7	GND	-	

5.2 Key/ LCD board (PK-261)

5.2.1 XJ1

No.	Signal Name	Direction	Opposite Side
1	DC+5V	-	Unused
2	MODE	→	
3	RESET	←	
4	Unused	-	
5,6	GND	-	

5.2.2 XJ2

No.	Signal Name	Direction	Opposite Side
1	X1	→←	Touch panel
2	X2	→←	
3	Y1	→←	
4	Y2	→←	

5.2.3 XJ3

No.	Signal Name	Direction	Opposite Side
1,2,5,7,9,11,14, 16,18,25,26,40	GND	-	PK-260(XJ1)
3,4	DC+5V power supply for LCD	→	
6,8,10,12,13, 15,17,19,20	LCD control signal	→	
21,22	AC power supply for LCD	-	
23	DC-10V power supply for LCD	-	
24	DC+15V power supply for LCD	-	
27	DC+15V power supply LCD backlight	-	
28,29	Light control signal for LCD backlight	←	
30	External buzzer signal	→	
31	Vibration signal	→	
32,33	DC+5V	-	
34 - 39	Membrane key control signal	↔	

5.2.4 XJ4

No.	Signal Name	Direction	Opposite Side
1	GND	-	Unused
2	DIM	→	
3	DC+5V	-	

5.2.5 XJ5

No.	Signal Name	Direction	Opposite Side
2,20	DC+5V	-	LCD
1,21	GND	-	
25	DC+5V power supply for LCD	-	
26	LCD GND	-	
10,11	AC power supply for LCD	-	
3	DC-10V power supply for LCD	-	
4	DC+15V power supply for LCD	-	
Others	LCD control signal	↔	

5.2.6 XJ6

No.	Signal Name	Direction	Opposite Side
1	DC+5V	-	LCD backlight
2	GND	-	

5.2.7 XJ8

No.	Signal Name	Direction	Opposite Side
1,2,3,4, 5,6,7,8	Key scanning KS0 - KS7	→	Membrane key
9,10,11,12, 13,14,15,16, 17,18,19	Key data KD0 - KD10	←	
20	Unused	-	

5.2.8 XJ9

No.	Signal Name	Direction	Opposite Side
1	DC+5V	-	Unused
2	GND	-	

5.2.9 XJ10, 11

No.	Signal Name	Direction	Opposite Side
1	DC+5V for vibration	-	Vibration unit
2	GND	-	

5.3 LCD board (PK-263)

5.3.1 XJ1

No.	Signal Name	Direction	Opposite Side
1,2,5,7,9,11, 14,16,29,30	GND	-	PK-260(XJ4)
3,4	DC+5V power supply for LCD	-	
6,8,10,12,13, 15,17,18,19	LCD control signal	→	
20,21	AC power supply for LCD	-	
22	DC-10V power supply for LCD	-	
23	DC+15V power supply for LCD	-	
26	DC+15V power supply for LCD backlight	-	
27,28	Light control signal for LCD backlight	→	
24,25	DC+5V	-	

5.3.2 XJ2

No.	Signal Name	Direction	Opposite Side
1	GND	-	Unused
2	DIM	→	
3	DC+5V	-	

5.3.3 XJ3

No.	Signal Name	Direction	Opposite Side
2,20	DC+5V	-	LCD
1,21	GND	-	
25	DC+5V power supply for LCD	-	
26	LCD GND	-	
10,11	AC power supply for LCD	-	
3	DC-10V power supply for LCD	-	
4	DC+15V power supply for LCD	-	
Others	LCD control signal	↔	

5.3.4 XJ4

No.	Signal Name	Direction	Opposite Side
1	DC+5V	-	LCD backlight

5.4 Wireless LAN board (PK-265)

5.4.1 XJ1

No.	Signal Name	Direction	Opposite Side
1	DC+5V	-	PK-260 XJ12
2	GND	-	

5.4.2 XJ2

No.	Signal Name	Direction	Opposite Side
1	TX+	→	PK-260 XJ3
2	TX-	→	
3	RX+	←	
6	RX-	←	
10	LEDR	-	
11	LEDL	-	
4,7,13,14	GND	-	
9,12	DC+3.3V	-	

5.5 Self-service master board (PK-266)

5.5.1 XJ1

No.	Signal Name	Direction	Opposite Side
1	CNVss	-	Unused
2,4,6,10,12,14,	GND	-	
3,9	NC	-	
5	TxD	→	
7	MODE	→	
8	DC+5V	-	
11	RxD	←	
13	RESET	←	

5.5.2 XJ2

No.	Signal Name	Direction	Opposite Side
1	DC+5V	-	PK-260 XJ11
2	TxD	→	
3	RxD	←	
4	P_GND	-	

5.5.3 XJ3/ XJ4

No.	Signal Name	Direction	Opposite Side
1	DC+5V	-	PK-267 XJ1
2	GND	-	
3,4,5,6	Membrane key control signal	↔	

5.5.4 XJ5

No.	Signal Name	Direction	Opposite Side
1,2,3,4,5,6	Key scan KS0 - KS5	→	Membrane key
7,8,9,10,11,12	Key data KD0 - KD5	←	

5.5.5 XJ6/ XJ7

No.	Signal Name	Direction	Opposite Side
1	DC+5V	-	Vibration unit
2	GND	-	

5.6 Self-service master board (PK-267)

5.6.1 XJ1

No.	Signal Name	Direction	Opposite Side
1	DC+5V	-	PK-266 XJ3/XJ4
2	GND	-	
3,4,5,6	Membrane key control signal	↔	

5.6.2 XJ2

No.	Signal Name	Direction	Opposite Side
1,2,3,4,5,6	Key scan KS0 - 5	→	Membrane key
7,8,9,10,11,12	Key data KD0 - 5	←	

5.7 Thermal board (PK-268)

5.7.1 XJ2

No.	Signal Name	Direction	Opposite Side
1	PS (Paper sensor receiver)	←	PK-269 XJ1
2	VPS (Paper sensor receiver)	→	
3,4,11,12, 13,14,25	GND	-	
5	HS (platen position sensor)	←	
6,19,20	DC+24V (Head drive power supply)	-	
7,8,9,16, 17,18	Thermal head control signal	↔	
10	DC+5V	-	
15	TH (Thermistor input signal)	←	
21	MOTOR_A	→	
22	MOTOR_B	→	
23	MOTER_A#	→	
24	MOTER_B#	→	
26	CUTS (Cutter sensor)	←	
27	CUTB (Cutter motor)	→	
28	CUTA (Cutter motor)	→	

5.7.2 XJ4

No.	Signal Name	Direction	Opposite Side
1	CD+24V	-	PK-260 XJ23
2	DC+24V	-	
3	DC+24V	-	
4	GND	-	
5	GND	-	
6	GND	-	

5.7.3 XJ5

No.	Signal Name	Direction	Opposite Side
1	D_Vbus	-	PK-260 XJ25
2	U_Vbus	-	
3	D_D-	↔	
4	U_D-	↔	
5	D_D+	↔	
6	U_D+	↔	
7	D_GND	-	
8	U_GND	-	
9	D_GND	-	
10	U_GND	-	

5.7.4 XJ6

No.	Signal Name	Direction	Opposite Side
1	D_Vbus (Port4)	-	Unused
2	D_Vbus (Port3)	-	
3	D_D- (Port4)	↔	
4	D_D- (Port3)	↔	
5	D_D+ (Port4)	↔	
6	D_D+ (Port3)	↔	
7	D_GND (Port4)	-	
8	D_GND (Port3)	-	
9	Key	-	
10	D_GND (Port3)	-	

5.7.5 XJ1

No.	Signal Name	Direction	Opposite Side
1	SG	-	Unused
2	DC+5V	-	
3,4,5,6,7,8	FROM write signal	↔	

5.8 Thermal connector board (PK-268)

5.8.1 XJ1

No.	Signal Name	Direction	Opposite Side
1	VPS (Paper sensor emitter)	←	PK-268 XJ2
2	PS (Paper sensor receiver)	→	
3,4,11,12, 13,14,26	GND	-	
5,19,20	DC+24V(Head drive power supply)	-	
6	HS (Platen position sensor)	→	
7,8,9,15, 17,18	Thermal head control signal	↔	
10	DC+5V	-	
16	TH (Thermistor input signal)	→	
21	MOTOR_B	←	
22	MOTOR_A	←	
23	MOTER_B#	←	
24	MOTER_A#	←	
26	CUTS (Cutter sensor)	→	
27	CUTB (Cutter motor)	←	
28	CUTA (Cutter motor)	←	

5.8.2 XJ2

No.	Signal Name	Direction	Opposite Side
1	GND	-	Printer unit
2	CUTS (Cutter sensor)	←	
3	CUTB (Cutter motor)	→	
4	CUTA (Cutter motor)	→	

5.8.3 XJ2

No.	Signal Name	Direction	Opposite Side
1	PS (Paper sensor receiver)	←	Printer unit
2	VPS (Paper sensor emitter)	→	
3,4,11,12, 13,14,25	GND	-	
5	HS (Platen position sensor)	←	
6,19,20	DC+24V (Head drive power supply)	-	
7,8,9,16, 17,18	Thermal head control signal	↔	
10	DC+5V	- -	
15	TH (Thermistor input signal)	←	
21	MOTOR_A	→	
22	MOTOR_B	→	
23	MOTER_A#	→	
24	MOTER_B#	→	

5.9 Scale board (PK-999)

5.9.1 XJ2

No.	Signal Name	Direction	Opposite Side
1	D#		PK-260
2	D		
3	DC+12V		
4	GND		
5	FG		
6	Not connected		
7	Not connected		
8	Not connected		

Chapter 6 SETUP mode

6.1 SETUP mode entry

1. Press [Mode] button to enter MENU SELECT screen.

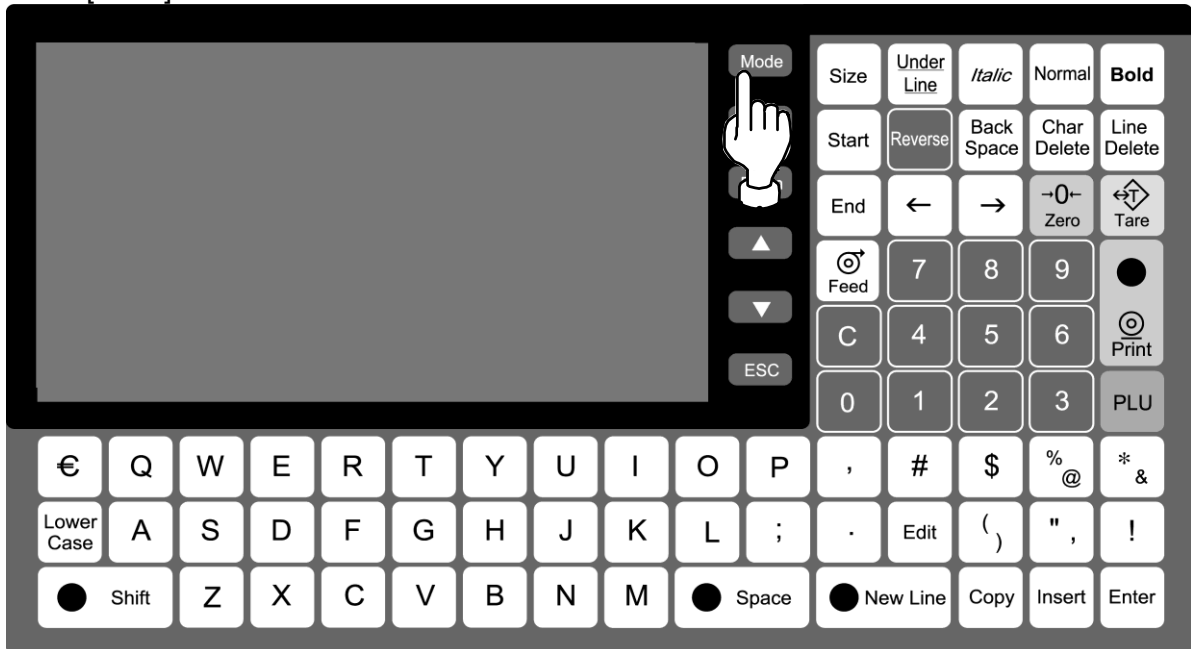

2. Press [SETUP] button on MENU SELECT screen.

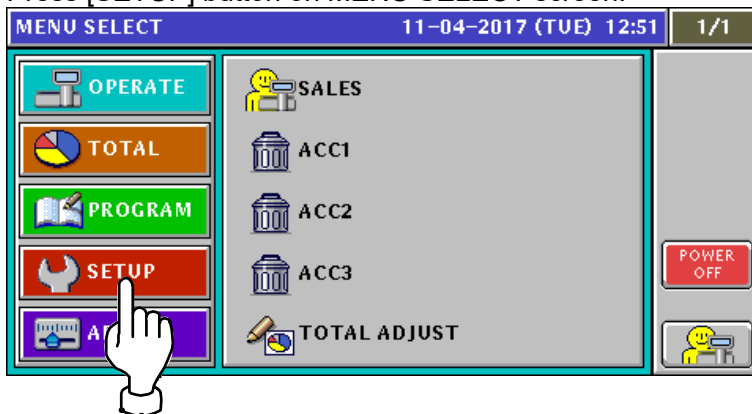

3. The Setup Menu screen appears.
Press [▼] button when changing pages.



4. The next setup menu screen appears.

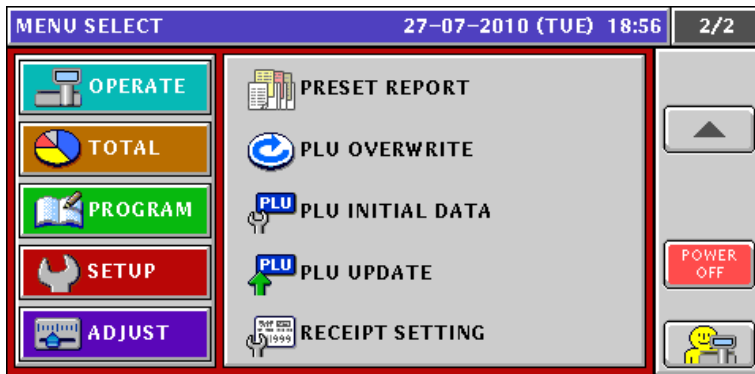

5. Enter "495344" and press [PLU] key on the key sheet to enter Service Mode.

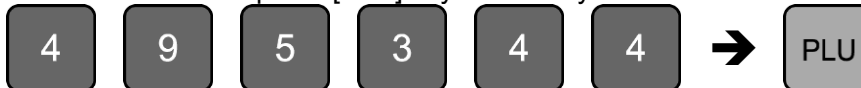

Hidden menus come up on the screen.

Press [▼] or [▲] button when changing the pages.

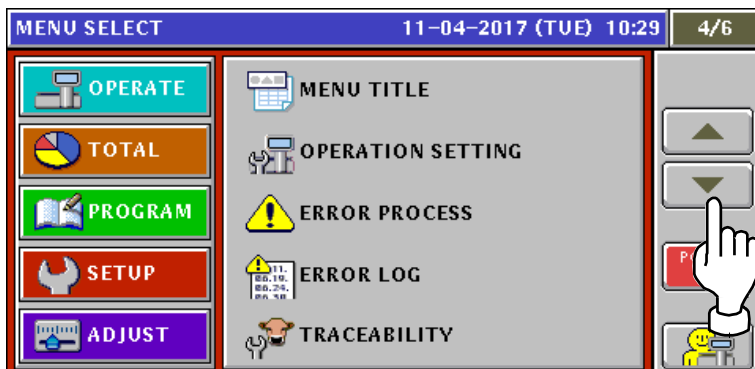
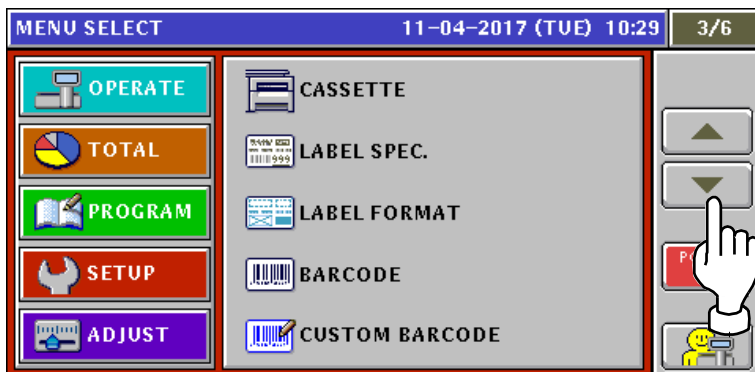
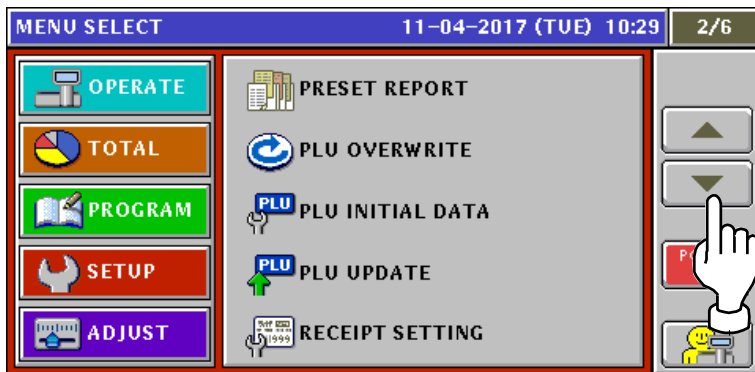

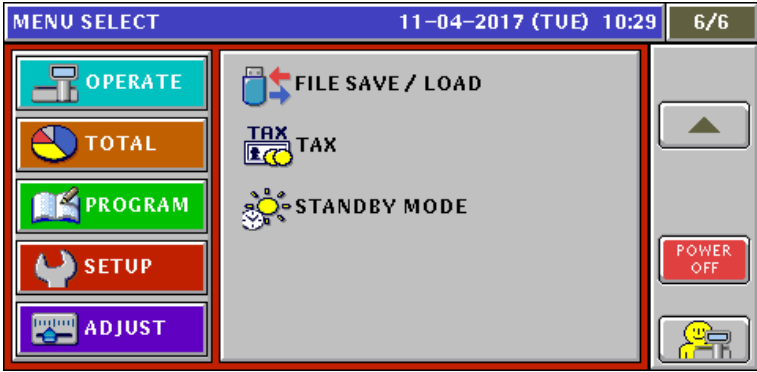
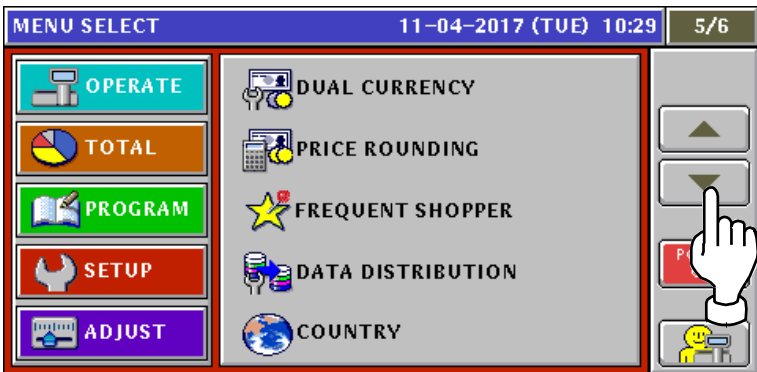

6.2 LABEL setting

1. Press "LABEL SPEC." field on the setup menu screen.

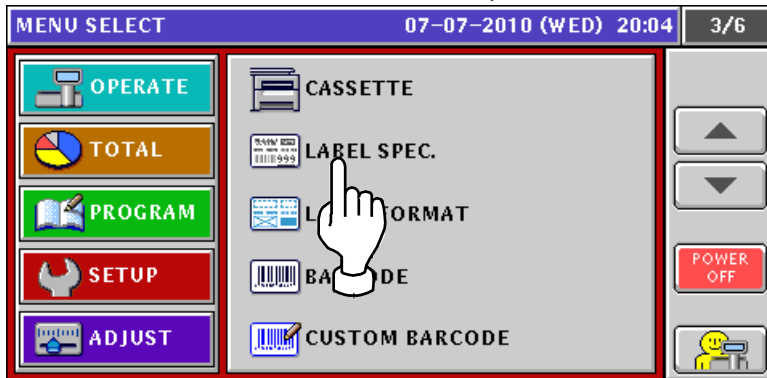

2. The label setup screen appears.
Press to select a desired field for each item.

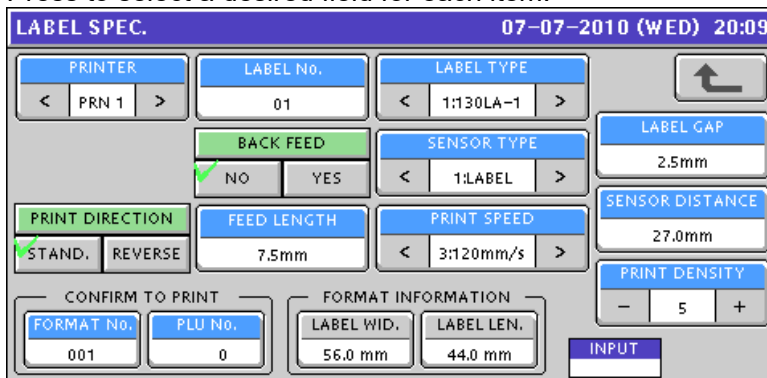

PRINTER	Select a desired printer.
LABEL NO.	Enter a numeric value and press this field.
LABEL TYPE	Select one of the following types: 0: Receipt 1: 130LA-1 3: 150LA-1
LABEL GAP	Enter a numeric value and press this field.
BACK FEED	Press to select either "NO" or "YES".
SENSOR TYPE	Select one of the following types: 0: NO USE 1: LABEL
SENSOR DISTANCE	Enter a numeric value and press this field.
PRINT DIRECTION	Press to select either "STAND" or "REVERSE".
FEED LENGTH	Enter a numeric value and press this field.
PRINT SPEED	Select one of the following print speeds: 1: 80mm/sec 2: 100mm/sec 3: 120mm/sec
PRINT DENSITY	Select a desired print density level (0 to 9).
FORMAT NO.	Enter a numeric value and press this field.
PLU NO.	Enter a numeric value and press this field.

6.3 LABEL FORMAT setting

1. Press "LABEL FORMAT" field on the setup menu screen.

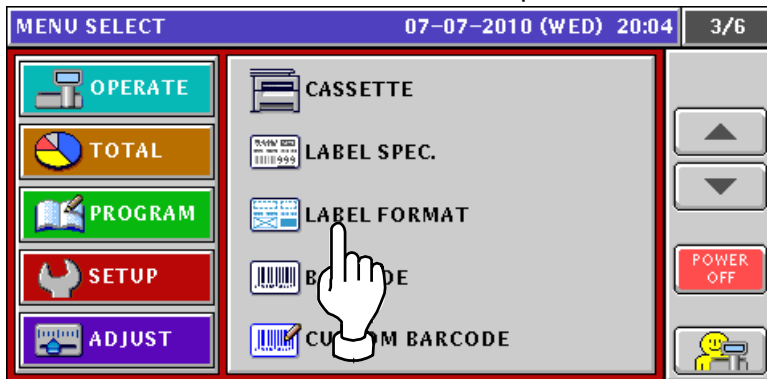

2. LABEL FORMAT LIST screen appears.

The screenshot shows the 'LABEL FORMAT LIST' screen with a date and time of JUN-14-2007(THU) 22:37 and page 1/7. It displays a table with 8 rows and 4 columns: No., DESCRIPTION, WIDTH, and HEIGHT. The first row is highlighted in yellow.

No.	DESCRIPTION	WIDTH	HEIGHT
1	LABEL FORMAT 1	56.0 mm	44.0 mm
2		56.0 mm	85.0 mm
3		56.0 mm	59.0 mm
4		56.0 mm	73.0 mm
5		56.0 mm	59.0 mm
6		56.0 mm	84.0 mm
7		56.0 mm	146.0 mm
8		56.0 mm	50.0 mm

On the right side of the table, there are navigation buttons: a back arrow, a down arrow, 'PRINT CONTROL', 'DETAIL', and 'DELETE'.

3. Press to select a desired format field and press [DETAIL] button.

This screenshot is identical to the previous one, but with a hand icon pointing to the second row (No. 2) in the table and another hand icon pointing to the 'DETAIL' button on the right.

4. LABEL FORMAT (BASIC) screen appears.
Refer to steps 6 through 16 in section 6.2 for further procedures.

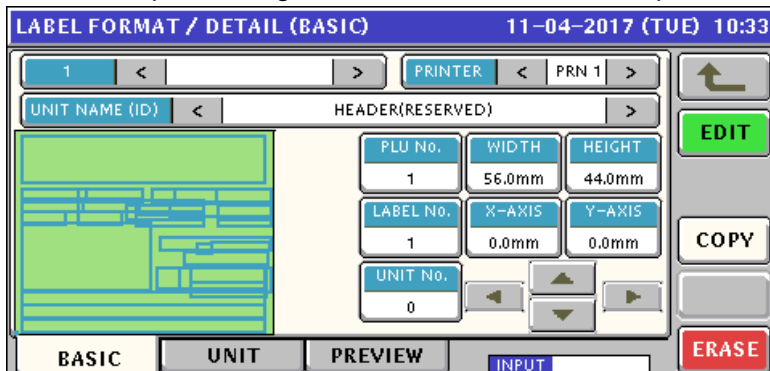

- To change existing format data, press to select a desired field, and press [PRINT CONTROL] button.

EXAMPLE "LABEL FORMAT 2"

LABEL FORMAT LIST				JUN-14-2007(THU) 22:39		1/7
No.	DESCRIPTION	WIDTH	HEIGHT			
1	LABEL FORMAT 1	56.0 mm	44.0 mm			
2	LABEL FORMAT 2	56.0 mm	85.0 mm			
3		56.0 mm	59.0 mm			
4		56.0 mm	73.0 mm			
5		56.0 mm	59.0 mm			
6		56.0 mm	84.0 mm			
7		56.0 mm	146.0 mm			
8		56.0 mm	50.0 mm			

Navigation buttons: Up arrow, Down arrow, PRINT CONTROL, DE (green), DE (red)

- Press to select a desired field for each print-related item on the screen.

FORMAT(PRINT CONTROL)						JUN-14-2007(THU) 22:39	
M PRICE PRINT			REPACK MARK PRINT				
BARCODE ONLY	BAR+2LINE	2LINE+M PRI	NO	YES			
5X7 PRINT							
NO PRN	CALL No.	TARE WEIGHT	STORE No.	PACK DATE CD			
REGISTER CODE PRINT							
REGI. CODE	SHOP No.	PACK DATE CD					
PRINTING		POSITION					

Press [POSITION] tab and press to select a desired field for each control-related item.

FORMAT(PRINT CONTROL)						JUN-14-2007(THU) 22:39	
EXTRA MSG1 PRINT POSITION							
FORMAT	PRODUCT NAME UNDER	RAW MATERIAL UNDER	PRODUCT NAME UPPER				
REGISTER CODE PRINT POSITION			POP NAME PRINT POSITION				
FORMAT	PRODUCT NAME LEFT	PRODUCT NAME RIGHT	FORMAT	PRODUCT NAME LEFT	PRODUCT NAME RIGHT		
ORIGIN PRINT POSITION							
FORMAT	PRODUCT NAME LEFT	PRODUCT NAME RIGHT	PRODUCT NAME UPPER	PRODUCT NAME UNDER			
PRINTING		POSITION					

Press Return button.

FORMAT(PRINT CONTROL)						JUN-14-2007(THU) 22:39	
EXTRA MSG1 PRINT POSITION							
FORMAT	PRODUCT NAME UNDER	RAW MATERIAL UNDER	PRODUCT NAME UPPER				
REGISTER CODE PRINT POSITION			POP NAME PRINT POSITION				
FORMAT	PRODUCT NAME LEFT	PRODUCT NAME RIGHT	FORMAT	PRODUCT NAME LEFT	PRODUCT NAME RIGHT		
ORIGIN PRINT POSITION							
FORMAT	PRODUCT NAME LEFT	PRODUCT NAME RIGHT	PRODUCT NAME UPPER	PRODUCT NAME UNDER			
PRINTING		POSITION					

6.4 BARCODE setting

1. Press "BARCODE" field on the setup menu screen.

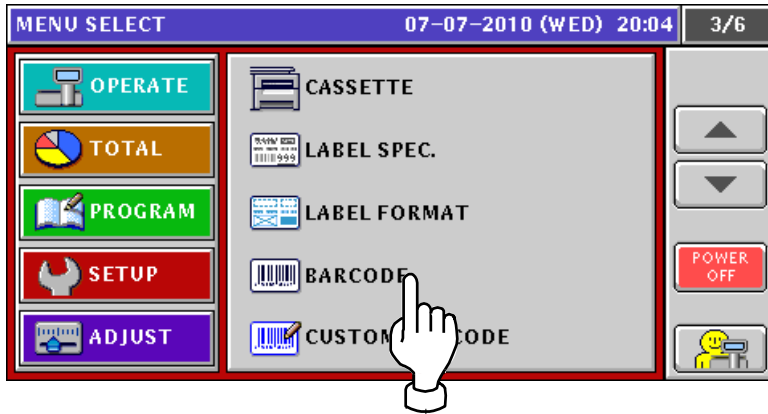

2. Ensure that BARCODE (POS FLAG) screen is displayed.
If not displayed, press [POS FLAG] tab.
Enter a desired numeric value for each item and press the corresponding field.

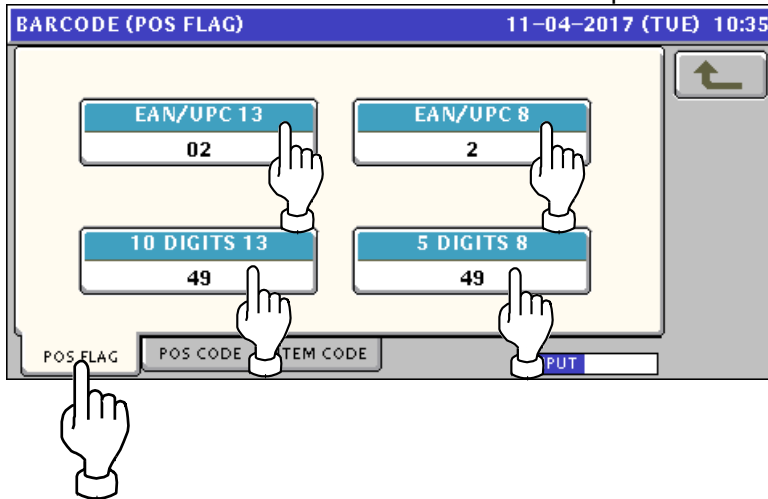

3. Press [POS CODE] tab to display BARCODE (POS CODE) screen.
Then, select a desired POS code type by using [>] and [<] buttons.

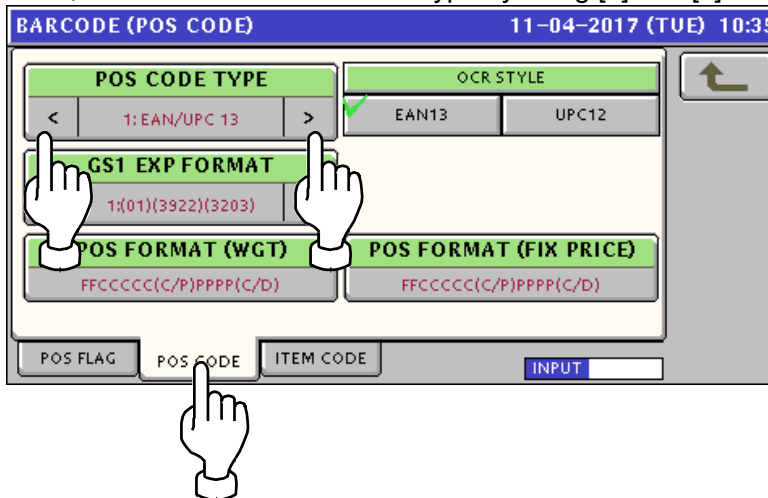

POS CODE TYPE	Select one of the following code types:
	1: EAN/UPC 13
	2: EAN/UPC 8
	3: 10 DIGITS 13
	4: 5 DIGITS 8
	5: GS 1
	6: GS 1 ST
	7: GS 1 STO
	8: GS 1 LIMITED
	9: GS 1 EXPANDED
10: ITF	

4. Press [POS FORMAT (WGT)] button to display POS FORMAT screen.

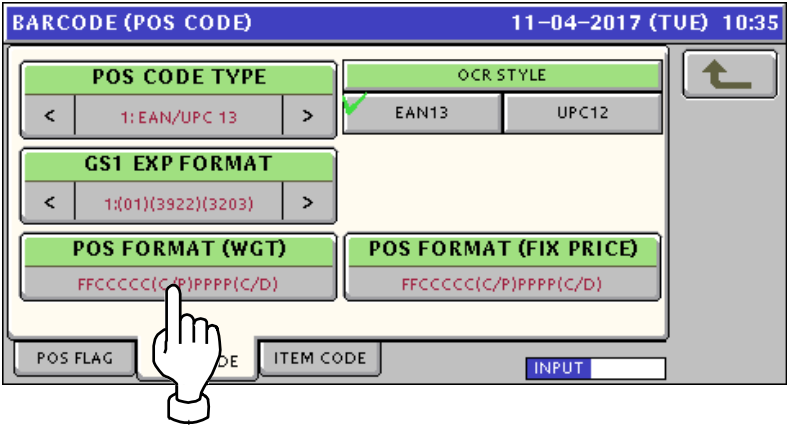

The following Barcode Format list screen appears. Press to select a desired field to determine the barcode format. Press either [▼] or [▲] button to change the pages.

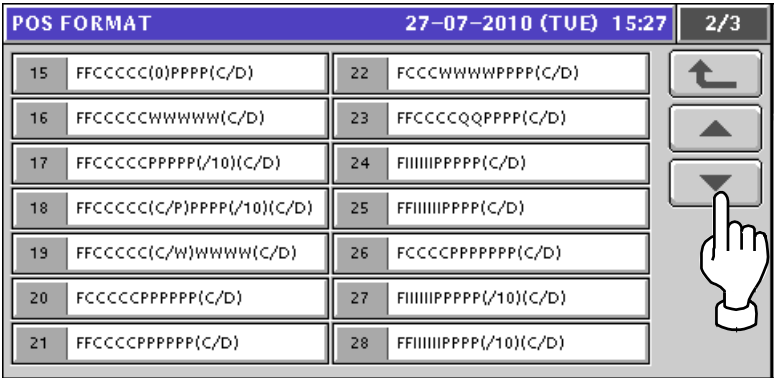
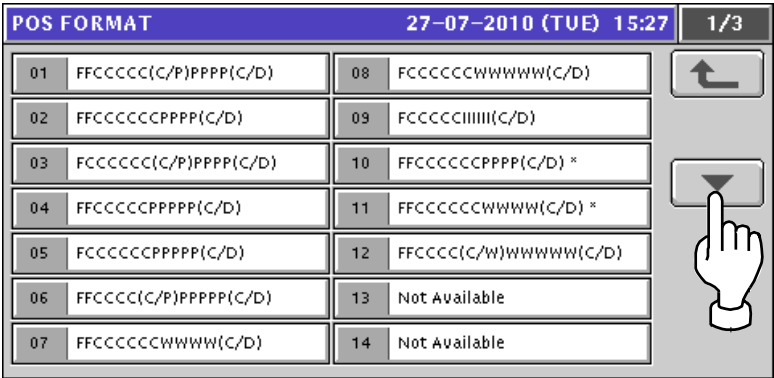

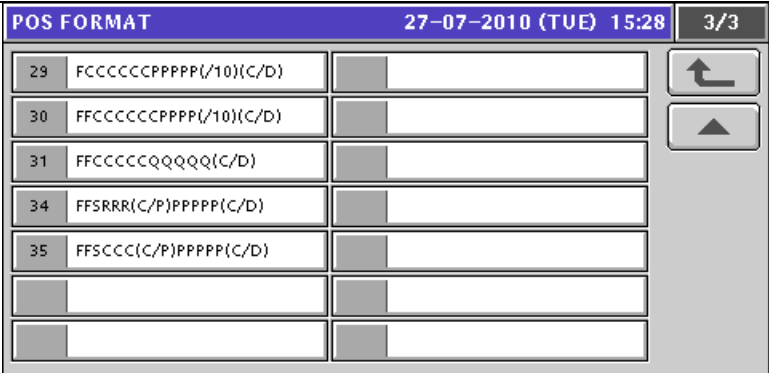

5. Select a desired GS1 expanded format by using [>] and [<] buttons.

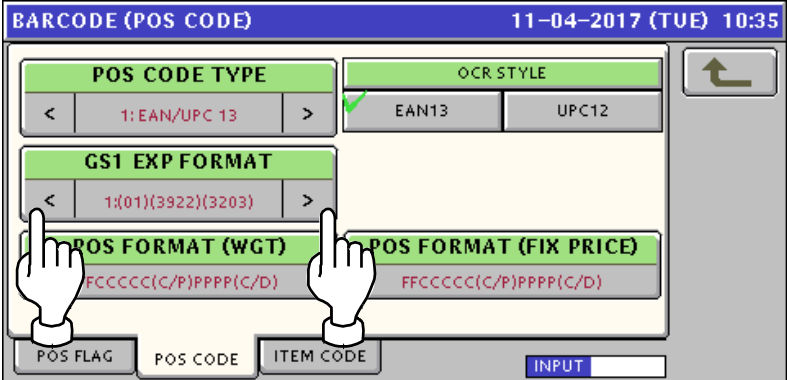

GS1 EXPANDED FORMAT	Select one of the following GS1 expanded formats:
	1: (01) (3922) (3203)
	2: (01) (3922) (3203) (15)

6. Press [ITEM CODE] tab to display BARCODE (ITEM CODE) screen. Press to select the code digits for each digit set.

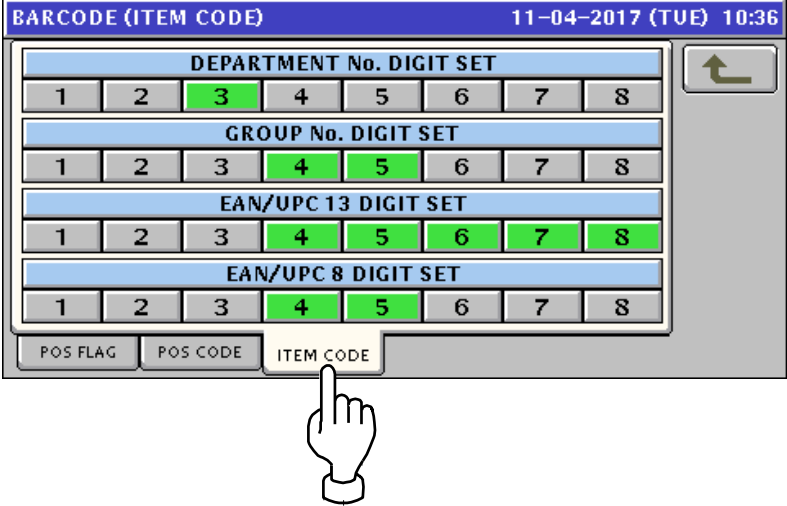

7. Press Return button to return to the Menu Select screen.

BARCODE (ITEM CODE)								11-04-2017 (TUE) 10:36	
DEPARTMENT No. DIGIT SET									
1	2	3	4	5	6	7	8		
GROUP No. DIGIT SET									
1	2	3	4	5	6	7	8		
EAN/UPC 13 DIGIT SET									
1	2	3	4	5	6	7	8		
EAN/UPC 8 DIGIT SET									
1	2	3	4	5	6	7	8		
POS FLAG		POS CODE		ITEM CODE					

6.5 CUSTOM BARCODE setting

1. Press "CUSTOM BARCODE" field on the screen.

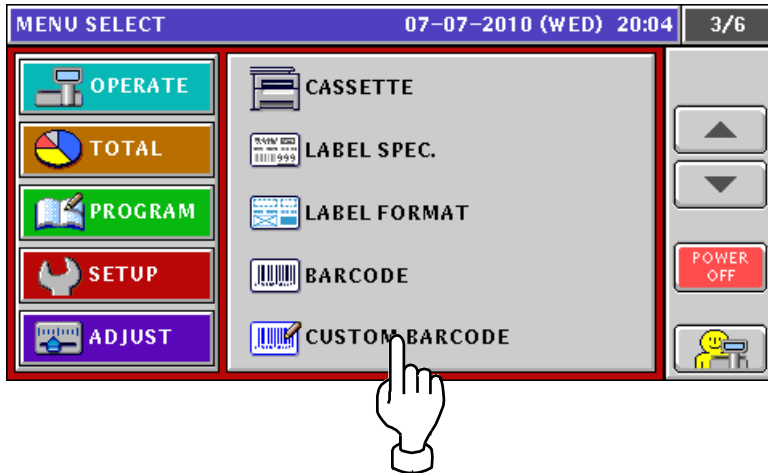

2. CUSTOM BARCODE screen appears.

Press [NEW] button on the screen.

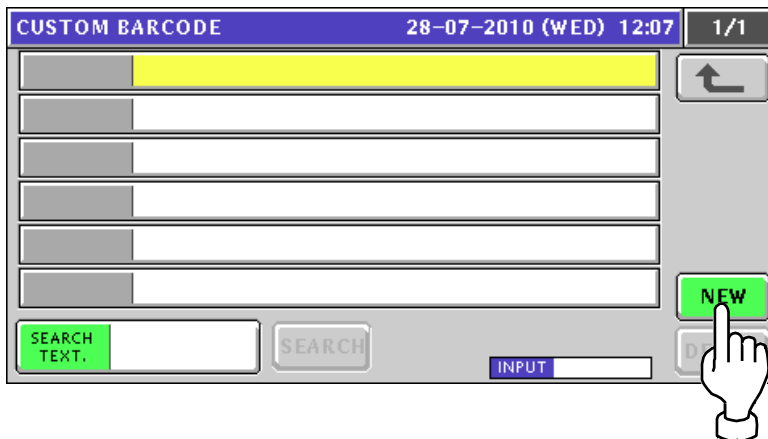

3. The following confirmation screen appears.

Press [ENTER] button on the screen for confirmation.

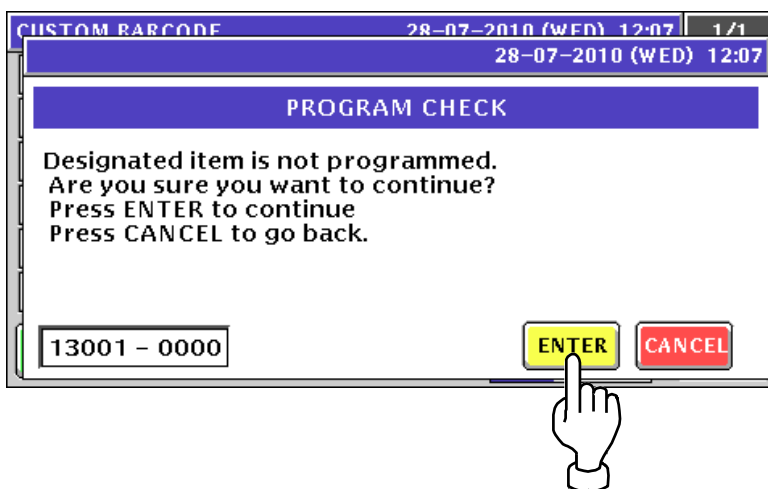

4. CUSTOM BARCODE (BASIC) screen appears.

Press [EDIT] button on the screen.

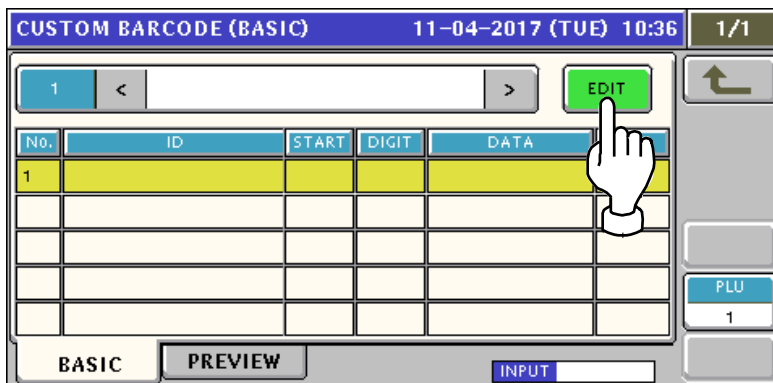

5. The following text edit screen appears.

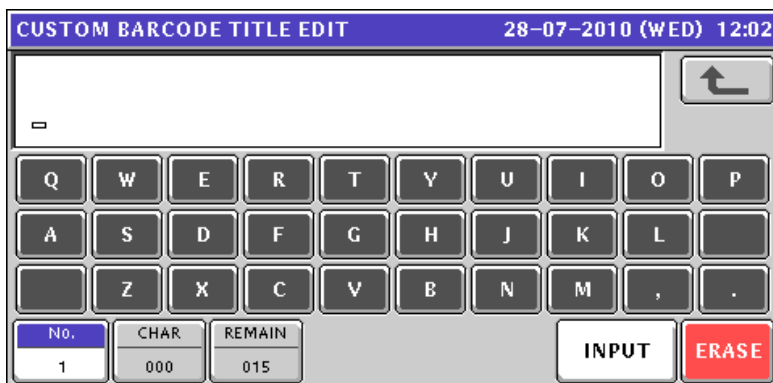

Enter a desired text according to the procedure described in Appendix “Text editing”.

EXAMPLE “CUST BARCODE 1”

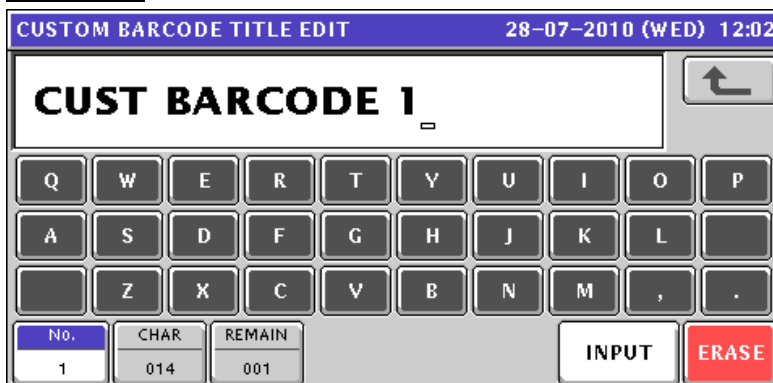

Press [ESC] key on the key sheet.



6. CUSTOM BARCODE (BASIC) screen with edited title name appears. Then, press the selected (highlighted) field on the screen.

CUSTOM BARCODE (BASIC)						11-04-2017 (TUE) 10:38	1/1
1	CUST BARCODE				EDIT		
No.	ID	START	DIGIT	DATA	CTRL		
1	PLU No.	1	0:ALL	00000001	0:NONE		
2							
BASIC		PREVIEW		INPUT		ERASE	

The following ID list screens appear. Press either [▼] or [▲] button to change the pages.

CUSTOM BARCODE ID LIST				11-04-2017 (TUE) 10:38	1/3
000	RESERVED	015	UNIT PRICE		
001	PRE PRINT	016	WEIGHT		
010	PLU No.	018	QTY DATA		
011	PACK DATE	01B	MD PRICE		
012	USE-BY DATE	021	SUBTOTAL		
013	SELL-BY DATE	02E	RECEIPT No.		
014	PRICE	02F	MACHINE No.		

CUSTOM BARCODE ID LIST				11-04-2017 (TUE) 10:38	2/3
035	TOTAL QUANTITY	09A	POINTS		
036	TOTAL WEIGHT	0EA	OPERATOR No.		
037	TOTAL PRICE	0EC	WEIGHT(USA)		
048	ITEM CODE	10B	GROUP		
049	POS FLAG	180	RECEIPT CODE		
04A	POS CODE	181	Check Price(c/p)		
055	NETWORK No.	1FF	C/D		

CUSTOM BARCODE ID LIST				11-04-2017 (TUE) 10:38	3/3
200	PCS DATA				
201	DEPARTMENT				
230	BAG No.				

7. Press to select a desired item on the list.

EXAMPLE "PLU No."

CUSTOM BARCODE ID LIST		11-04-2017 (TUE) 10:38		1/3
000	RESERVED	015	UNIT PRICE	↑
001	PRE PRINT	016	WEIGHT	
010	PLU No.	018	QTY DATA	↓
011	PACK DATE	01B	MD PRICE	
012	USE-BY DATE	021	SUBTOTAL	
013	SELL-BY DATE	02E	RECEIPT No.	
014	PRICE	02F	MACHINE No.	

Then, the following screen appears.

To continue further registration, press to select a desired field on the screen.

EXAMPLE "2"

CUSTOM BARCODE (BASIC)		11-04-2017 (TUE) 10:38		1/1	
1	<	CUST BARCODE	>	EDIT	
No.	ID	START	DIGIT	DATA	CTRL
1	PLU No.	1	0:ALL	00000001	0:NONE
2					
BASIC		PREVIEW		INPUT	ERASE

Press to select a next desired item on the list.

CUSTOM BARCODE ID LIST		11-04-2017 (TUE) 10:38		1/3
000	RESERVED	015	UNIT PRICE	↑
001	PRE PRINT	016	WEIGHT	
010	PLU No.	018	QTY DATA	↓
011	PACK DATE	01B	MD PRICE	
012	USE-BY DATE	021	SUBTOTAL	
013	SELL-BY DATE	02E	RECEIPT No.	
014	PRICE	02F	MACHINE No.	

To end registration, press Return key on the screen.

CUSTOM BARCODE (BASIC)		11-04-2017 (TUE) 10:39		1/1	
1	<	CUST BARCODE	>	EDIT	
No.	ID	START	DIGIT	DATA	CTRL
1	PLU No.	1	0:ALL	00000001	0:NONE
2	PACK DATE	1	0:ALL	20170411	0:NONE
3					
BASIC		PREVIEW		INPUT	ERASE

6.6 MENU TITLE editing

1. Press "MENU TITLE" field on the screen.

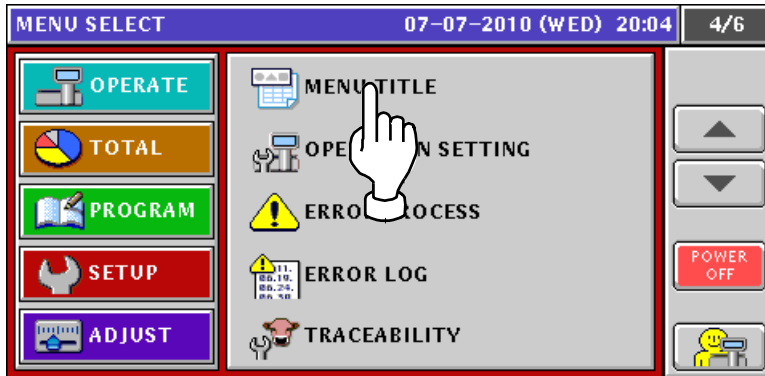

2. MENU TITLE (OPERATE) screen appears.
Press either [▼] or [▲] button to change the pages.

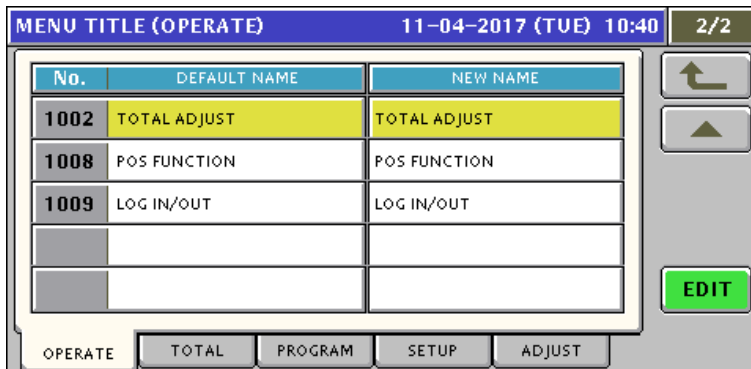
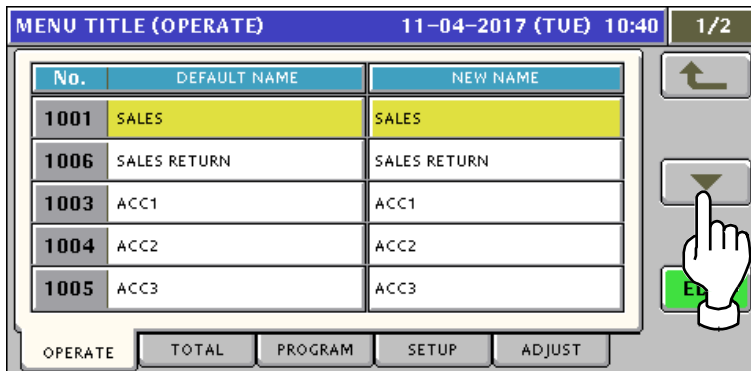

Press to select a desired field on the screen, and press [EDIT] button.

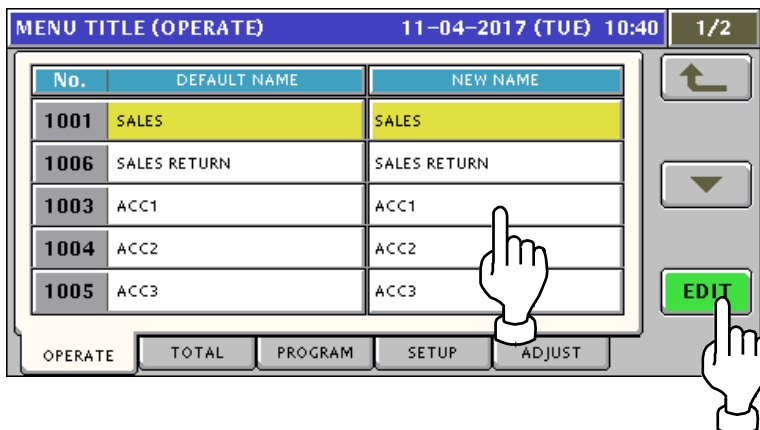

3. The following text edit screen appears.

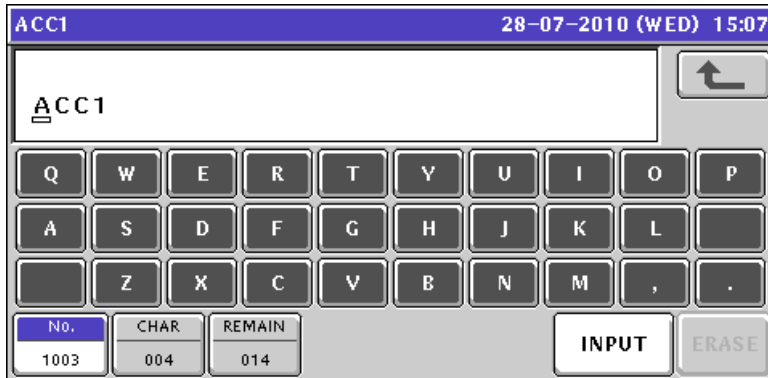

Enter a desired text according to the procedure described in Appendix "Text editing".

EXAMPLE "ACCUMULATION 1"

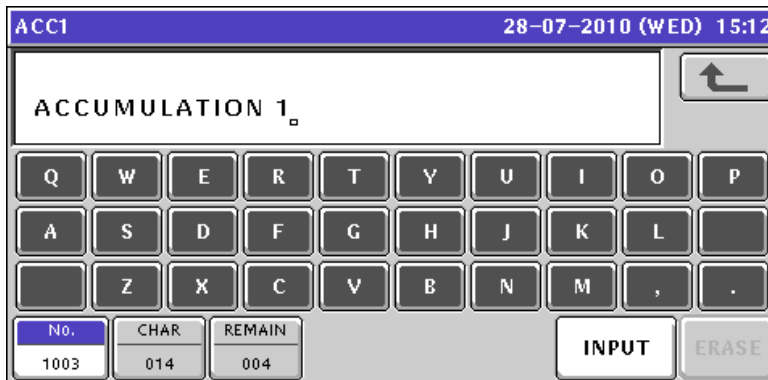

Press [ESC] key on the key sheet.



The following confirmation screen appears.
Press [SAVE] button on the screen for confirmation.

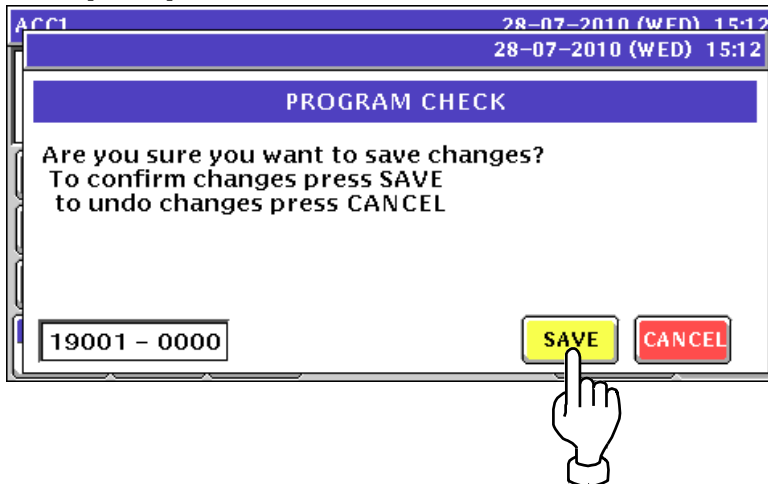

MENU TITLE (OPERATE)			11-04-2017 (TUE) 10:56	1/2
No.	DEFAULT NAME	NEW NAME		
1001	SALES	SALES		
1006	SALES RETURN	SALES RETURN		
1003	ACC1	ACCUMULATION 1		
1004	ACC2	ACC2		
1005	ACC3	ACC3		

OPERATE TOTAL PROGRAM SETUP ADJUST

EDIT

- 4** Press [TOTAL] tab on the screen.
Press either [▼] or [▲] button to change the pages.

MENU TITLE (TOTAL)			11-04-2017 (TUE) 10:56	1/3
No.	DEFAULT NAME	NEW NAME		
2001	SALES DAILY TOTAL	SALES DAILY TOTAL		
2002	SALES WEEKLY TOTAL	SALES WEEKLY TOTAL		
2003	SALES CUM. TOTAL	SALES CUM. TOTAL		
2004	VIRTUAL RECEIPT	VIRTUAL RECEIPT		
2005	PROD. DAILY TOTAL	PROD. DAILY TOTAL		

OPERATE TOTAL PROGRAM SETUP ADJUST

EDIT



MENU TITLE (TOTAL)			11-04-2017 (TUE) 10:56	2/3
No.	DEFAULT NAME	NEW NAME		
2006	PROD. WEEKLY TOTAL	PROD. WEEKLY TOTAL		
2007	PROD. CUM. TOTAL	PROD. CUM. TOTAL		
2008	TRACEABILITY TOTAL	TRACEABILITY TOTAL		
2009	PRESET REPORT	PRESET REPORT		
2015	POS REPORT	POS REPORT		

OPERATE TOTAL PROGRAM SETUP ADJUST

EDIT

MENU TITLE (TOTAL)			11-04-2017 (TUE) 10:56	3/3
No.	DEFAULT NAME	NEW NAME		
2016	DRAWER REPORT	DRAWER REPORT		
2010	TOTAL CLEAR	TOTAL CLEAR		

OPERATE TOTAL PROGRAM SETUP ADJUST

EDIT

5. Press [PROGRAM] tab on the screen.
Press either [▼] or [▲] button to change the pages.

MENU TITLE (PROGRAM) 11-04-2017 (TUE) 10:56 1/8

No.	DEFAULT NAME	NEW NAME
3001	PLU	PLU
3002	CAMPAIGN	CAMPAIGN
3006	OPERATORS	OPERATORS
3004	PRESET KEY	PRESET KEY
3005	AD MSG.	AD MSG.

OPERATE TOTAL PROGRAM SETUP ADJUST

MENU TITLE (PROGRAM) 11-04-2017 (TUE) 10:56 2/8

No.	DEFAULT NAME	NEW NAME
3003	STORE	STORE
3012	DEPARTMENT	DEPARTMENT
3013	GROUP	GROUP
3019	COOKING TIME	COOKING TIME
3007	NUTRITION	NUTRITION

OPERATE TOTAL PROGRAM SETUP ADJUST

MENU TITLE (PROGRAM) 11-04-2017 (TUE) 10:56 3/8

No.	DEFAULT NAME	NEW NAME
3008	EXTRA MSG. 1	EXTRA MSG. 1
3009	EXTRA MSG. 2	EXTRA MSG. 2
3010	EXTRA MSG. 3	EXTRA MSG. 3
3011	COUPON MSG.	COUPON MSG.
3014	POP MSG.	POP MSG.

OPERATE TOTAL PROGRAM SETUP ADJUST

MENU TITLE (PROGRAM) 11-04-2017 (TUE) 10:57 4/8

No.	DEFAULT NAME	NEW NAME
3038	DISBURSEMENT TYPE	DISBURSEMENT TYPE
3016	SCHEME TABLE	SCHEME TABLE
3017	GEN TABLE	GEN TABLE
3018	LOOKUP TABLE	LOOKUP TABLE
3036	MINCE TRACEABILITY	MINCE TRACEABILITY

OPERATE TOTAL PROGRAM SETUP ADJUST

MENU TITLE (PROGRAM)			11-04-2017 (TUE) 10:57	5/8
No.	DEFAULT NAME	NEW NAME		
3035	FIX PRICE SYMBOL	FIX PRICE SYMBOL		
3020	FREE MSG. 1	FREE MSG. 1		
3021	FREE MSG. 2	FREE MSG. 2		
3022	FREE MSG. 3	FREE MSG. 3		
3023	FREE MSG. 4	FREE MSG. 4		

OPERATE TOTAL PROGRAM SETUP ADJUST

EDIT

MENU TITLE (PROGRAM)			11-04-2017 (TUE) 10:57	6/8
No.	DEFAULT NAME	NEW NAME		
3024	FREE MSG. 5	FREE MSG. 5		
3025	FREE MSG. 6	FREE MSG. 6		
3026	FREE MSG. 7	FREE MSG. 7		
3027	FREE MSG. 8	FREE MSG. 8		
3028	FREE MSG. 9	FREE MSG. 9		

OPERATE TOTAL PROGRAM SETUP ADJUST

EDIT

MENU TITLE (PROGRAM)			11-04-2017 (TUE) 10:57	7/8
No.	DEFAULT NAME	NEW NAME		
3029	FREE MSG. 10	FREE MSG. 10		
3030	FREE MSG. 11	FREE MSG. 11		
3031	FREE MSG. 12	FREE MSG. 12		
3032	FREE MSG. 13	FREE MSG. 13		
3033	FREE MSG. 14	FREE MSG. 14		

OPERATE TOTAL PROGRAM SETUP ADJUST

EDIT

MENU TITLE (PROGRAM)			11-04-2017 (TUE) 10:57	8/8
No.	DEFAULT NAME	NEW NAME		
3034	FREE MSG. 15	FREE MSG. 15		
3015	CHECK LABEL	CHECK LABEL		
3039	STAMP PRICE	STAMP PRICE		
3040	NUTRITION TEXT	NUTRITION TEXT		

OPERATE TOTAL PROGRAM SETUP ADJUST

EDIT

6. Press [SETUP] tab on the screen.
Press either [▼] or [▲] button to change the pages.

MENU TITLE (SETUP) 11-04-2017 (TUE) 10:57 1/3

No.	DEFAULT NAME	NEW NAME
4002	MACHINE No.(COMMS)	MACHINE No.(COMMS)
4001	SALES MODE	SALES MODE
4003	PASSWORD	PASSWORD
4004	KEY LOCK	KEY LOCK
4005	DATA STORAGE	DATA STORAGE

OPERATE TOTAL PROGRAM **SETUP** ADJUST

MENU TITLE (SETUP) 11-04-2017 (TUE) 10:57 2/3

No.	DEFAULT NAME	NEW NAME
4026	PRESET REPORT	PRESET REPORT
4006	PLU OVERWRITE	PLU OVERWRITE
4007	PLU INITIAL DATA	PLU INITIAL DATA
4008	PLU UPDATE	PLU UPDATE
4021	RECEIPT SETTING	RECEIPT SETTING

OPERATE TOTAL PROGRAM **SETUP** ADJUST

MENU TITLE (SETUP) 11-04-2017 (TUE) 10:57 3/3

No.	DEFAULT NAME	NEW NAME
4029	TAX	TAX

OPERATE TOTAL PROGRAM **SETUP** ADJUST

EDIT

7. Press [ADJUST] tab on the screen.
Press either [▼] or [▲] button to change the pages.

MENU TITLE (ADJUST) 11-04-2017 (TUE) 10:57 1/1

No.	DEFAULT NAME	NEW NAME
5001	DATE TIME	DATE TIME
5002	TOUCH SCREEN	TOUCH SCREEN
5003	DISPLAY CHECK	DISPLAY CHECK

OPERATE TOTAL PROGRAM **SETUP** ADJUST

EDIT

6.7 OPERATION SETTING

1. Press "OPERATION SETTING" field on the screen.



2. OPERATION SETTING (CALL) screen appears. Then, press to select a desired field for each item.

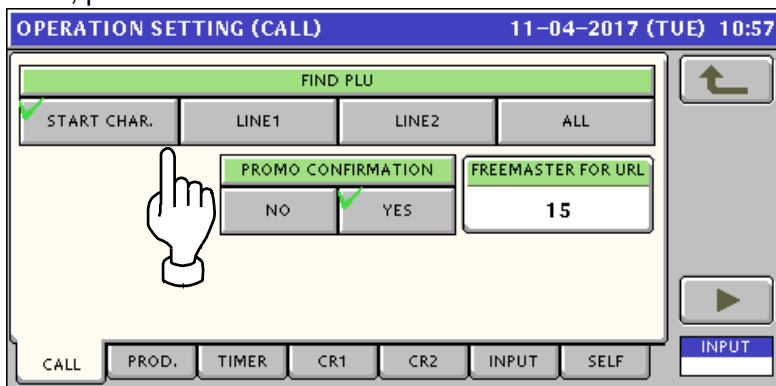

3. Press [PROD.] tab on the screen. OPERATION SETTING (PRODUCTION) screen appears. Then, press to select a desired field for each item.

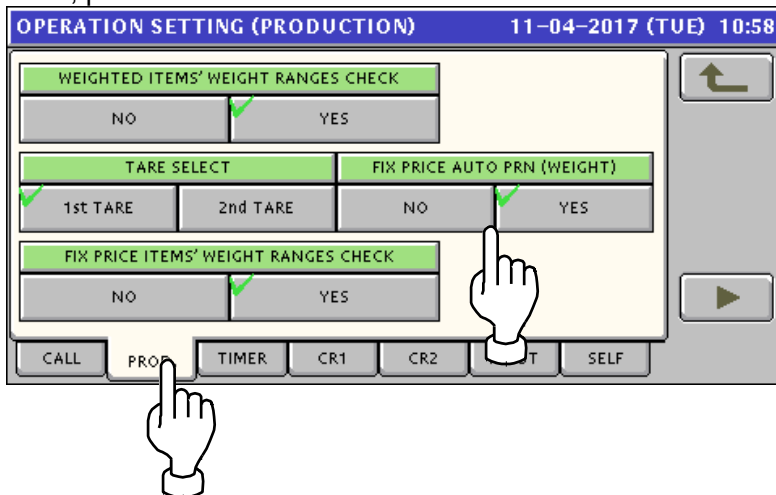

4. Press [TIMER] tab on the screen.
OPERATION SETTING (TIMER) screen appears.
Then, enter a desired numeric value for each item and press the corresponding field.

5. Press [CR1] tab on the screen.
OPERATION SETTING (CR1) screen appears.

6. Press [CR2] tab on the screen.
OPERATION SETTING (CR2) screen appears.

7. Press [INPUT] tab on the screen.
OPERATION SETTING (INPUT) screen appears.

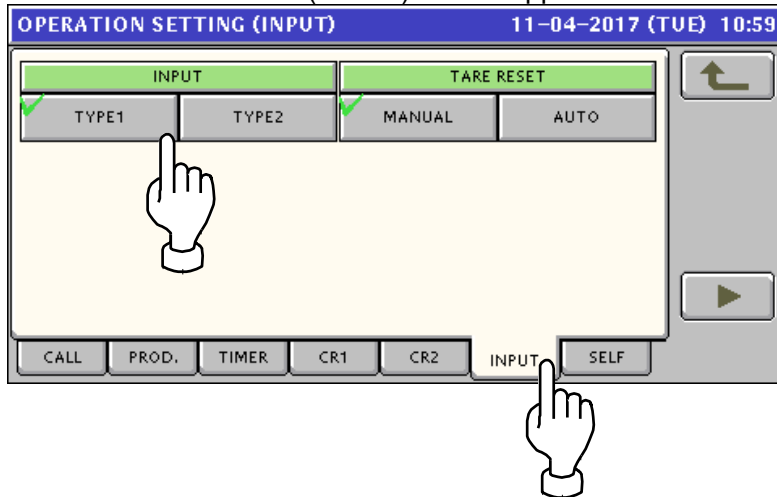

8. Press [SELF] tab on the screen.
OPERATION SETTING (SELF) screen appears.

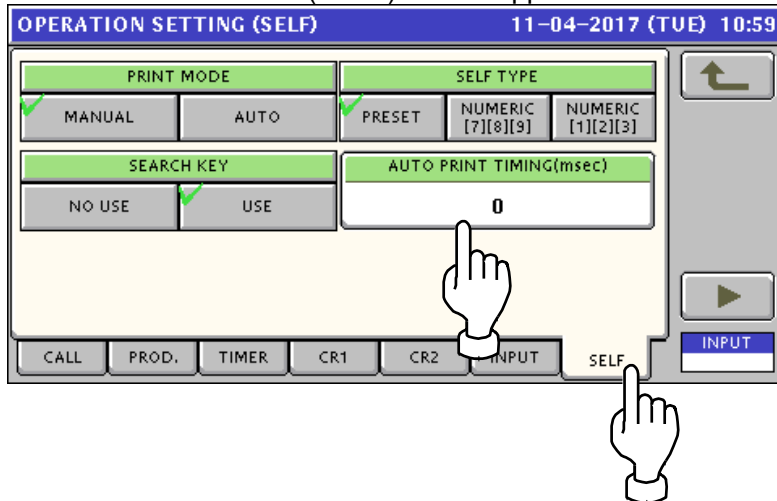

6.8 ERROR PROCESS setting

1. Press "ERROR PROCESS" field on the screen.

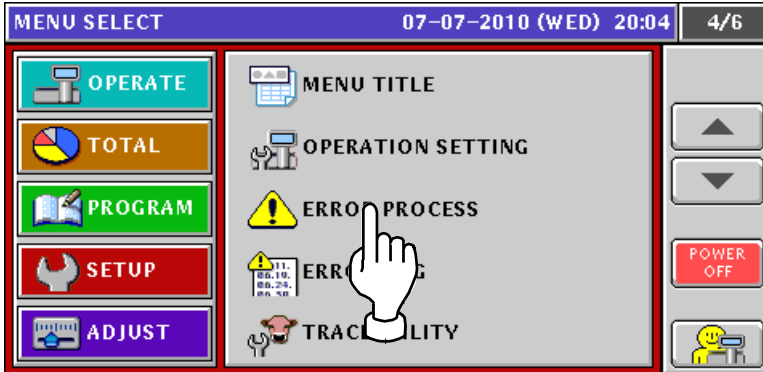

2. ERROR PROCESS (ISSUE) screen appears.
Press to select a desired field for each item.

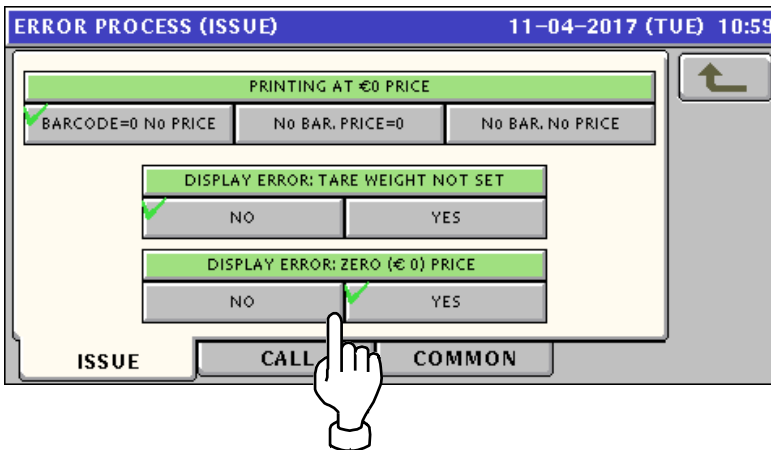

3. Press "CALL" tab to display ERROR PROCESS (CALL) screen.
Then, press to select a desired field.

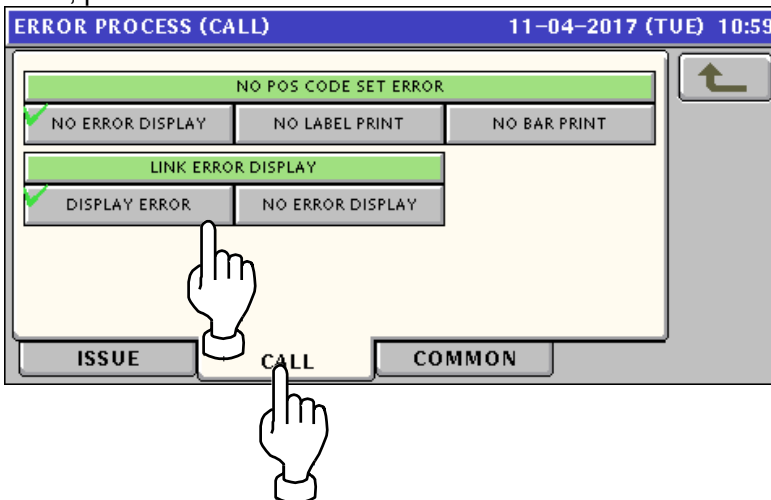

4. Select "COMMON" tab to display ERROR PROCESS (COMMON) screen. Then, press to select a desired field.

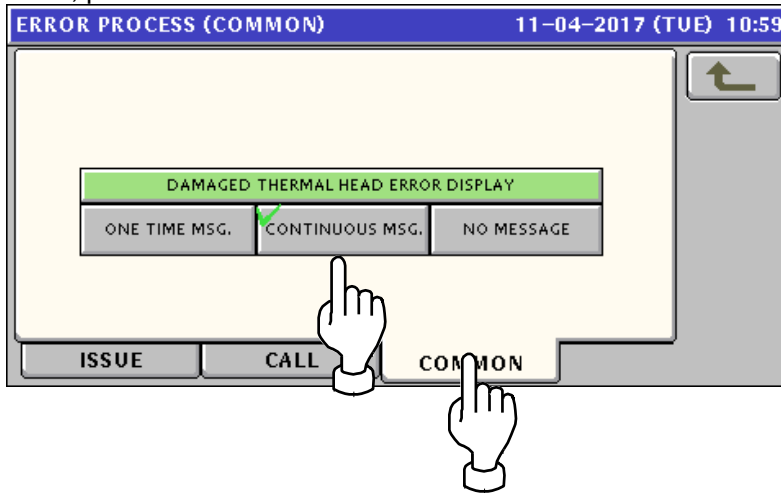

6.9 ERROR LOG display

1. Press "ERROR LOG" field on the screen.

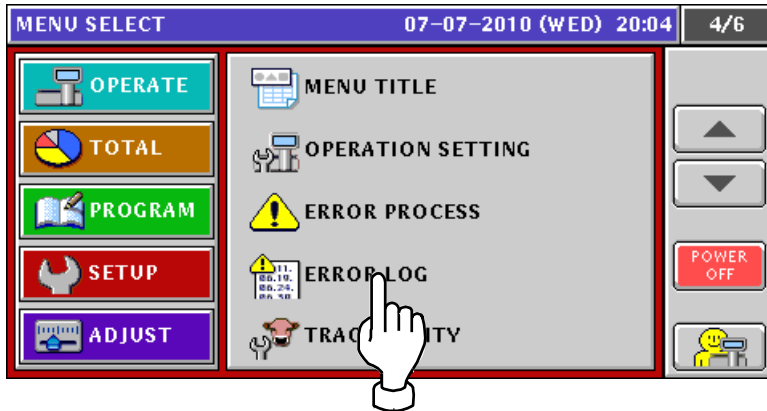

2. ERROR LOG (DISPLAY) screen appears.
Press [▼] or [▲] button when changing the pages.

The screenshot shows the 'ERROR LOG (DISPLAY)' screen with a purple header bar displaying '27-07-2010 (TUE) 17:15' and '1/2'. The table below shows error logs:

DATE/TIME	ERROR No.	PLU	ERROR DESCRIPTION
07/27 09:09	0361-0000	0	POWER IS ON
07/26 21:53	0396-0000	0	NO USB MEMORY
07/26 21:52	0396-0000	0	NO USB MEMORY
07/26 21:52	0396-0000	0	NO USB MEMORY
07/26 21:02	0361-0000	0	POWER IS ON
07/15 17:05	0361-0000	0	POWER IS ON
07/08 10:22	0710-0000	0	NO LABEL FOR PRINTER 1

At the bottom, there is a 'DISPLAY' button, an 'INPUT' field, and an 'ERASE' button. A hand cursor is pointing to the downward arrow button on the right side.

The screenshot shows the 'ERROR LOG (DISPLAY)' screen with a purple header bar displaying '27-07-2010 (TUE) 17:15' and '2/2'. The table below shows error logs:

DATE/TIME	ERROR No.	PLU	ERROR DESCRIPTION
07/08 10:22	0202-0000	0	PLU MASTER IS NOT PROGRAMMED
07/08 10:20	0361-0000	0	POWER IS ON
07/07 19:57	0361-0000	0	POWER IS ON
07/07 15:20	0396-0000	0	NO USB MEMORY
07/07 15:08	0361-0000	0	POWER IS ON
07/06 14:27	0361-0000	0	POWER IS ON
07/06 14:00	0361-0000	0	POWER IS ON

At the bottom, there is a 'DISPLAY' button, an 'INPUT' field, and an 'ERASE' button. A hand cursor is pointing to the upward arrow button on the right side.

6.10 TRACEABILITY setting

1. Press "TRACEABILITY" field on the screen.

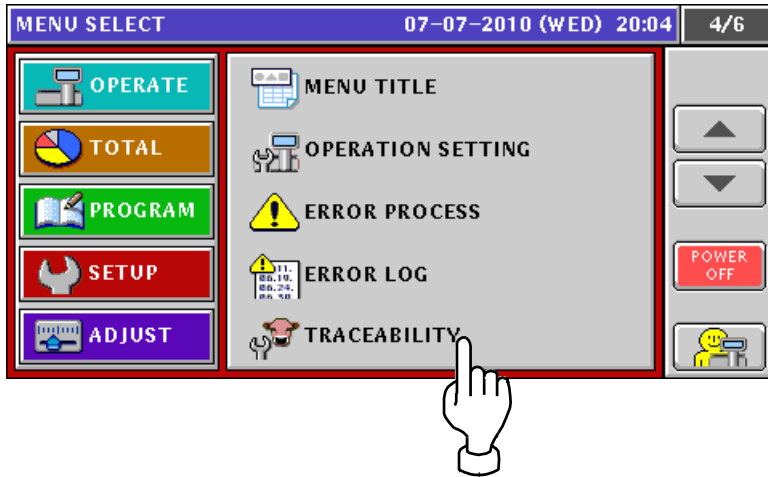

2. TRACEABILITY screen appears.
Then, press to select a desired field for each item.

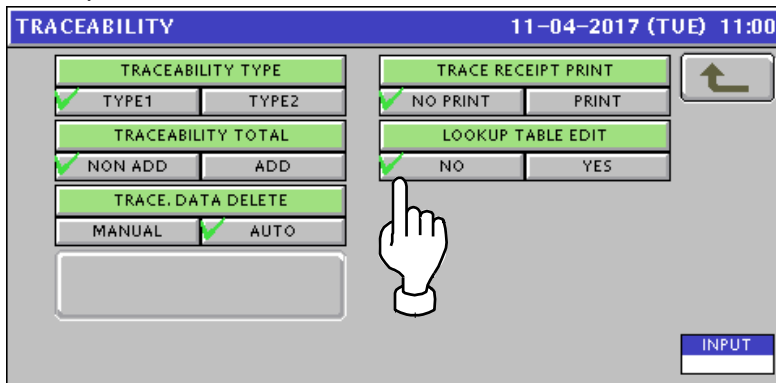

6.11 DUAL CURRENCY setting

1. Press "DUAL CURRENCY" field on the screen.



2. DUAL CURRENCY screen appears.
Then, enter a desired numeric value for each input item, and press to select a desired field for each selection item.

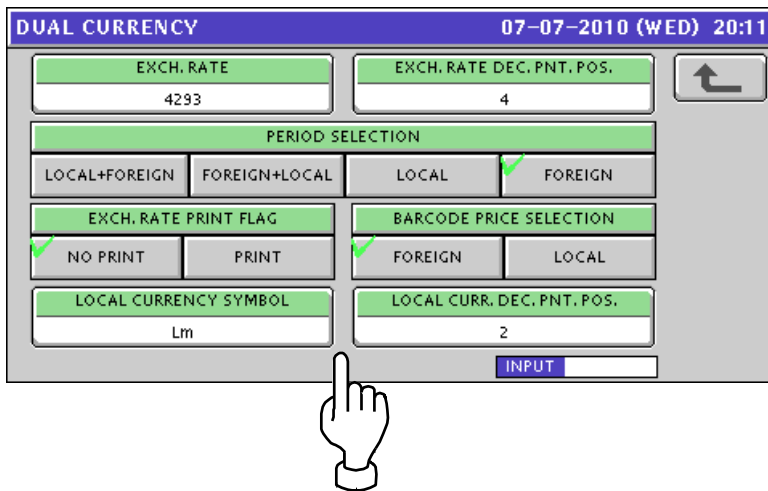

6.12 PRICE ROUNDING setting

1. Press "PRICE ROUNDING" field on the screen.



2. PRICE ROUNDING screen appears. Then, press to select a desired field for each item.

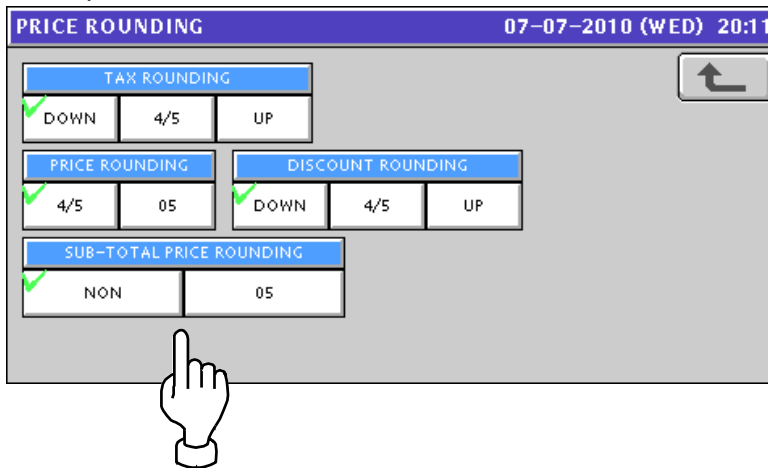

6.13 FREQUENT SHOPPER setting

1. Press "FREQUENT SHOPPER" field on the screen.

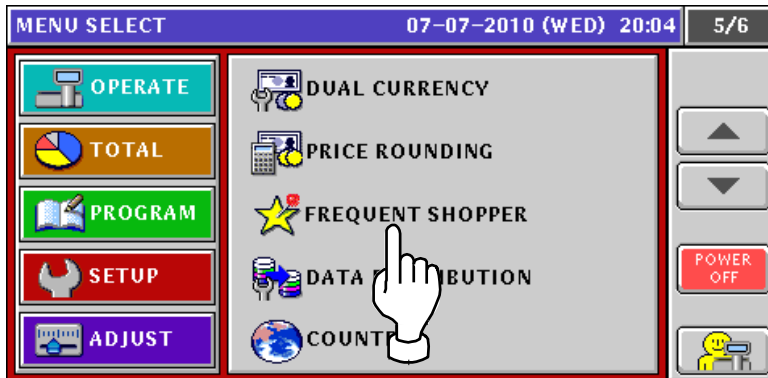

2. FREQUENT SHOPPER screen appears.
Then, press to select a desired field for each item.

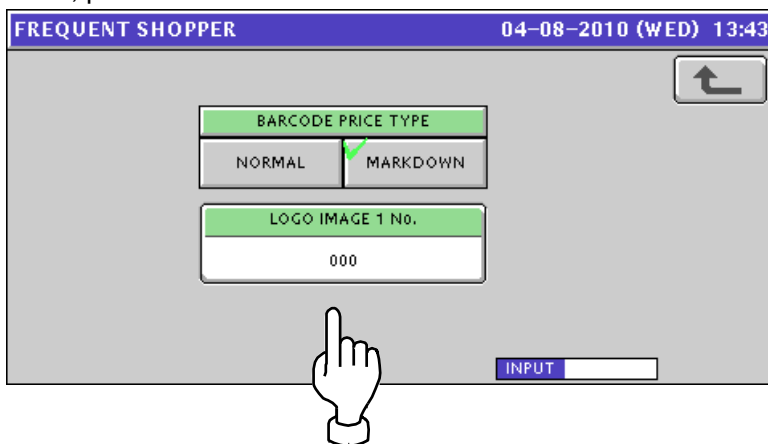

6.14 DATA DISTRIBUTION setting

1. Press "DATA DISTRIBUTION" field on the screen.

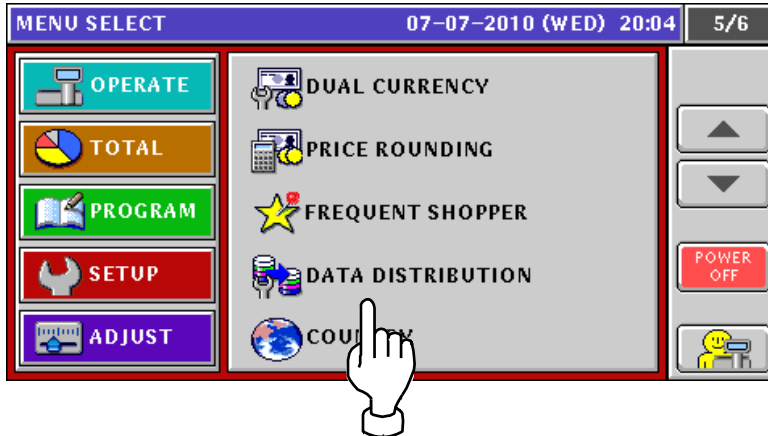

2. DATA DISTRIBUTION (MACHINE) screen appears.

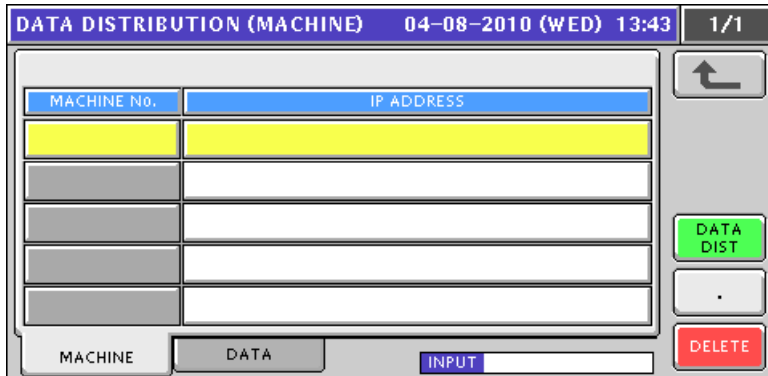

3. Press [DATA] tab on the screen.
Press [▼] or [▲] button when changing the pages.

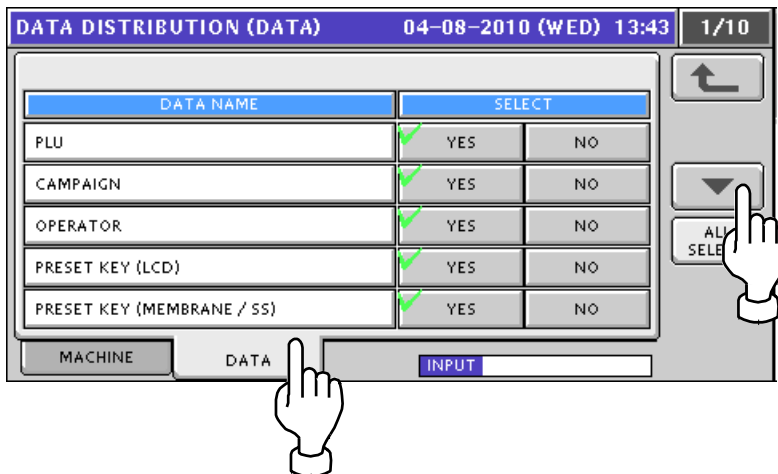

DATA DISTRIBUTION (DATA) 04-08-2010 (WED) 13:44 2/10

DATA NAME	SELECT	
AD MSG.	<input checked="" type="checkbox"/> YES	<input type="checkbox"/> NO
STORE	<input checked="" type="checkbox"/> YES	<input type="checkbox"/> NO
DEPARTMENT	<input checked="" type="checkbox"/> YES	<input type="checkbox"/> NO
GROUP	<input checked="" type="checkbox"/> YES	<input type="checkbox"/> NO
COOKING TIME	<input checked="" type="checkbox"/> YES	<input type="checkbox"/> NO

MACHINE DATA INPUT



DATA DISTRIBUTION (DATA) 04-08-2010 (WED) 13:44 3/10

DATA NAME	SELECT	
NUTRITION	<input checked="" type="checkbox"/> YES	<input type="checkbox"/> NO
EXTRA MSG. 1	<input checked="" type="checkbox"/> YES	<input type="checkbox"/> NO
EXTRA MSG. 2	<input checked="" type="checkbox"/> YES	<input type="checkbox"/> NO
EXTRA MSG. 3	<input checked="" type="checkbox"/> YES	<input type="checkbox"/> NO
COUPON MSG.	<input checked="" type="checkbox"/> YES	<input type="checkbox"/> NO

MACHINE DATA INPUT



DATA DISTRIBUTION (DATA) 04-08-2010 (WED) 13:44 4/10

DATA NAME	SELECT	
POP MSG.	<input checked="" type="checkbox"/> YES	<input type="checkbox"/> NO
SCHEME TABLE (BASIC)	<input checked="" type="checkbox"/> YES	<input type="checkbox"/> NO
GEN TABLE	<input checked="" type="checkbox"/> YES	<input type="checkbox"/> NO
LOOKUP TABLE	<input checked="" type="checkbox"/> YES	<input type="checkbox"/> NO
LOOKUP DATA	<input checked="" type="checkbox"/> YES	<input type="checkbox"/> NO

MACHINE DATA INPUT



DATA DISTRIBUTION (DATA) 04-08-2010 (WED) 13:44 5/10

DATA NAME	SELECT	
FIX PRICE SYMBOL	<input checked="" type="checkbox"/> YES	<input type="checkbox"/> NO
FREE MSG. 1	<input checked="" type="checkbox"/> YES	<input type="checkbox"/> NO
FREE MSG. 2	<input checked="" type="checkbox"/> YES	<input type="checkbox"/> NO
FREE MSG. 3	<input checked="" type="checkbox"/> YES	<input type="checkbox"/> NO
FREE MSG. 4	<input checked="" type="checkbox"/> YES	<input type="checkbox"/> NO

MACHINE DATA INPUT



DATA DISTRIBUTION (DATA) 04-08-2010 (WED) 13:44 6/10

DATA NAME	SELECT	
FREE MSG. 5	<input checked="" type="checkbox"/> YES	<input type="checkbox"/> NO
FREE MSG. 6	<input checked="" type="checkbox"/> YES	<input type="checkbox"/> NO
FREE MSG. 7	<input checked="" type="checkbox"/> YES	<input type="checkbox"/> NO
FREE MSG. 8	<input checked="" type="checkbox"/> YES	<input type="checkbox"/> NO
FREE MSG. 9	<input checked="" type="checkbox"/> YES	<input type="checkbox"/> NO

MACHINE DATA INPUT



DATA DISTRIBUTION (DATA) 04-08-2010 (WED) 13:44 7/10

DATA NAME	SELECT	
FREE MSG. 10	<input checked="" type="checkbox"/> YES	<input type="checkbox"/> NO
FREE MSG. 11	<input checked="" type="checkbox"/> YES	<input type="checkbox"/> NO
FREE MSG. 12	<input checked="" type="checkbox"/> YES	<input type="checkbox"/> NO
FREE MSG. 13	<input checked="" type="checkbox"/> YES	<input type="checkbox"/> NO
FREE MSG. 14	<input checked="" type="checkbox"/> YES	<input type="checkbox"/> NO

MACHINE DATA INPUT



DATA DISTRIBUTION (DATA) 04-08-2010 (WED) 13:44 8/10

DATA NAME	SELECT	
FREE MSG. 15	<input checked="" type="checkbox"/> YES	<input type="checkbox"/> NO
LOGO IMAGE	<input checked="" type="checkbox"/> YES	<input type="checkbox"/> NO
DISP IMAGE	<input checked="" type="checkbox"/> YES	<input type="checkbox"/> NO
PASSWORD	<input checked="" type="checkbox"/> YES	<input type="checkbox"/> NO
CASSETTE	<input checked="" type="checkbox"/> YES	<input type="checkbox"/> NO

MACHINE DATA INPUT



DATA DISTRIBUTION (DATA) 04-08-2010 (WED) 13:44 9/10

DATA NAME	SELECT	
LABEL	<input checked="" type="checkbox"/> YES	<input type="checkbox"/> NO
FORMAT	<input checked="" type="checkbox"/> YES	<input type="checkbox"/> NO
FREE MASTER NAME	<input checked="" type="checkbox"/> YES	<input type="checkbox"/> NO
SYSTEM	<input checked="" type="checkbox"/> YES	<input type="checkbox"/> NO
STAMP PRICE	<input checked="" type="checkbox"/> YES	<input type="checkbox"/> NO

MACHINE DATA INPUT



DATA DISTRIBUTION (DATA)		04-08-2010 (WED) 13:44		10/10	
DATA NAME	SELECT				
G_NUTRITION	<input checked="" type="checkbox"/>	YES	NO		
	<input type="checkbox"/>	YES	NO		
	<input type="checkbox"/>	YES	NO		
	<input type="checkbox"/>	YES	NO		
	<input type="checkbox"/>	YES	NO		

MACHINE DATA INPUT

Navigation buttons: Up arrow, Down arrow, ALL SELECT

6.15 COUNTRY setting

1. Press "COUNTRY" field on the screen.

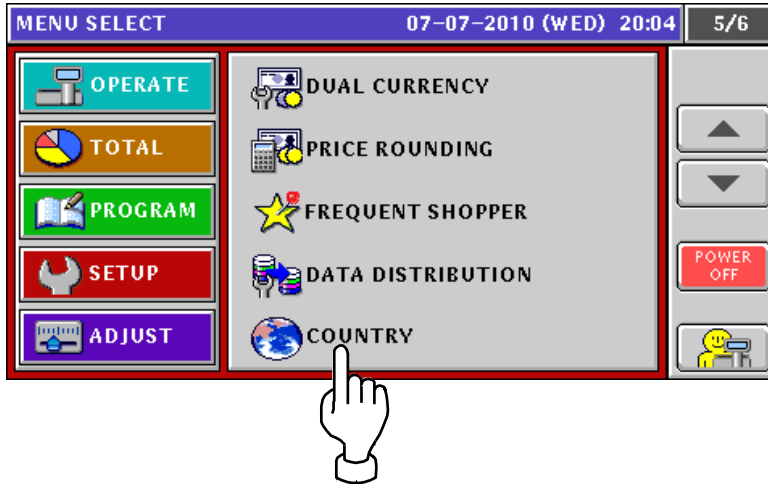

2. COUNTRY screen appears.

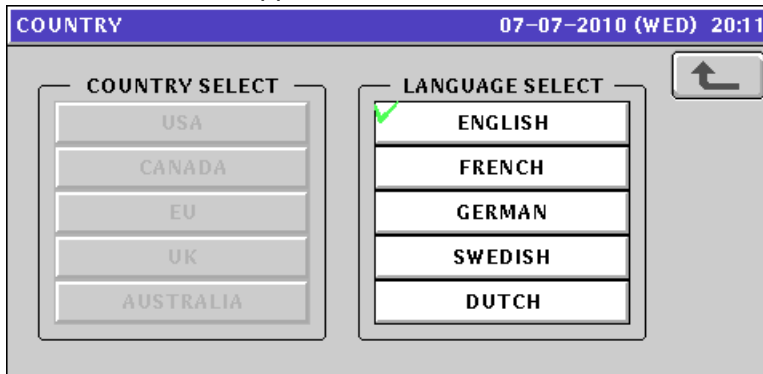

Then, press to select a desired country and language.

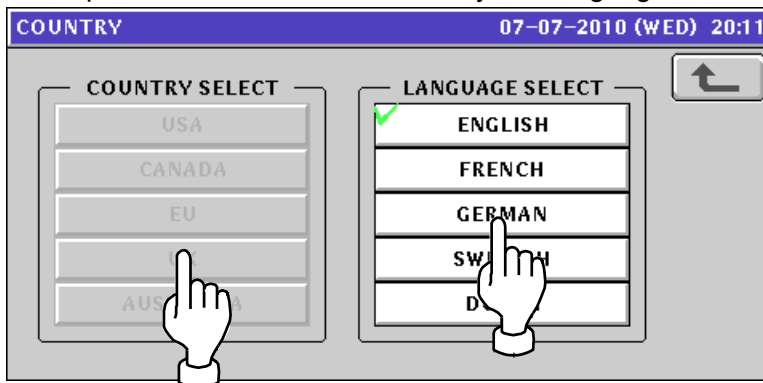

6.16 FILE SAVE / LOAD

Before saving or loading the main memory data to or from the USB memory, make sure that the USB memory is inserted into the USB port located in the connector cover of the main body.

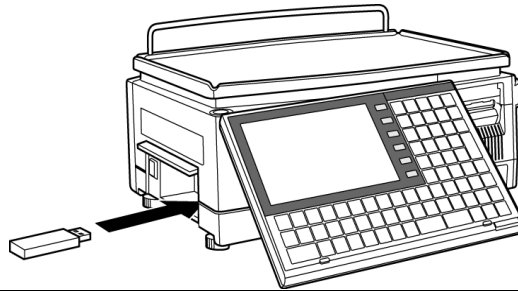

1. Press "FILE SAVE / LOAD." field on the screen.

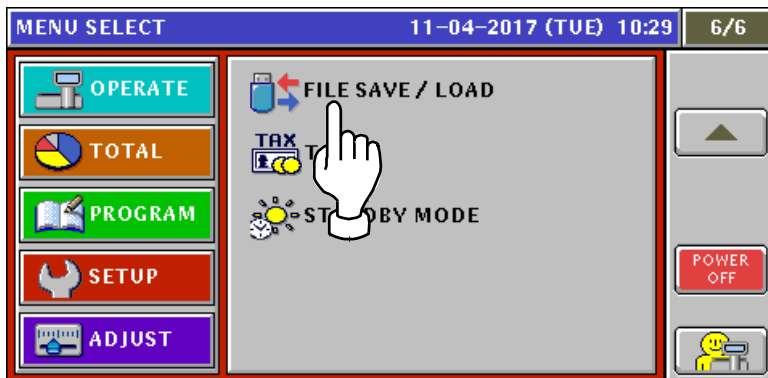

2. FILE SAVE/LOAD (USB > SCALE) screen appears for loading the USB memory data to the main memory. To display FILE INOUT (DETAIL) screen, press [DETAIL] button.

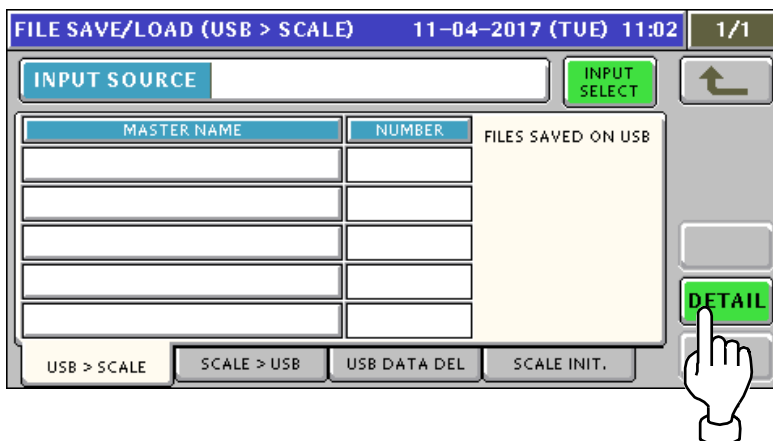

Press to select a desired field for each item.

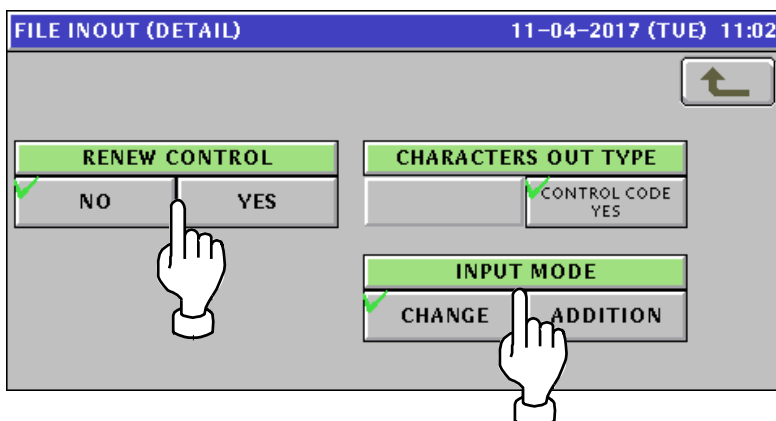

3. Press “SCALE > USB” tab to display FILE SAVE/LOAD (SCALE > USB) screen for loading the main memory data to the USB memory.

Be sure to press to select a desired data type in “DATA” field.

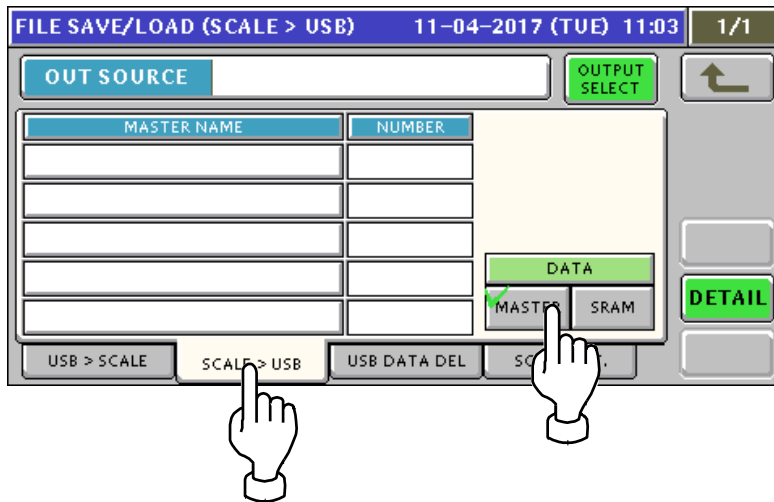

Press to select a desired field for each item.

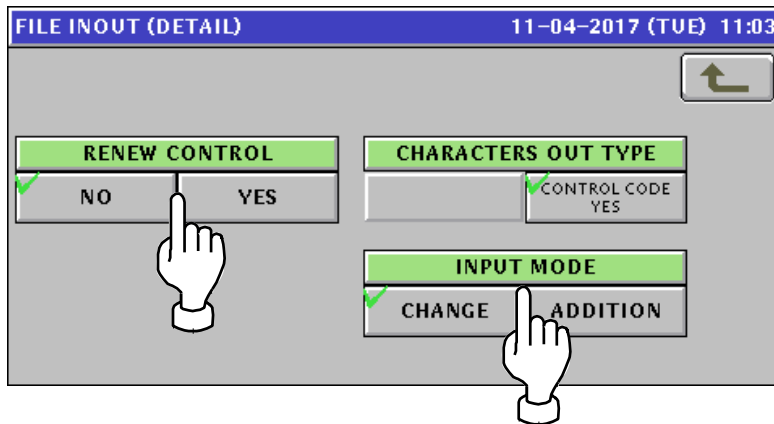

4. Press “USB DATA DEL” tab to display FILE SAVE/LOAD (USB DATA DEL) screen.

Be sure to press to select a desired data type in “DATA” field.

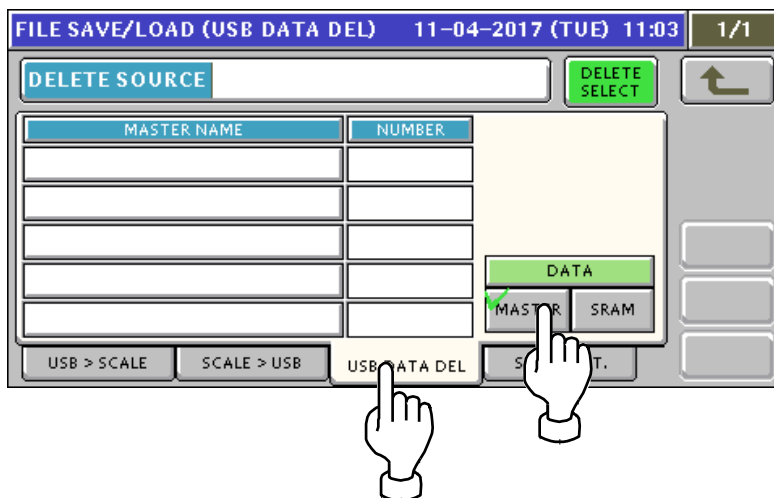

5. Press "SCALE INIT." tab to display FILE SAVE/LOAD (SCALE INIT) screen.
Press [▼] or [▲] button when changing the pages.

FILE SAVE/LOAD (SCALE INIT) 28-07-2010 (WED) 13:35 1/11

DATA INTERNAL MASTER

MASTER NAME	NUMBER	MEMORY SPACE
PLU	30(30)	1,771 KB
STORE	2	PLU MASTER CONV.
FIX PRICE SYMBOL	16	2525 EA
FREE MSG. 1	0	
FREE MSG. 2	0	

USB > SCALE SCALE > USB USB DATA DEL SCALE INIT. EXECUTE

FILE SAVE/LOAD (SCALE INIT) 28-07-2010 (WED) 13:36 2/11

DATA INTERNAL MASTER

MASTER NAME	NUMBER	MEMORY SPACE
FREE MSG. 3	0	1,771 KB
FREE MSG. 4	0	PLU MASTER CONV.
FREE MSG. 5	0	2525 EA
FREE MSG. 6	0	
FREE MSG. 7	0	

USB > SCALE SCALE > USB USB DATA DEL SCALE INIT. EXECUTE

FILE SAVE/LOAD (SCALE INIT) 28-07-2010 (WED) 13:36 3/11

DATA INTERNAL MASTER

MASTER NAME	NUMBER	MEMORY SPACE
FREE MSG. 8	0	1,771 KB
FREE MSG. 9	0	PLU MASTER CONV.
FREE MSG. 10	0	2525 EA
FREE MSG. 11	0	
FREE MSG. 12	0	

USB > SCALE SCALE > USB USB DATA DEL SCALE INIT. EXECUTE

FILE SAVE/LOAD (SCALE INIT) 28-07-2010 (WED) 13:36 4/11

DATA INTERNAL MASTER

MASTER NAME	NUMBER	MEMORY SPACE
FREE MSG. 13	0	1,771 KB
FREE MSG. 14	0	PLU MASTER CONV.
FREE MSG. 15	0	2525 EA
EXTRA MSG. 1	0	
EXTRA MSG. 2	0	

USB > SCALE SCALE > USB USB DATA DEL SCALE INIT. EXECUTE

FILE SAVE/LOAD (SCALE INIT) 28-07-2010 (WED) 13:36 5/11

DATA INTERNAL MASTER

MASTER NAME	NUMBER	MEMORY SPACE
EXTRA MSG.3	0	1,771 KB
COUPON MSG.	0	PLU MASTER CONV.
POP MSG.	6	2525 EA
PRESET KEY (LCD)	240	
FORMAT	0	

USB > SCALE SCALE > USB USB DATA DEL SCALE INIT. EXECUTE

FILE SAVE/LOAD (SCALE INIT) 28-07-2010 (WED) 13:36 6/11

DATA INTERNAL MASTER

MASTER NAME	NUMBER	MEMORY SPACE
LABEL	8	1,771 KB
CASSETTE	8	PLU MASTER CONV.
SYSTEM	1	2525 EA
PLU INITIAL DATA	1	
LOGO IMAGE	31	

USB > SCALE SCALE > USB USB DATA DEL SCALE INIT. EXECUTE

FILE SAVE/LOAD (SCALE INIT) 28-07-2010 (WED) 13:36 7/11

DATA INTERNAL MASTER

MASTER NAME	NUMBER	MEMORY SPACE
NUTRITION	0	1,771 KB
COOKING TIME	0	PLU MASTER CONV.
MENU TITLE	256	2525 EA
AD MSG.	0	
SCHEME TABLE (BASIC)	0	

USB > SCALE SCALE > USB USB DATA DEL SCALE INIT. EXECUTE

FILE SAVE/LOAD (SCALE INIT) 28-07-2010 (WED) 13:36 8/11

DATA INTERNAL MASTER

MASTER NAME	NUMBER	MEMORY SPACE
SCHEME TABLE (ID)	0	1,771 KB
SCHEME TABLE (RECORD)	0	PLU MASTER CONV.
GEN TABLE	9	2525 EA
LOOKUP TABLE	0	
LOOKUP DATA	0	

USB > SCALE SCALE > USB USB DATA DEL SCALE INIT. EXECUTE

FILE SAVE/LOAD (SCALE INIT) 28-07-2010 (WED) 13:36 9/11

DATA INTERNAL MASTER

MASTER NAME	NUMBER	MEMORY SPACE
TRACE DATA (BASIC)	0	1,771 KB
TRACE DATA (AI)	0	PLU MASTER CONV.
CAMPAIGN	0	2525 EA
CAMPAIGN DATA	0	
DEPARTMENT	0	

USB > SCALE SCALE > USB USB DATA DEL SCALE INIT. EXECUTE

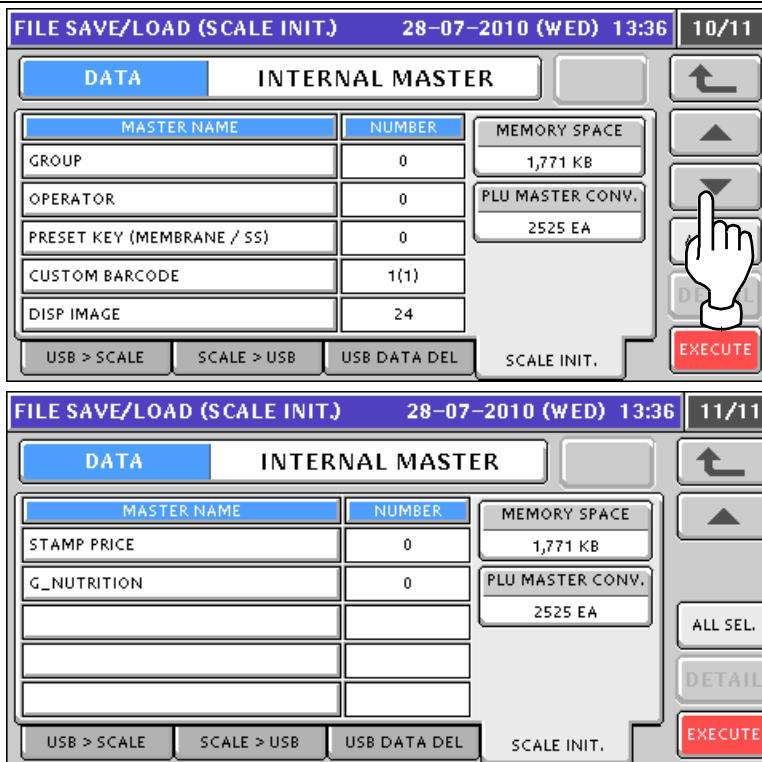

6. Press to select desired files for initialization, and press [EXECUTE] button.

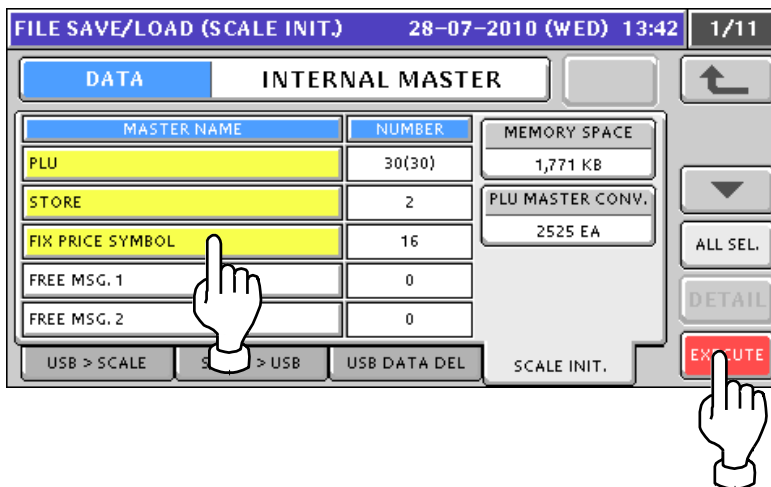

7. The following confirmation screen appears.
Then, press [EXEC] button to execute file initialization.

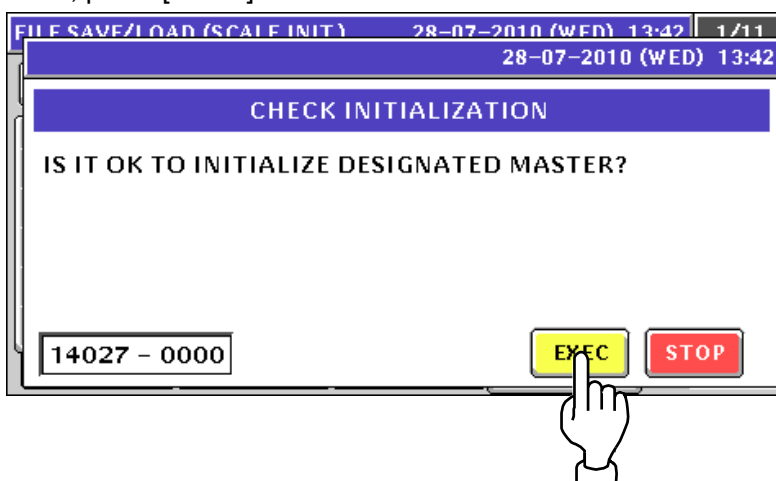

Chapter 7 ADJUSTment mode

7.1 ADJUSTment mode entry

1. Press [Mode] button to enter MENU SELECT screen.

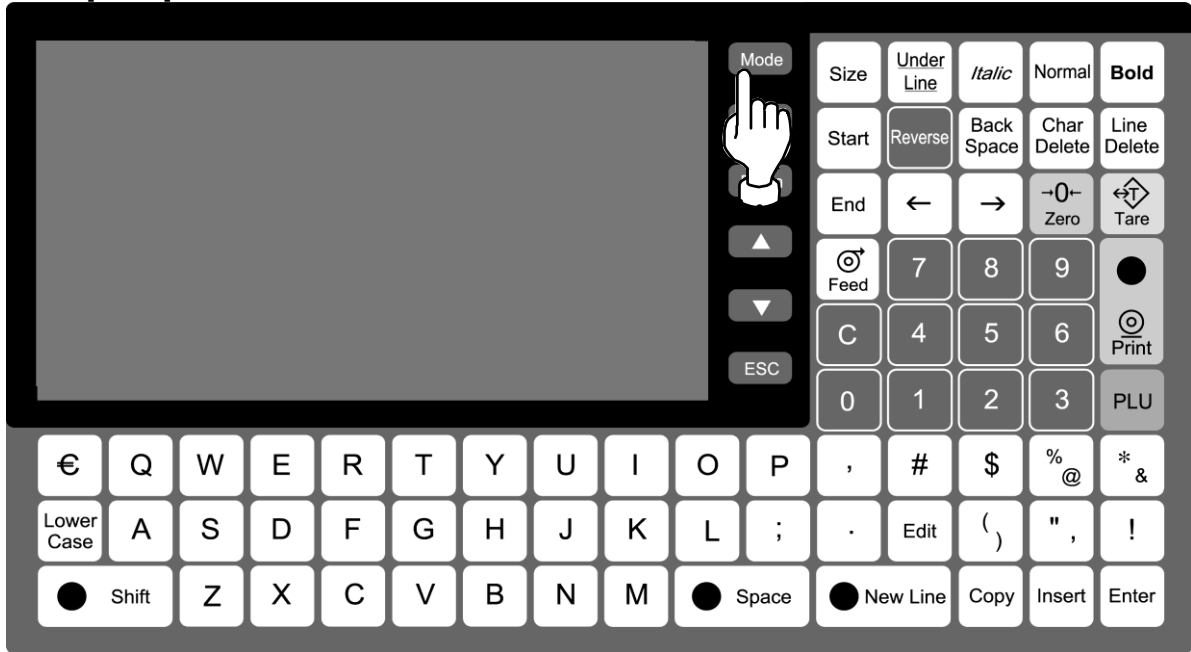

2. Press [ADJUST] button on MENU SELECT screen.

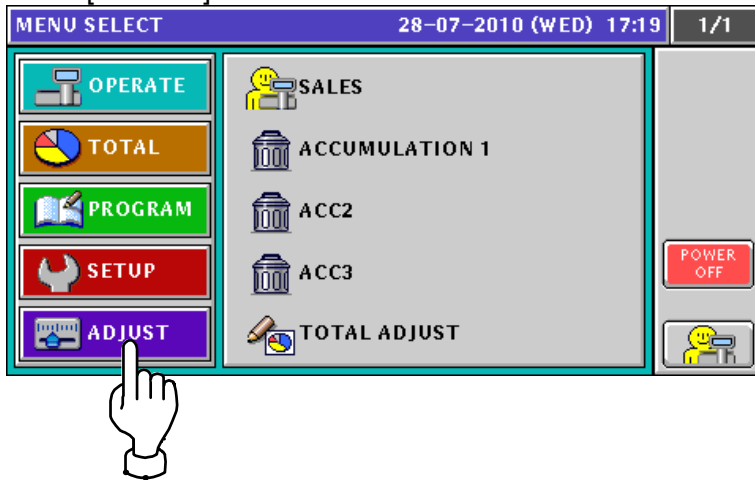

3. The Adjustment Menu screen appears.

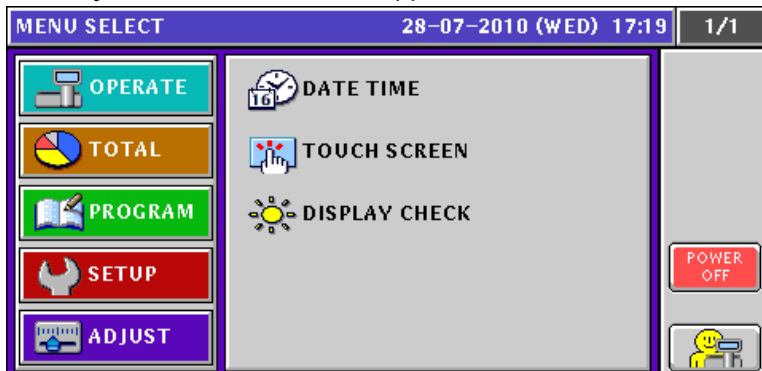

4. Enter "495344" and press [PLU] key on the key sheet to enter Service Mode.



Hidden menus come up on the screen.

Press [▼] or [▲] button when changing the pages.

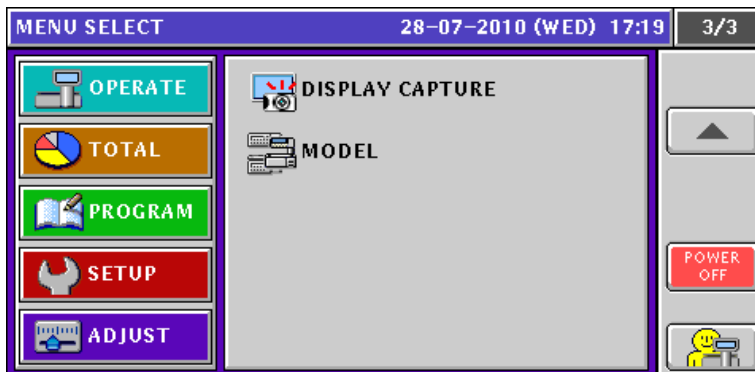
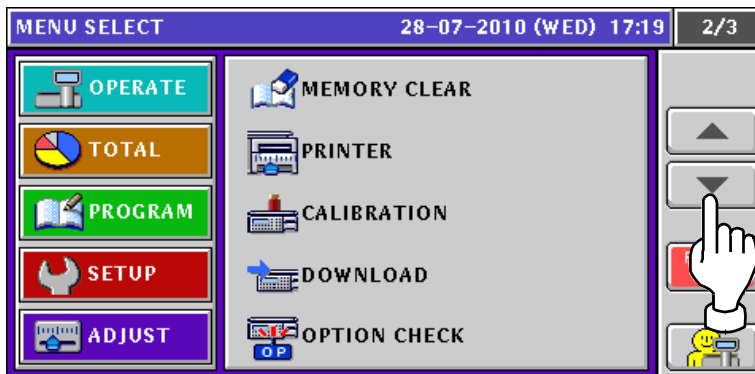
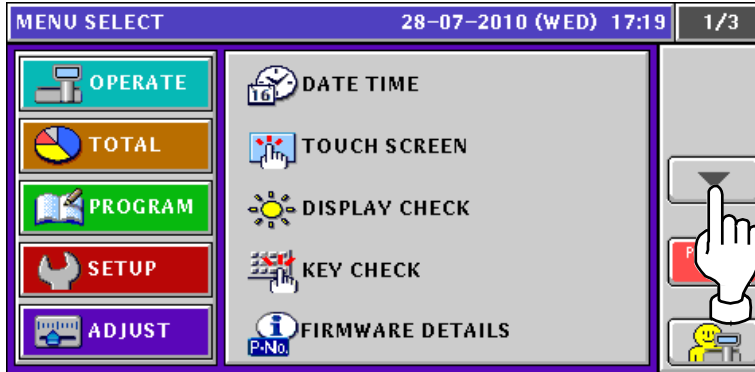

7.2 KEY CHECK

1. Press "KEY CHECK" field on the screen.

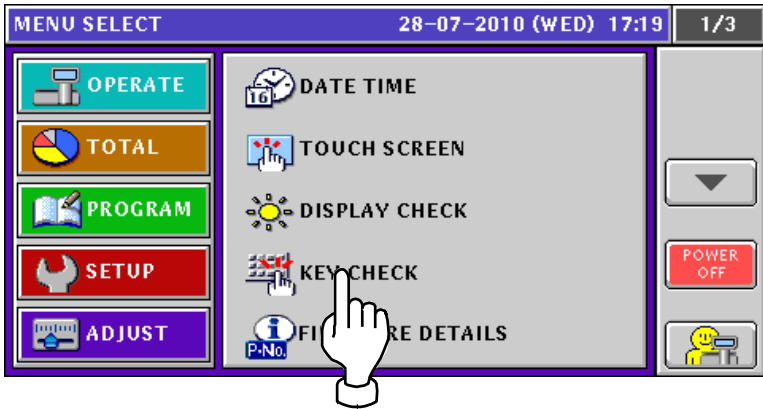

2. KEY CHECK (KEY) screen appears.

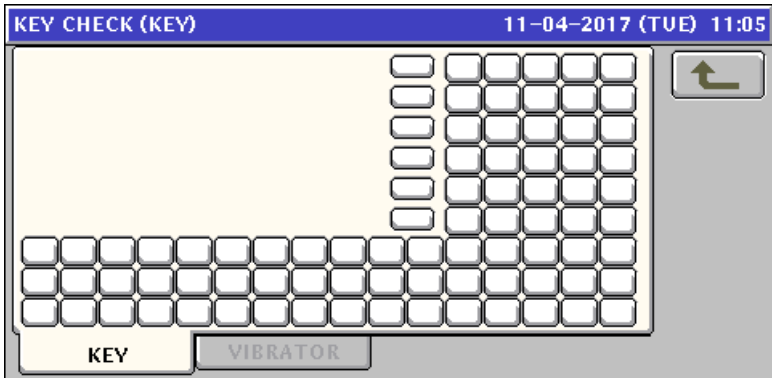

Press any keys on the membrane key sheet and confirm that the corresponding key colors on the screen change into green.

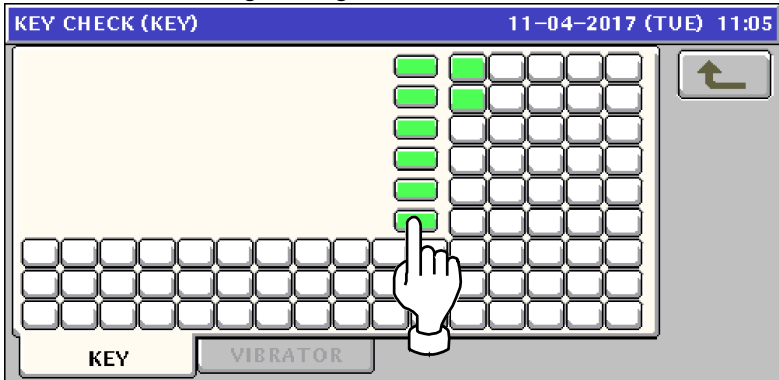

7.3 FIRMWARE DETAILS

1. Press "FIRMWARE DETAILS" field on the screen.

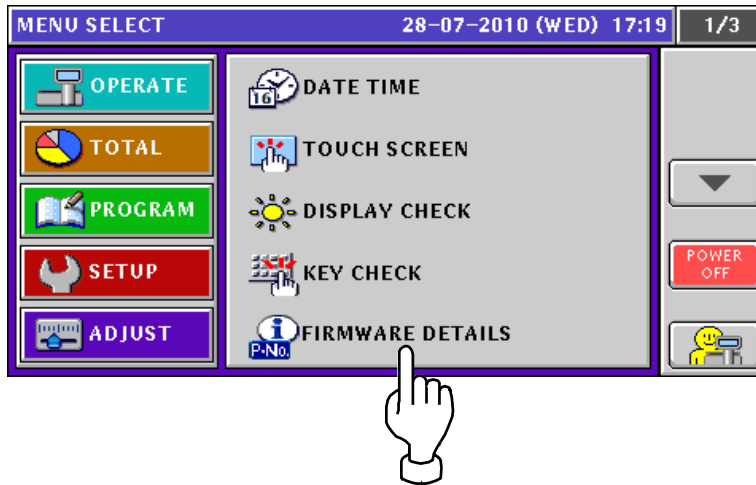

2. FIRMWARE DETAILS screen appears.
Then, confirm the program numbers used in this machine.

The screenshot shows the 'FIRMWARE DETAILS' screen with a purple header bar containing the date and time '11-04-2017 (TUE) 11:07'. Below the header is a table with two columns: 'SOFTWARE' and 'VERSION No.'. The table contains the following data:

SOFTWARE	VERSION No.
TITLE SOFTWARE	B0664P
MAIN	B0665M
OS	VxWorks5.5.1- B0667D
BOOT ROM	PK270143
KEY BOARD	B0614
SCALE	J0659
PRINTER1 (FPGA)	J0758AJ3

On the right side of the table, there is a green arrow button pointing up and to the left.

7.4 MEMORY CLEAR

1. Press "MEMORY CLEAR" field on the screen.

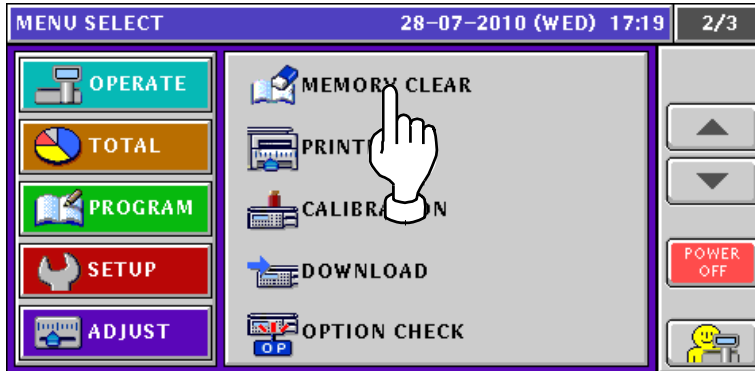

2. MEMORY CLEAR screen appears.

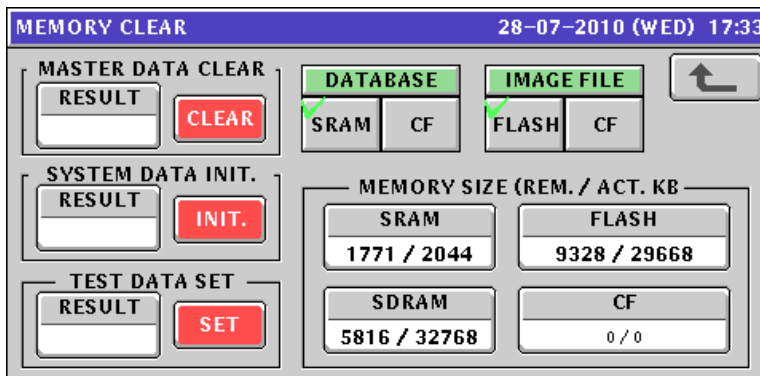

3. To clear the master data, press [CLEAR] button.

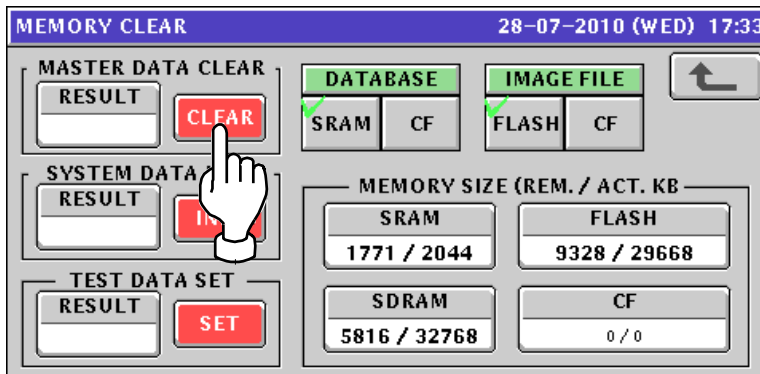

4. To initialize the system data, press [INIT.] button.

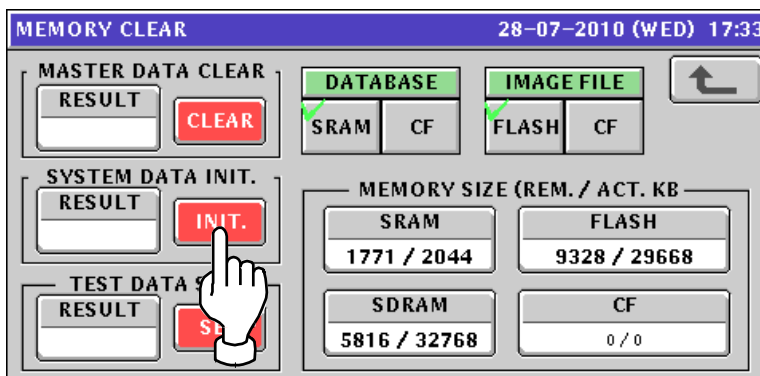

5. To set the test data, press [SET] button.

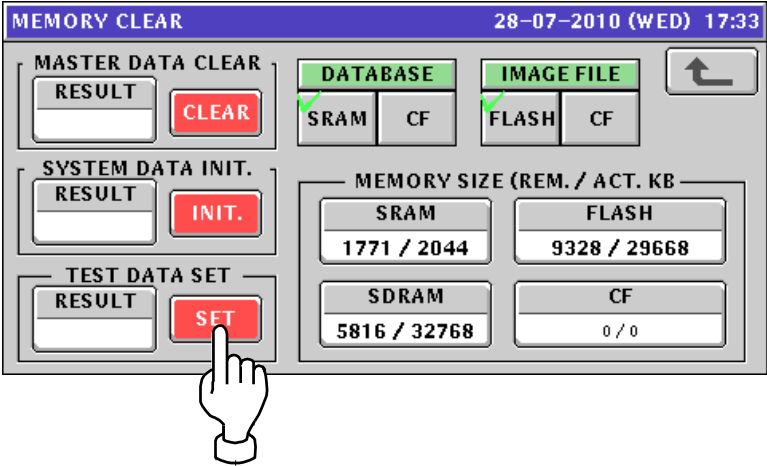

6. The following confirmation screen appears. Then, press [EXEC] button for execution.

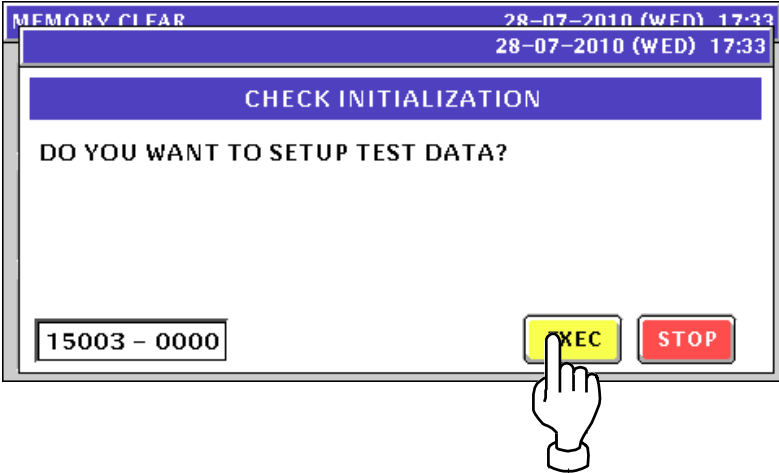

7.5 PRINTER adjustment

1. Press "PRINTER" field on the screen.

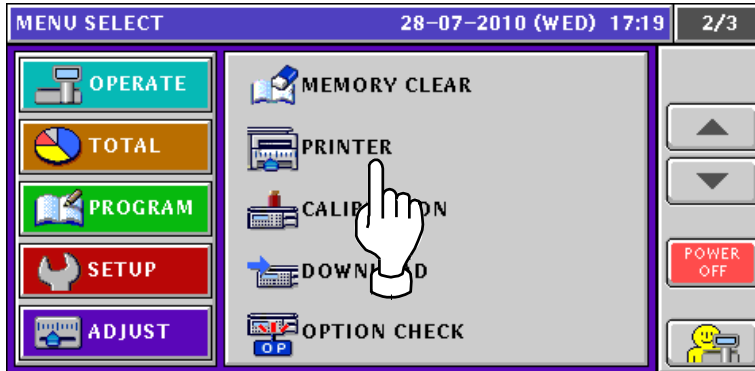

2. PRINTER (HEAD) screen appears. Then, select a desired printer by using either [<] or [>] button.

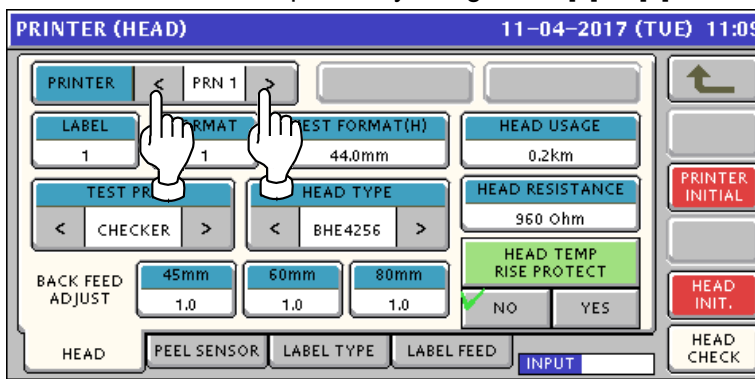

Enter a desired numeric value for each item and press the corresponding field.

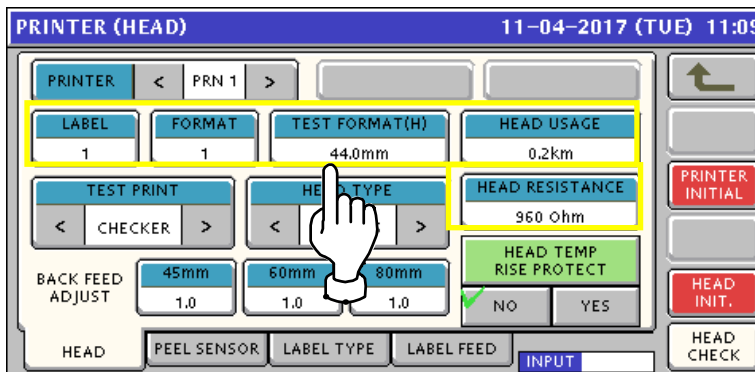

Select a desired test print type and head type by using either [<] or [>] button.

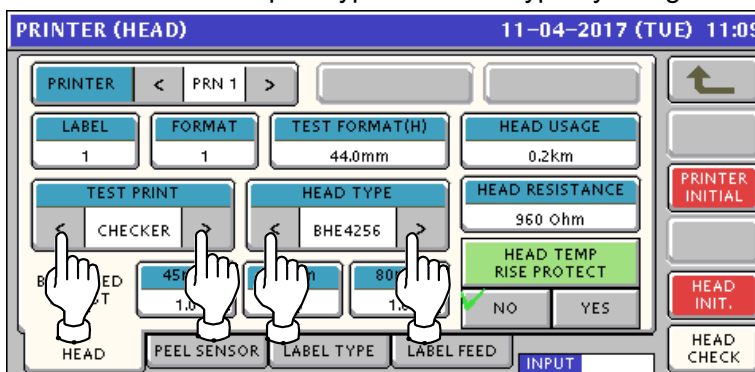

Perform back feed adjustment by entering a desired numeric value for each item and pressing the corresponding field.

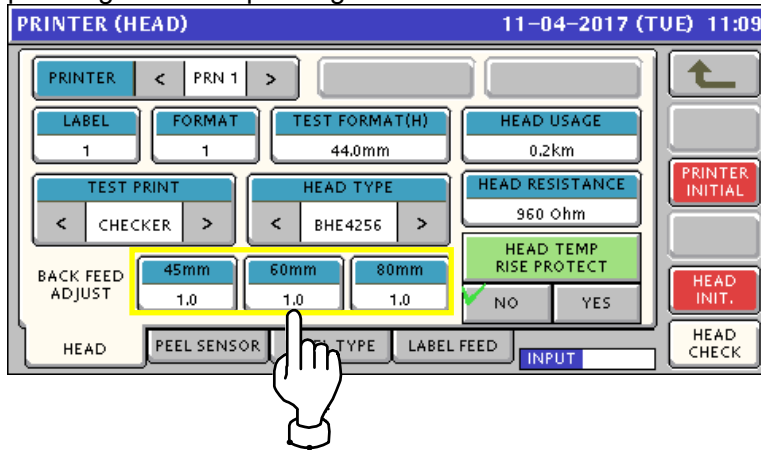

Press a desired field to select whether or not to use the head temperature rise protect function.

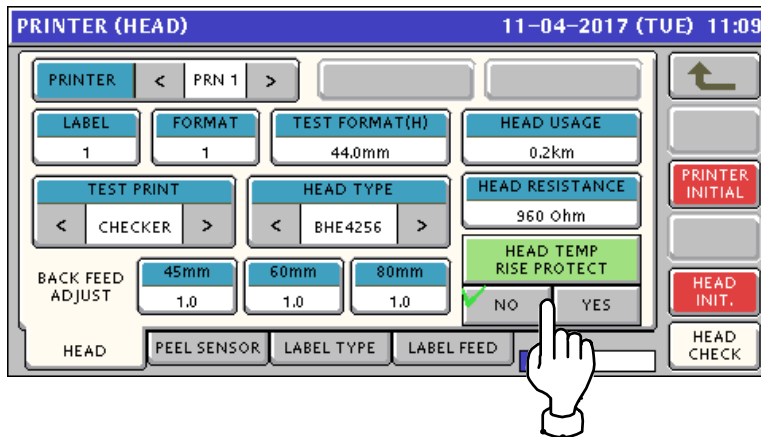

3. When initializing the printer, press [PRINTER INITIAL] button.

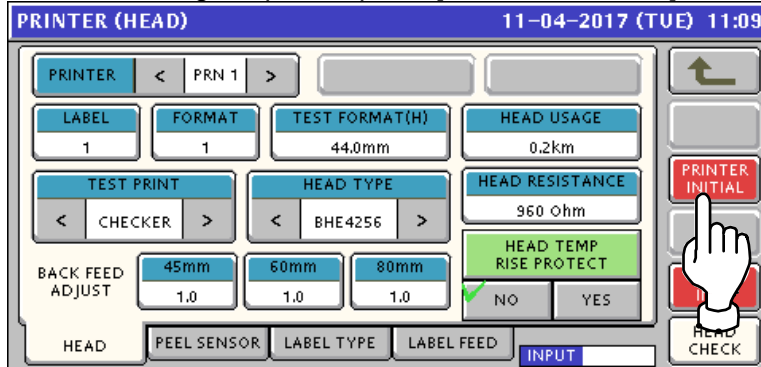

Press [EXEC] button for execution.

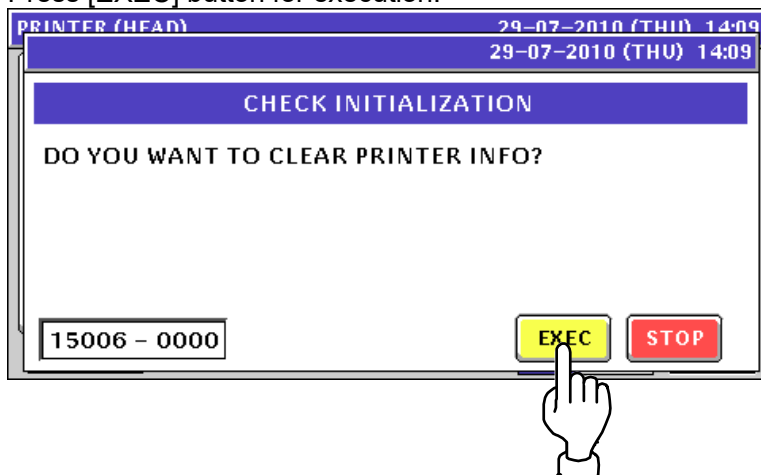

4. When initializing the thermal head, press [HEAD INIT.] button.

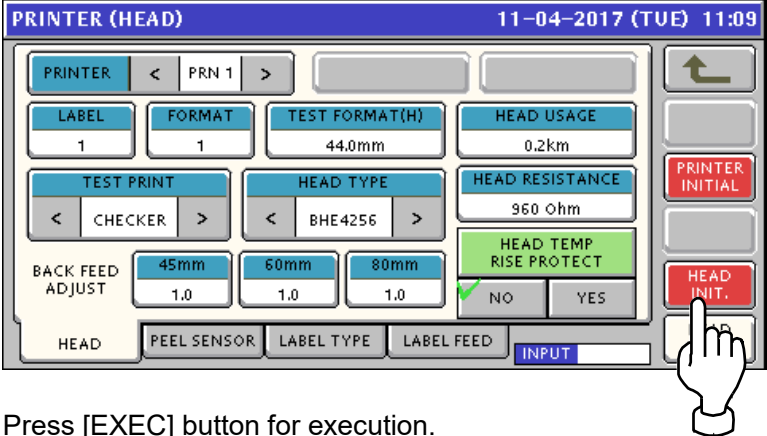

Press [EXEC] button for execution.

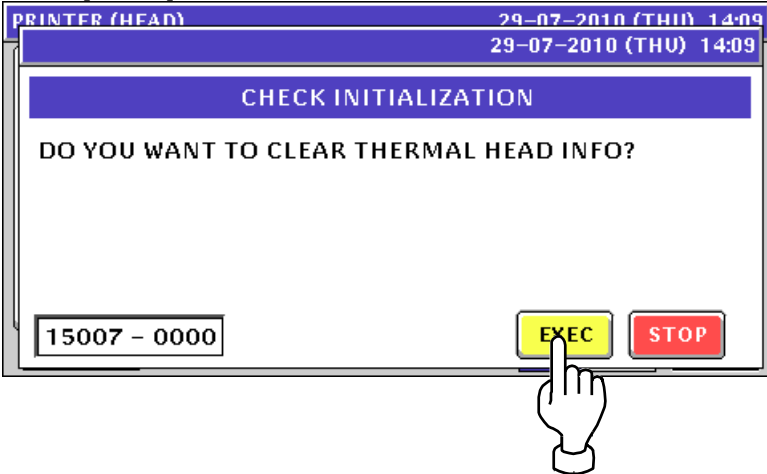

Press [HEAD CHECK] button to check whether the thermal head functions properly or not. You can hear the beep sound when the head is functioning properly.

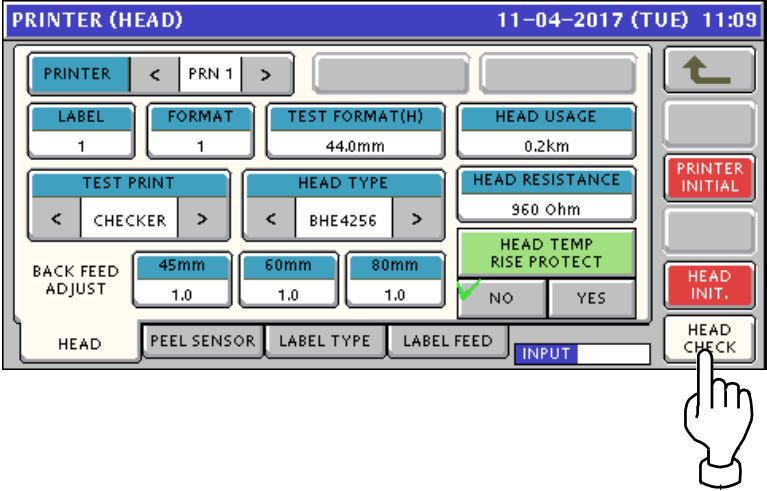

5. Press [PEEL SENSOR] tab to display PRINTER (PEEL SENSOR) screen.

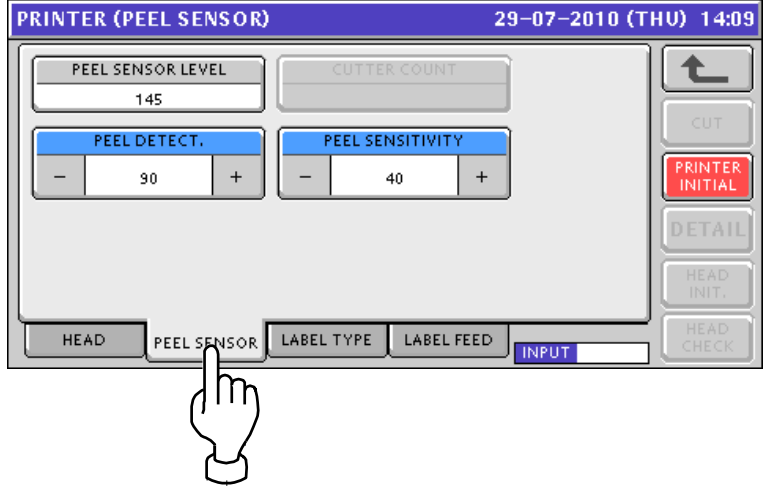

When initializing the printer, press [PRINTER INITIAL] button.

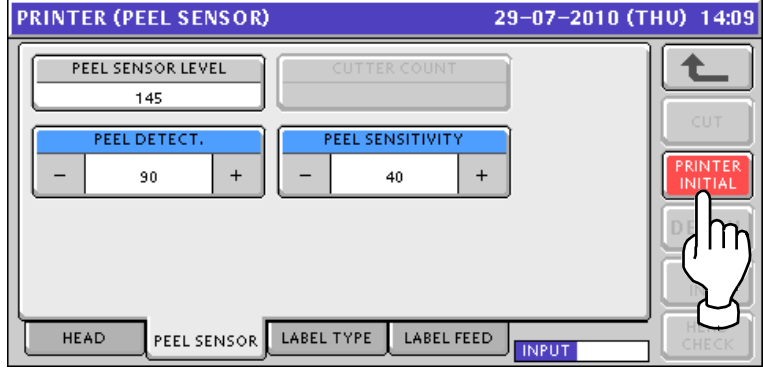

Press [EXEC] button for execution.

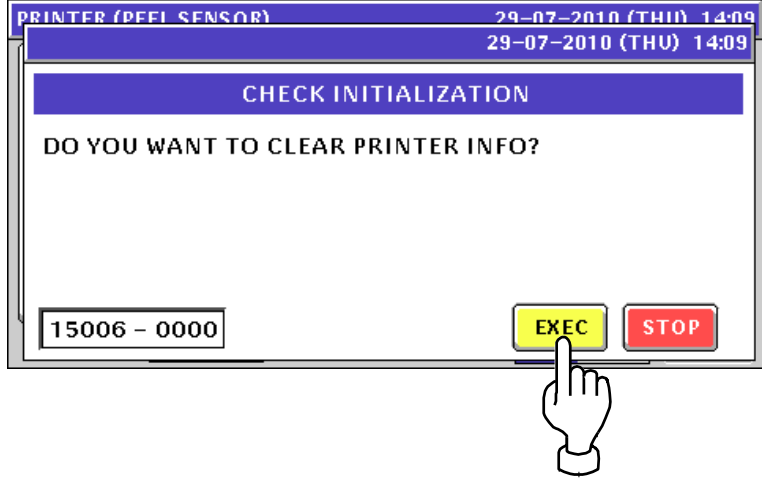

6. Press [LABEL TYPE] tab to display PRINTER (LABEL TYPE) screen.

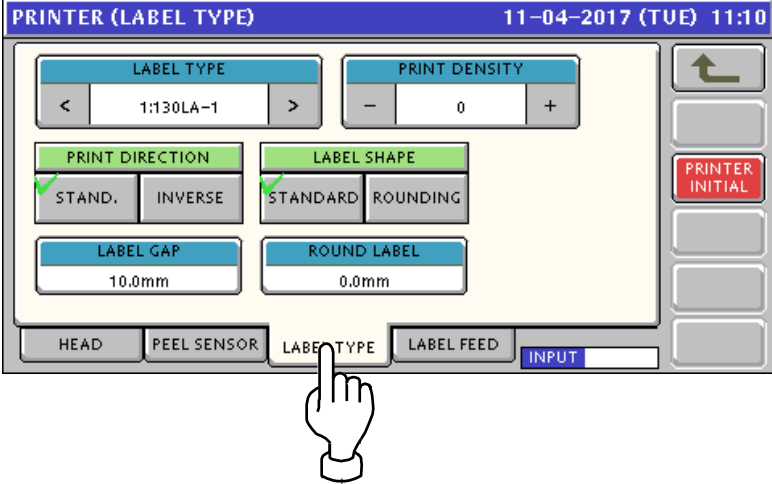

Select a desired label type by using either [<] or [>] button.

- 0: Receipt
- 1: 130LA-1
- 3: 150LA-1

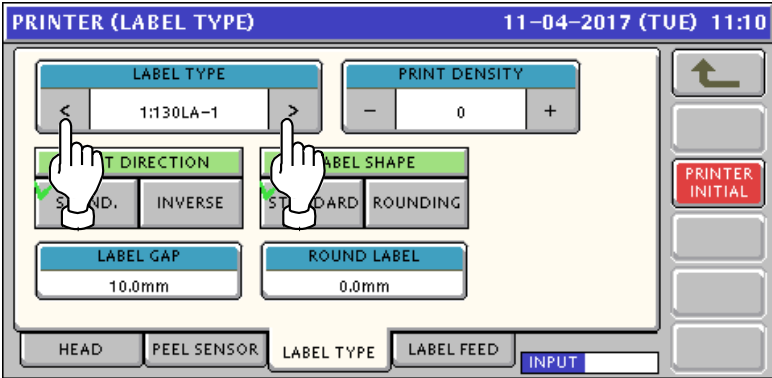

Select a desired print density level by using either [<] or [>] button, or, pressing the corresponding field after numeric data entry.

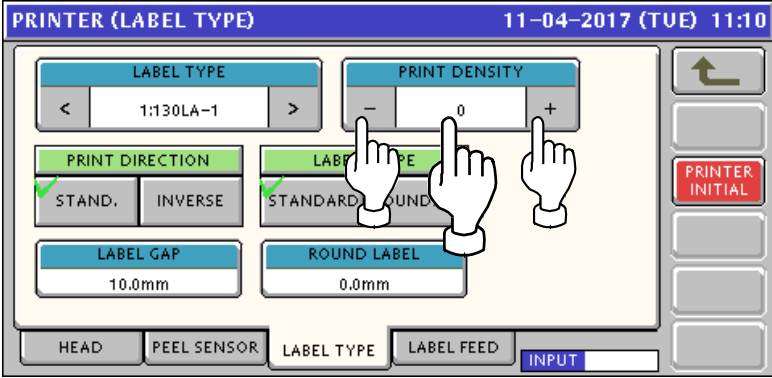

Press to select a desired field for each item.

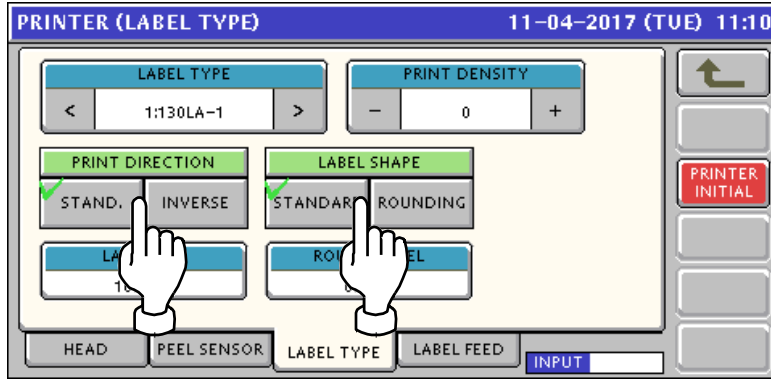

Enter a desired numeric value for each item and press the corresponding field.

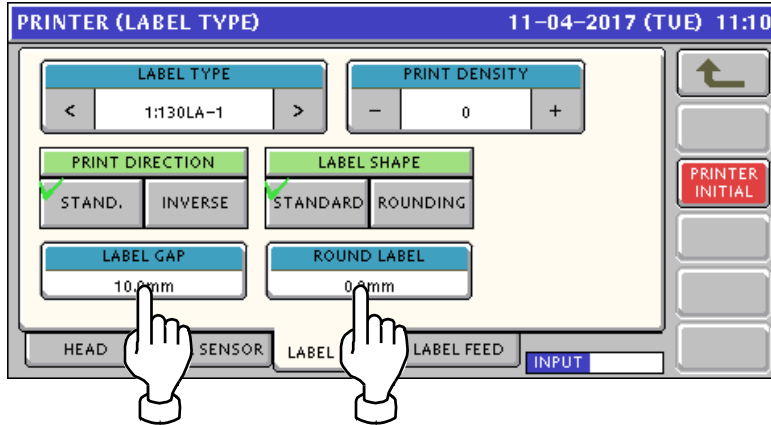

When initializing the printer, press [PRINTER INITIAL] button.

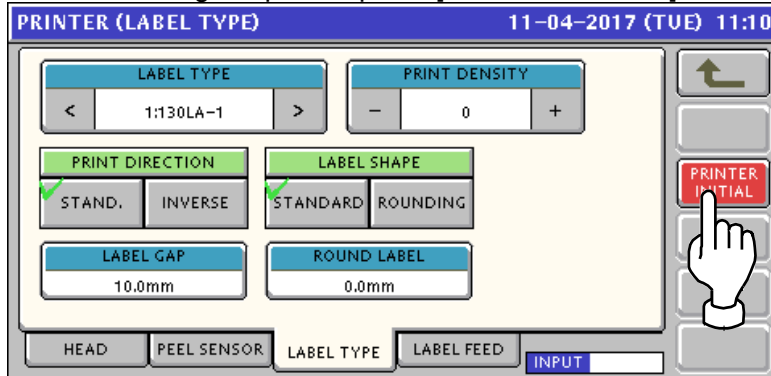

Press [EXEC] button for execution.

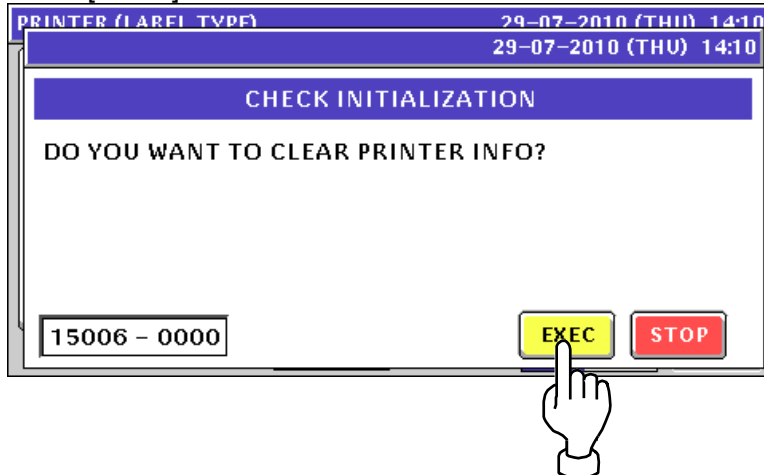

7. Press [LABEL FEED] tab to display PRINTER (LABEL FEED) screen.

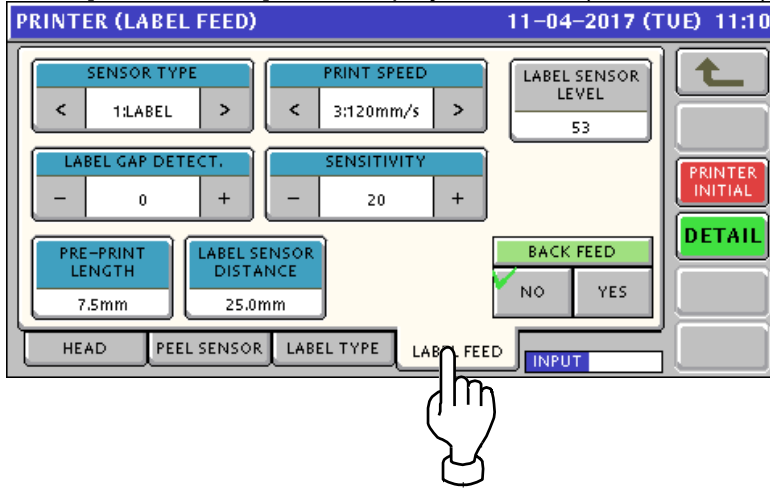

Select a desired sensor type and print speed by using either [<] or [>] button.

<Sensor Type>

0: None

1: Label

<Print Speed>

1: 80mm/sec

2: 100mm/sec

3: 120mm/sec

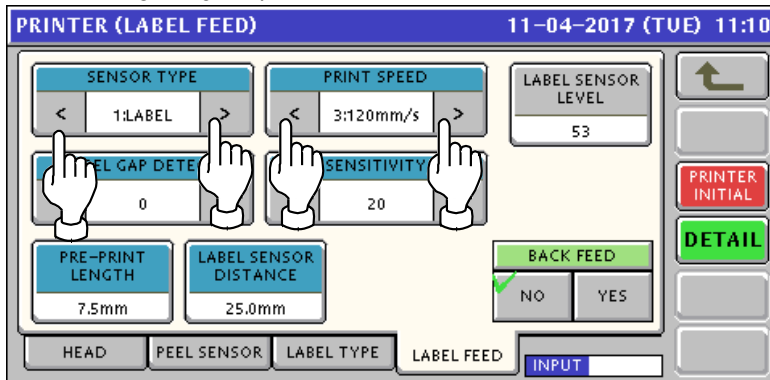

Select a desired numeric value for sensor scope and sensitivity levels by using either [-] or [+] button, or, pressing the corresponding field after numeric data entry.

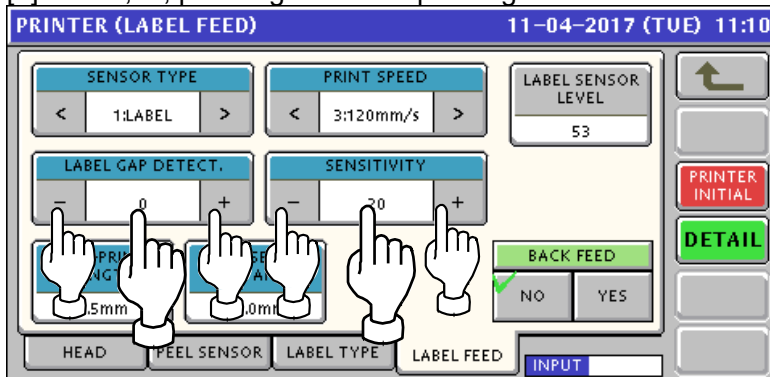

Enter a desired numeric value for each item and press the corresponding field.

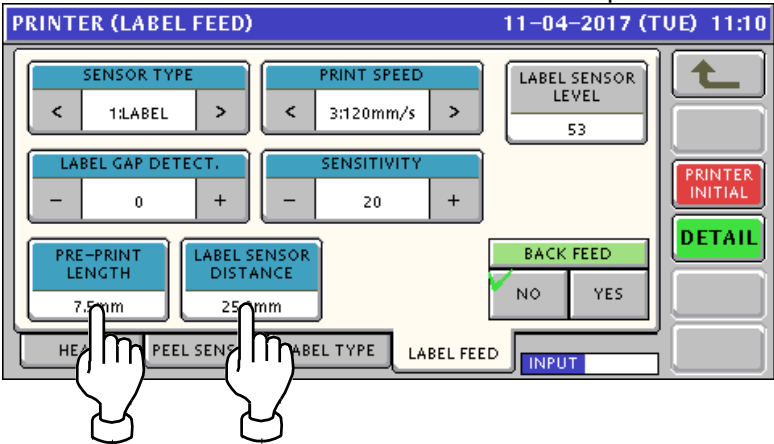

Press a desired field to select whether or not to use the back feed function.

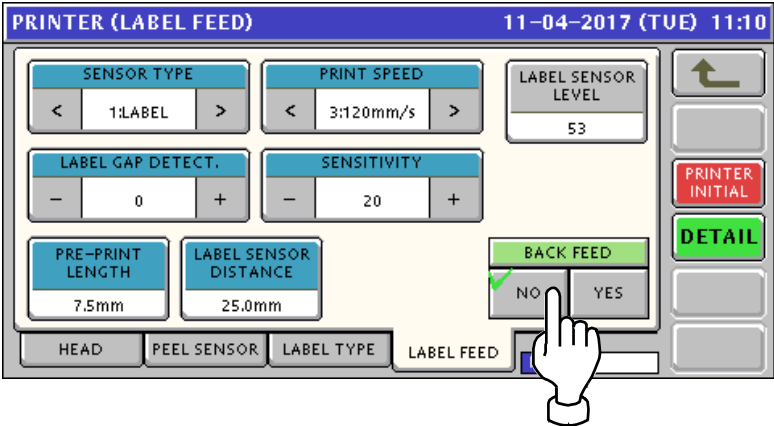

To display the detailed data of the printer, press [DETAIL] button.

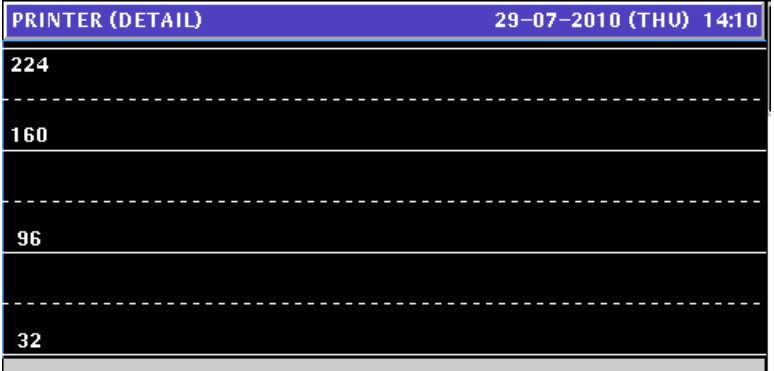
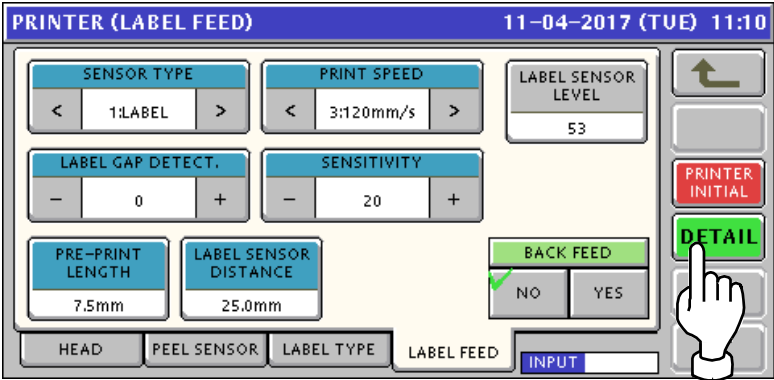

7.6 CALIBRATION

1. Press "CALIBRATION" field on the screen to display CALIBRATION screen.

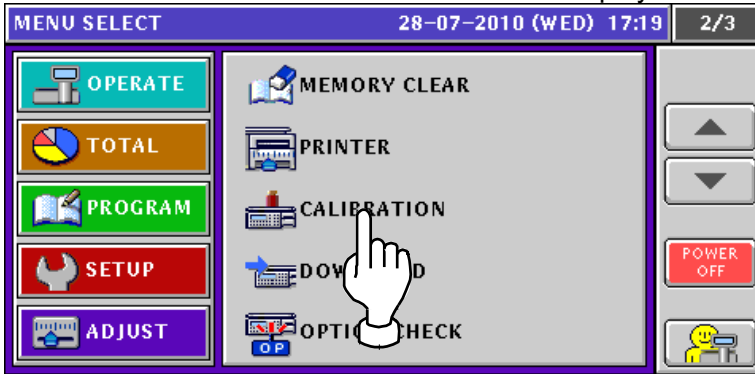

2. Press [CAPACITY] button to select the weighing capacity of the scale.

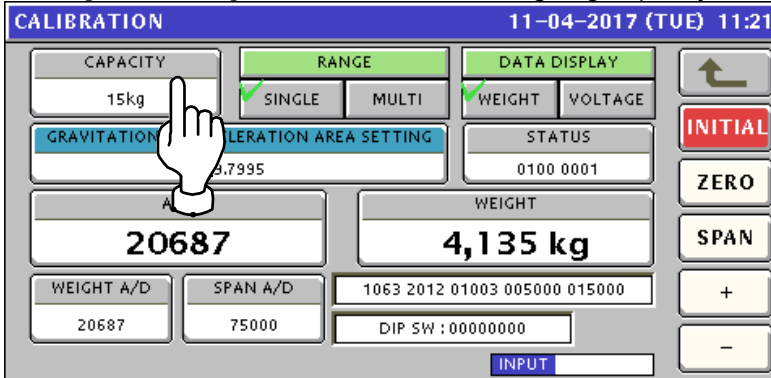

<CAPACITY>
 0: 15kg
 1: 30kg
 2: 30lb
 3: 60lb

3. Press [ZERO] button to perform zero point adjustment. Then, the WEIGHT displays field shows "0.000kg" or "0.00lb". Check that the value in A/D display field is "20000" and SPAN A/D display field shows "75000" at this time.

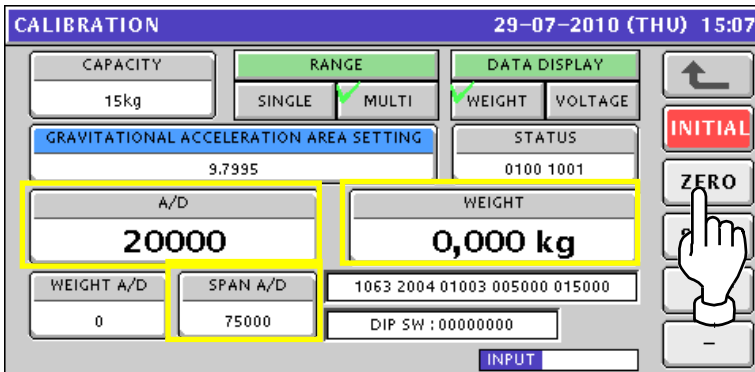

RANGE	Press to select either "SINGLE" or "MULTI" field.
DATA DISPLAY	Press to select either "WEIGHT" or "VOLTAGE" field.
AREA SET	Enter a desired numeric value and press this field.

4. Place the weights of the same weight as the upper limit of the weighing capacity on the weigh platter.

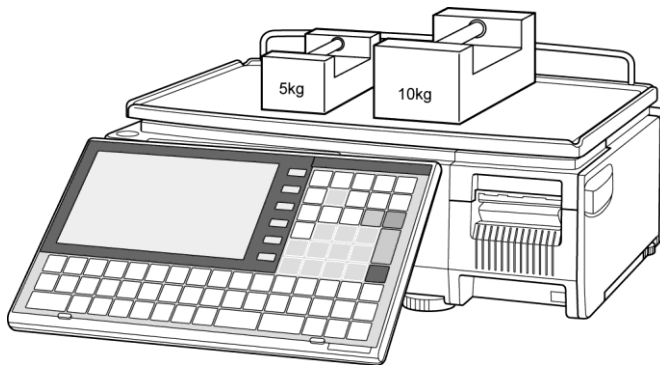

5. Press [SPAN] button when displaying values are stabilized. Then, check that A/D display field shows "95000", and SPAN A/D display field shows "75000".

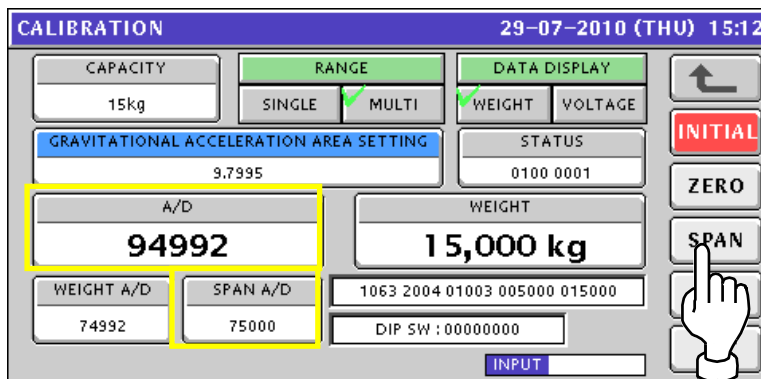

6. If A/D and SPAN A/D values are not "95000" and "75000" respectively, remove the weights from the platter.

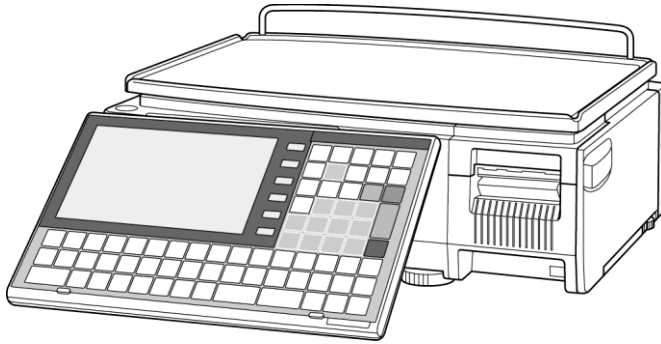

Then, place them on the platter again and press [SPAN] button to check that A/D display field shows "95000", and SPAN A/D display field shows "75000".

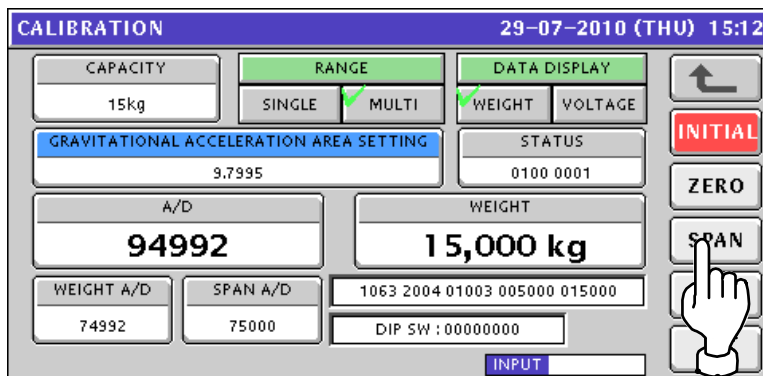
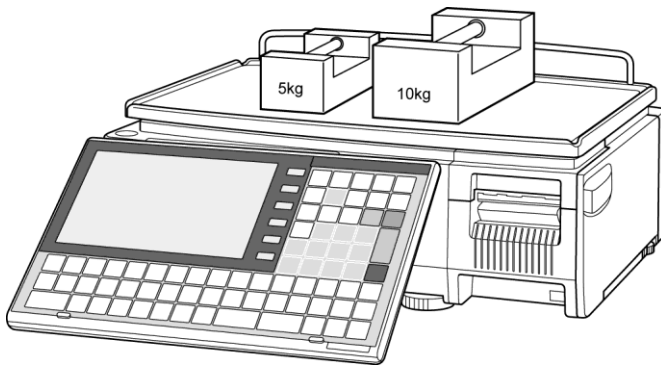

7. Repeat steps 3 through 5 above several times until A/D display field shows "95000", and SPAN A/D display field shows "75000".

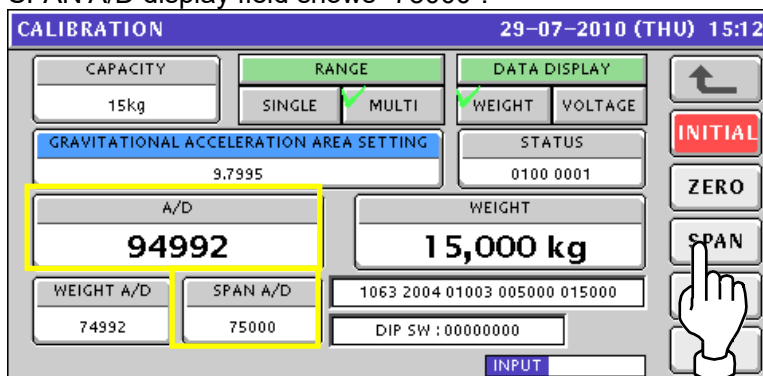

8. To memorize the adjusted span value, press Memory button located on the main board inside of the machine with a nonconductive and thin material such a wooden stick through the hole on the upper case.

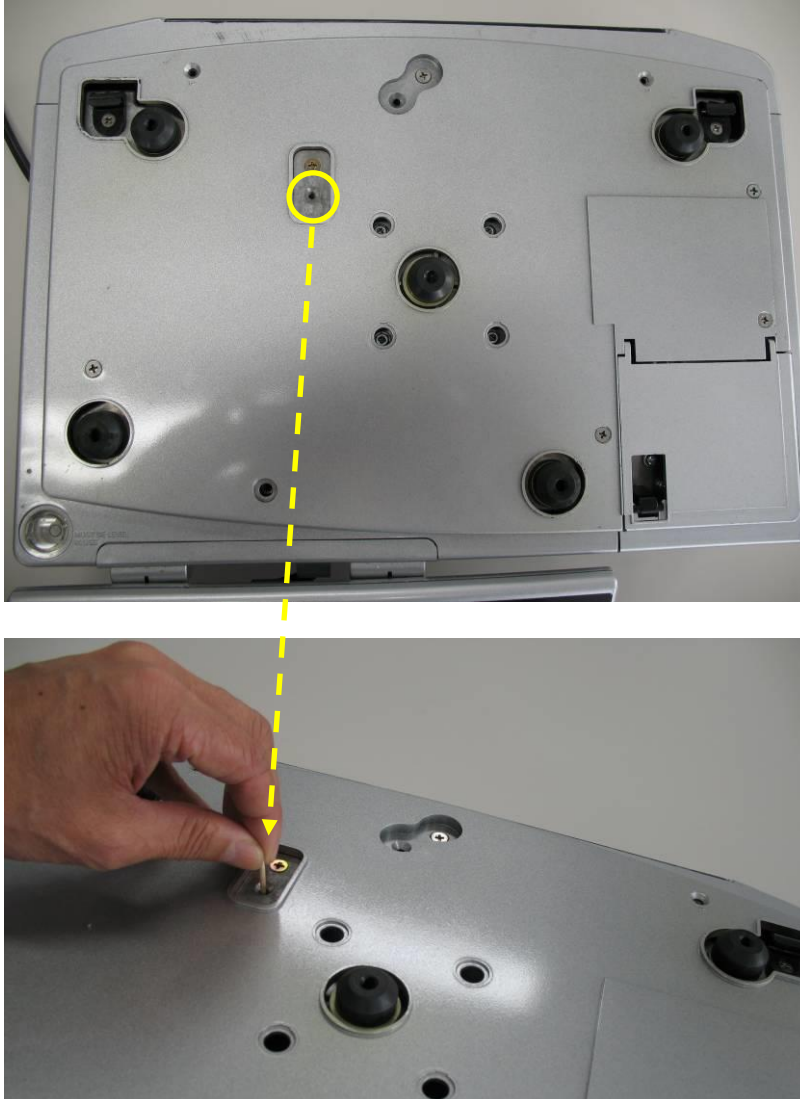

7.7 Downloading

Before down-loading data from the USB memory, make sure that the USB memory is inserted into the USB port located in the connector cover of the main body.

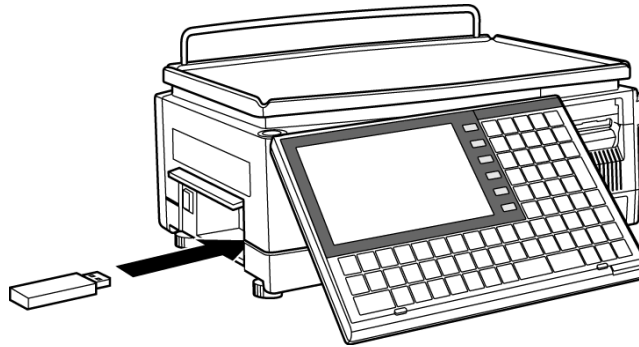

1. Press "DOWNLOAD" field on the screen to display DOWNLOAD (MAIN) screen.

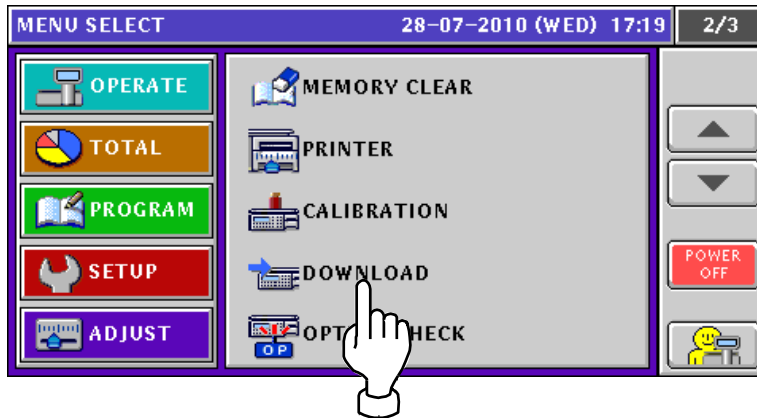

- 2-1. When loading data from the main memory to the USB memory, press to select [MAIN>USB] button and press [EXECUTE] button.

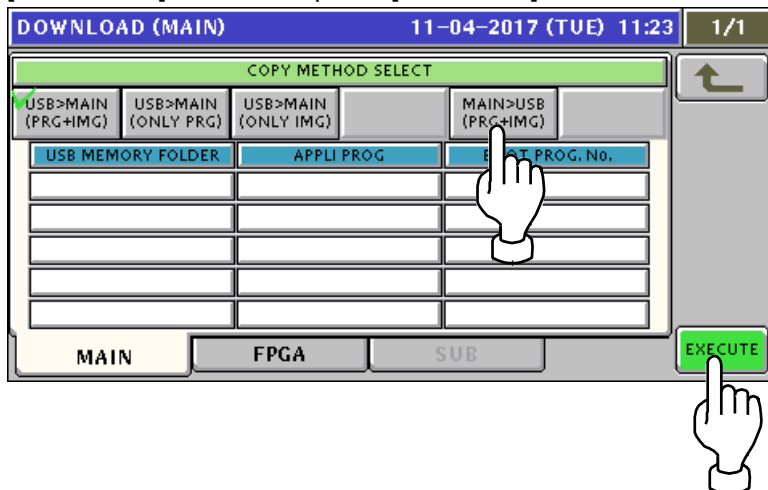

2-2. The following confirmation screen appears. Then, press [EXEC] button for execution.

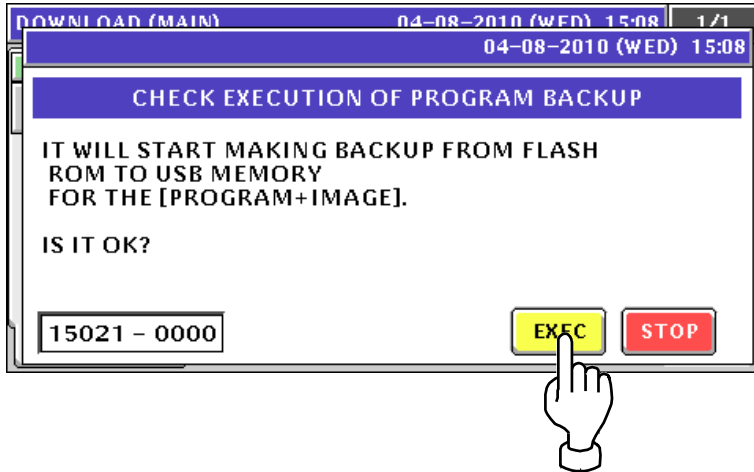

2-3. The progress screen appears.

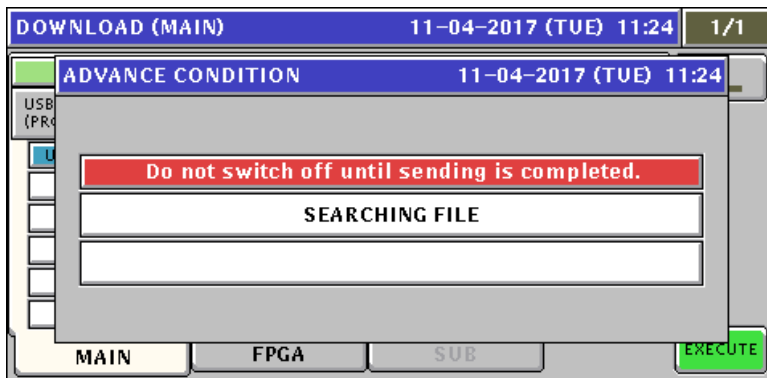

The beep sounds when completed.

3-1. When loading data from the USB memory to the main memory, press to select one of [USB>MAIN] buttons and press [EXECUTE] button.

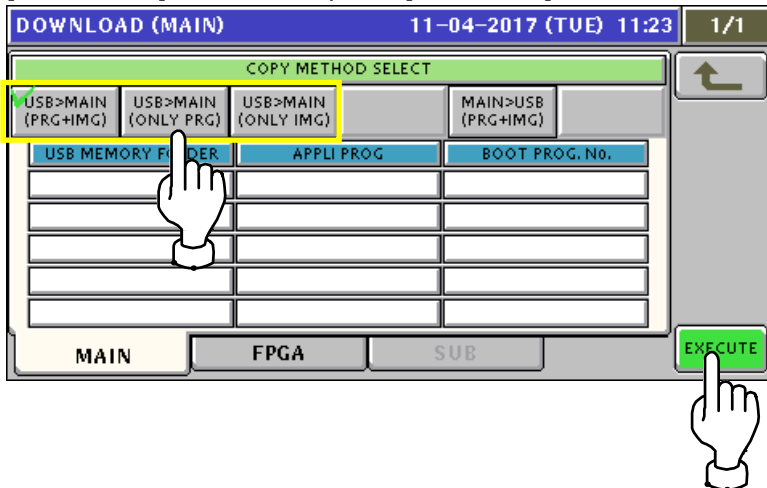

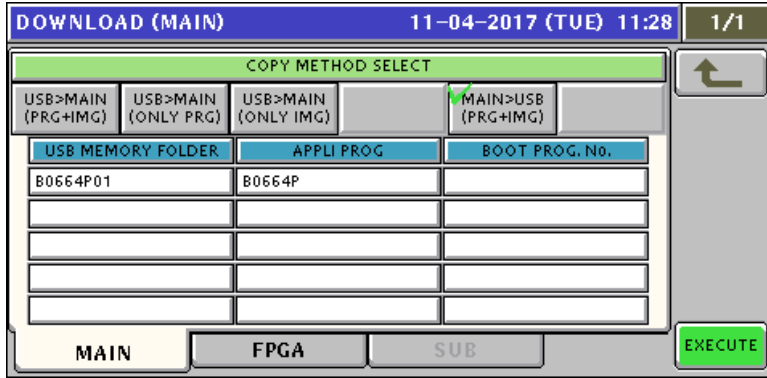
3-2. DOWNLOAD (MAIN) screen appears.

Press to select desired folders.

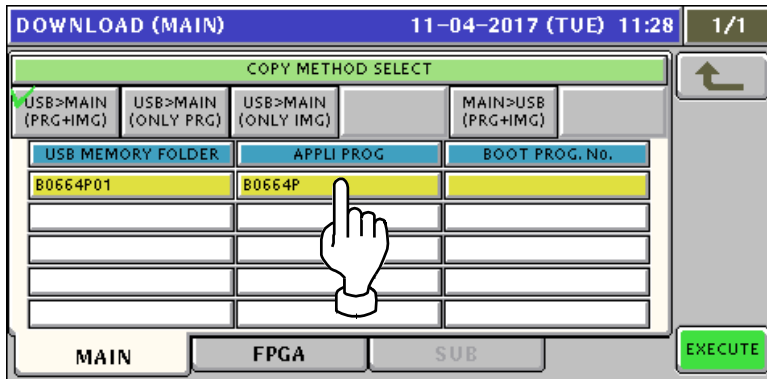
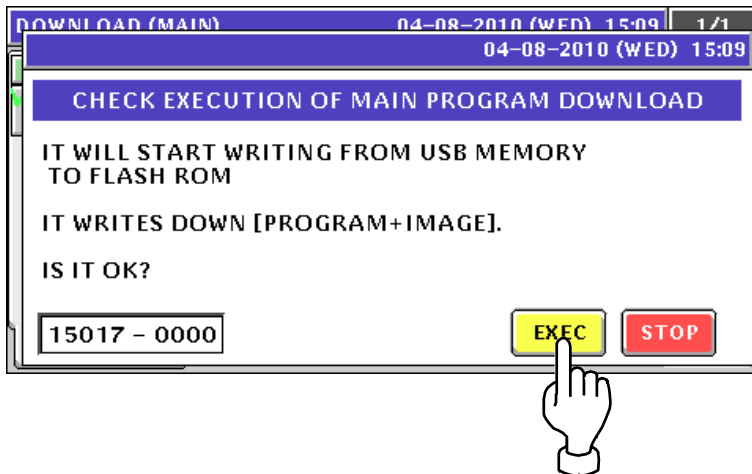
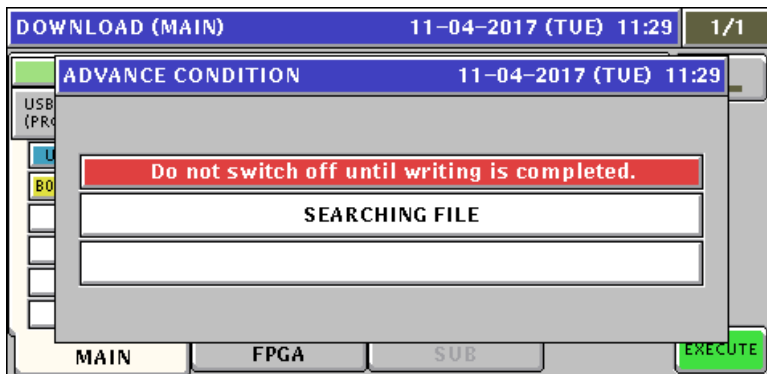
**3-3.** The following confirmation screen appears. Then, press [EXEC] button for execution.**3-4.** The progress screen appears.

3-5. The following message screen appears.

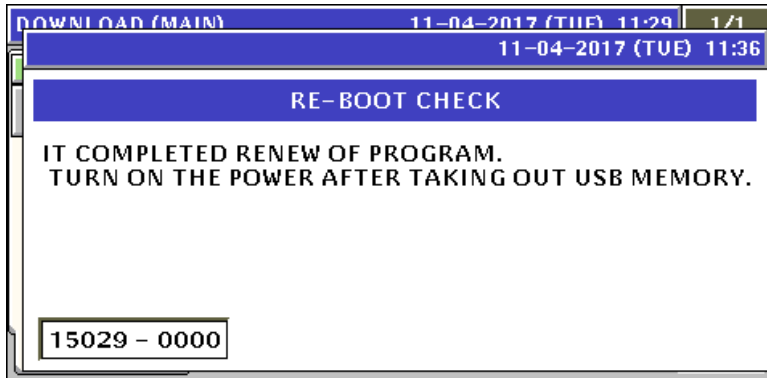

Then, pull out the USB from the port, and turn the power OFF and ON.

7.8 OPTION CHECK

1. Press "OPTION CHECK" field on Menu Select screen.

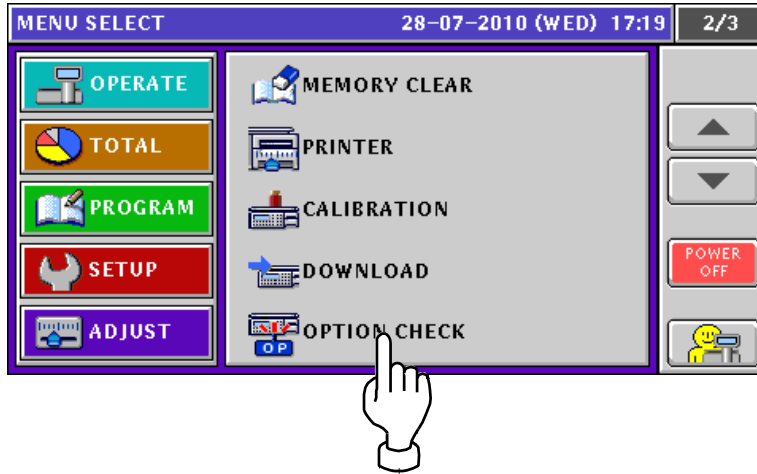

2. OPTION CHECK (USB) screen appears.
Press [EXECUTE] button to perform a memory test.

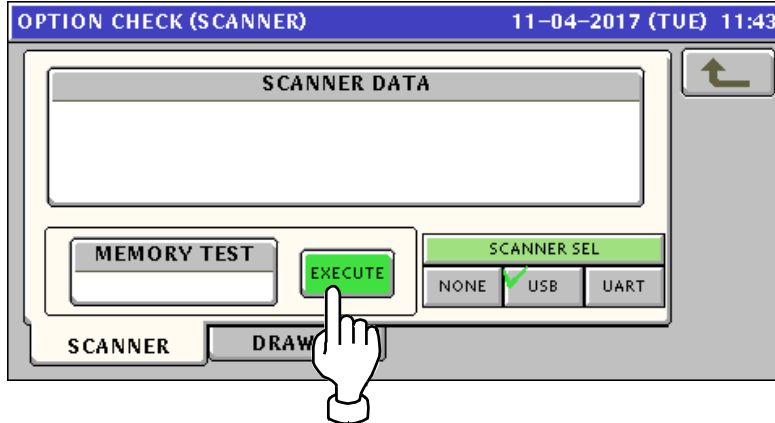

"OK" message appears when the memory test has been completed.

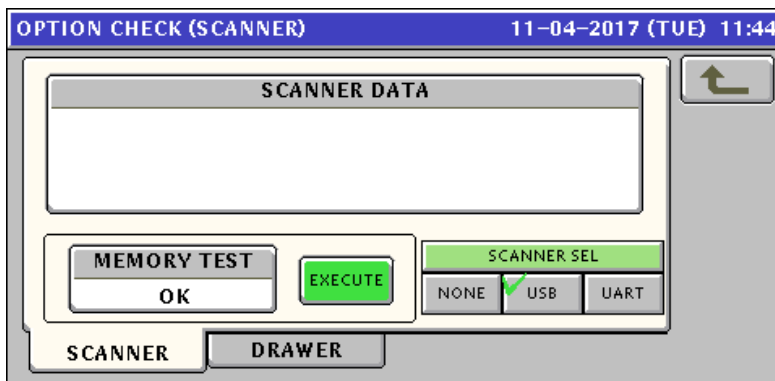

- 3. Press "DRAWER" tab to display OPTION CHECK (DRAWER) screen. Then, press [EXECUTE] button for each drawer port.

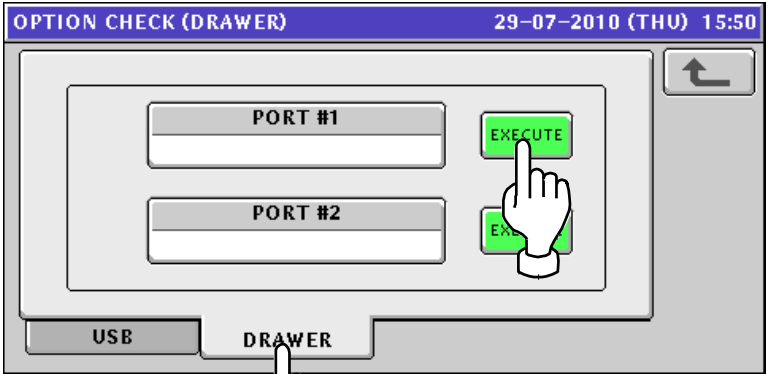

"EXECUTION" message appears.

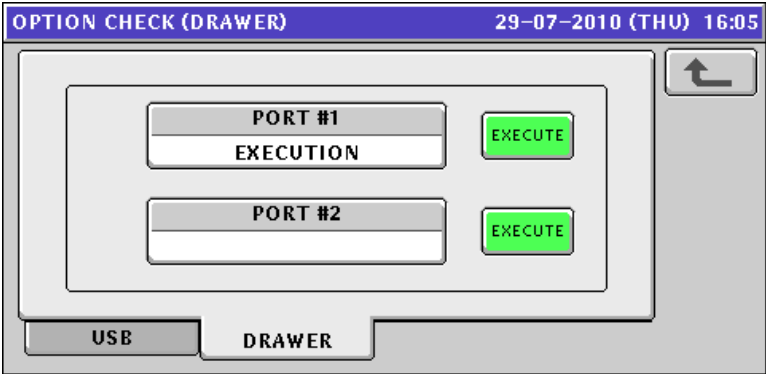

The beep sounds when the execution has been completed.

7.9 DISPLAY CAPTURE

- 1. Press "DISPLAY CAPTURE" field on the screen.

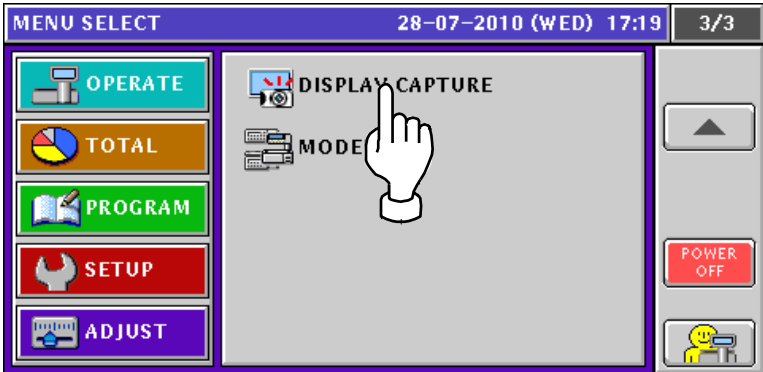

- 2. Press to select a desired field to decide whether or not to capture screen data.

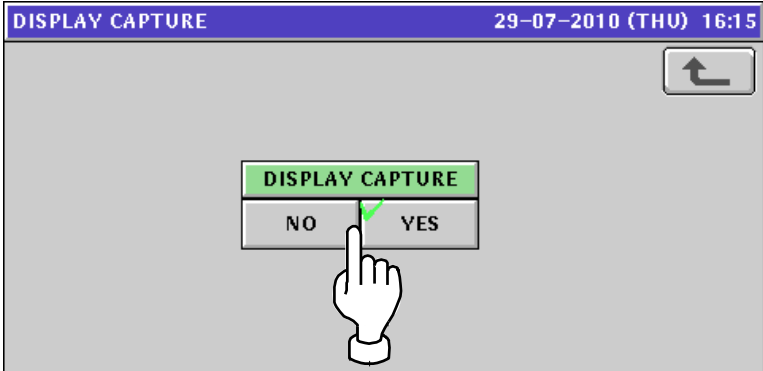

7.10 MODEL setting

1. Press "MODEL" field on the screen.

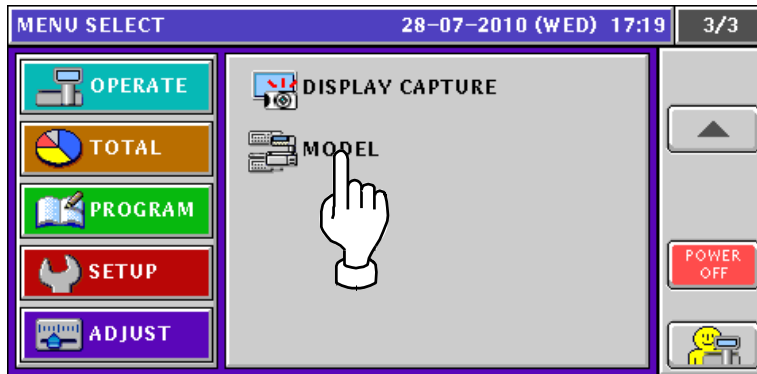

2. MODEL screen appears.

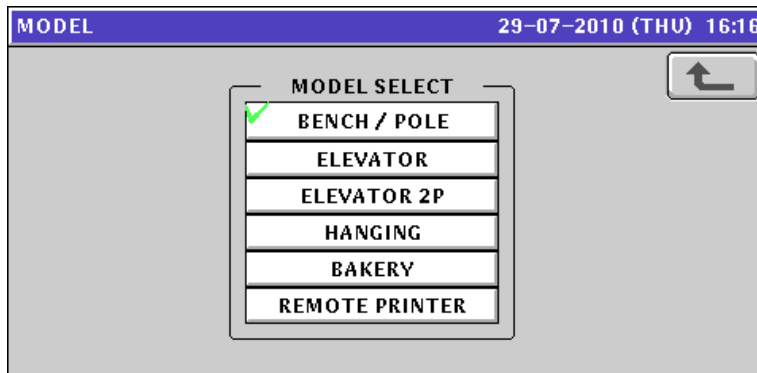

3. Press to select a desired model.

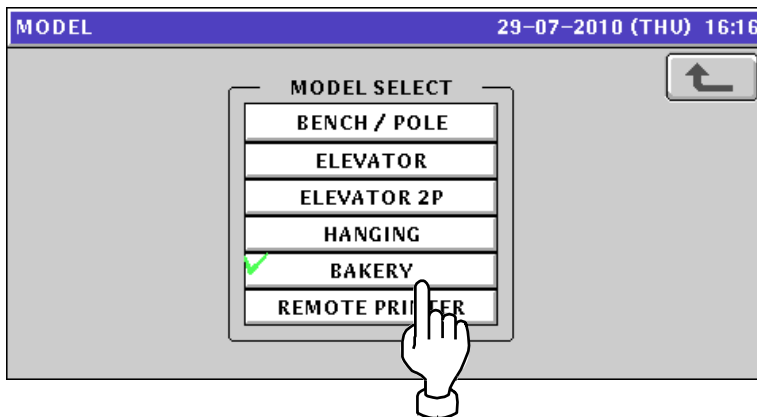

Chapter 8 Error screens

8.1 ERROR ID Nos. 105 to 116

ID NO.	TITLE	TEXT
105	INITIALIZATION FAILED	MAKE MEMORY INITIALIZATION
106	BATTERY IS FAULT	BATTERY SWITCH IS OFF OR NO MORE BATTERY
107	TOUCH PANEL ADJUSTMENT IS NOT COMPLETED YET	SET UP WITH (TOUCH PANEL) MODE
108	CLOCK SETTING IS NOT COMPLETED YET	SET UP WITH (CLOCK MODE)
109	PRINTER 1 INITIALIZATION WAS NOT DONE YET	INITIALIZE PRINTER 1
110	MACHINE SETTING IS NOT COMPLETED	SET UP WITH (MACHINE SELECTION) MODE
111	THE DISPLAY CONFIREMATION IS NOT COMPLETED.	PLEASE SET IT ON [DISPLAY CONFIRMATION] SCREEN OF THE ADJUSTMENT MODE.
112	THE CONFIRMATION OF THE KEY OPERATION IS NOT COMPLETED.	PLEASE SET IT ON [KEY] SCREEN OF THE ADJUSTMENT MODE.
113	PRINTER 2 ERROR	PLEASE SET IT ON [COMMUNICATION CHECK] SCREEN OF THE ADJUSTMENT MODE.
114	THE DATA COMPOSTION IS DIFFERENNT.	PLEASE INITIALIZE THE MEMORY.
116	THE COUNTRY HAS NOT BEEN SELECTED.	PLEASE SELECT THE COUNTRY.

8.2 ERROR ID Nos. 202 to 295

ID NO.	TITLE	TEXT
202	PLU MASTER IS NOT PROGRAMMED	PLU No. [*] IS NOT PROGRAMMED. CHECK PLU No.
203	POSP MASTER IS NOT PROGRAMMED	POP No. [*] IS NOT PROGRAMMED. DELETE IT?
204	ORIGIN MASTER IS NOT PROGRAMMED	COUNTRY OF ORIGIN No. [*] IS NOT PROGRAMMED. DELETE IT?
205	PRIMARY MATERIAL MASTER IS NOT PROGRAMMED	MATERIAL No. [*] IS NOT PROGRAMMED. DELETE IT?
206	STORAGE CONDISTION MASTER IS NOT PROGRAMMED	PRESERVATION WAY No. [*] IS NOT PROGRAMMED. DELETE IT?
207	TEMPERATURE MASTER IS NOT PROGRAMMED	TEMPERATURE No. [*] IS NOT PROGRAMMED. DELETE IT?
212	FREE1 MASTER ISN'T REGISTERED	FREE1 No. [*] ISN'T PROGRAMMED. DELETE IT?
213	FREE2 MASTER ISN'T REGISTERED	FREE2 No. [*] ISN'T PROGRAMMED. DELETE IT?
214	FREE3 MASTER ISN'T REGISTERED	FREE3 No. [*] ISN'T PROGRAMMED. DELETE IT?
215	FREE4 MASTER ISN'T REGISTERED	FREE4 No. [*] ISN'T PROGRAMMED. DELETE IT?
216	FREE5 MASTER ISN'T REGISTERED	FREE5 No. [*] ISN'T PROGRAMMED. DELETE IT?
219	STORE MASTER IS NOT PROGRAMMED	STORE No. [*] IS NOT PROGRAMMED. CHECK STORE No.
221	TARE LIMIT OVER (MAX 5998g)	RE-PROGRAM TARE WEIGHT. IF YOU RELEASE ERROR
222	TARE WEIGHT IS 0g	SET TARE WEIGHT
223	COMMENT MASTER IS NOT PROGRAMMED	COMMENT No. [*] IS NOT PROGRAMMED. DELETE IT?
224	LABEL SETTING MASTER IS NOT PROGRAMMED	LABEL No. [*] IS NOT PROGRAMMED. WANT TO PROGRAM AS DEFAULT?
229	FILE SYSTEM IS ABNORMAL	CHECK FILE CONTENTS
259	CALORY MASTER IS NOT PROGRAMMED	CAROLY No. [*] IS NOT PROGRAMMED. DELETE IT?
266-000	FILE INPUT ERROR	THERE IS FILE THAT FAILED IN INPUT.
266-001	FILE INPUT ERROR	FAILED IN RECONSTRUCTION OF SRAM DATA

ID NO.	TITLE	TEXT
267-000	FILE OUTPUT ERROR	THERE IS FILE THAT IS FAILED IN OUTPUT.
267-001	FILE OUTPUT ERROR	FAILED IN SRAM DATA BACK UP
268-000	FILE DELETE ERROR	THERE IS MASTER THAT FAILED IN DELETING.
268-001	FILE DELETE ERROR	FAILED IN SRAM DATA DELETE
268-002	FILE DELETE ERROR	IT FAILED IN DATA DELETE.
268-003	FILE DELETE ERROR	THERE IS DATA THAT FAILED IN DELETING.
271	INITIALIZE ERROR	THERE IS MASTER THAT FAILED IN INITIALIZATION
273	ABNORMAL	THERE IS ISSUE THAT HAS DIGNOSYS RESULT AS ABNORMAL.
274-000	ABNORMAL	THERE IS ISSUE THAT HAS DIGNOSIYS RESULT AS ABNORMAL.
274-001	ABNORMAL	IT CANCELED TOTAL DIGNOSYS PROCESS WITH FOLLOWING REASON. - IT FAILED IN DIGYNOSYS START PROCESS
274-002	ABNORMAL	IT CANCELED TOTAL DIGNOSYS PROCESS WITH FOLLOWING REASON. - IT FAILED IN GETTING IT.
274-003	ABNORMAL	IT CANCELED TOTAL DIGNOSYS PROCESS WITH FOLLOWING REASON. * IT FINISHED DIGNOSYS PROCESS WITHIN TIME.
281	TARE LIMIT OVER (MAX 5.998kg)	RE-PROGRAM TARE WEIGHT. IF YOU RELEASE ERROR
282	TARE WEIGHT IS 0kg	SET TARE WEIGHT
283	TARE LIMIT OVER (MAX 9.99lb)	RE-PROGRAM TARE WEIGHT. IF YOU RELEASE ERROR
284	TARE WEIGHT IS 0lb	SET TARE WEIGHT
286	FREE 6	
287	FREE 7	
288	FREE 8	
289	FREE 9	
290	FREE 10	

ID NO.	TITLE	TEXT
291	FREE 11	
292	FREE 12	
293	FREE 13	
294	FREE 14	
295	FREE 15	

8.3 ERROR ID Nos. 312 to 396

ID NO.	TITLE	TEXT
312-000	LABEL IS REMAINING	* LABEL IS REMAINING. REMOVE LABEL
312-001	LABEL IS REMAINING	REMOVE LABEL ON APPLICATOR.
313	PRINTER THERAML HEAD IS UP	* THERMAL HEAD IS UP. SET THERMAL HEAD
316	MARK DOWN PRICE IS MORE THAN ORIGINAL PRICE	CHECK PRICE. NORMAL PRICE[* \$] MARK DOWN PRICE[* \$]
317	VARIOUS PRICE IS LOWER THAN ORIGINAL PRICE	CHECK PRICE. NORMAL PRICE[* \$] VARIOUS PRICE[* \$]
318	MARK DOWN UNIT PRICE IS LESS THAN ORIGINAL PRICE.	CHECK UNIT PRICE. NORMAL UNIT/PRICE[* \$] MARK DOWN UNIT PRICE[* \$]
319	PRODUCTION FOR TARGET IS COMPLETED	CHECK TARGET No. CLEARS TARGET No.
321	PRICE IS NOT PROGRAMMED	ENTER PRICE
339	LOWER VALUE IS LESS THAN FIXED WEIGHT	IF YOU CHANGE FIXED WEIGHT [* g] TO [* g]
342	POS CODE IS NOT PROGRAMMED	POS CODE IS NOT PROGRAMMED AFTER PROGRAMMING IT
343	POS CODE IS NOT PROGRAMMED	POS CODE IS NOT PROGRAMMED. BARCODE CAN NOT BE PRINTED.
347-000	THERMAL HEAD IS WORN OUT	IT WORN OUT WHERE IT DOES NOT EFFECT ON PRINTING. NO PROBLEM ON PRICING LABEL. DO YOU WANT TO CHECK? PRESS (EXEC) TO CHECK. DOES NOT CHECK (STOP).
347-001	THERMAL HEAD IS WORN OUT	IT IS WORN OUT SIDE OF FORMAT YOU NEED TO CHANGE THERAMAL HEAD. DO YOU WANT TO CHECK? START CHECKING WITH (EXEC). (STOP) DO NOT CHECK
347-002	THERMAL HEAD IS WORN OUT	IT IS NOT PRITNING BARCODE CORRECTLY. CHANGE THERMAL HEAD. YOU CAN NOT DO THE WORK.
351	LABEL IS REMAINING	REMOVE LABEL
356	THERE IS NO CF CARD	CHECK CF CARD.
357	THERE IS NO DICTIONARY FILE	CHECK CF CARD.

ID NO.	TITLE	TEXT
361	POWER IS ON	CHECK SCALE FOR STARTING PRODUCTION.
396	NO USB MOMORY	CHECK USB MEMORY

8.4 ERROR ID Nos. 703 to 715

ID NO.	TITLE	TEXT
703	PRINTER 1 HAS PROBLEM	NO SPACE FOR PRINTING QUE. WAIT 10 SEC AFTER TURNING OFF THE MACHINE.
710-001	NO LABEL FOR PRINTER 1	CHANGE LABEL FOR PRINTER 1 1. UP THERMAL HEAD
710-002	NO LABEL FOR PRINTER 1	CHANGE LABEL FOR PRINTER 1 1. OPEN FRONT COVER
711-000	LABEL SIZE ERROR FOR PRINTER 1	REMOVE LABEL FOR PRINTER 1 PRESS (FEED) TO PRINT OUT LABEL.
711-001	LABEL SIZE ERROR FOR PRINTER 1	REMOVE LABEL FOR PRINTER 1 PRINT OUT LABEL BY (FEED) KEY.
711-002	LABEL SIZE ERROR FOR PRINTER 1	REMOVE LABEL FOR PRINTER 1 1. OPEN FRONT COVER
713	TOO MANY CHARACTERS ON FORMAT FOR PRINTER 1	FAILED IN [*].
714-000	REMAINING LABEL ON PRINTER 1	REMOVE LABEL
714-001	REMAINING LABEL ON PRINTER 1	REMOVE LABEL
714-002	REMAINING LABEL ON PRINTER 1	REMOVE LABEL
715-000	THERMAL HEAD IS WORN OUT FOR PRINTER 1	NEED TO CHANGE THERMAL HEAD
715-001	THERMAL HEAD IS WORN OUT FOR PRINTER 1	THERMAL HEAD IS WORN OUT BUT DOES NOT EFFECT ON PRINTING YOU CAN CONTINUE LABELLING. DO YOU WANT TO MAKE FURTHER CHECK? PRESS (EXEC) TO CHECK. DOES NOT MAKE (STOP) CHECK.
715-002	THERMAL HEAD IS WORN OUT FOR PRINTER 1	THERMAL HEAD IS WORN OUT WITHIN FORMAT. NEED TO CHANGE THERMAL HEAD. DO YOU WANT TO MAKE FURTHER CHECK? (EXEC) TO CHECK. (STOP) NOT TO CHECK
715-003	THERMAL HEAD IS WORN OUT FOR PRINTER 1	CAN NOT PRINT BARCODE CORRECTLY. CHANGE THERMAL HEAD. CAN NOT PRINT LABEL. CAN NOT DO LABELLING.
715-004	THERMAL HEAD IS WORN OUT FOR PRINTER 1	THERMAL HEAD IS WORN OUT BUT DOES NOT EFFECT ON PRINTING YOU CAN CONTINUE LABELLING. DO YOU WANT TO MAKE FURTHER CHECK? PRESS (EXEC) TO CHECK. DOES NOT MAKE (STOP) CHECK.

ID NO.	TITLE	TEXT
715-005	THERMAL HEAD IS WORN OUT FOR PRINTER 1	THERMAL HEAD IS WORN OUT WITHIN FORMAT. NEED TO CHANGE THERMAL HEAD. DO YOU WANT TO MAKE FURTHER CHECK? (EXEC) TO CHECK. (STOP) NOT TO CHECK
715-006	THERMAL HEAD IS WORN OUT FOR PRINTER 1	CAN NOT PRINT BARCODE CORRECTLY. CHANGE THERMAL HEAD. CAN NOT PRINT LABEL. CAN NOT DO LABELLING.
715-007	THERMAL HEAD IS WORN OUT FOR PRINTER 1	THERMAL HEAD IS WORN OUT BUT DOES NOT EFFECT ON PRINTING YOU CAN CONTINUE LABELLING. DO YOU WANT TO MAKE FURTHER CHECK? PRESS (EXEC) TO CHECK. DOES NOT MAKE (STOP) CHECK.
715-008	THERMAL HEAD IS WORN OUT FOR PRINTER 1	THERMAL HEAD IS WORN OUT WITHIN FORMAT. NEED TO CHANGE THERMAL HEAD. DO YOU WANT TO MAKE FURTHER CHECK? (EXEC) TO CHECK. (STOP) NOT TO CHECK
715-009	THERMAL HEAD IS WORN OUT FOR PRINTER 1	CAN NOT PRINT BARCODE CORRECTLY. CHANGE THERMAL HEAD. CAN NOT PRINT LABEL. CAN NOT DO LABELLING.

8.5 ERROR ID Nos. 1601 to 1624

ID NO.	TITLE	TEXT
1601	SPAN ADJUSTMENT FOR SCALE IS NOT COMPLETED	RE-SET SPAN
1624	DATA SET ERROR	SET DATA ONEDIGIT DIFFERENT ERROR. ONE DIGIT CHECK.

8.6 ERROR ID Nos. 1801 to 1824

ID NO.	TITLE	TEXT
1801	CHECKING CLOCK SETTING	ADJUST CLOCK.
1824-000	TARGET ACHIEVED	TARGET ACHIVED
1824-001	CHANGE PLU	DO YOU WANT TO CHANGE?
1824-002	EXIT SALES MODE	DO YOU WANT TO SAVE TO TARGET VALUE?

8.7 ERROR ID No. 2001

ID NO.	TITLE	TEXT
2001	NO SPACE FOR MEMORY CARD	CHANGE IT TO NEW MEMORY CARD OR DELETE UNNECESSARY FILE IN MEMORY CARD BY PC

8.8 ERROR ID Nos. 9608 to 9690

ID NO.	TITLE	TEXT
9608	IT IS NOT PROGRAMMED IN PRESERVATION WAY MASTER	TEMPERATURE MASTER No. [*] IS NOT PROGRAMMED. CHECK THE CONTENTS FOR MASTER.
9609	IT IS NOT PROGRAMMED IN PRESERVATION WAY MASTER	PRESERVATION No. [*] IS NOT PROGRAMMED. CHECK THE CONTENTS FOR THE MASTER.
9653	IT IS NOT PROGRAMMED IN CALORY MASTER	CALORY No. [*] IS NOT PROGRAMMED. CHECK THE CONTENTS FOR MASTER.
9690	MEMORY IS FULL	DATA CAN NOT BE RENEWED. IT DELETES UNNECESSARY MASTER IN THE MASTER MACHINE.

Chapter 9 Appendix







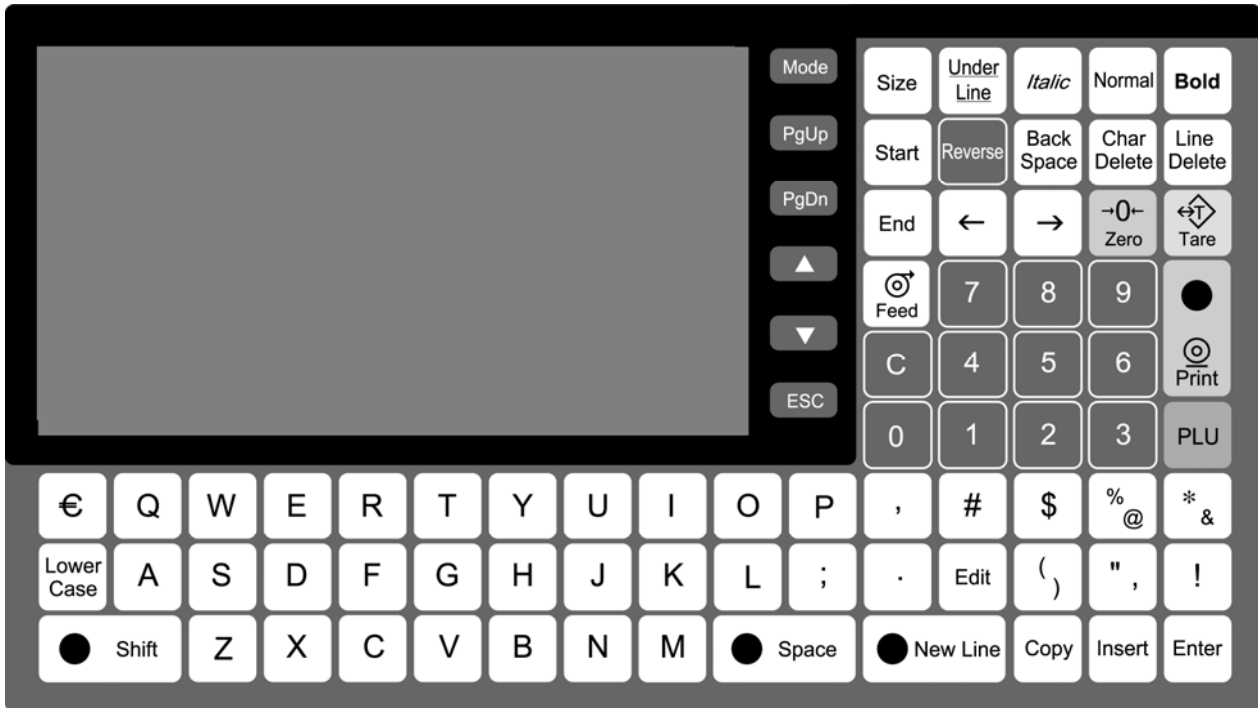









9.1 Text editing

9.1.1 Operation panel and key functions

9.1.1.1 Operation Panel

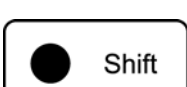

9.1.1.2 Keys for Text Editing

	Used to delete a character by moving the cursor back by one character.		Used to select a font size for a text displayed on the screen.
	Used to delete a character at the place where the cursor is positioned.		Used to move the cursor to right. Also, used to select characters for changing the style.
	Used to delete a line text.		Used to move the cursor to left. Also, used to select characters for changing the style.
	Used to specify a normal character style.		Used to select either lower-case or upper-case character mode for a text to be entered.
	Used to specify a bold character style.		Used to copy the original data to the current data.
	Used to specify an Italic character style.		Used to finalize editing a text.
	Used to specify an underlined character style.		Used to begin a new character line.
	Used to specify a reversed character.		Used to select either a lower-case or upper-case mode for a character to be entered.
	Used to enter a space at the place where the cursor is positioned.		

9.1.2 Normal character registration

1. Confirm that the text edit screen is displayed.

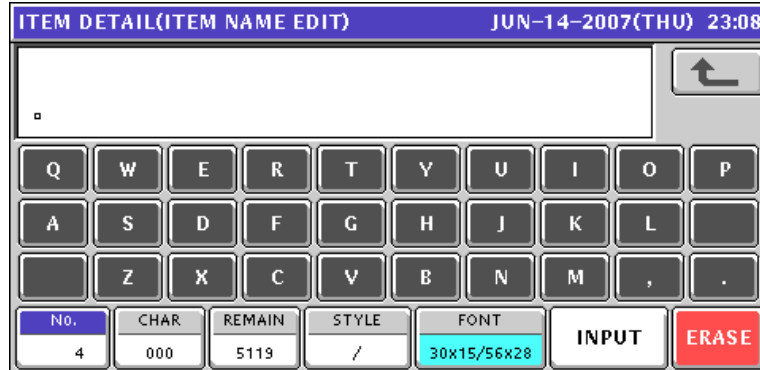

Select a desired character size by using [Size] key on the key sheet.



The selected size is displayed in "FONT" display field.

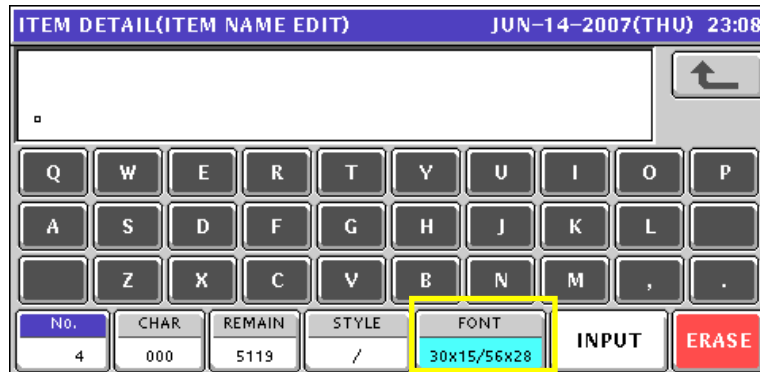

2. Press [Lower Case] key on the key sheet to select whether to use upper-case characters or lower-case characters.



- 3. Enter desired characters using alpha-numeric keys on the key sheet or the screen.



Upper-case characters

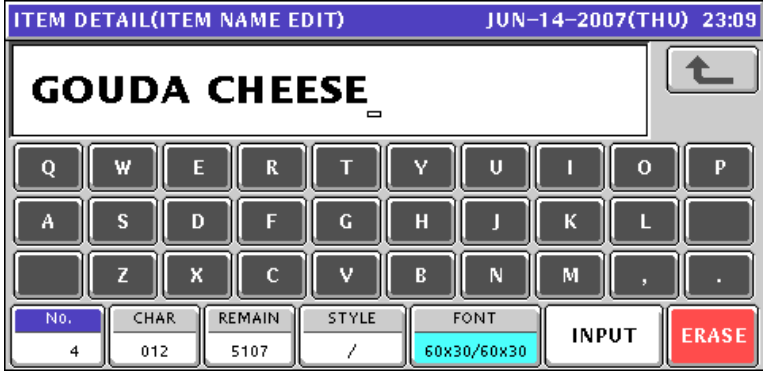

Lower-case characters

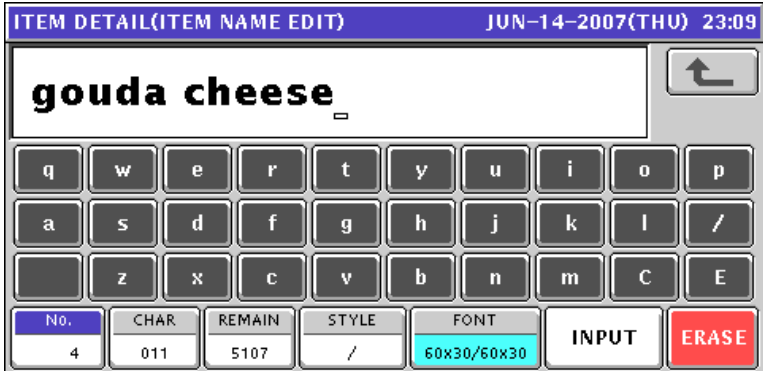

- 4. To change to a new line, press [New Line] key on the key sheet.



Enter desired characters.

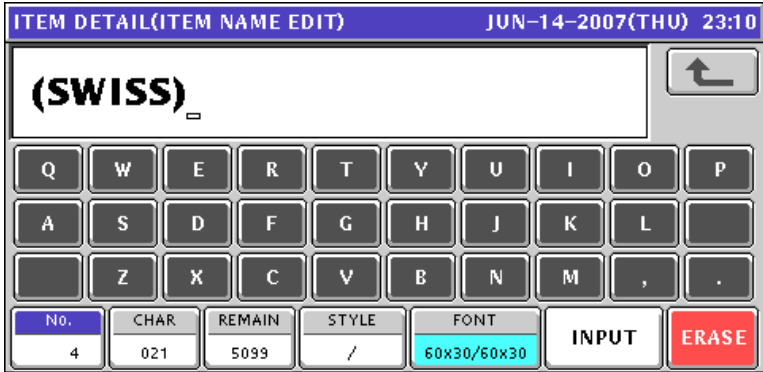

- To finalize the editing, press [ESC] key on the key sheet.



The confirmation screen appears. Then, press [SAVE] button to save the data.

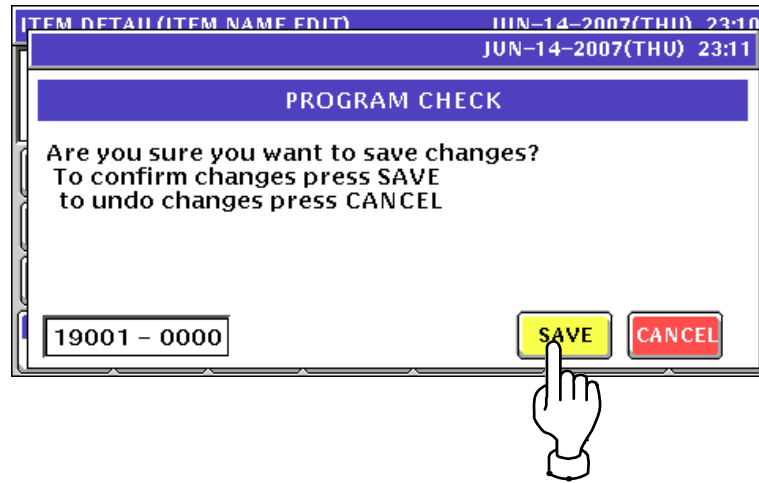

9.1.3 Special character registration

- 1. Confirm that the text edit screen is displayed.

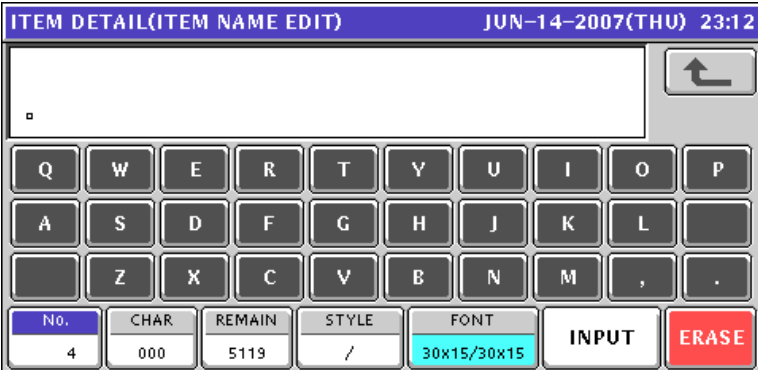

- 2. To select a desired character style using the following keys.



The selected style is displayed in "STYLE" display field.

EXAMPLE

Select reversed characters.

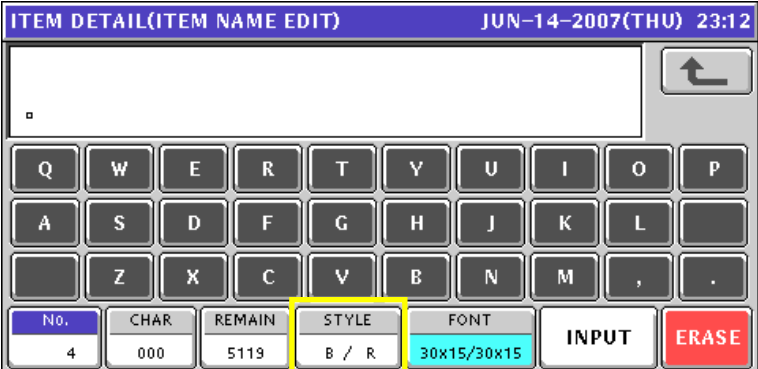

- 3. Enter desired characters using alpha-numeric keys on the key sheet or the screen.



4. Press [ESC] key on the key sheet.



The confirmation screen appears. Then, press [SAVE] button to save the data.

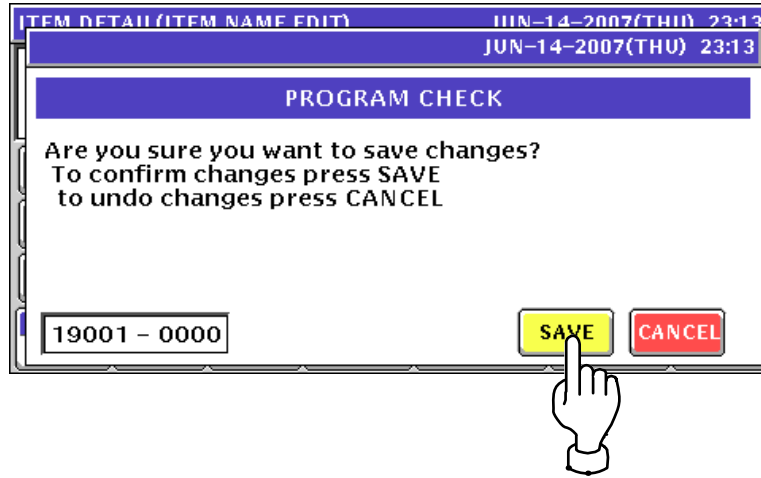

9.1.4 Line deletion

- 1. Confirm that the text edit screen for a desired PLU is displayed.



- 2. To delete the character line, press [Line Delete] key on the key sheet.

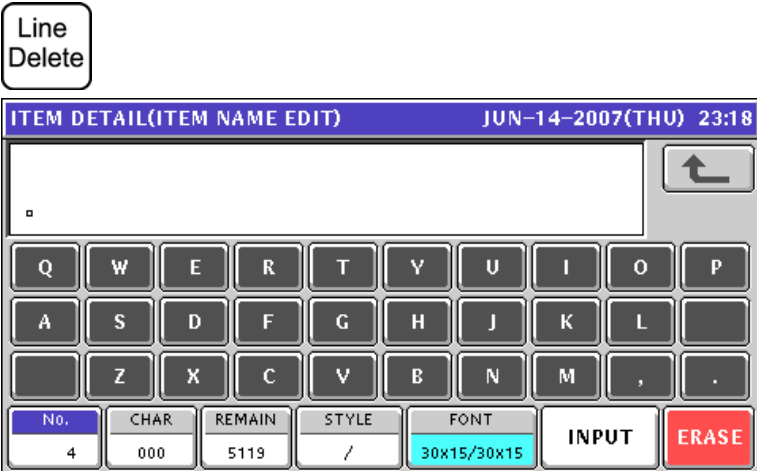

- 3. Press [ESC] key on the key sheet.



The confirmation screen appears. Then, press [SAVE] button to save the data.

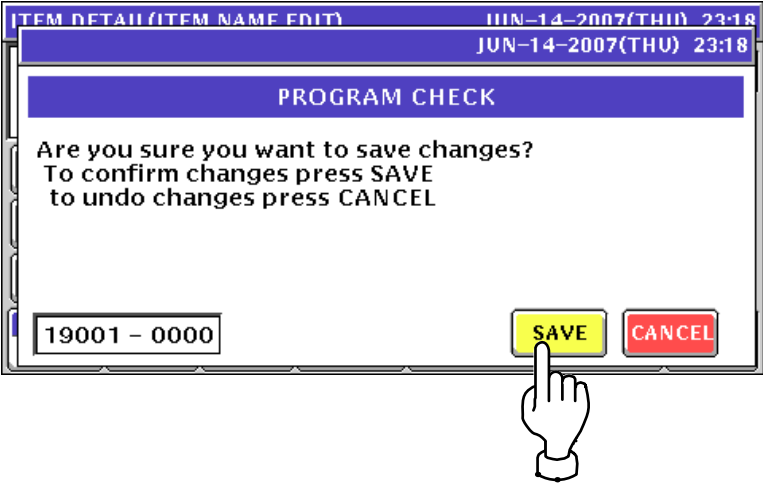

9.1.5 Character deletion

- 1. To Make a correction for a misspelled word, move the cursor to a place where misspelling is made by using [→] or [←] key.

EXAMPLE "GAUDA" → "GOUDA"

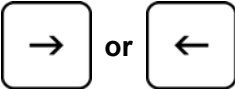

- 2. Press [Character Delete] key on the key sheet to delete the misspelled character.



3. Enter the correct character using the alpha-numeric keys.

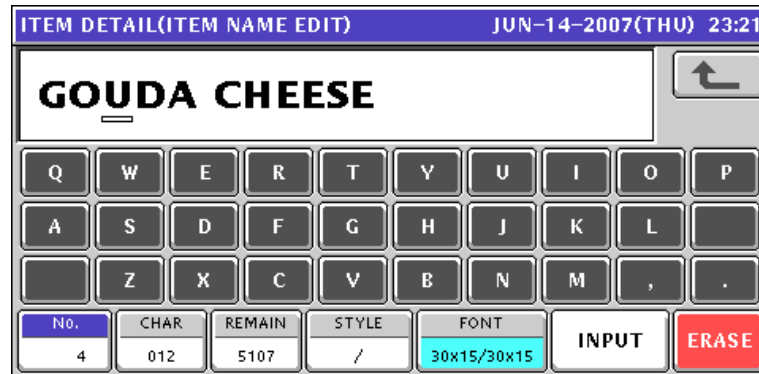

4. Press [ESC] key on the key sheet.



The confirmation screen appears. Then, press [SAVE] button to save the data.

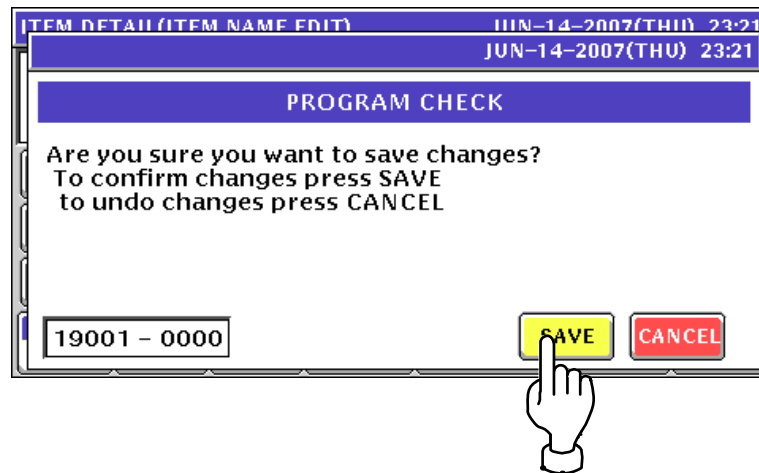

9.1.6 Character backspacing

- 1. To delete a wrong character that was just entered, press [Back Space] key on the key sheet to move the cursor back by one character.

EXAMPLE "E" → "A"

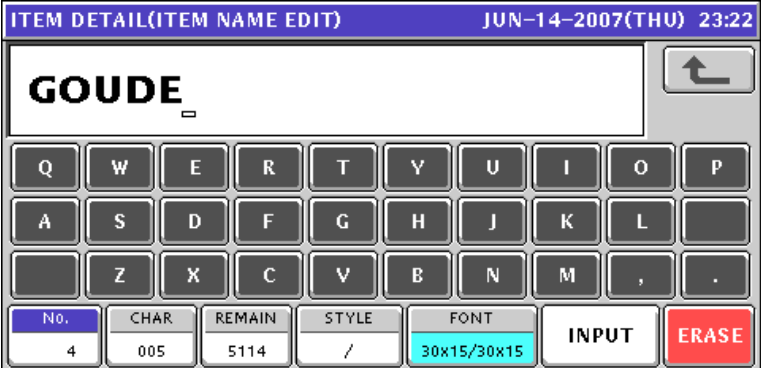

Back Space

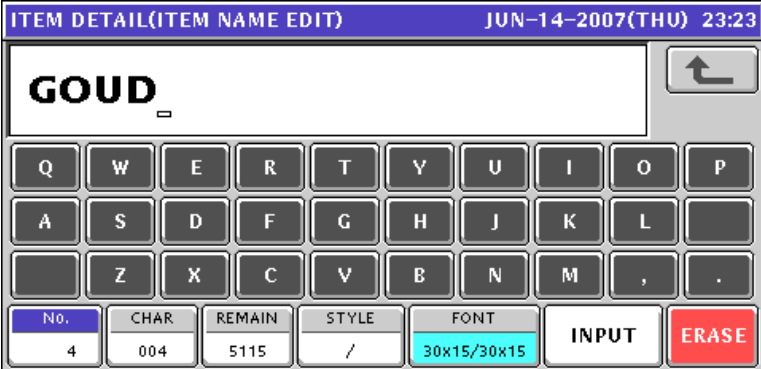

- 2. Enter a correct character.

A

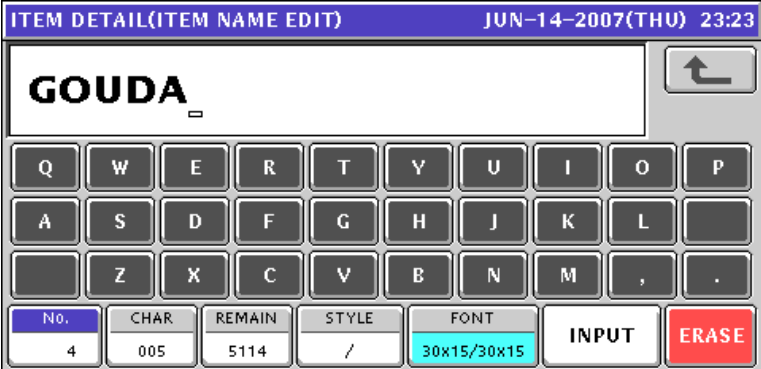

3. Complete the text.



4. Press [ESC] key on the key sheet.



The confirmation screen appears. Then, press [SAVE] button to save the data.

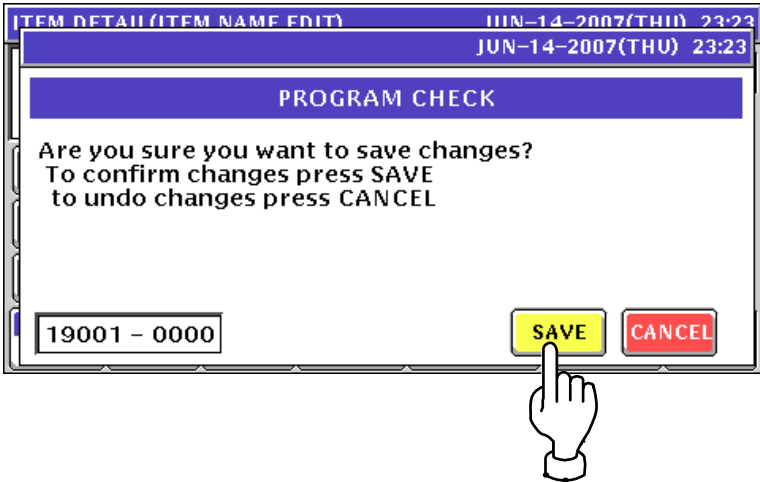

9.2.2 Elevated type

9.2.2.1 Single printer

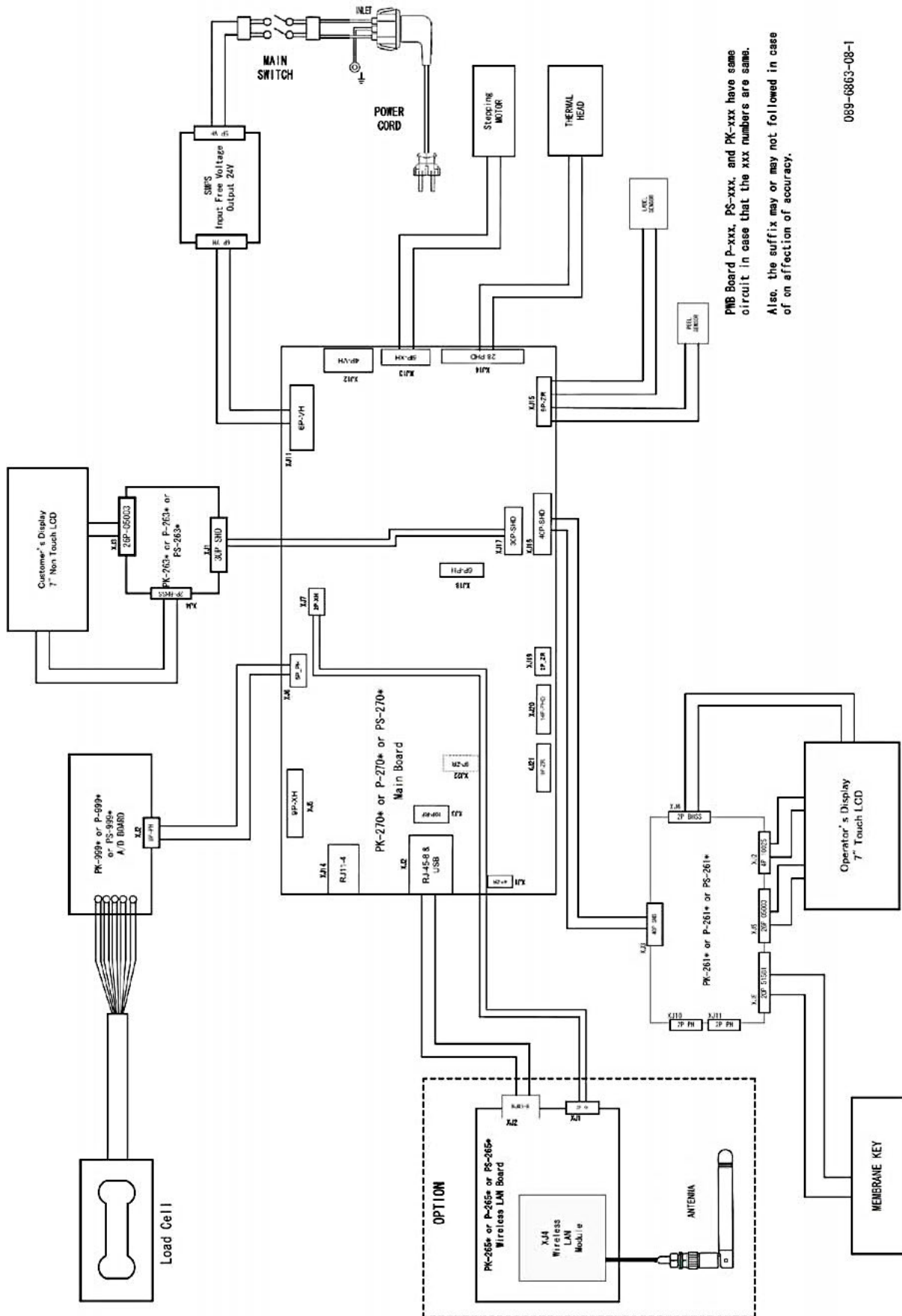

PWB Board P-xxx, PS-xxx, and PK-xxx have same circuit in case that the xxx numbers are same. Also, the suffix may or may not followed in case of an affection of accuracy.

089-6863-08-1



© Rice Lake Weighing Systems Content subject to change without notice.

230 W. Coleman St. • Rice Lake, WI 54868 • USA USA: 800-472-6703 • International: +1-715-234-9171