

# JB1010

---

*Ten-Channel Junction Box*

## Installation Manual

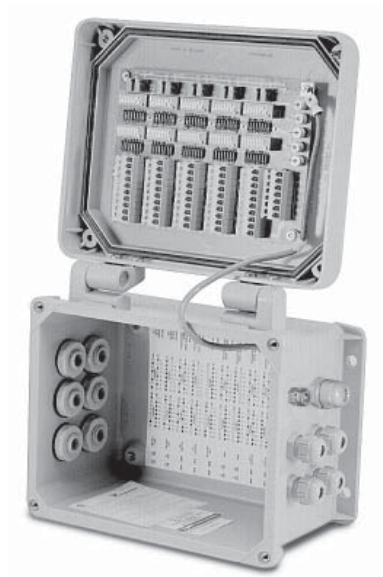

**RICE LAKE**<sup>®</sup>  
WEIGHING SYSTEMS  
To be the best by every measure<sup>®</sup>

36329



# Contents

|  |          |
|--|----------|
| <b>1.0 Introduction.....</b>   | <b>1</b> |
| <b>2.0 Mounting the Enclosure.....</b>                                     | <b>2</b> |
| <b>3.0 General Wiring Guidelines.....</b>                                  | <b>2</b> |
| <b>4.0 Wiring for New Systems .....</b>                                    | <b>3</b> |
| <b>5.0 Trimming Load Cell Output.....</b>                                  | <b>4</b> |
| <b>5.1 Trimming Individual Cells.....</b>                                  | <b>4</b> |
| <b>5.2 Trimming Cells in Sections.....</b>                                 | <b>4</b> |
| <b>5.3 Trimming Both Individual Cells and Sections (Full Feature).....</b> | <b>5</b> |
| <b>6.0 Transient Protection System.....</b>                                | <b>6</b> |
| <b>7.0 Switchbank SWA and SWB 1-8 Switch Functions.....</b>                | <b>7</b> |
| <b>8.0 Using the JB1010 In an Existing System.....</b>                     | <b>8</b> |
| <b>9.0 Schematic Drawing of Connector Section (Two Load Cells) .....</b>   | <b>9</b> |



Authorized distributors and their employees can view or download this manual from the Rice Lake Weighing Systems distributor site at [www.rlws.com](http://www.rlws.com).

# 1.0 Introduction

The JB1010 is a summing junction box and trimming device for up to ten strain gauge load cells. In new applications that use a single junction box, the JB1010 can be custom configured to fit many unique applications. It allows either signal or excitation trimming of three load cell arrangements: individual load cells, pairs of load cells in sections, or a combination of individual/and paired load cells. It allows use of an odd number of load cells without modification.

As a replacement board for existing applications in the field—even as part of a multiple junction box trimming network—the JB1010 can replace many boards. It is ideal as a single replacement product for many separate boards for truck scales, tank scales, and track scales. This product can be used in multiple configurations. Most of these configurations are used to match existing systems using multiple junction boxes.

When the JB1010 is used as a replacement for existing junction boxes, the configuration characteristics of the other trimming devices must be matched for proper operation. Help for determining the characteristics of existing devices will be found in Section 8.0, *Using the JB1010 in an Existing System*.

Standard JB1010 units have a local transient suppression network that provides zone protection against most lightning induced transients, particularly when used with cell wiring in metal conduit.

In addition to the NEMA 4 FRP junction box, the JB1010 is also available as a board-only product.

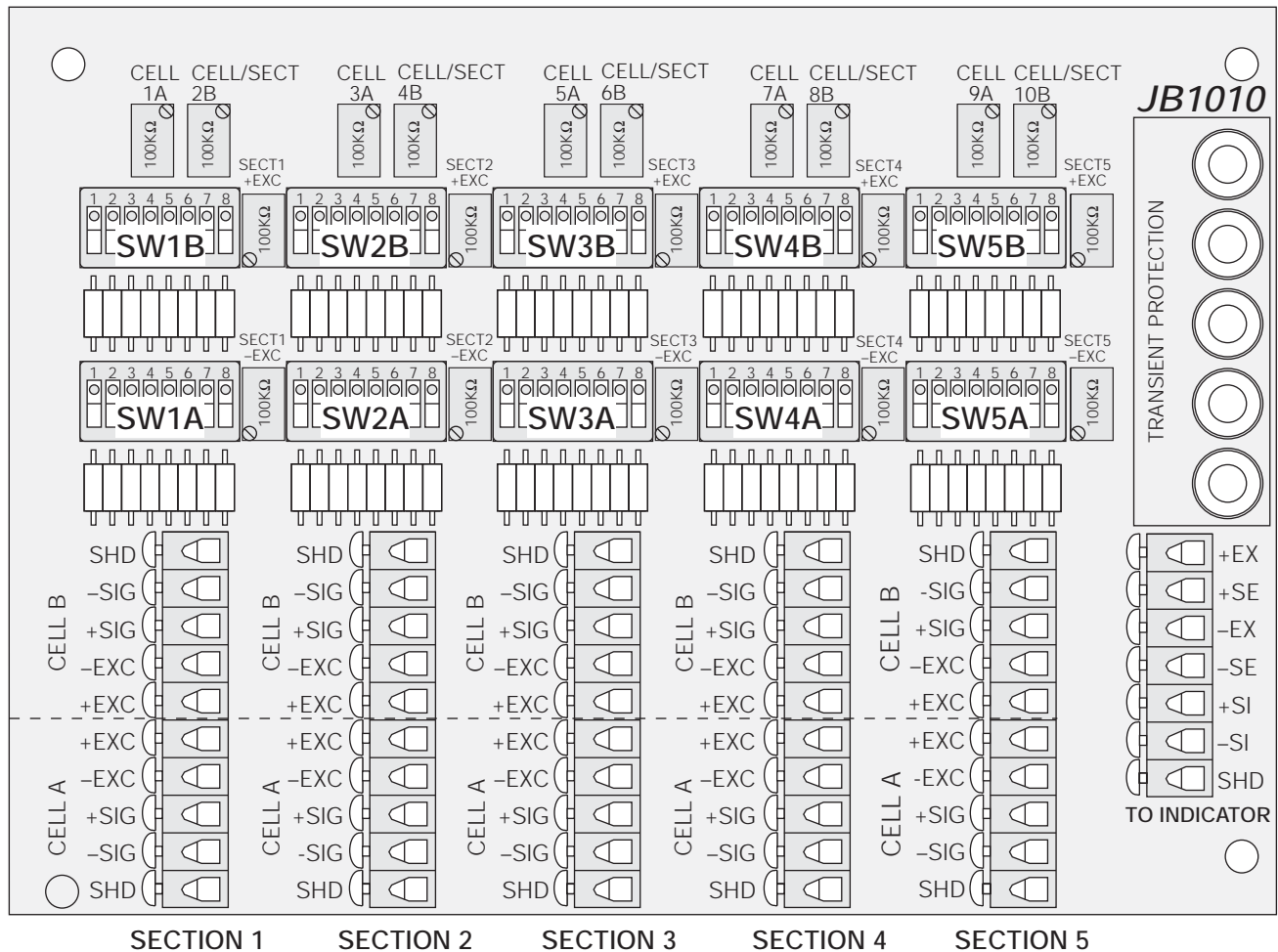
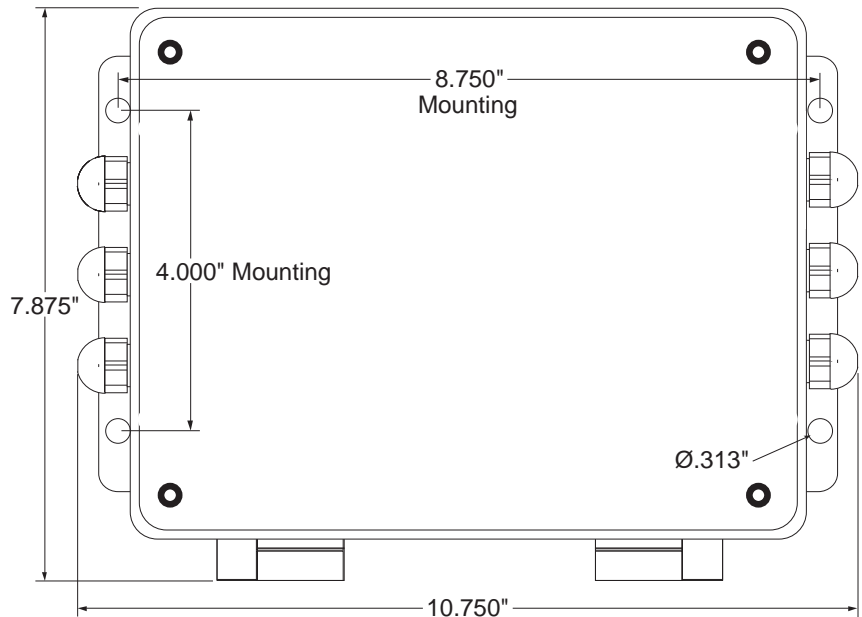

Figure 1-1. JB1010 Board

## 2.0 Mounting the Enclosure

The JB1010 has 4.0" x 8.75" mounting centers for #10 or 1/4" screws. Mount the enclosure for proper service access. Avoid mounting on weighbridges where vibration and shock loads may loosen connections and locations prone to flooding.

The standard JB1010 has waterproof nylon cord grips to seal the cables and provide strain relief. Cable diameters from 0.157" to 0.314" can be used with these grips. When installing the cables into the enclosure, leave the strain relief loose until the connections have been routed with the enclosure fully open. When completed, tighten the grips with a wrench to prevent water from wicking into the box. To prevent water and other contaminants from entering the junction box, fill any unused cable grips with post screw plugs; P/N 19538.



If cables will be exposed to fluids, bend a short downward loop in all cables near the cord grips so any fluids draining down the cables will drip off before reaching the junction box (see Figure 2-2).

Use a quality desiccant in the enclosure and replace it at least every six months. Replace it more often if the environment is very damp or is regularly wetted down.

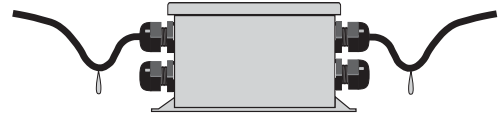

If using the transient protection grounding feature, install the fittings with a wrench and use an electrical grade lubricant such as WD-40® on threads and fittings. Connect the ground lug to a single system ground rod (if locally connected) or to the grounding lug on the AC transient protector for the indicator or load cell power supply.

## 3.0 General Wiring Guidelines

The JB1010 is a universal trimming board, designed to trim almost any set of new or existing load cells in nearly any configuration. To properly wire the JB1010, first determine what kind of application you have.

If the JB1010 is the only trimming junction box in a new system, continue on to the next page.

If the JB1010 replaces one or more boards in an existing system, skip to Section 8.0.

## Wire Preparation

The JB1010 uses spring-loaded, quick-connect wire terminals. These connectors are very reliable if used properly.

To prepare the wires, strip 3/8" of insulation from the individual wires. If the conductors are stranded wires, tin the ends of the wires using wire solder with a non-corrosive solder flux.

## Inserting the Wires into the Terminals

Push down on the plastic lever with a pen or small screwdriver to compress the spring. See Figure 3-1. Install the wire into the compression clamps. Push the wire into the connector until the wire is fully seated. Make sure the clamp is resting on the stripped portion of the wire and not on the insulation. Release the lever and pull on the wire to make sure it is secure.

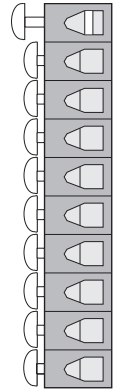

Figure 3-1.  
Wire Terminals

## 4.0 Wiring for New Systems

Use the following procedure to set up a new system.

1. Connect all cells with trimming disabled as shown in Figure 4-1.
2. Connect the cells to the junction box using the connectors marked Sections 1 to 5, Cell A and B. If pairs of load cells are to be trimmed in sections (as with truck or track scales), wire both cells to the same ten-position connector. If using less than ten cells, leave unused connectors empty.
3. If you have an odd number of load cells, connect the odd cell to a Cell A input unused cell connector. Configure that connector as shown in Figure 4-2. You must disable the trimming to any unused cell connectors, shown in Figure 4-1.
4. Connect the indicator cable to the terminal strip marked TO INDICATOR. Use six wire shielded cable and activate the remote sensing of the indicator. Remote sensing will compensate for resistance changes due to environmental changes.
5. Turn on the indicator. If the indicator reading appears stable, consider doing a temporary calibration. Set a known weight on the scale deck and perform a calibration sequence to set the sensitivity of the meter to about the final calibration required.

If the system fails to repeat to zero or exhibits instability, **you must fix the problem before continuing**. You cannot trim a system that will not repeat.

If all you want to do is connect the cells in parallel, you are finished. Do a final calibration of the system using the zero and span adjustments on the weight indicator.

6. If you want to trim the system for matched load cell output, go to Step 1 on the following page.

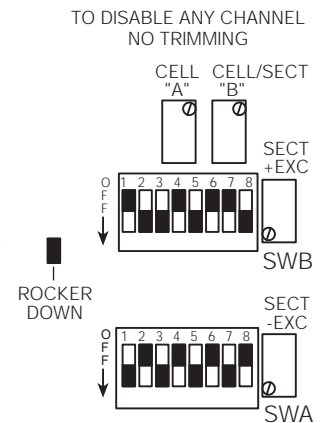

Figure 4-1.

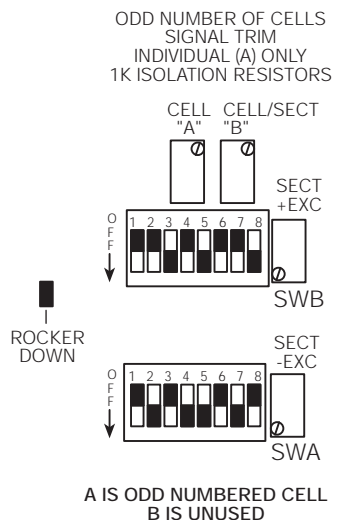

Figure 4-2.

## 5.0 Trimming Load Cell Output

### 5.1 Trimming Individual Cells

1. Determine what and how you want to trim. If the cells will be trimmed individually, we recommend a signal trim mode. While you can select either 2.5K $\Omega$  or 1K $\Omega$  isolation resistors, we recommend the 1K $\Omega$  resistors.

Engage trimming for only those terminals which have load cells connected. If using signal trim for individual cells with 1K $\Omega$  isolation resistors, configure the switches as shown in Figure 5-1.

If using a different trimming combination (2.5K $\Omega$  resistors, section trim, or excitation trim), see Section 7.0 *Complete Switch Settings Chart*.

2. Turn all potentiometers fully clockwise. This produces the maximum voltage (minimum trim) on all cells. Always begin with minimum trim; never “center the pots.”
3. Place a test weight on the scale directly over each load cell in turn to determine which cell has the lowest output. This can be determined by watching the display on the indicator. This cell will be used as the system reference and will not be trimmed.
4. Trim individual load cells by placing the test weight over each individual cell in turn. Turn the potentiometer for that cell counterclockwise until the reading produced by the cell matches that of the reference cell.

Trim odd-numbered cells using the potentiometers marked Cell A; trim even-numbered cells with the potentiometer marked Cell/Sect B. It doesn't matter what the absolute cell outputs are, as long as they are the same.

5. Readings are somewhat interactive, and you may have to repeat the trimming procedure to get extremely close matching of outputs.
6. Once the cell outputs are the same, do a final calibration of the system using the zero and span adjustments on the weight indicator.

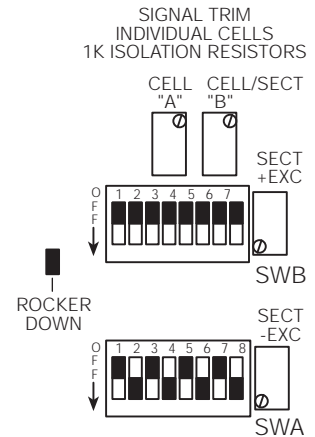

### 5.2 Trimming Cells in Sections

Trimming in sections assumes there are an even number of load cells to be trimmed in pairs. We recommend using the 1K $\Omega$  signal trim section mode shown in Figure 5-2 if possible.

In this and other configuration modes using both section and signal trim, the Cell/Sect B potentiometer trims both the A and B load cells. Turning the Cell/Sect B potentiometer counterclockwise decreases output and trims the section comprised of the two load cells wired to the connector below the SWA switchbank.

Remember to disable any unused channels as shown in Figure 4-1.

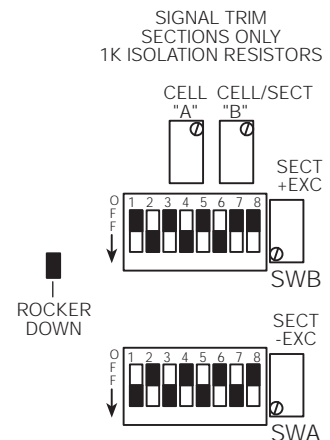
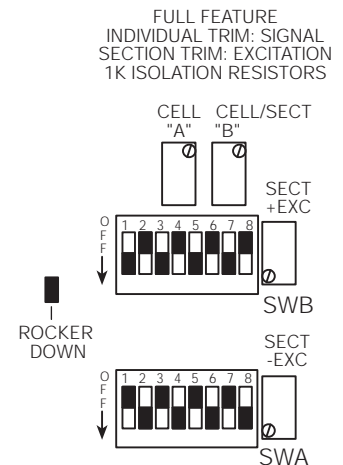

Figure 5-2.

### 5.3 Trimming Both Individual Cells and Sections (Full Feature)

The following is the trimming procedure for a new installation with 1K double isolation full loadcell signal and section excitation trim. All other types of calibration should be similar with only dipswitch changes for the required configuration.

1. Connect all loadcells to the J-Box.
  - Set dip switches SWB position 1, 3, 4, 5, 6, 7 ON, and 2 and 8 OFF.
  - Set dip switches SWA all in the ON position.
2. Perform a reference point calibration. The scale should be stable and return to zero after calibration. If it does not do this, correct the problem in the scale before attempting to do any trimming of the scale.
3. Enable the signal trim for all loadcells.
  - Set dip switches SWB all in the ON position.
  - Set dip switches SWA position 1, 3, 5, 7 ON, and 2, 4, 6, 8 OFF.
4. Using Pot A and Pot B for their respective cells, trim each loadcell by placing a test weight on the loadcell that is being trimmed in each section and trim it's respective pot so that it matches other weight reading of the other loadcell in that section pair. Do this to each section. The section weights do not have to match the actual test weight, just the other loadcell in that pair.
5. Enable excitation trim for all loadcells
  - Set dip switches SWB position 1 and 7 OFF.
6. Using the pot for sect +exe and sect -exe, trim each section with a test weight so that it matches the other sections by using a test weight. The value on your indicator may not match your test weight actual weight.
7. Perform a final calibration. The scale should return back to zero and repeat. Make any small adjustments as required.



#### Notes:

Loadcell A pot is a signal trim pot that can be set up as follows:

- with A2 and A4 OFF, do just the odd loadcell signal trim
- with A2, A4, A6, A8, and B2 ON, the pot will do section signal trim.

Loadcell B pot is a signal trim pot that can be set up as follows:

- with A6 and A8 OFF, do just the even loadcell signal trim.
- with A2, A4, A6, A8, and B8 ON, the pot will do section signal trim.

Section +exe pot adjust:

- with B7 OFF, pot will do section +exe trim

Section -exe pot adjust:

- with B1 OFF, pot will do section -exe trim



## **6.0 Transient Protection System**

---

The transient protection network uses gas tubes selected for low leakage to ground in a network that has been proven effective with load cells. Connect the ground stud on the junction-box enclosure to a suitable low impedance ground. If a local ground is used, make sure that it is a single ground rod and not a “network”. The best place to ground is to the ground lug on the side of the transient suppressor which protects the source of the excitation voltage. This keeps the system on a single point ground.

If the gas tubes are hit by lightning or transients related to lightning, they may begin to leak to ground. This problem usually shows up as instability, drift, or an overload or underload condition on the indicator. If this occurs, remove the ground wire and see if the problem persists. If it goes away, then the board may be bad or load cells may be damaged. Use a quality voltmeter with a nano-siemman conductivity range to find the leakage to ground and correct it. Gas tubes that fail while protecting against transients are intentionally sacrificial and not a warranty item. They are simply performing their function in the system.

If you think the board may be damaged, record the current DIP switch settings, then reset the DIP switches to disable all trimming as shown in Figure 4-1. Disconnect the ground wire from the JB1010. This effectively hooks all cells in parallel, disables all trim and isolation, and removes any leakage source to ground. If the system problems still persist, check the load cell cable and load cells for damage.

Return the switches to their previous positions you have marked down once the problem has been repaired. If new cells have been added, they must be trimmed as part of re-calibration.

# 7.0 Switchbank SWA and SWB 1-8 Switch Functions

NOTE: A is odd numbered cell, B is even numbered cell, unless otherwise noted.

|     |    |   |
|-----|----|---|
| SWA | A1 | Odd Loadcell -Sig Isolation Resistor Select<br>On 1K OHMS Isolation<br>Off 2.5K OHMS Isolation  |
|     | A2 | Odd Loadcell - Sig Isolation Resistor Bypass<br>On -Sig Isolation Resistor Bypassed (0K OHMS Isolation)<br>Off Isolation Resistor Selected by A1 Switch     |
|     | A3 | Odd Loadcell +Sig Isolation Resistor Select<br>On 1K OHMS Resistor Isolation<br>Off 2.5K OHMS Resistor Isolation  |
|     | A4 | Odd Loadcell +Sig Isolation Resistor Bypass<br>On +Sig Isolation Resistor Bypassed (0K OHMS Isolation)<br>Off Isolation Resistor Selected by A3 Switch      |
|     | A5 | Even Loadcell -Sig Isolation Resistor Select<br>On 1K OHMS Isolation<br>Off 2.5K OHMS Isolation   |
|     | A6 | Even Loadcell - Sig Isolation Resistor Bypass<br>On -Sig Isolation Resistor Bypassed (0K OHMS Isolation)<br>Off Isolation Resistor Selected by A5 Switch    |
|     | A7 | Even Loadcell +Sig Isolation Resistor Select<br>On 1K OHMS Resistor Isolation<br>Off 2.5K OHMS Resistor Isolation   |
|     | A8 | Even Loadcell +Sig Isolation Resistor Bypass<br>On +Sig Isolation Resistor Bypassed (0K OHMS Isolation)<br>Off Isolation Resistor Selected by A7 Switch     |
| SWB | B1 | Disable Section -Exe Trim<br>On Section -Exe Trim Off<br>Off Section -Exe Trim On   |
|     | B2 | Odd Loadcell Signal Trim Enable<br>On Odd Loadcell Trim Enabled<br>Off Odd Loadcell Signal Trim Disabled  |
|     | B3 | Section Loadcell -Sig Isolation Resistor Select<br>On 1K OHMS Resistor Section Isolation<br>Off 2.K OHMS Resistor Section Isolation                         |
|     | B4 | Section Loadcell - Sig Isolation Resistor Bypass<br>On -Sig Isolation Resistor Bypassed (0K OHMS Isolation)<br>Off Isolation Resistor Selected by B3 Switch |
|     | B5 | Section Loadcell +Sig Isolation Resistor Select<br>On 1K OHMS Resistor Section Isolation<br>Off 2.K OHMS Resistor Section Isolation                         |
|     | B6 | Section Loadcell +Sig Isolation Resistor Bypass<br>On +Sig Isolation Resistor Bypassed (0K OHMS Isolation)<br>Off Isolation Resistor Selected by B5 Switch  |
|     | B7 | Disable Section +Exe Trim<br>On Section +Exe Trim Off<br>Off Section +Exe Trim On   |
|     | B8 | Even Loadcell Signal Trim Enable<br>On Even Loadcell Trim Enabled<br>Off Even Loadcell Signal Trim Disabled   |

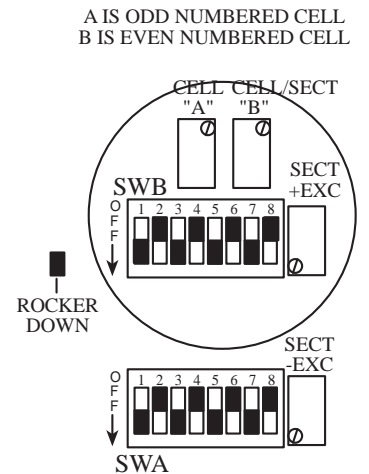
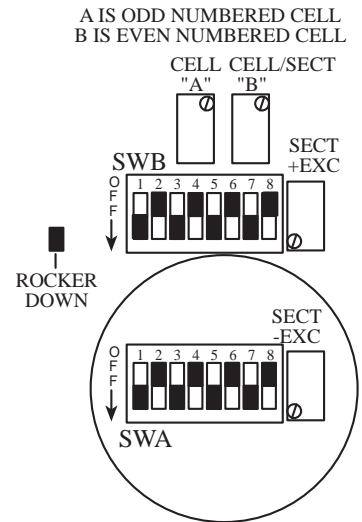

## **8.0 Using the JB1010 In an Existing System**

---

Large vehicle scales often have two, three, or four junction boxes connected into a network. When servicing these scales, you don't have a choice of what's going to fail. When one of the junction boxes fails, it shuts the whole scale down. The service technician rarely has the right board with him to replace a third party junction board. As a universal board, the JB1010 can usually serve as a replacement.

The JB1010 can be adapted to match almost any common (and some uncommon) summing boards. To do this, you can study the old board, look for isolation resistors, and see how the trimming works. Sometimes, however, you have to make an intelligent guess.

Most large trimming boards use signal trim. If you see a large number of resistors on the circuit board, it is a good bet that the board is a signal trim board. Most signal trim boards either have 2.5K $\Omega$  or 1K $\Omega$  isolation resistors. If the board has both individual cell and section trimming, then there are often two sets of isolation resistors.

Use the following strategy to identify and match existing trim boards:

1. Are there many resistors on the existing board? If so, what is the value of the ones most prevalent on the board. These are almost always the isolation resistors. If you can't read the value, guess 2.5K $\Omega$ .
2. Are there any adjustment potentiometers for individual cells? Are there any adjustment potentiometers for sections? Are there both? If there is only a single set of potentiometers, then use the value of the isolation resistors. Guess 2.5K $\Omega$  if you aren't sure. If there are both individual and section trimpots, then choose the double isolation examples shown Section 7.0.
3. If you can't find any isolation resistors, set up the board to disable trimming. Read on to tell if the trim you have selected is correct. Disable any unused channels.
4. If the junction box you are replacing has an expansion port, use any unused cell (disable trim on it first) as the expansion output.

In any case, power up the system and see if the indicator appears to work. If you get stable numbers, you are on the right track.

If you are using signal trimming, you can tell if the isolation resistors match by the output of the cells. Put a weight on cells connected to the existing box and record the value. Put the same weight on a cell connected to the JB1010. If the reading is nearly the same, then the isolation resistor setting is probably correct. If the weight from the JB1010 is much too high, then the isolation resistors you have chosen are too low for the rest of the system or the system may have two layers of isolation resistors. If the weight from the JB1010 is much too low, then the isolation resistors you have chosen are too high for the rest of the system. You must match the isolation resistors as closely as possible so that the cell outputs are nearly the same. Once this matching is done, then trim the total system like any other scale.

# 9.0 Schematic Drawing of Connector Section (Two Load Cells)

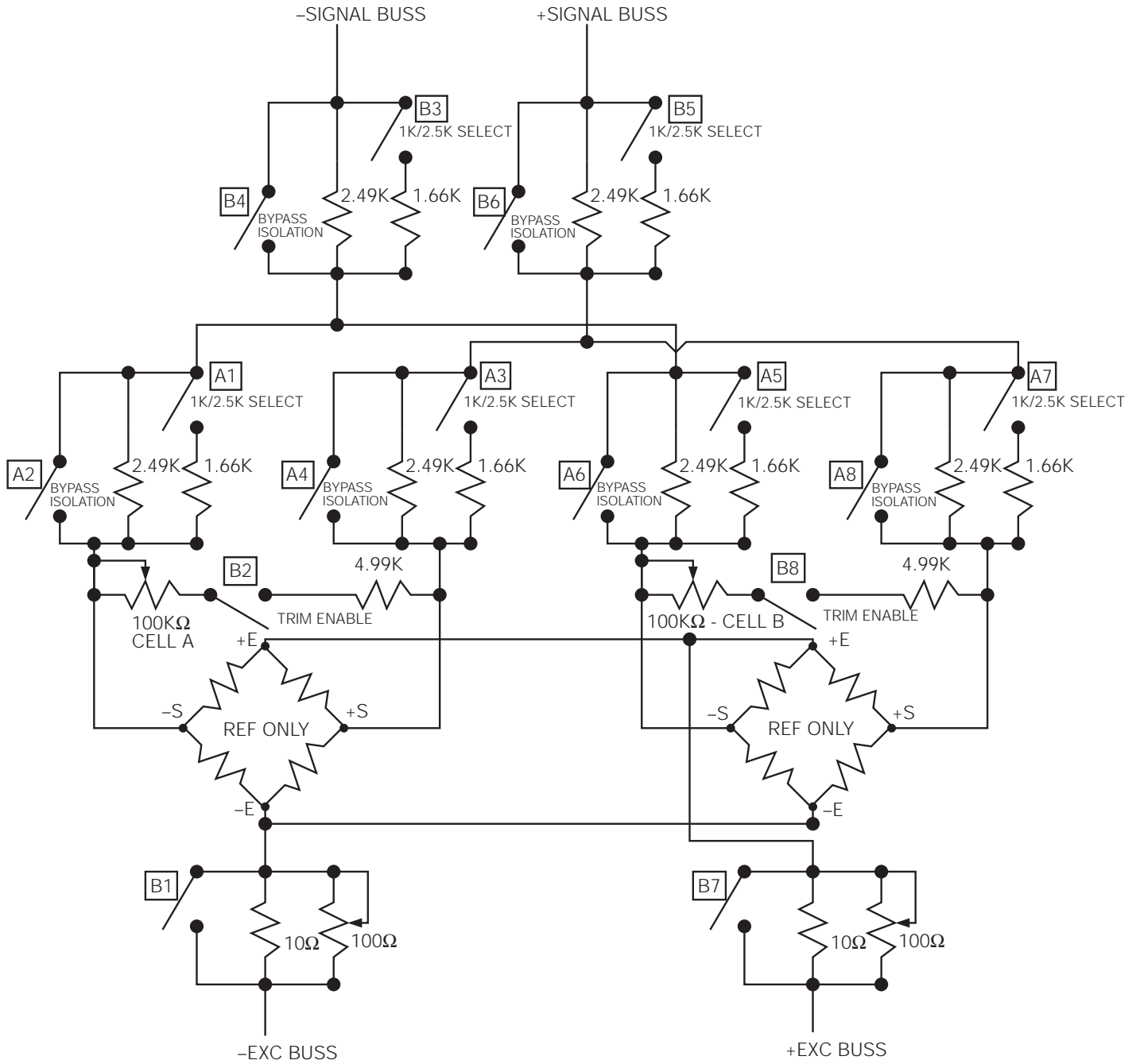





230 W. Coleman St. • Rice Lake, WI 54868 • USA  
U.S. 800-472-6703 • Canada/Mexico 800-321-6703  
International 715-234-9171

**[www.ricelake.com](http://www.ricelake.com)**  
**[mobile: m.ricelake.com](http://m.ricelake.com)**

© 2011 Rice Lake Weighing Systems

PN 36329 11/2011