

LaserLight2[®] Series

4-inch, 6-inch and Stop/Go Remote Displays

Version 3

Technical Manual



© Rice Lake Weighing Systems. All rights reserved.

Rice Lake Weighing Systems® is a registered trademark of
Rice Lake Weighing Systems.

All other brand or product names within this publication are trademarks or
registered trademarks of their respective companies.

All information contained within this publication is, to the best of our knowledge, complete and
accurate at the time of publication. Rice Lake Weighing Systems reserves the right to make
changes to the technology, features, specifications and design of the equipment without notice.

The most current version of this publication, software, firmware and all other product
updates can be found on our website:

www.ricelake.com

Revision History

This section tracks and describes manual revisions for awareness of major updates.

| Revision | Date | Description |
|----------|------------------|---|
| H | January 29, 2025 | Established revision history; updated non-UL power supply info and warning/note icons |
| | | |
| | | |

Table i. Revision Letter History



Technical training seminars are available through Rice Lake Weighing Systems. Course descriptions and dates can be viewed at www.ricelake.com/training or obtained by calling 715-234-9171 and asking for the training department.

Contents

| | | |
|------------|--|-----------|
| 1.0 | Introduction | 7 |
| 1.1 | Safety | 7 |
| 1.2 | Overview | 8 |
| 1.2.1 | Standard Features | 8 |
| 1.2.2 | Optional Features | 8 |
| 1.3 | Keypad | 9 |
| 1.4 | Annunciators | 10 |
| 2.0 | Installation and Setup | 11 |
| 2.1 | Unpacking | 11 |
| 2.2 | Wall Mounting | 11 |
| 2.2.1 | Flange Mounting Brackets | 11 |
| 2.2.2 | VESA Mounting Bracket | 12 |
| 2.3 | Wiring | 12 |
| 2.3.1 | AC Wiring | 13 |
| 2.3.2 | Serial Wiring | 15 |
| 2.3.3 | RF interference | 16 |
| 2.4 | Battery Replacement | 17 |
| 2.5 | LaserLight2 CPU Board (PN 169279) | 17 |
| 2.5.1 | 20 mA Current Loop | 18 |
| 2.5.2 | RS-232 | 18 |
| 2.5.3 | RS-422 | 18 |
| 2.5.4 | Reset Switch | 18 |
| 2.5.5 | Communicating with Indicators and LEDs | 18 |
| 2.5.6 | Ambient Light Sensor (PN 177369) | 18 |
| 2.5.7 | Decimal Point | 19 |
| 2.6 | Parts Kit, PN 92056 – All Models | 19 |
| 2.7 | Replacement Parts | 20 |
| 3.0 | Configuration | 25 |
| 3.1 | Auto-Learn | 25 |
| 3.2 | Catch-All Mode | 27 |
| 3.3 | Setting Time and Date | 27 |
| 3.4 | Manual Configuration | 28 |
| 3.4.1 | When External Keypad is Disabled | 28 |
| 3.4.2 | Menu Navigation Using Keypad | 29 |
| 3.5 | Serial Communications | 32 |
| 3.6 | Testing the Remote Display | 35 |
| 3.6.1 | Display | 35 |
| 3.6.2 | Digital Outputs | 36 |
| 3.6.3 | Digital Inputs | 36 |
| 3.6.4 | Loop-back | 36 |
| 3.7 | Version | 36 |
| 3.8 | Demand Print Displaying | 37 |
| 3.9 | Serial Commands | 37 |
| 3.9.1 | Remote Display Command Format | 38 |
| 3.9.2 | Set or Get the Digital I/O | 39 |
| 3.10 | Updating the LaserLight2 Firmware | 40 |



Rice Lake continually offers web-based video training on a growing selection of product-related topics at no cost. Visit www.ricelake.com/webinars

4.0 Options 41

4.1 Fiber-Optic Interface 41

4.2 Radio Interface 41

4.3 Visor Installation Kit 41

4.4 Pole Mount Kit 42

4.5 Offset Plate 44

5.0 Maintenance 45

5.1 Error Messages 45

5.2 Enclosure Dimensions 45

6.0 Specifications 46



Technical training seminars are available through Rice Lake Weighing Systems. Course descriptions and dates can be viewed at www.ricelake.com/training or obtained by calling 715-234-9171 and asking for the training department.



Rice Lake continually offers web-based video training on a growing selection of product-related topics at no cost. Visit www.ricelake.com/webinars

1.0 Introduction

This manual is intended for use by service technicians responsible for installing and servicing the LaserLight2 LED remote display.

 **IMPORTANT:** Information contained within this manual is exclusively for units with CPU board, PN 169279 (blue in color). LaserLight2 Technical Manual revision B or earlier contains information based on software Version 2 with CPU board, PN 166274 (green in color).

 Manuals and additional resources are available from the Rice Lake Weighing Systems website at www.ricelake.com. Warranty information can be found on the website at www.ricelake.com/warranties

1.1 Safety

Safety Definitions:

 **DANGER:** Indicates an imminently hazardous situation that, if not avoided, will result in death or serious injury. Includes hazards that are exposed when guards are removed.

 **WARNING:** Indicates a potentially hazardous situation that, if not avoided, could result in serious injury or death. Includes hazards that are exposed when guards are removed.

 **CAUTION:** Indicates a potentially hazardous situation that, if not avoided, could result in minor or moderate injury.

 **IMPORTANT:** Indicates information about procedures that, if not observed, could result in damage to equipment or corruption to and loss of data.

General Safety

 Do not operate or work on this equipment unless this manual has been read and all instructions are understood. Failure to follow the instructions or heed the warnings could result in injury or death. Contact any Rice Lake Weighing Systems dealer for replacement manuals.

 **WARNING**

Failure to heed could result in serious injury or death.

Some procedures described in this manual require work inside the indicator enclosure. These procedures are to be performed by qualified service personnel only.

Do not allow minors (children) or inexperienced persons to operate the LaserLight2.

Do not place fingers into slots or possible pinch points.

Do not use any load-bearing component that is worn beyond 5% of the original dimension.

Do not use this product if any of the components are cracked.

Do not exceed the rated load limit of the unit.

Do not make alterations or modifications to the unit.

Do not remove or obscure warning label (Figure 1-1).

Before opening the unit, ensure the power cord is disconnected from the outlet.

 **IMPORTANT:** Test the operation of the ground fault circuit interrupter each time the sign is plugged in (UL version only). To test the GFCI, plug in the LaserLight2 and press the TEST button. The LaserLight2 immediately powers off. If it does not, either the GFCI is mis-wired, there is a wiring problem in the same circuit, or the GFCI has malfunctioned and must be replaced. Press the RESET button to restore power to the LaserLight2 or the circuit.



Figure 1-1. Safety Label PN 16861

1.2 Overview

The LaserLight2 remote display features an ultra-bright LED display with a non-glare filtered lens for use in a wide variety of applications. The LaserLight2 Series is available with a 6-digit display. It is designed to work with most digital weight indicators, host computers, and peripherals using 20 mA current loop, RS-232 or RS-422 full and half duplex communications.

The unique IntelliBright™ feature uses a photo sensor to read ambient light and automatically adjusts the LaserLight2 display between day and night settings.

The LaserLight2 enclosure provides easy access to internal components. The front panel swings open for convenient setup and service. The enclosure has an external keypad which makes navigating configuration options convenient using the arrows, **Enter**, **Setup**, **Mode**, **Set**, and **Learn** keys.

1.2.1 Standard Features

The LaserLight2 display is available in 4" or 6" digit size. The LaserLight 4-SG display is a 4" digit size housed in the larger enclosure (13" x 31"), with a 6" Stop/Go light. Both styles use an **Auto-Learn** function which automatically determines the data format used by the attached indicator.

Additional standard features include:

- Six high-intensity red digits (double-row discrete LED)
- Auto learn mode of communication protocols
- Hold displayed weight (demand input)
- Software selectable standstill mode for no updates while in motion
- Durable weather tight IP66 enclosure
- Adjustable day/night intensity
- Software selectable time and date when the displayed weight is at zero and below
- Non-glare contrast filtered lens
- Mirror (reverse image) feature
- RS-232, 20 mA, and RS-422 communications
- Auto sensing 115/230 VAC power supply
- PEMs for VESA flat-wall mount or side-mounting flange
- Polyethylene breather vent inhibits internal moisture buildup
- Red, green, and arrow lights in Stop/Go version

1.2.2 Optional Features

Optional features of the LaserLight2 remote display include:

- Pole mount kit
- ConnexLink radio interface
- Visor kit
- VESA flat wall mount kit
- Offset kit (used with pole mount)

1.3 Keypad

The keypad, located on the bottom of the unit, allows for easy setup of the remote control.



Figure 1-2. LaserLight2 Keypad

| Key | Description |
|-----|---|
| | Used to navigate the configuration menu choices while in setup mode; The UP arrow exits the setup mode; The arrow keys can also be used to set time and date after the SET key has been pressed |
| | Used to select a setting |
| | Used to enter the setup mode |
| | Used to increment a value for time and date after the SET key has been pressed; The time and date value can be entered with the navigation keys |
| | Used to set time and date; press SET to toggle to the next value of the time or date format; Press SET one final time to exit the time and date setup |
| | Used to manually learn the incoming format; Use the navigation keys to move the displayed value to the correct position (Section 3.1 on page 25) |

Table 1-1. Key Functions

1.4 Annunciators

The LaserLight2 remote display uses a set of four high-intensity LED annunciators to provide additional information about the value displayed. The serial default values for the annunciators are **G & N** and **L & K**. Parameters for alternative values can be set under the serial menu, port 0.

The Stop/Go version of the LaserLight2 also has arrow and round light annunciators to indicate the different states of the digital outputs.



Figure 1-3. Front Panel Display (Stop/Go Model)

| LED | Description |
|-----|---|
| GR | Gross – Indicates the displayed weight is gross weight |
| NT | Net – Indicates the displayed weight is net weight |
| lb | Pounds – Indicates units associated with the displayed value, represents primary and secondary units |
| kg | Kilograms – Indicates units associated with the displayed value, represents primary and secondary units |
| -- | Red stop light, green go light, and green arrow – Indicates the traffic light state on the display; This feature applies to only the LaserLight 4-SG (Section 3.9 on page 37) |

Table 1-2. Annunciators

2.0 Installation and Setup

This section provides an overview of LaserLight2 Series installation, AC wiring, RS-232, RS-422, and 20 mA current loop connections. See [Section 3.0 on page 25](#) for information on configuring the remote display.



WARNING: The LaserLight2 has no on/off switch. Before opening the unit, ensure the power cord is disconnected from the power outlet.

Use a wrist strap for grounding to protect components from electrostatic discharge (ESD) when working inside the enclosure.

2.1 Unpacking

Immediately after unpacking, visually inspect the LaserLight2 for damage. If parts were damaged in shipment, notify Rice Lake Weighing Systems and the shipper immediately.

The shipping carton contains the LaserLight2 as well as the following components:

- Weathertight, IP66 rated enclosure with a blue CPU board and either mounting flanges or a VESA mount
- Installation manual



IMPORTANT: Remove the protective plastic on the lens of the LaserLight2 as the protective plastic obscures the display and over time becomes difficult to remove.

2.2 Wall Mounting

The LaserLight2 remote display can be mounted to a vertical surface or pole using 1/4" hardware or a VESA mounting bracket for increased versatility.

2.2.1 Flange Mounting Brackets

The flange tab mounting comes in both 4" or 6" brackets.

Select a site and secure the remote display to a wall using included hardware and the mounting holes on the flange tabs.

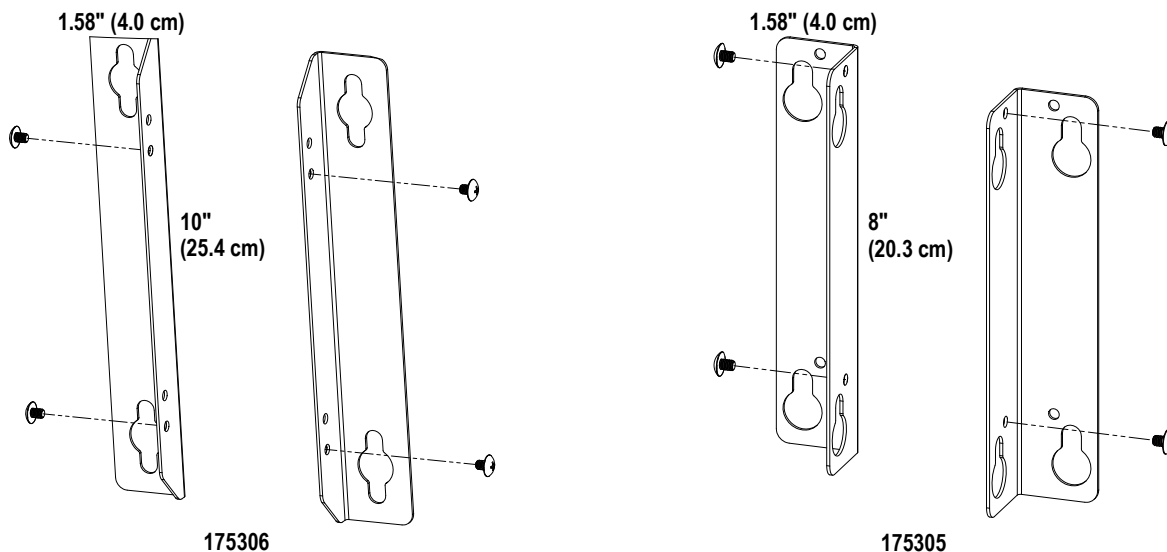

Figure 2-1. Side Mount Flange Brackets for 6" and 4" Models

An optional pole mounting kit is required when installing the remote display on a pole. The optional pole mounting kit fits 4" - 6" poles ([Section 4.4 on page 42](#)).

2.2.2 VESA Mounting Bracket

The VESA mount allows for a wide variety of mounting options to be compatible with the LaserLight2.

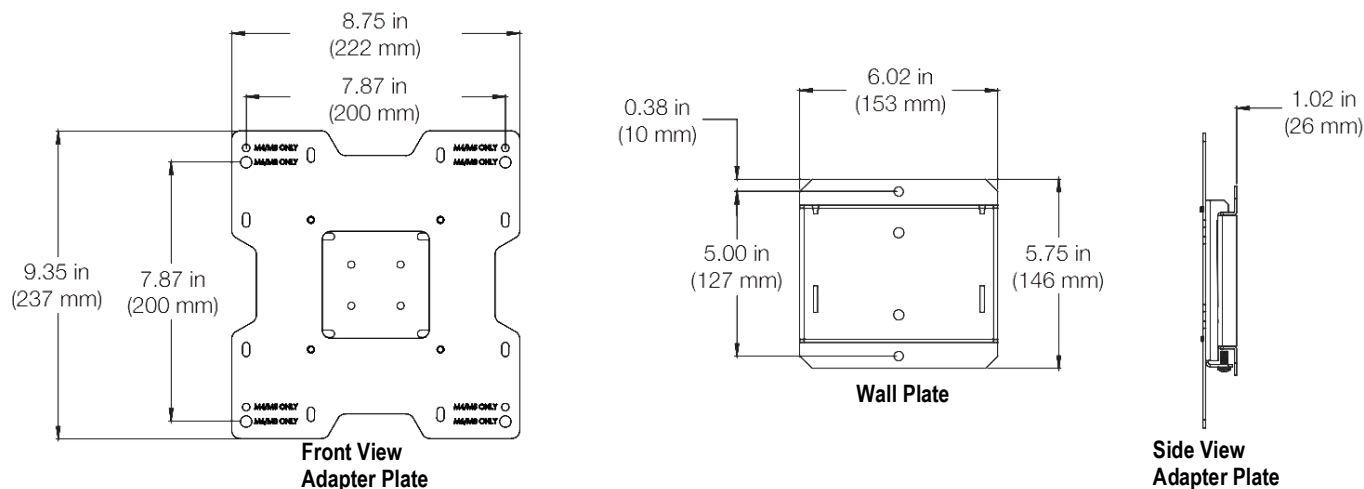

Figure 2-2. VESA Mounting Bracket

The four mounting PEMs on the LaserLight2 are threaded, see [Figure 2-13 on page 24](#) and [Table 2-11 on page 24](#) for applicable mounting bracket part numbers.

2.3 Wiring

The LaserLight2 remote display provides three cord grips located on the underside of the enclosure; one for the supplied A/C power cord and two for serial communications. The LaserLight2 remote display comes pre-wired. Ribbon cables connect the CPU board to the digit display boards. Only the serial communications cable must be connected.



WARNING: The LaserLight2 remote display has no on/off switch. Before opening the unit, ensure the power cord is disconnected from the power outlet.

To open and wire the remote display in [Section 2.3.1 on page 13](#):

1. If the remote display is not open, loosen the captive screws located on the front of the remote display enclosure.
2. Pull the hinged display outward to open the enclosure.
3. Once the appropriate wiring is complete, close the hinged display and tighten to 16-20 in-lb.

2.3.1 AC Wiring

The LaserLight2 power supply can run on either 115 or 230 VAC. The AC wiring is run through the cord grip to a 3-position AC terminal block bracket located on the inside of the enclosure.

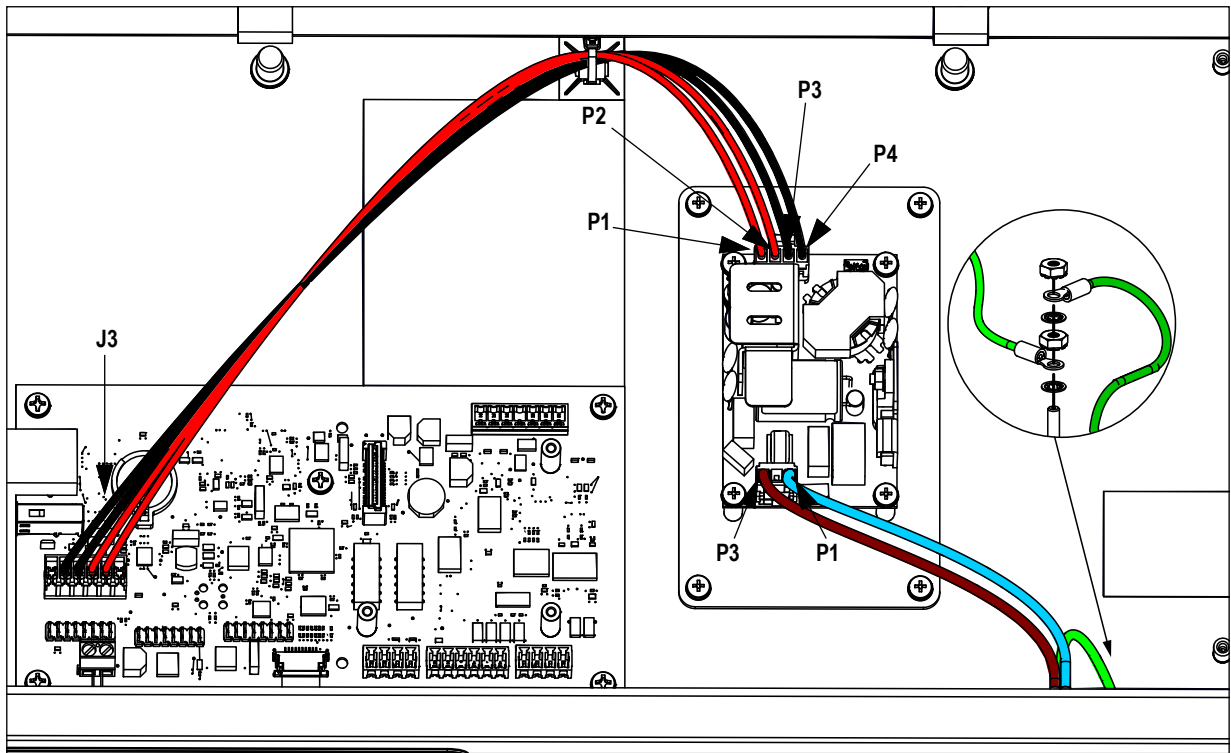

Figure 2-3. Power Supply Location and Wiring (non-UL Version Model)

Refer to [Table 2-1](#) and [Table 2-2](#) for wiring connections in the non-UL Version Model.

| AC Input from Power Cord | | |
|--------------------------|-------------|-----------------------|
| Pin | Wire | Color |
| 1 | Neutral (N) | Blue or White |
| To Ground Stud | Ground (⊕) | Green or Green/Yellow |
| 3 | Live (L) | Brown or Black |

Table 2-1. AC Input Wiring Connections

| DC Output to J3 | | |
|-----------------|-------------------------|-------|
| Pin | Wire | Color |
| 1 | Positive DC Output (+V) | Red |
| 2 | Positive DC Output (+V) | Red |
| 3 | Negative DC Output (-V) | Black |
| 4 | Negative DC Output (-V) | Black |

Table 2-2. DC Output Wiring Connections

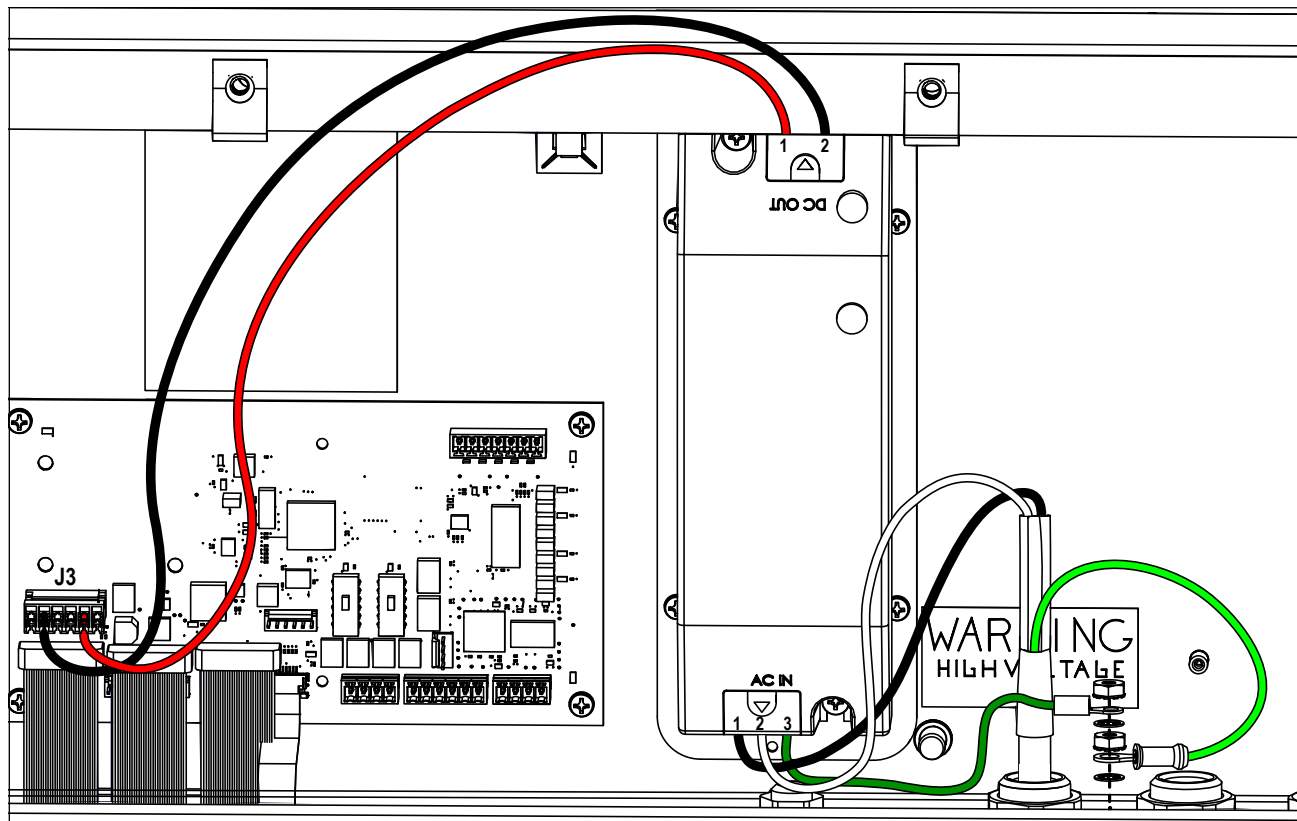

Figure 2-4. Power Supply Location and Wiring (UL Version Model)

Refer to [Table 2-3](#) and [Table 2-4](#) for wiring connections in the UL Version Model.

| AC Input from Power Cord | | |
|--------------------------|-------------|-----------------------|
| Pin | Wire | Color |
| 1 | Live (L) | Brown or Black |
| 2 | Neutral (N) | Blue or White |
| 3 | Ground (⊕) | Green or Green/Yellow |

Table 2-3. AC Input Wiring Connections

| DC Output to J3 | | |
|-----------------|-------------------------|-------|
| Pin | Wire | Color |
| 1 | Positive DC Output (+V) | Red |
| 2 | Negative DC Output (-V) | Black |

Table 2-4. DC Output Wiring Connections

2.3.2 Serial Wiring

Serial communications are connected to the CPU board using removable screw terminal plugs on J6, J8 and J9 ([Figure 2-6 on page 17](#)).

To connect the communications cable to remote display:

1. Disconnect power then open the remote display by removing the captive screws on the front of the enclosure and swinging the hinged front cover forward.
2. Loosen the serial cable cord grip and push enough of the communications cable into the enclosure to allow for attachment to the CPU board.
3. Strip 1/4" (0.65 cm) of insulation from the serial cable ends.
4. Make cable connections for RS-232, RS-422, or 20 mA current loop communications as described in [Table 2-5 on page 16](#).
5. Remove excess cable from inside the enclosure. Tighten the serial cable cord grip.
6. Close the hinged front cover and tighten to 16-20 in/lb.

2.3.3 RF interference

An EMI filter can be installed on the serial interface cable to eliminate RF interference.

1. Run the serial wires through the EMI filter provided in the parts kit ([Table 2-6 on page 19](#)).
2. Loop the serial wires around the EMI filter.
3. Use the provided plastic cable tie to secure the looped wires to the ferrite and the serial cable; this prevents the ferrite from coming in contact with the CPU board.



Figure 2-5. Cylindrical Ferrite Placement for RF Interference

| CPU Board Connector | Pin Assignment | Function | CPU Board Silk Naming | Port Position |
|-------------------------|----------------|------------------|-----------------------|---------------|
| J1 Digital Input/Output | 1 | Ground | GROUND | – |
| | 2 | Digital Input 0 | DIGIN 0 | – |
| | 3 | Digital Input 1 | DIGIN 1 | – |
| | 4 | +5 V | +5 C | – |
| | 5 | Digital Output 0 | DIGOUT0 CTRL | – |
| | 6 | Digital Output 1 | DIGOUT1 CTRL | – |
| | 7 | Ground | GROUND | – |
| J6 20 mA | 1 | Tx- | MATX- | Port 0 |
| | 2 | Tx+ | MATX+ | Port 0 |
| | 3 | Rx- | MARX- | Port 0 |
| | 4 | Rx+ | MARX+ | Port 0 |
| J8 RS-232 | 1 | SIG GND | GNDIS01 | Port 0/1 |
| | 2 | SIG GND | GNDIS01 | Port 0/1 |
| | 3 | RxD 1 | RIN2 | Port 1 |
| | 4 | RxD 0 | RIN1 | Port 0 |
| | 5 | TxD 1 | TOUT2 | Port 1 |
| | 6 | TxD 0 | TOUT1 | Port 0 |
| J9 RS-422 | 1 | Tx- (Z) | RS485-Z | Port 0 |
| | 2 | Tx+ (Y) | RS485-Y | Port 0 |
| | 3 | Rx- (B) | RS485-B | Port 0 |
| | 4 | Rx+ (A) | RS485-A | Port 0 |

Table 2-5. Serial Communications Wiring



NOTE: Terminals J1, J6, J8, and J9 are removable screw terminal plugs.

Port 0 is used for input only and port 1 is used to drive additional LaserLight2 Remote Displays ([Table 2-5](#)).

2.4 Battery Replacement

The lithium battery (PN 69291) on the CPU board maintains the real-time clock.

To replace the battery:

1. Ensure unit is unplugged from power source.
2. Open unit and place the tip of a finger in the notched area near the battery retaining spring and slide the battery out of position on the CPU board.
3. Replace with new battery. Ensure the positive side is up and slide the battery under the retaining ring then close the unit.



WARNING: Risk of explosion if battery is replaced by an incorrect type. Dispose of used batteries according to state and local regulations.

2.5 LaserLight2 CPU Board (PN 169279)

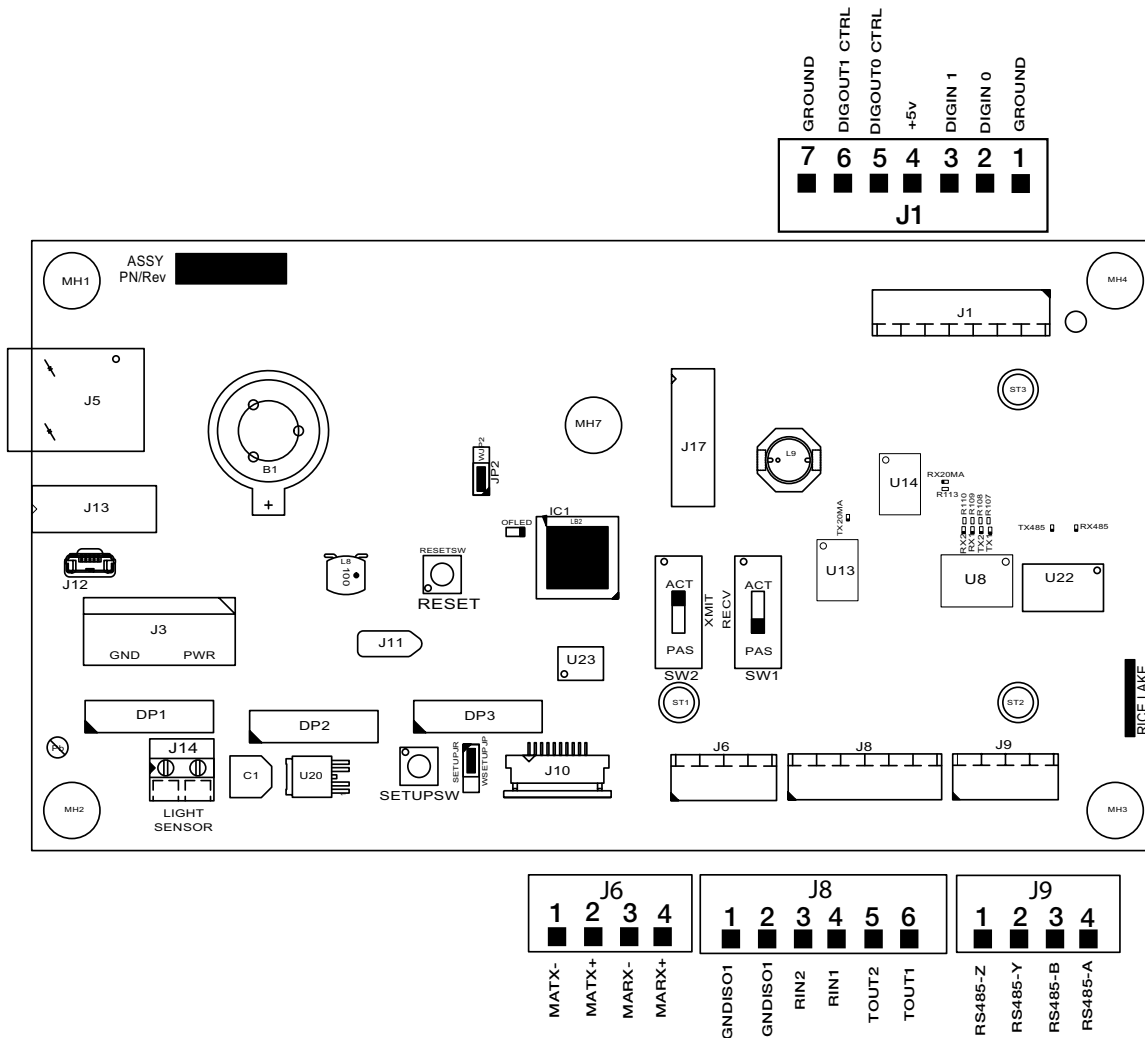

Figure 2-6. LaserLight2 Remote Display CPU Board

Port 0, which is connected to the indicator, supports three configurations; 20 mA, RS-232, and RS-422 communications.

Port 1, which is the Echo port, does not support 20 mA but does support RS-232 communications.

2.5.1 20 mA Current Loop

The 20 mA current loop communication is provided on connector J6 of the CPU board (Figure 2-6 on page 17 and Table 2-5 on page 16).

Make sure to select active or passive switch settings.

2.5.2 RS-232

The RS-232 connection is provided on connector J8 of the CPU board (Figure 2-6 on page 17 and Table 2-5 on page 16).

2.5.3 RS-422

The RS-422 connection is provided on connector J9 of the CPU board (Figure 2-6 on page 17 and Table 2-5 on page 16).

2.5.4 Reset Switch

The reset switch enables a simulated power up reset, eliminating the need to unplug the unit to perform a reset. The unit then goes back to normal operation mode, see Figure 2-6 on page 17 for the reset switch location on the CPU board.

2.5.5 Communicating with Indicators and LEDs

There are eight small LEDs for RS-232, RS-422, and 20 mA located on the CPU board (above U8 on the CPU board in Figure 2-6 on page 17) which flash when serial data is received or sent. The transmit indicators flash when data is sent out of the port, while the receive indicator flashes when data is received. A steady indicator on a receive LED reflects a connection with no streaming data.

2.5.6 Ambient Light Sensor (PN 177369)

Ambient light sensors are used to detect light or brightness in a manner similar to the human eye. The ambient light sensor is connected to J14 on the CPU board and adjusts the brightness on the LaserLight2 in daytime or nighttime conditions.

A third setting (DYLVL) is the ambient brightness threshold, at which the display changes from night to day mode and vice versa. Settings range between 1 and 10 with 1 requiring less intense light to change to day mode and 10 requiring more intense light to change from night to day mode.



NOTE: The LaserLight2 defaults to the Night setting if the sensor is absent.

Do not cut the light sensor pins to the same length, as the long pin is used to identify orientation.

To install a light sensor, ensure the pins (long and short) are inserted correctly into the J14 connector. The short pin side has a flat side to the sensor and must be oriented on the right side of J14.

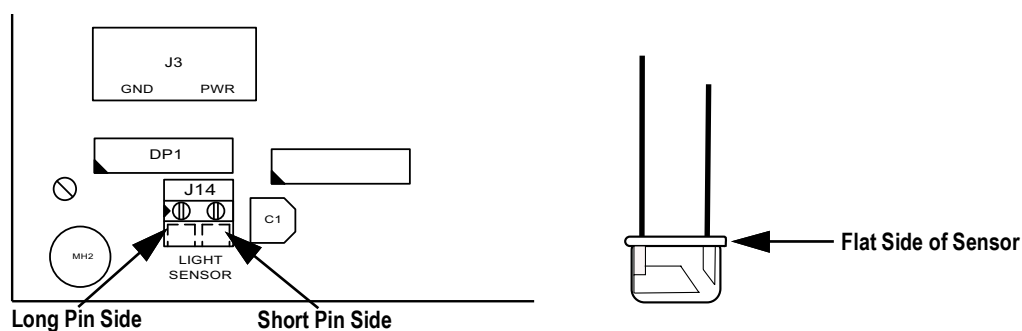

Figure 2-7. Light Sensor Pin Orientation

Insert into the terminal block and bend pins slightly to ensure the pins are located by the hole in the bottom of the enclosure.

2.5.7 Decimal Point

Ensure the decimal point configuration is compatible with the remote display when configuring the indicator attached to the LaserLight2. The primary display board has decimal LED's. These can be changed to commas by moving jumpers JMP1 and JMP2 (located on the back of the display board) to the right.

Ensure the decimal point/comma jumper is in the proper position on the display board.

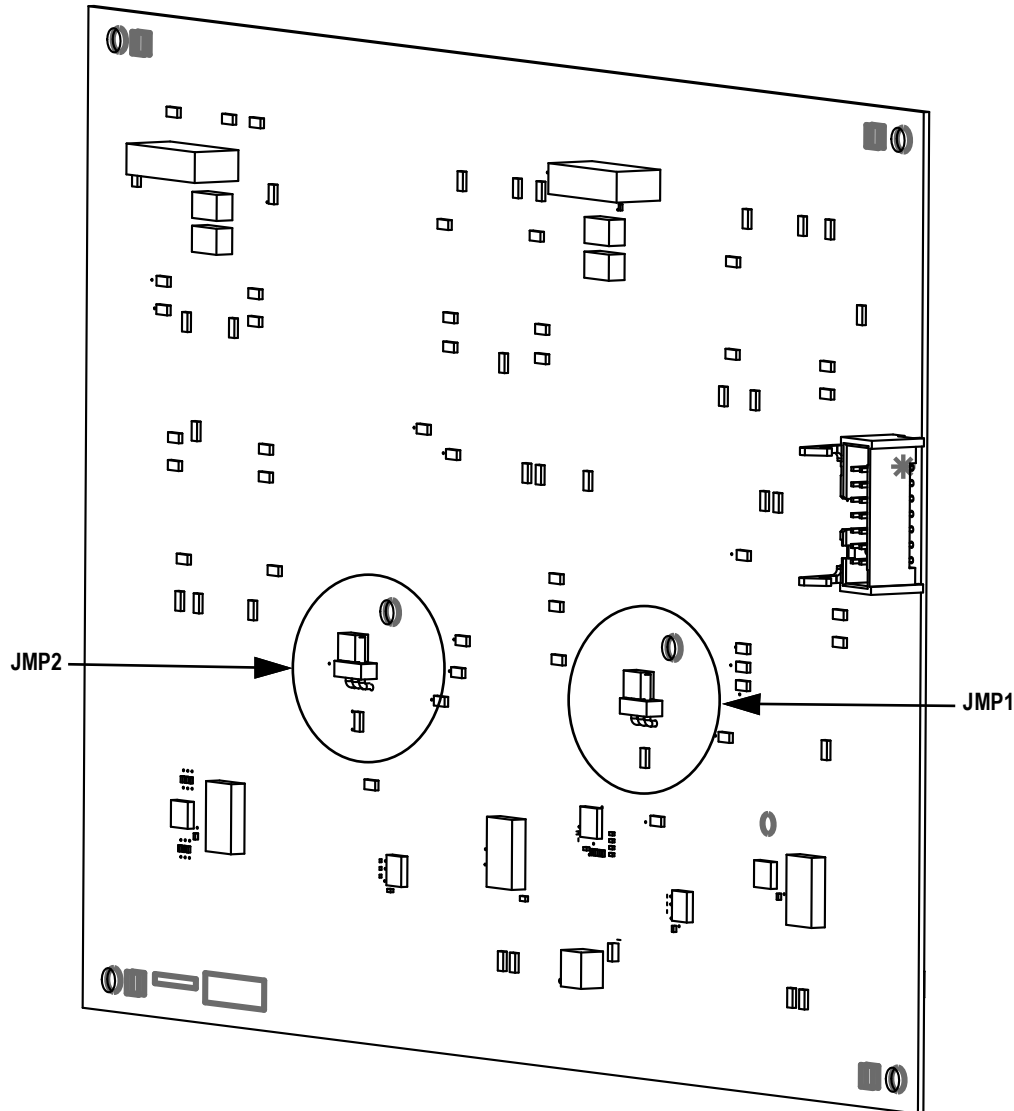

Figure 2-8. Display Board Jumper Location

2.6 Parts Kit, PN 92056 – All Models

See [Table 2-6](#) for the common LaserLight2 parts kit.

| Part No. | Description | Qty. |
|----------|---------------------------------|------|
| 15631 | Cable Tie, 3" Nylon | 2 |
| 66730 | Filter, Cylindrical EMI | 1 |
| 76513 | Conn, 4 Position Screw Terminal | 2 |
| 76514 | Conn, 6 Position Screw Terminal | 1 |

Table 2-6. LaserLight2 Parts Kit

2.7 Replacement Parts

See the following information for the LaserLight2 parts illustration and parts kit:

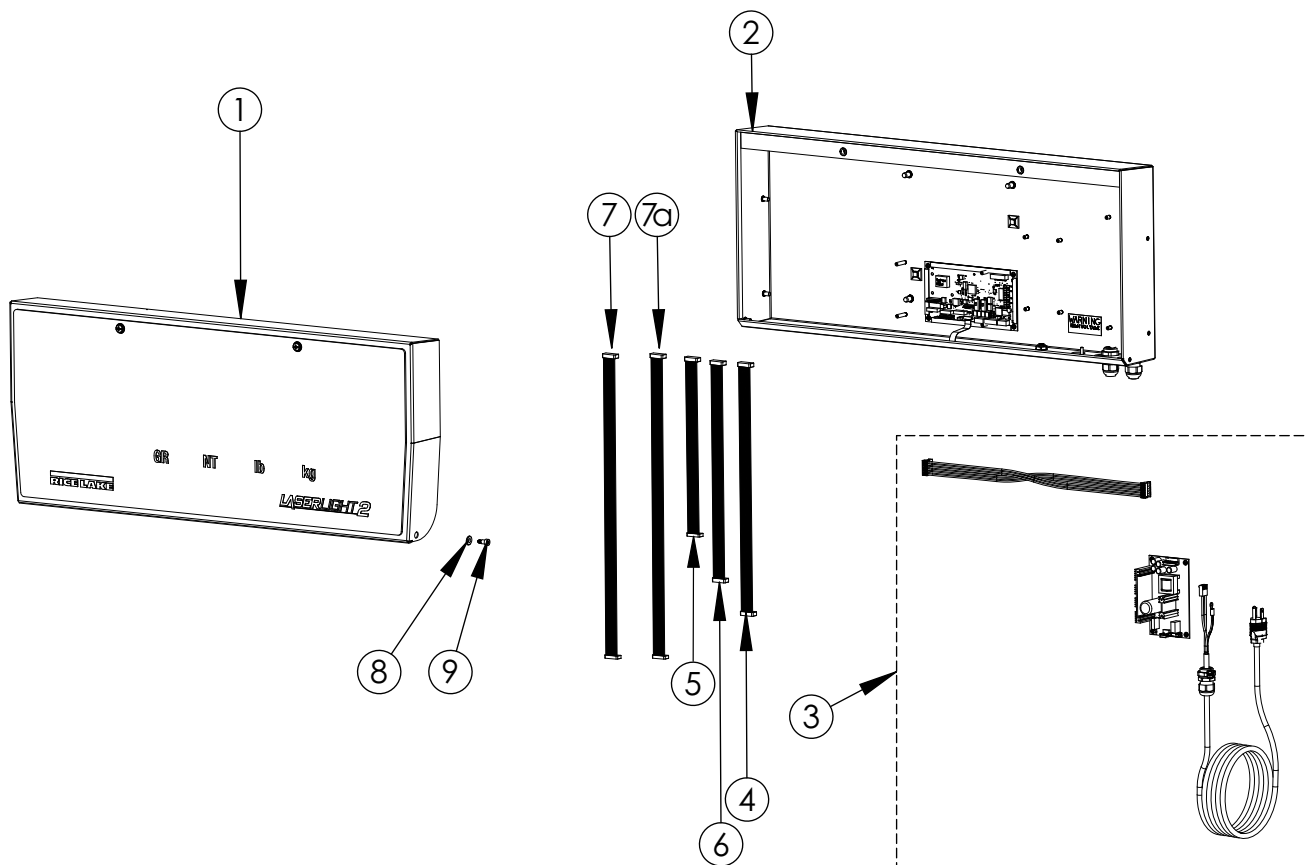

Figure 2-9. LaserLight2 Parts Illustration

| Item No. | Part No. | Description | 4" Model | 6" Model | 4" Stop/Go Model | Qty. |
|----------|----------|---|----------|----------|------------------|------|
| 1 | 173599 | Front Panel Assembly (Figure 2-11 on page 22) | - | - | - | 1 |
| 2 | 173146 | Cabinet Assembly (Figure 2-10 on page 21) | - | - | - | 1 |
| 3 | 174488 | Power Kit (Figure 2-11 on page 22) | - | - | - | 1 |
| 4 | 169391 | Cable, Ribbon 16" long | - | - | x | 2 |
| 5 | 76224 | Cable, Ribbon 8" | - | x | - | 2 |
| 6 | 76225 | Cable, Ribbon 14" | x | x | - | 2 |
| 7 | 104284 | Cable, Ribbon 23" Long | - | - | x | 1 |
| | 104283 | Cable, CPU to Traffic | - | - | x | 1 |
| 8 | 173144 | Washer, Black Nylon | x | x | x | 2 |
| 9 | 178043 | U-Nut, 1/4-20 Tapped Barrel Free Spin | x | x | x | 2 |

Table 2-7. LaserLight2 Parts

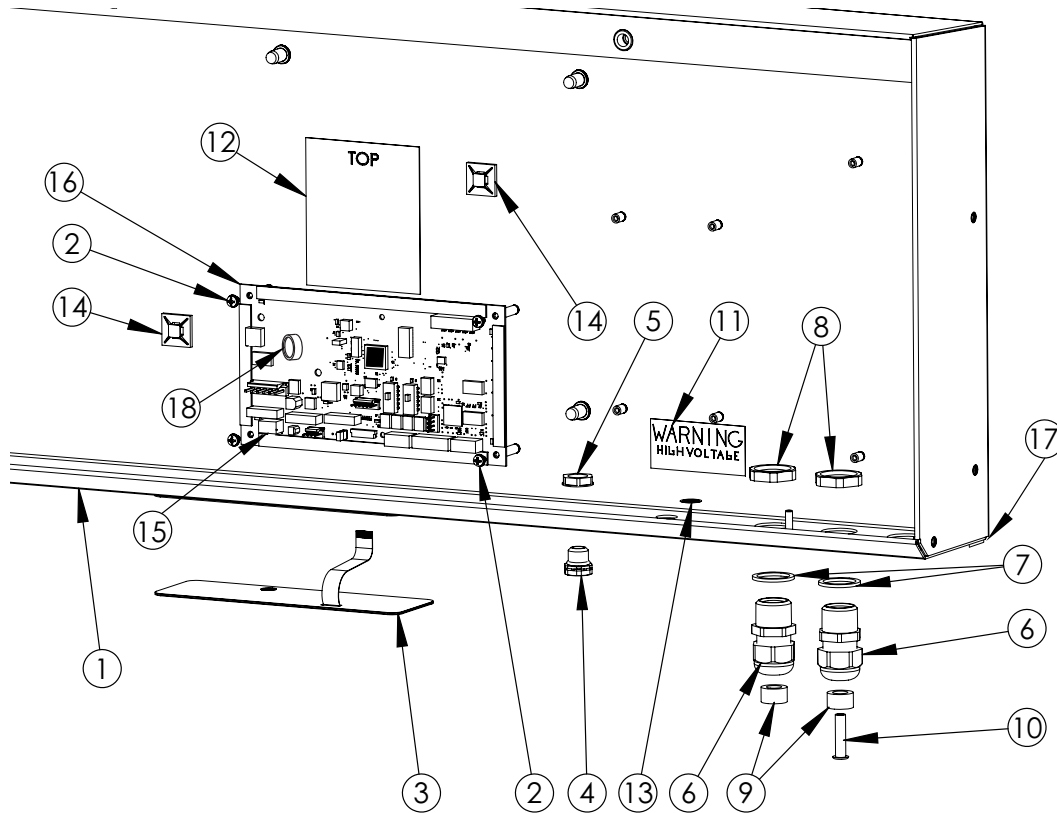

Figure 2-10. Cabinet Parts Illustration

| Item No. | Part No. | Description | 4" Model | 6" Model | 4" Stop/Go Model | Qty. |
|----------|----------|----------------------------------|----------|----------|------------------|------|
| - | 181411 | Cabinet | - | x | x | 1 |
| - | 173597 | Cabinet | x | - | - | 1 |
| 1 | 181411 | Rear Panel Assembly | - | x | x | 1 |
| | 181408 | Rear Panel Assembly | x | - | - | 1 |
| 2 | 14839 | Screw, Mach 6-32NC x 1/4 | x | x | x | 5 |
| 3 | 166345 | Overlay, LaserLight2 | x | x | x | 1 |
| 4 | 88733 | Vent, Breather Sealed | x | x | x | 1 |
| 5 | 88734 | Nut, Breather Vent | x | x | x | 1 |
| 6 | 15628 | Cord Grip, 1/2 NPT Black | x | x | x | 2 |
| 7 | 30376 | Seal Ring, Nylon 1/2 NPT | x | x | x | 2 |
| 8 | 15630 | Locknut, 1/2 NPT Black | x | x | x | 2 |
| 9 | 15665 | Gland, Reducing 1/2 NPT | x | x | x | 2 |
| 10 | 19538 | Post Plug, Slotted Black | x | x | x | 1 |
| 11 | 16861 | Label, Warning High | x | x | x | 1 |
| 12 | 177093 | Label, Serial Comm Pin Out | x | x | x | 1 |
| 13 | 16892 | Label, Ground Protective | x | x | x | 1 |
| 14 | 15650 | Mount, Cable Tie 3/4" | x | x | x | 2 |
| 15 | 177369 | Ambient Light Sensor | x | x | x | 1 |
| 16 | 178869 | Board, CPU - Blue Board | x | x | x | 1 |
| 17 | 26408 | Bumper, Self Adhesive 3/4 Rubber | x | x | x | 2 |
| 18 | 69291 | Battery, 3 V Coin Lithium | x | x | x | 1 |

Table 2-8. Cabinet Parts List

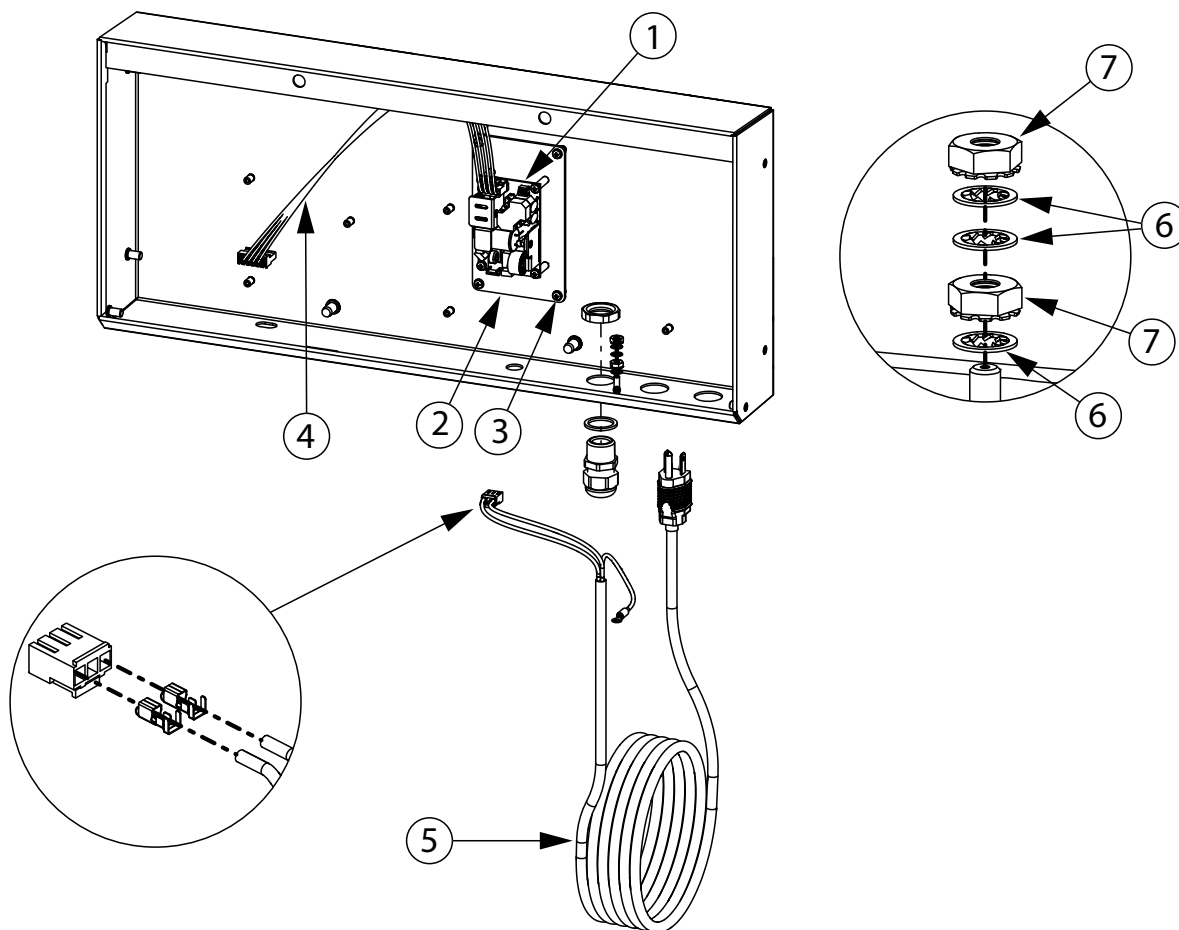

Figure 2-11. Power Kit Parts Illustration

| Item No. | Part No. | Description | Qty. |
|----------|----------|------------------------------|------|
| 1 | 208511 | Power Supply, 12 VDC | 1 |
| 2 | 214447 | Bracket Assembly Adaptor | 1 |
| 3 | 14839 | Screw, Mach 6-32NC x 1/4 | 8 |
| 4 | 214445 | Cable Assembly, Power Supply | 1 |
| 5 | 214444 | Power Cord Assembly Remote | 1 |
| 6 | 15134 | Washer, Lock No. 8 Type A | 3 |
| 7 | 14626 | Nut, Kep 8-32NC Hex | 2 |

Table 2-9. Power Kit Parts List

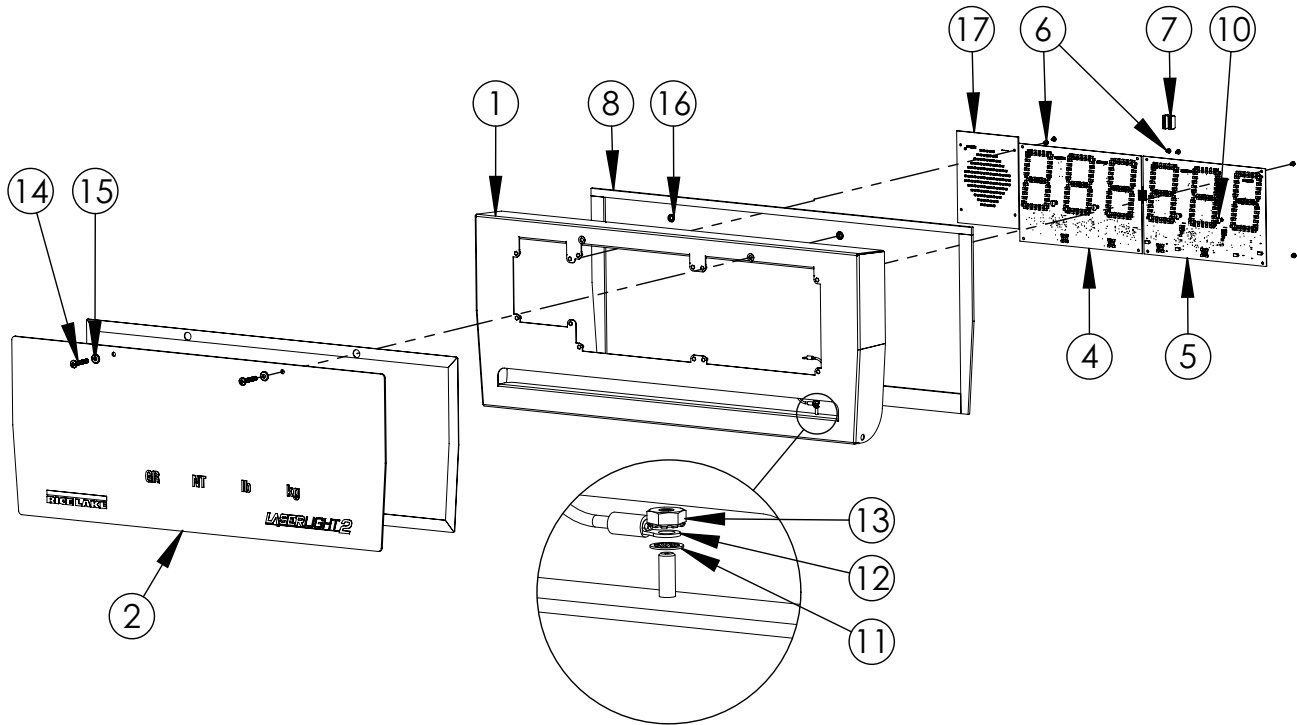

Figure 2-12. Front Panel Parts Illustrations

| Item No. | Part No. | Description | 4" Model | 6" Model | 4" Stop/Go Model | Qty. |
|----------|----------|-------------------------------|----------|----------|------------------|------|
| 1 | 181412 | Front Cabinet | - | - | x | 1 |
| | 181410 | Front Cabinet | - | x | - | 1 |
| | 181409 | Front Cabinet | x | - | - | 1 |
| 2 | 173824 | Lens, Display | - | - | x | 1 |
| | 169715 | Lens, Display | - | x | - | 1 |
| | 167134 | Lens, Display | x | - | - | 1 |
| 4 | 167401 | Board, Display Primary | x | - | x | 1 |
| | 168033 | Board, Display Primary | - | x | - | 1 |
| 5 | 167402 | Board, Display Secondary | x | - | x | 1 |
| | 168034 | Board, Display Secondary | - | x | - | 1 |
| 6 | 14839 | Screw, Mach 6-32NC x 1/4 | x | x | - | 8 |
| | | Screw, Mach 6-32NC x 1/4 | x | - | x | 12 |
| 7 | 76226 | Cable, Ribbon 5" Long | x | x | - | 1 |
| 8 | 170174 | Gasket | - | x | x | 1 |
| | 167238 | Gasket | x | - | - | 1 |
| 10 | 175212 | Standoff, Plastic Press-in | x | x | x | 4 |
| 11 | 15134 | Washer, Lock No. 8 Type A | x | x | x | 1 |
| 12 | 15601 | Ground Wire, 6" with No. 8 | x | x | x | 1 |
| 13 | 14626 | Nut, Kep 8-32NC Hex | x | x | x | 1 |
| 14 | 175781 | Machine Screw, 1/4-20 x 1-1/2 | x | x | x | 2 |
| 15 | 182246 | Fasteners, 1/4" | x | x | x | 1 |
| | 182281 | Washer Shell, 1/4" | x | x | x | 1 |
| 16 | 166653 | Retainer, Pushnut Bolt 1/4 | x | x | x | 2 |
| 17 | 103651 | Board Assembly, LED Traffic | - | - | x | 1 |

Table 2-10. Front Panel Parts List

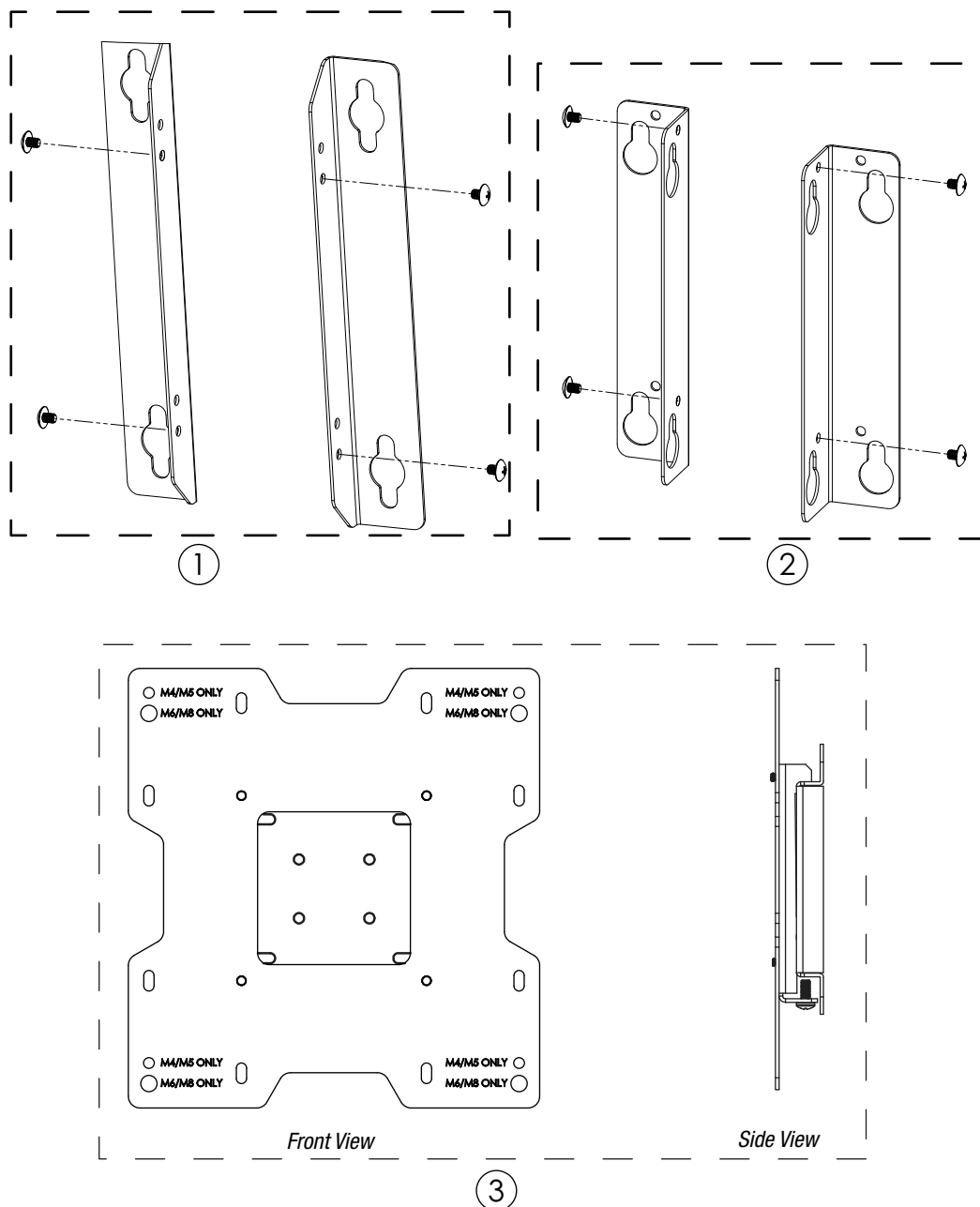

Figure 2-13. Mounting Options Parts Illustrations

| Item No. | Part No. | Description | 4" Model | 6" Model | 4" Stop/Go Model | Qty. |
|----------|----------|---------------------------|----------|----------|------------------|------|
| 1 | 175306 | Option Kit | - | x | x | 1 |
| | 154183 | Screw, Phillip Truss Head | - | | | 4 |
| | 183467 | Bracket, Right/Left Mount | - | | | 2 |
| 2 | 175305 | Option Kit | x | - | | 1 |
| | 154183 | Screw, Phillip Truss Head | | - | | 4 |
| | 183432 | Bracket, Right/Left Mount | | - | | 2 |
| 3 | 175213 | Vesa Mount, Low Profile | - | - | | 1 |

Table 2-11. Mounting Options Parts List

3.0 Configuration

This section provides an overview of LaserLight2 Series configuration instructions.

Configuration can be simplified or eliminated with the Auto-Learn feature.

3.1 Auto-Learn

Auto-Learn examines the serial data stream sent from the attached indicator and determines the data settings and format used by the indicator. Auto-Learn is capable of recognizing several common data formats used in the weighing industry.



NOTE: For Auto-Learn to work, the data must be sent using one of the supported baud rates in the exact format of one of the predefined stream data formats. If the format does not exactly match one of the predefined formats then the Catch All mode must be used (Section 3.2 on page 27).

Auto-Learn is enabled or disabled based on the setting of the Port 0 Lock parameter. If Port 0 Lock is OFF, the LaserLight2 attempts to learn the incoming data every time it is powered up and each time the data stream is paused and restarted. If Port 0 Lock is ON, no Auto-Learn takes place. By default, Port 0 Lock is set to OFF. If Auto-Learn does not start on its own, it can be initiated using the following steps.

1. Press . The LaserLight2 cycles through baud rates looking for the one being used. If it can identify the baud rate and read the format, it displays the weight. If it does not find a baud rate, it displays **LError** and reverts to using the last learned baud and stream data format.
2. Once the Auto-Learn sequence is correct, lock the Port 0 configuration menu to save the Auto-Learn settings (Figure 3-6 on page 32).



NOTE: If DSPERR displays after the Auto-Learn process then the value being sent is beyond the capabilities of the display.

Example: Too many digits, or too many digits including a minus sign.

Currently Supported Stream Data Formats as of Firmware Version 3.04:

| | |
|----------------------------|---|
| Rice Lake / Condec: | <STX><P><W7.><U><M><S><CR><LF> |
| | <STX> Start of text character (ASCII 2) |
| | <P> Space for positive, - for negative |
| | <W7.> 7-digit weight, floating decimal, leading spaces |
| | <U> Units, upper case: L or K |
| | <M> Mode, upper case: G or N |
| | <S> Status, upper case: <SP> =OK, M=Motion, O=Overload, Z=Zero, I=Invalid |
| | <CR><LF> Carriage return and line feed |
| Toledo: | <STX><A><C><W06><T06><CR> |
| | <STX> Start of text character (ASCII 2) |
| | <A><C> Status bytes (polarity, mode, decimal location, and others) |
| | <W06> 6-digit weight (gross or net), leading zeros, no decimal |
| | <T06> 6-digit tare, leading zeros, no decimal |
| | <CR> Carriage return and line feed |
| AWTX: | <T><M><P><W06.><SP><UU><CR><LF> |
| | <T> Tare register, space, or single digit number |
| | <M> Mode, upper case: G, T, or N |
| | <P> + for positive, - for negative |
| | <W06.> 6-digit weight, floating decimal, leading zeros |
| | <SP> Space (ASCII 32) |
| | <UU> 2-character units, lower case: lb or kg |
| | <CR><LF> Carriage return and line feed |

| | |
|--|---|
| Cardinal (SB-200): | <CR><P><W06.><S><SP><UU><SP><M><SP><SP><ETX> |
| <CR> | Carriage return |
| <P> | Space for positive, - for negative |
| <W06.> | 6-digit weight, leading zeros, always decimal |
| <S> | Status: Space=OK, m=motion, o=overload |
| <SP> | Space (ASCII 32) |
| <UU> | 2-character units, lower case: lb or kg |
| <M> | Mode, lower case: g or n |
| <ETX> | End-of-text character (ASCII 3) |
| Dini: | <SS>,<MM>,<P><W7.>,<UU><CR><LF> |
| <SS> | 2-character status: ST=stable, US=unstable, UL/OL=under/overload |
| <MM> | 2-character mode, upper case: GS=gross, NT=net |
| <P> | Space for positive, - for negative |
| <W7.> | 7-digit weight, floating decimal, leading spaces |
| <UU> | 2-character units, lower case – lb or kg |
| <CR><LF> | Carriage return and line feed |
| Hardy: | ><CR><LF><SP>GROSS<SP><-W7.><SP><UU><SP><CR><LF> |
| | <SP>NET<SP><SP><SP><-W7.><SP><UU><SP><CR><LF> |
| | <SP>TARE<SP><SP><-W7.><SP><UU><SP><CR><LF><CR><LF> |
| <-W7.> | 7-digit weight, floating decimal, - for negative in first position |
| <CR><LF> | Carriage return and line feed |
|  | NOTE: The full 65-character format must be used, but only the gross weight is displayed. For Hardy only, a stream of at least 5 full frames per second is required for Auto-Learn to work. |
| GSE: | <W-8.><SP><UUUUU><SP><MMMMM><CR><LF> |
| <W-8.> | 8-digit weight, floating decimal and negative sign |
| <SP> | Space (ASCII 32) |
| <UUUUU> | 5-character units, lower case: lb<SP><SP><SP> or kg<SP><SP><SP> |
| <MMMMM> | 5-character mode, upper case: GROSS, NET<SP><SP>, TARE<SP> |
| <CR><LF> | Carriage return and line feed |
| Fairbanks: | (20mA) <STX><SS><W-7.><ETX> |
| <STX> | Start of text character (ASCII 2) |
| <SS> | 2-digit type: 40=Gross lb, 41=Net lb, 42=Gross kg, 43=Net kg |
| <-W7.> | 7-digit weight, floating decimal and negative sign, leading spaces |
| <ETX> | End-of-text character (ASCII 3) |
| MSI: | <W-7.><SP><UU><SP><MM><CR><LF> |
| <W-7.> | 7-digit weight, floating decimal and negative sign |
| <SP> | Space (ASCII 32) |
| <UU> | 2-character units, upper case – LB or KG |
| <MM> | 2-character mode, upper case – GR or NT |
| <CR><LF> | Carriage return and line feed |



3.2 Catch-All Mode

The Catch-All mode attempts to identify only numeric data in the stream format. No unit or mode annunciators are identified. The display annunciators can be set manually with the parameter **SETANN** in the serial menu for Port 0 (Figure 3-6 on page 32).

- Manually configure the serial port settings then lock Port 0
- Set the special indicator type to 1 in the Port 0 menu
- The data stream must contain a standard end token character for data packets (<cr>, <lf> <ff>, <ETX> and others) as it only finds the last data number sent in the packet

Examples: Valid - 1234<cr>5678<cr> displays 1234 then 5678

Valid - 1234 5678<cr> displays only 5678

If the least significant digit of the displayed weight is not in the right most character position, the value can be shifted left or right using   to shift the display.

Example: 12345678<cr> displays 345678, but can be positioned to display 123456 or other sets of six digits.





3.3 Setting Time and Date



NOTE: Time and Date are standard and factory installed on the 4", 6", and 4" SG models.

The Time and Date (when enabled in the configuration menu) is displayed in three-second cycles (along with weight) when the displayed weight is zero or below.

To set time and date:

1. Go to **CONFIG** and enable Time and Date under **Enable** (Figure 3-3 on page 29).
2. Press  to enter the time in hours.
3. Press  to increment or decrement the hours.
4. Press  to set the hours and move to minutes.
5. Press  to increment or decrement minutes.
6. Press  to set the minutes and move to the month.
7. Repeat steps to set the month, day, and year.

3.4 Manual Configuration

To begin configuration:

1. Open the enclosure, see [Section 2.3 on page 12](#) for enclosure disassembly instructions.
2. Press **SETUP** on front panel overlay to access main menu configuration parameters.

Main menu parameters include:

- Configuration
- Serial communications
- Test
- Version

The LaserLight2 remote display can be configured using a series of menus accessed using the keys in [Figure 3-1](#).

3. Use  to navigate through menu items and **ENTER** to set a selection.

3.4.1 When External Keypad is Disabled

There may be instances where the external keypad needs to be disabled.

To disable external keypad:

1. Open the enclosure, see [Section 2.3 on page 12](#) for enclosure disassembly instructions.
2. Move the setup jumper (circled in [Figure 3-1](#)) to pin positions 2 and 3.
3. Press  (located on the CPU board) to enter into configuration mode.

Once the external keypad is disabled, proceed to configuration.

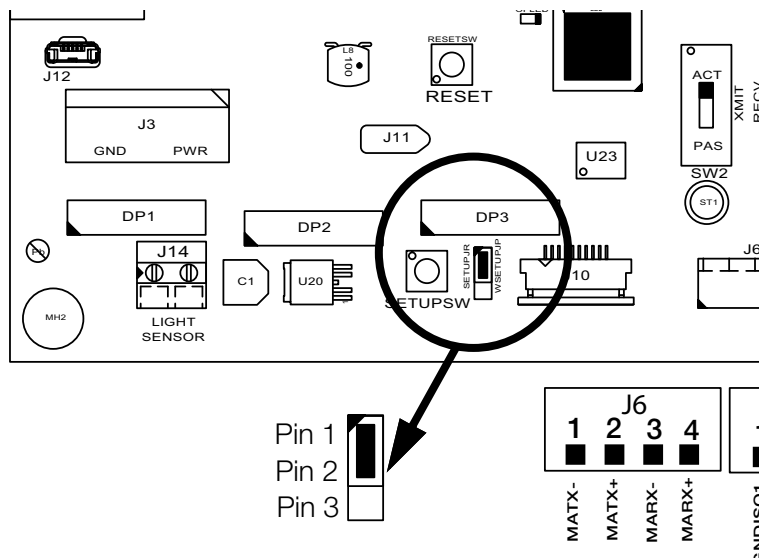

Figure 3-1. LaserLight2 Setup Switch Location on the CPU Board

3.4.2 Menu Navigation Using Keypad

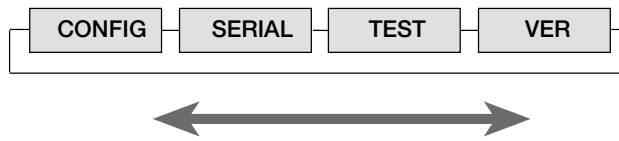

Figure 3-2. LaserLight2 Main Menu Options

Table 3-1 summarizes the functions of each of the main menus.

| Display Menu | Menu Function |
|--------------|---|
| CONFIG | Configures time and date (option), display brightness, mirroring, and other parameters associated with configuring the remote display |
| SERIAL | Configures serial ports |
| TEST | System hardware tests |
| VER | Displays installed software version number |

Table 3-1. Main Menu Functions

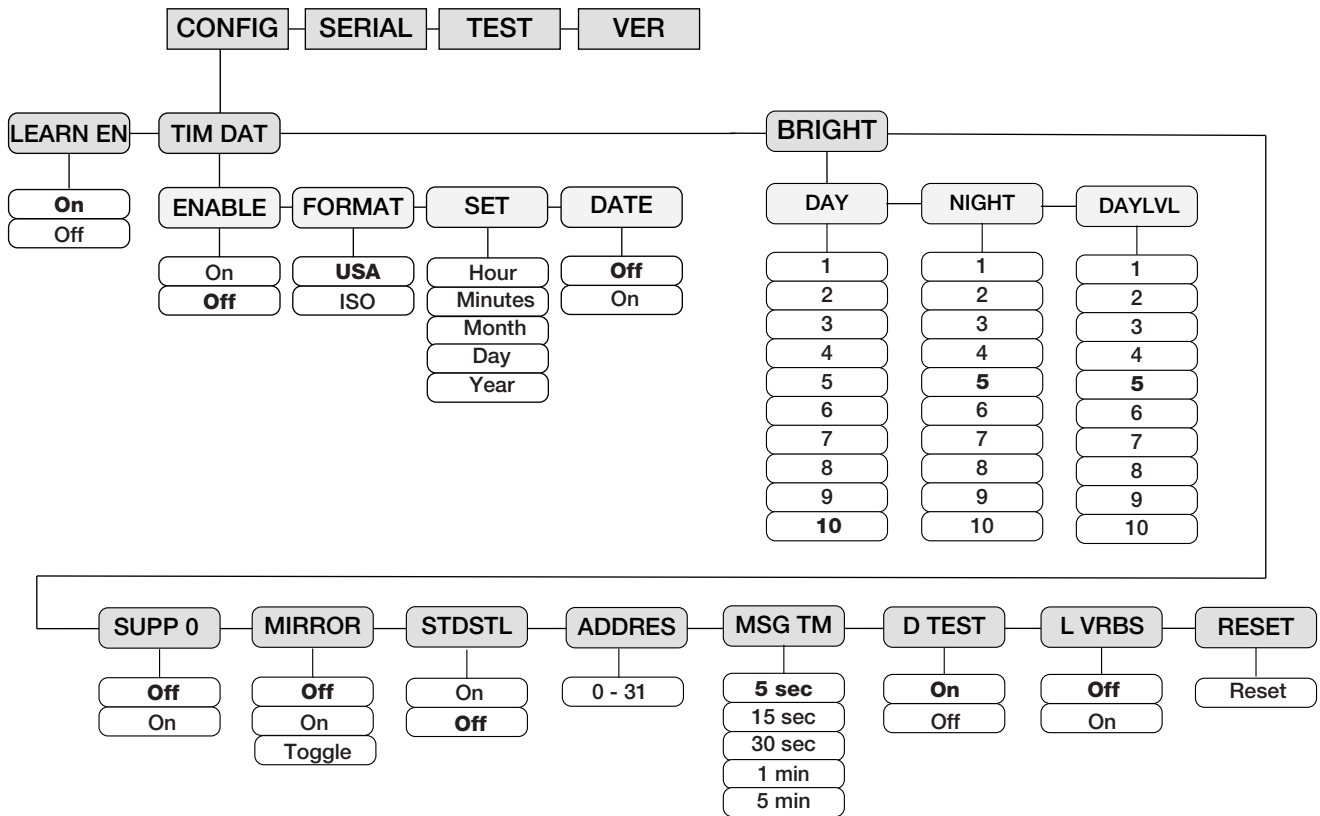

Figure 3-3. Configuration Main Menu Choices

| Parameter | Settings | Description |
|-------------------------|------------|---|
| Level 2 Submenus | | |
| TIMDAT | Enabled | Enable time and date |
| | Format | Displays USA or ISO time format |
| | Set | Sets hours/minutes and month/day/year |
| | Date | Disable date |
| BRIGHT | Day | Selects brightness during day or nighttime hours |
| | Night | If the ambient light sensor is not installed in the unit, the default settings are automatically set to night mode and are not adjustable |
| | DayLvl | |
| SUPP O | On | Select On to enable the suppression of leading zeros in a weight |
| | Off | |
| MIRROR | On | Select On to display LED readout in reverse; The menu is viewed normally |
| | Off | |
| | Toggle | Toggles between normal and mirrored image (if enabled) in 5-second intervals |
| STDSTL | On | Select On to enable display updated weight only when scale is not in motion |
| | Off | |
| ADDRES | 0–31 | Assign a command address by selecting a number from 0–31 |
| MSG TM | 5-seconds | Select amount of time a message stays on the remote display; Time can vary from 5-seconds to 5-minutes; If no serial command is used then this parameter is not used (7 segment DM command only) |
| | 15-seconds | |
| | 30-seconds | |
| | 1-minute | |
| | 5-minutes | |
| D TEST | On | Set this parameter On to test display on start up |
| | Off | |
| L VRBS | Off | Learn Verbose; displays the baud rates as it cycles through them during the auto-learn process; Acts as a diagnostic tool |
| | On | |
| RESET | -- | Reset remote display to default parameters |
| LEARN EN | On | Learn must be ON for streamed data; With Learn off, unit operates for demand messages and commands only and does not display streamed weight data; Messages can display and commands acted on while remote display receives streamed data |
| | Off | |

Table 3-2. Level 2 Configuration Parameters

| Parameter | Settings | Description |
|--|------------|---|
| Level 3 Submenus | | |
| ENABLE | On | Select On to enable time and date option; Time and date display if display is at zero or below |
| | Off | |
| FORMAT | USA | Display either USA or ISO (military time) format |
| | ISO | |
| SET | HH/MM | Set hour/minutes and month/day/year |
| | MM/DD/YYYY | |
| DATE | On | Off disables date display when date and time option is installed, date is always displayed |
| | Off | |
| Brightness (BRIGHT Parameter) If the ambient light sensor is not installed in the unit the default settings are automatically set to night mode; All lighting selections are environmentally dependent and may require some trial and error to achieve optimal brightness setting | | |
| DAY | 1-10 | Select brightness during day; Brightness is set from 1-10 (10-100%) of full brightness; IntelliBright averages measured ambient light over a 5-second time span; Day values = % of maximum brightness in the following chart, see Figure 3-4 for day brightness information |
| NIGHT | 1-5-10 | Select brightness during night; Brightness is set from 1-10 (10-100%) of full brightness; IntelliBright averages measured ambient light over a 5-second time span; Night values = % of maximum brightness in the following chart, see Figure 3-5 for night brightness information |
| DAYLVL | 1-3-10 | DYLVL is the ambient brightness threshold at which the display changes from night to day mode and vice versa; Settings range between 1 and 10 with 1 requiring less intense light to change to day mode and 10 requiring more intense light to change from night to day mode; Select the daylight level at which the display switches to DAY brightness mode; This may require some trial and error, due to the unique lighting conditions of the environment |

Table 3-3. Time and Date Brightness Parameters

Day Brightness Chart

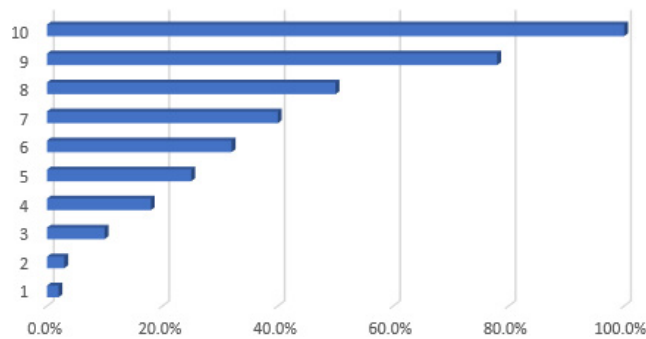

Figure 3-4. Percent of Full Day Brightness

Night Brightness Chart

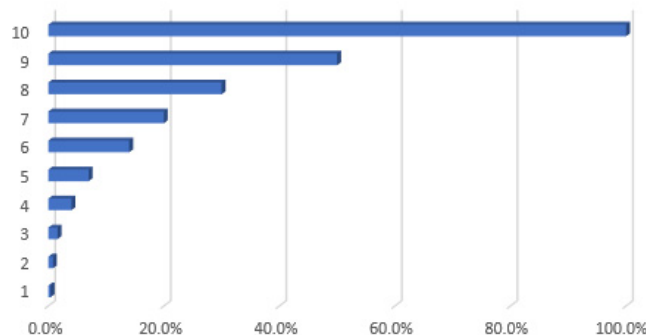

Figure 3-5. Percent of Full Night Brightness

3.5 Serial Communications

The LaserLight2 remote display has two serial ports available:

- Port 0 - Communicates with indicator and can receive data if daisy-chained from a second LaserLight2
- Port 1 - Provides echoing of indicator data

See [Section 2.5.2 on page 18](#) for serial wiring positions.

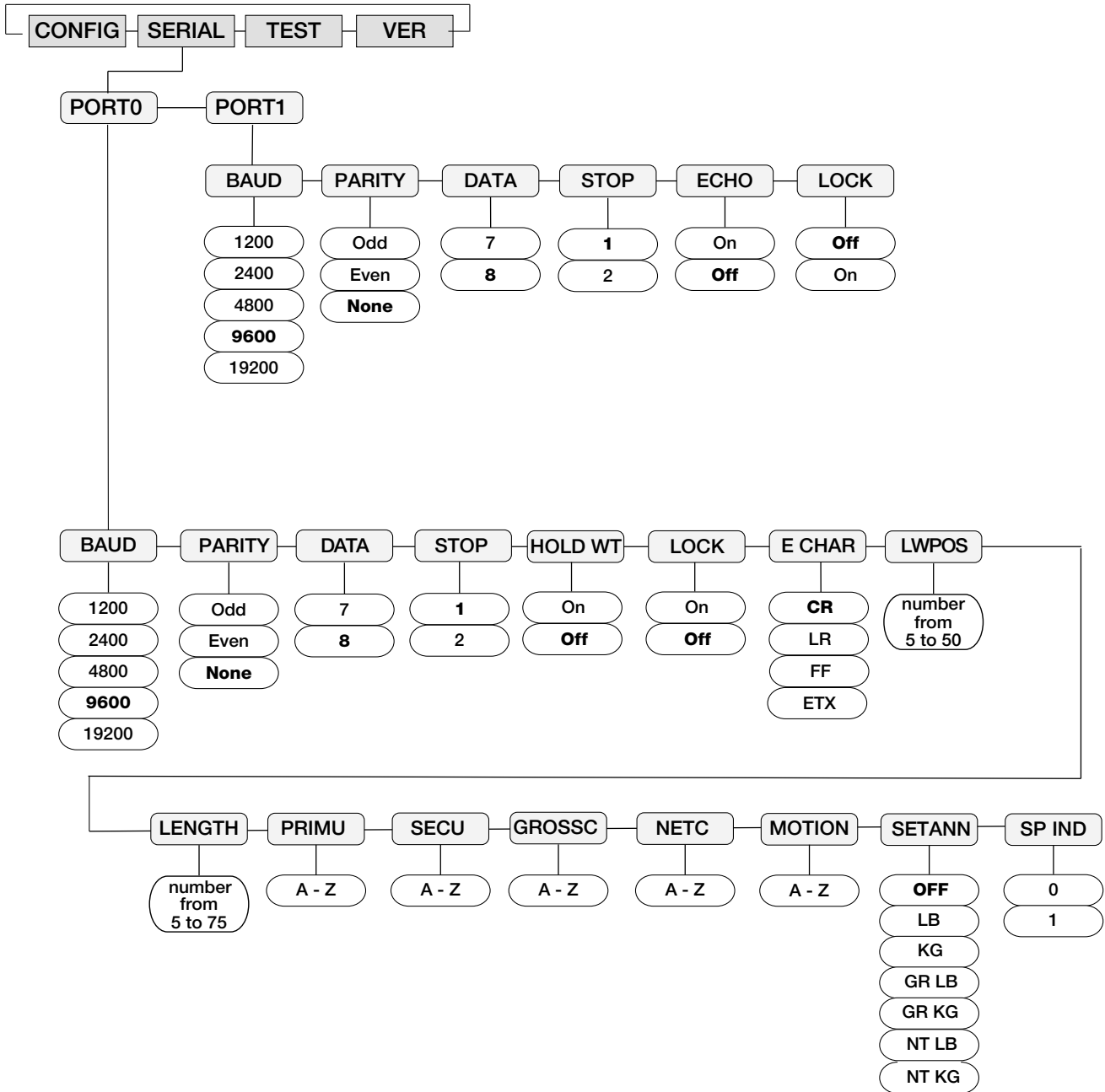

Figure 3-6. Serial Menu

| Parameter | Settings | Description |
|--|--|--|
| Level 2 Submenus | | |
| Port 0 | BAUD | Configure Port 0 – See level 3 submenu parameter descriptions (Table 3-5 on page 34) |
| | PARITY | |
| | DATA | |
| | STOP | |
| | HOLD WT | Holds last weight displayed if communication is lost and prevents remote display from going into an error condition |
| | LOCK | If enabled, prevents the Auto-Learn parameter from working and ensures settings remain as currently set, unless manually adjusted (Section 3.1 on page 25) |
| | E CHAR | Determines the end character of a packet when Auto Learn is enabled |
| | LW POS | Determines the last weight position of the format; Select a number from 5–50 |
| | LENGTH | Determines the length of packet in the string format; Select a number from 5–75 |
| | PRIM U | Select primary unit characters* |
| | SEC U | Select secondary unit characters* |
| | GROS C | Select gross character* |
| | NET C | Select net character* |
| | MOTION | Select motion status character* |
| | SETANN | Select which annunciators are enabled manually* |
| SP IND (special indicators) | Select, decode status, and settings for special indicator type 0 = automatic learning 1 = catch-all, semi-automatic learning NOTE: Only available if the parameter, Special Indicators is set to Mode 1 (Catch-all). | |
| PORT 1 | BAUD | Configure Port 1 – See level 3 submenu parameter descriptions (Table 3-5 on page 34) |
| | PARITY | |
| | DATA BITS | |
| | STOP BITS | |
| | ECHO | Allows echoing between remote display and other devices; Data settings are recommended to be set equal to or greater than device being echoed to |
| | LOCK | Select On to ensure current settings are not changed; If Auto-Learn is not locked, it mirrors port 0 serial settings |
| NOTE: *If selected, the appropriate annunciator is lit. | | |

Table 3-4. Level 2 Parameters

| Port 0 Parameter | Settings | Description |
|--------------------------------|-------------|--|
| Level 3 Submenus | | |
| BAUD | 1200 | Select transmission speed |
| | 2400 | |
| | 4800 | |
| | 9600 | |
| | 19200 | |
| PARITY | ODD | Select data parity |
| | EVEN | |
| | NONE | |
| DATA | 7 | Select number of data bits |
| | 8 | |
| STOP | 1 | Select number of stop bits |
| | 2 | |
| HOLD WT | ON | To prevent display from going into an error condition, select On to hold last weight displayed |
| | OFF | |
| LOCK | ON | On ensures current port settings are not changed and prevents Auto-Learn function; Off enables Auto-Learn function for port settings |
| | OFF | |
| E CHAR | CR | Determines the end character of a packet when Auto Learn is enabled |
| | LR | |
| | FF | |
| | ETX | |
| LW POS | 5–50 | Select a number from 5–50 to determine the last weight position; If Port 0 is set up manually, the last weight position is zero indexed <i>Example: <STX>123456<CR> where <STX> is the start of the text character, and <CR> is a carriage return character, the 6 is in the 6th position, not the 7th.</i> |
| LENGTH | 5–75 | Select a number from 5–75 to determine the length of the packet in the string format; Formats such as Toledo end in CR<AA> where <AA> is a 2-byte checksum, the checksum must not be counted when calculating the format length |
| PRIM U | A–Z | A primary display character from A–Z; Annunciator is illuminated when selected |
| SECD U | | A secondary display character from A–Z; Annunciator is illuminated when selected |
| GROS C | | A gross character from A–Z; Annunciator is illuminated when selected |
| NET C | | A net character from A–Z; Annunciator is illuminated when selected |
| MOTION | | A motion display character from A–Z; Annunciator is illuminated when selected |
| SETANN | | OFF |
| | LB | Sets only the lb annunciator on |
| | KG | Sets only the kg annunciator on |
| | GR LB | Sets only the GR and lb annunciators on |
| | GR KG | Sets only the GR and kg annunciators on |
| | NT LB | Sets only the NT and lb annunciators on |
| | NT KG | Sets only the NT and kg annunciators on NOTE: Only available in Special Indicator mode 1 (Catch-All). |
| SP IND (special indicators) | 0 | Off (Select when not using a special indicator) |
| | 1 | Catch-All mode; requires manually setting the baud rate, bits, and parity then setting the lock parameter to ON |

Table 3-5. Port 0, Level 3 Parameters

| Port 1 Parameter | Settings | Description |
|-------------------------|-------------|--|
| Level 3 Submenus | | |
| BAUD | 1200 | Select transmission speed for Port 1 |
| | 2400 | |
| | 4800 | |
| | 9600 | |
| | 19200 | |
| PARITY | ODD | Select data parity transmitted from Port 1 |
| | EVEN | |
| | NONE | |
| DATA BITS | 7 | Select number of data bits transmitted from Port 1 |
| | 8 | |
| STOP BITS | 1 | Select number of stop bits transmitted from Port 1 |
| | 2 | |
| ECHO | ON | Allow echoing between remote display and other devices; If parameter is ON, the baud setting must be set to equal or greater than the device being echoed to |
| | OFF | |
| LOCK | OFF | When set to OFF, the echo port display uses same communications settings as the indicator after an Auto Learn is run |
| | ON | |

Table 3-6. Port 1, Level 3 Parameters

3.6 Testing the Remote Display

The LaserLight2 remote display provides tests to check the hardware of the remote display. The tests can be accessed through the main menu.

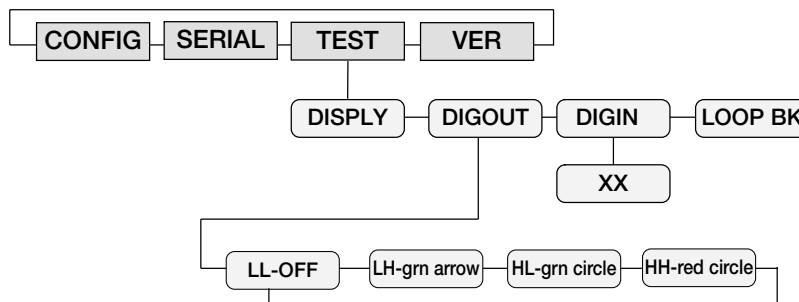

Figure 3-7. Test Menu Choices

3.6.1 Display

In the display test, all LEDs are illuminated and remain lit until **ENTER** is pressed.

3.6.2 Digital Outputs

This test provides a way to view the different states of digital outputs or stop/go option, if installed. Use the left and right arrows to increment/decrement and display each of the states, which are digital values of the two ports. On/Off terminology includes:

- Low (L) = ON = 0 V
- High (H) = OFF = +5 V

| Digital Out 1 J1 - 6 | Digital Out 0 J1 - 5 | Stop/Go Signal |
|----------------------|----------------------|-----------------|
| L | L | Off |
| L | H | Green Arrow On |
| H | L | Green Circle On |
| H | H | Red Stop |

Table 3-7. Digital Output States

See [Figure 2-6 on page 17](#) for plug positions.

1. Press the **Right Arrow** key again to display LL and the stop/go option displays no light.
2. Press the **Right Arrow** key again to display LH and the stop/go option displays a green arrow.
3. Press the **Right Arrow** key again to display HL and the stop/go option displays a green circle.
4. Press the **Right Arrow** key again to display HH and the stop/go option displays a red circle.

3.6.3 Digital Inputs

The digital input test displays current values read from the digital inputs.

3.6.4 Loop-back

This test provides a loop-back self test for use in diagnosing serial communications errors. The loop-back self test checks the function of the remote display serial port by sending and receiving data to itself. See [Figure 3-8](#) for required connections.

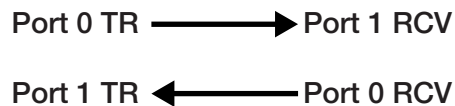

Figure 3-8. Loop-back

If Port 1 receives nothing from Port 0 for three seconds, **Fail 1** displays.

If Port 0 receives nothing from Port 1 for three seconds, **Fail 2** displays.

If communications are successful between the two, **Pass** displays.

3.7 Version

The current software version displays on remote display.



Figure 3-9. Version Menu

3.8 Demand Print Displaying

The indicator and LaserLight2 remote display can be set up to demand print display.

Demand print display is set up using Auto Learn when the Port 0 **Hold Weight** parameter is turned on. It can also be set up manually by configuring the Port 0 parameters of the remote display and indicator.

Using Auto-Learn, ensure **HOLD WT** is on and continuously push the print button on the indicator to attempt a demand print display.

3.9 Serial Commands

The LaserLight2 has the ability to receive commands, display messages, or use a digital I/O (2 inputs and 2 outputs). When interfaced to an indicator which has a configurable serial string, the print ticket format can be configured, allowing the user to press **Print** on the indicator and send a message which temporarily interrupts the streamed weight display. The length of time the message displays is defined by the **MSG TM** (message time) parameter in the **CONFIG** menu (Figure 3-3 on page 29).

If the LaserLight2 remote display is interfaced with a programmable smart indicator, a user program can be written allowing the user to send messages utilizing softkeys or events. The user can send one message to temporarily override the streamed weight display (Learn Enable is ON); or send multiple messages to be displayed one at a time, replacing the weight display (Learn Enable is OFF and no streamed weight data is available).

The remote display accepts serial commands to return the current time and date or to set the time and date to a new setting. This information can be used in conjunction with user programs in the indicator and remote display to ensure both have the same time and date settings.

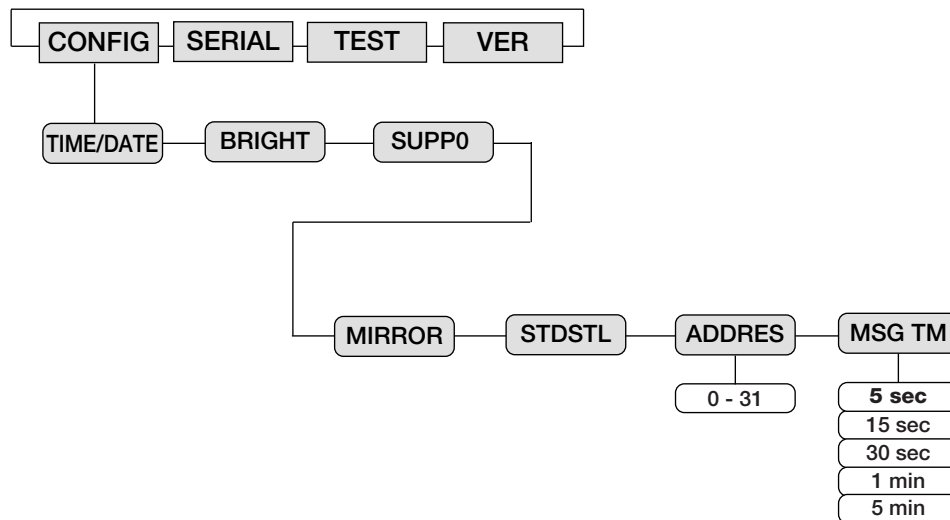

Figure 3-10. Assign Address and Message Timed

3.9.1 Remote Display Command Format:

The following is an example format string if using a display message on a 4", 6", and Stop/Go remote.

|<AA><CC>|<Data>!

Where:

| = Pipe character (0x7C)

AA = Two byte address, ASCII digits (0-31)

CC = Two byte command, ASCII characters

| = Pipe character (0x7C)

Data = Data depending on command

! = Exclamation point character (0 x21)



Note

Commands, GT, ST, DI, DO, GR, SR, GV, DC, and the feedback results are not displayed on remote display.

Display message commands must not be sent faster than once every second.

| Command | Description | Examples |
|---|--|--|
| DM | Display message <Data> is a six character message | 00DM HELLO ! Alternative command 00DM HELLO ! |
| GT | Get time and date; Information gathered is sent back to the indicator; Ensure both remote display and indicator match | 00GT! |
| ST | Set time and date NOTE: Two spaces are required between time and date entries. Time must be entered in a 24-hour format. | 00ST08:00:00 2003-01-31! 00ST15:00:00 2003-01-31! To obtain a P.M. time of 3:00P.M. |
| DI | Read digital input levels (returns "0"=LL, "1"=LH, "2"=HL, "3"=HH), see Section 3.9.2 on page 39 for further examples | 00DI! |
| DO | Set digital output levels ("DO0"=LL, "DO1"=LH, "DO2"=HL, "DO3"=HH), see Section 3.9.2 on page 39 for further examples | 00DOx! Where x references numbers 0–3 |
| GV | Get the version number | 00GV! |
| DC | Dump configuration parameters (for testing purposes only) | 00DC! |
| Time and date are sent from remote display in the current time format of remote display; Time and date are sent to remote display in ISO format; USA Format: HH:MM:SS AM/PM MMM/DD/YYYY ISO Format: HH:MM:SS YYYY-MM-DD If the real time clock is disabled in the remote display, an error message is sent back | | |

Table 3-8. Remote Display Commands

3.9.2 Set or Get the Digital I/O

Dry Contact Wiring

The Dig 0 and Dig 1 pins on the traffic light board (pin 2 and pin 3 on connector J1 respectively) have pull up resistors which allow operation of the traffic light can be controlled by switching Dig 0 or Dig 1 (or both) to ground.

 **NOTE:** Pressing the reset button on the LaserLight2 CPU board sets the D0 and D1 pins on the LaserLight2 CPU (pins 5 and 6 on J1) to a high pulled up state, which is the default state of the traffic light to be a stop light (red).

Single Switch Wiring

The user must select two of the four possible states if they want a single switch used for controlling the traffic light.

Two Switch Wiring

It is possible to obtain a variety of combinations of the four possible states using two switches to control the traffic light.

- Both switches with contacts closed give the OFF condition
- Both switches with contacts open give the STOP condition
- One switch open and the other closed gives either the Go or Arrow condition

| Signal | Digital 1 Signal J1- 6 | Digital 0 Signal J1 - 5 |
|--------|------------------------|-------------------------|
| Stop | Open (H) | Open (H) |
| Arrow | Open (H) | Closed (L) |
| Go | Closed (L) | Open (H) |
| Off | Closed (L) | Closed (L) |

Table 3-9. Traffic Option Wiring

Connect Digital 1 Example

1. Disconnect wire connecting D1 (pin 6 on J1) of CPU to Digital 1 (pin 3 on J1) of the traffic light pcb at the CPU connector.
2. Solder the wire going to Digital 1 on traffic light board to the wire which goes to the switch.
3. Place wires back into the connector on the CPU board (pin 6 on J1).
4. Connect other end of the switch wire to one pole of the switch.
5. Connect the remaining switch pole to the digital ground of the indicator. If a common ground between the indicator and the LaserLight2 does not exist (fiber optic communication is used), an additional wire is needed for connecting the switch to the ground on the LaserLight2 CPU board.

 **NOTE:** This connection does not harm the CPU board since digital outputs on CPU board are designed to be pulled low. The digital outputs are set to High (OFF) on reset.

To use the two Digital Inputs and Digital Outputs, use J1 to connect and use the following message command formats to set or get the Digital I/O (Figure 2-6 on page 17).

| Traffic Light State | Dry Contact | Serial Commands |
|---------------------|------------------------------------|-----------------|
| Stop | Dig0 and Dig1 open circuit | 00DO3! |
| Green Circle | Dig0 open circuit; Dig1 pulled low | 00DO2! |
| Green Arrow | Dig0 pulled low; Dig1 open circuit | 00DO1! |
| Off | Dig0 and Dig1 pulled low | 00DO0! |

Table 3-10. Serial Commands (Basic Configuration)

Digital Input and Output Examples

Get Digital input levels (all digin)

|00DI!

Response: 0 = LL, 1 = LH 2 = HL, 3 = HH

Set Digital output levels to HH (all digout = +5V)

|00DO0! = LL

|00DO1! = LH

|00DO2! = HL

|00DO3! = HH

Response: OK = success (states: DO0=DO1=+5V) or ?? = error

3.10 Updating the LaserLight2 Firmware

To update the LaserLight2 firmware:

1. Go to the Rice Lake website www.ricelake.com and search for the LaserLight2.
 - Select LaserLight2
 - Select Resources/Downloads
 - Select Firmware and Download
2. Unzip the file and drag the .bin file to a known location on the PC.
3. Power off the LaserLight2.
4. Connect a Micro USB type B connector to the LaserLight2 CPU board and the PC.

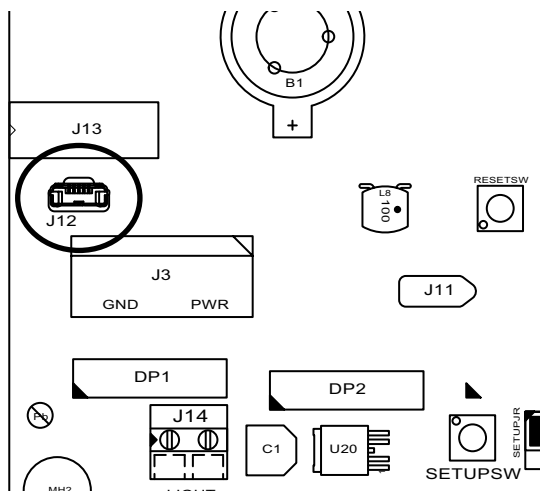

Figure 3-11. USB Type B Location on CPU Board

5. Power on the LaserLight2.
6. The PC recognizes it as a mass storage device.

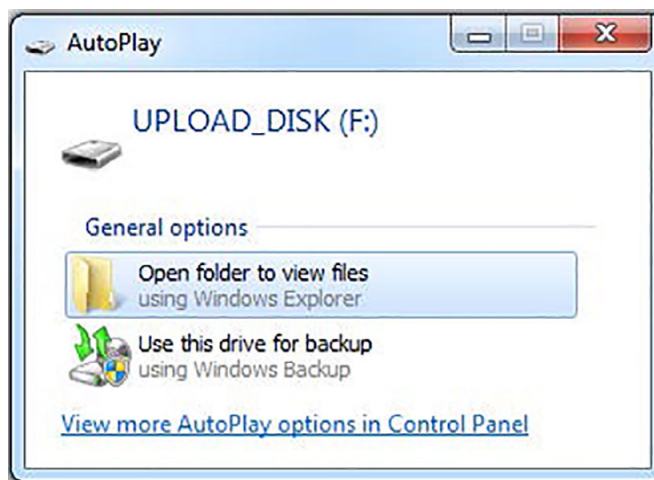

Figure 3-12. Open Folder

7. Open the folder.
8. Drag and drop the .bin file into the folder. The folder closes.
9. Disconnect the USB type B connector from the LaserLight2.
10. Power cycle the LaserLight2.

4.0 Options

This section provides an overview of LaserLight2 Series options.

Options available for the LaserLight2 display:

- Fiber-optic interface
- Radio interface
- Visor kit
- Pole mount kit

4.1 Fiber-Optic Interface

The fiber optic interface (PN 77788) allows for an optically-isolated connection between two devices. It eliminates electrical disturbance transferred on the communication line between devices. It also resolves potential differences due to a difference in grounding between the devices. The fiber optic cable can be run up to 300'.

Refer to PN 175664 for installation instructions of the fiber optic interface.

4.2 Radio Interface

A ConnexLink Wireless Radio (PN 175052) system is available for the 4" and 6" LaserLight2 remote displays and allows for communication between the remote display and an indicator with the matching radio installed. Refer to the ConnexLink Wireless Radio System Installation Instructions (PN 180704).

4.3 Visor Installation Kit

An optional visor can be installed on the LaserLight2. See [Figure 4-1](#) for the remote display with the optional visor installed.

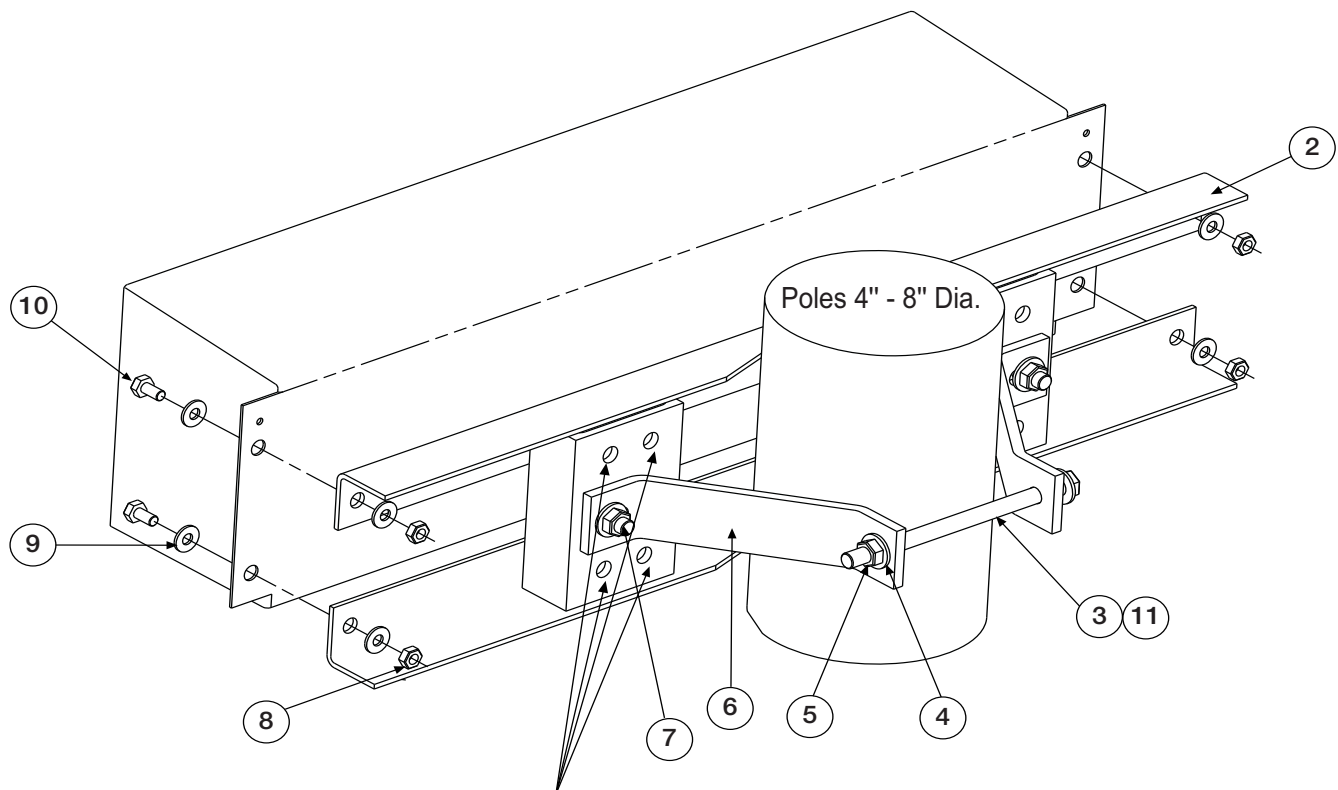

Figure 4-1. LaserLight2 Remote Display With Optional Visor Installed

Set the visor (PN 181224 - 4" model) or (PN 181801 - 6" model and 4" Stop/Go) on top of the remote display and attach the visor using screws and plastic washers provided.

4.4 Pole Mount Kit

The LaserLight2 remote display can be mounted horizontally on a pole using the 2-6" Diameter Pole Mounting Kit (PN 177865). Alternatively, the LaserLight2 can use the Flange Pole Mount Assembly (PN 75856 or PN 77775).



Holes for two brackets on each side of pole for 6" LaserLight remote display

Figure 4-2. LaserLight Pole Mount Assembly

| Item No. | Part No. | Description |
|----------|----------|---|
| 2 | 77000 | Weldment, Pole Mounting (4" Model - 1) |
| | 76998 | Weldment, Pole Mounting (6" Model - 1) |
| 8 | 14635 | Nut, Lock 1/4-20NC Hex (4) |
| 3 | 14747 | Bolt, 3/8-16NCx2-3/4 Hex (4" Model - 1) (6" Model - 2) |
| 10 | 14955 | Screw, Cap 1/4-20NCx1/2 (4) |
| 7 | 15019 | Screw, Cap 3/8-16NCx1 HEX (4" Model - 2) (6" Model - 4) |
| 9 | 15145 | Washer, Plain 3/8 Type A (8) |
| 4 | 21938 | Washer, Plain Type A (4" Model - 4) (6" Model - 8) |
| 5 | 22072 | Nut, Lock 3/8-16NC Hex (4" Model - 3) (6" Model - 6) |
| 6 | 76999 | Bracket, Clinching Pole (4" Model - 2) (6" Model - 4) |
| 11 | 77001 | Screw, Mach 3/8-16NC (4" Model - 3) (6" Model - 6) |

Table 4-1. Parts Kit Contents

To install the pole mount option:

1. Attach the two clinching pole brackets to the pole using the enclosed 3/8" carriage bolts (grade 5), washers, and lock nuts from the parts kit.
2. Tighten the clinching pole brackets together using the enclosed 3/8" carriage bolts (grade 6), washers, and lock nuts. Tighten as necessary.
3. Align the back of the LaserLight2 remote display to the vesa mounting bracket, ensuring the holes line up.
4. Attach the mounting bracket to the remote display using the enclosed M6 cap screws, washers and nuts. Use a torque spec of 20-30 in/lb.

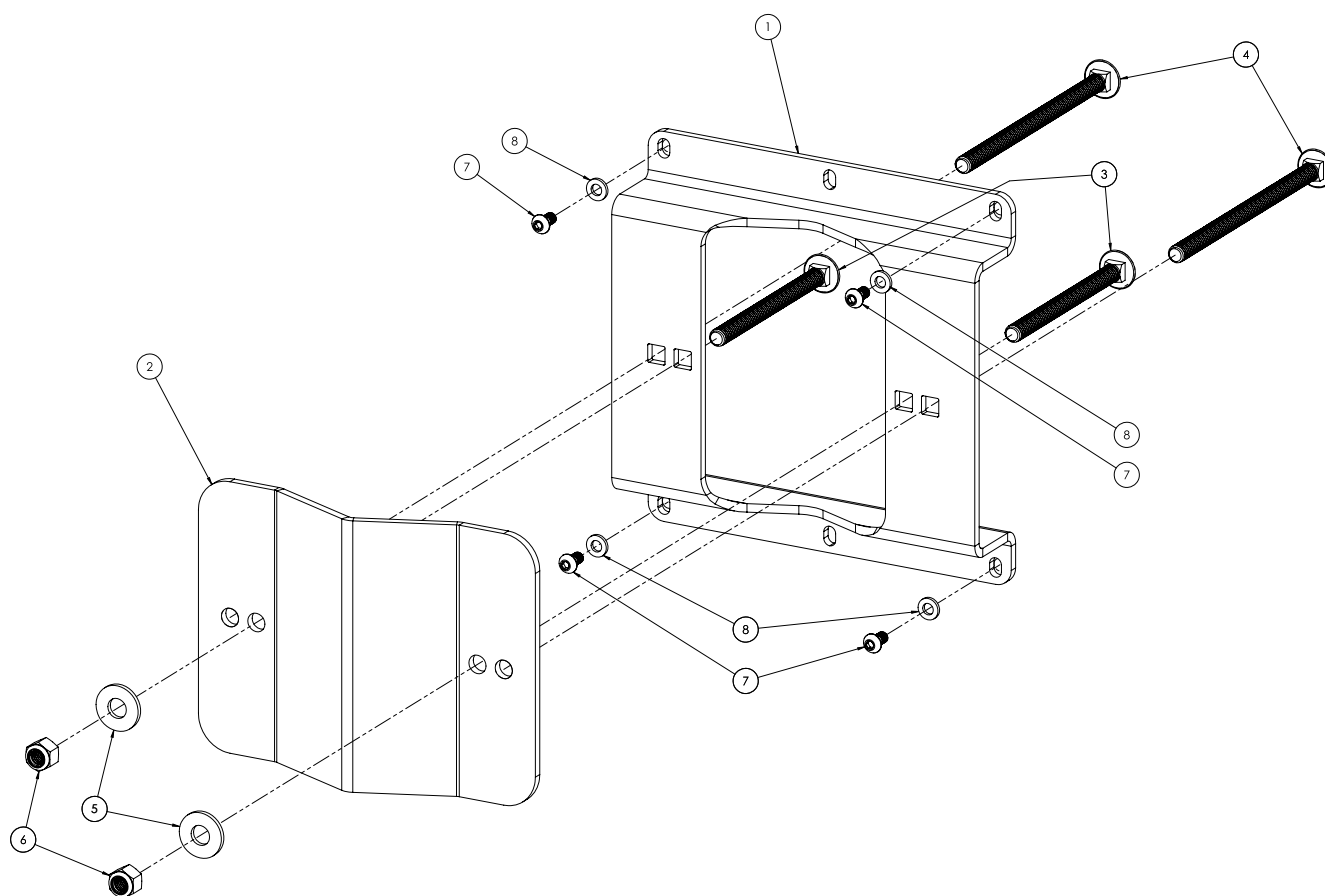

Figure 4-3. LaserLight2 Mount Assembly

| Item No. | Part No. | Description | Qty. |
|----------|----------|--|------|
| 1 | 177866 | Pole Mount Bracket | 1 |
| 2 | 177867 | Pole Clamp Bracket | 1 |
| 3 | 177871 | Bolt, 3/8-16 x 4-1/2 Grade 5 Full Thread | 2 |
| 4 | 177872 | Bolt, 3/8-16 x 4-1/2 Grade 6 Full Thread | 2 |
| 5 | 21938 | Washer, Plain 3/8 Type A | 2 |
| 6 | 22072 | Lock Nut, 3/8-16 Hex | 2 |
| 7 | 130869 | Metric M6 x 1 x 12 Button Head Cap Screw | 4 |
| 8 | 167958 | M6 Metric Flat Washer | 4 |

Table 4-2. Pole Mount Parts Kit

4.5 Offset Plate

The LaserLight2 can be offset mounted using the optional offset mounting bracket (PN 178790) mounted to the pole mount kit. The offset plate allows the left or right offset of the LaserLight2 to mount the pole (flange mounted). The flange mount requires the Vesa style pole mount ([Figure 4-3 on page 43](#)).

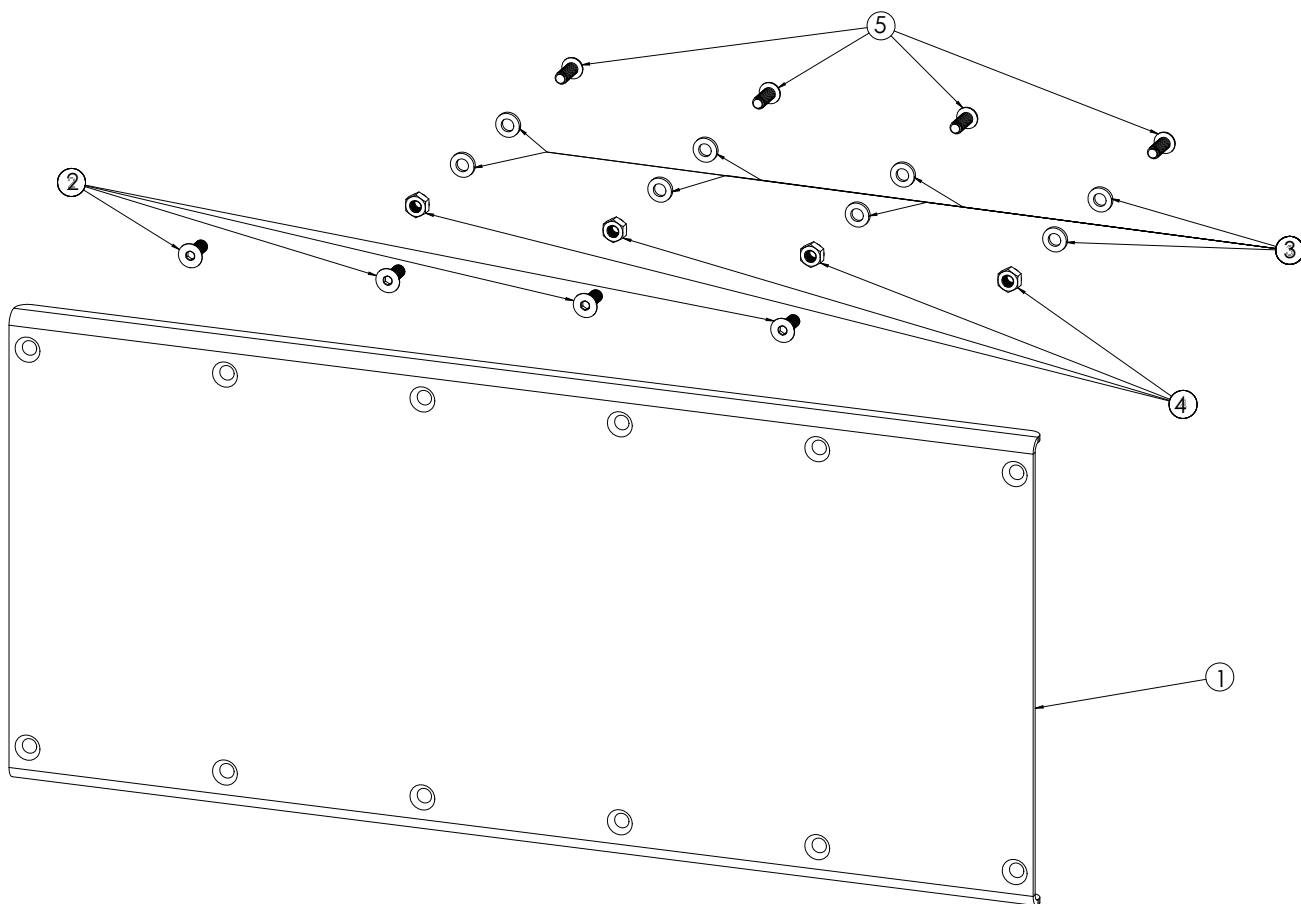

Figure 4-4. Offset Mounting Bracket Kit

| Item No. | Part No. | Description | Qty. |
|----------|----------|----------------------------------|------|
| 1 | 177868 | Plate, Offset Pole Mounting | 1 |
| 2 | 167299 | Screw, M6-1.0 x 16 mm Flat Head | 4 |
| 3 | 167958 | Flat washer, M6, Stainless Steel | 8 |
| 4 | 175921 | Nut, M6 x 16 mm | 4 |
| 5 | 178804 | Screw, Button Head M6 x 16 mm | 4 |

Table 4-3. Offset Mounting Bracket Parts Kit

5.0 Maintenance

This section provides an overview of LaserLight2 Series maintenance instructions.

5.1 Error Messages

The LaserLight2 displays an error message when an error occurs. [Table 5-1](#) lists the error messages and causes.

| Message | Description | Cause |
|---------------|------------------|---|
| <i>LError</i> | Auto Learn Error | Auto Learn failed |
| <i>BError</i> | Indicator Code | Write error; Could not save menu settings to the serial EEPROM |
| <i>rESEt</i> | Invalid Settings | Invalid settings upon power up; All settings reset to their default state |
| <i>rError</i> | Range Error | When the Rice Lake format goes over or under range |
| <i>dSPErr</i> | Display Error | Data cannot be accurately displayed |
| -- -- | Invalid Data | Data is being received but is not valid |

Table 5-1. Error Messages

5.2 Enclosure Dimensions

See the following information for the 22" unit (4" model enclosure) and the 31" unit (6" and Stop/Go model enclosures) dimensions.

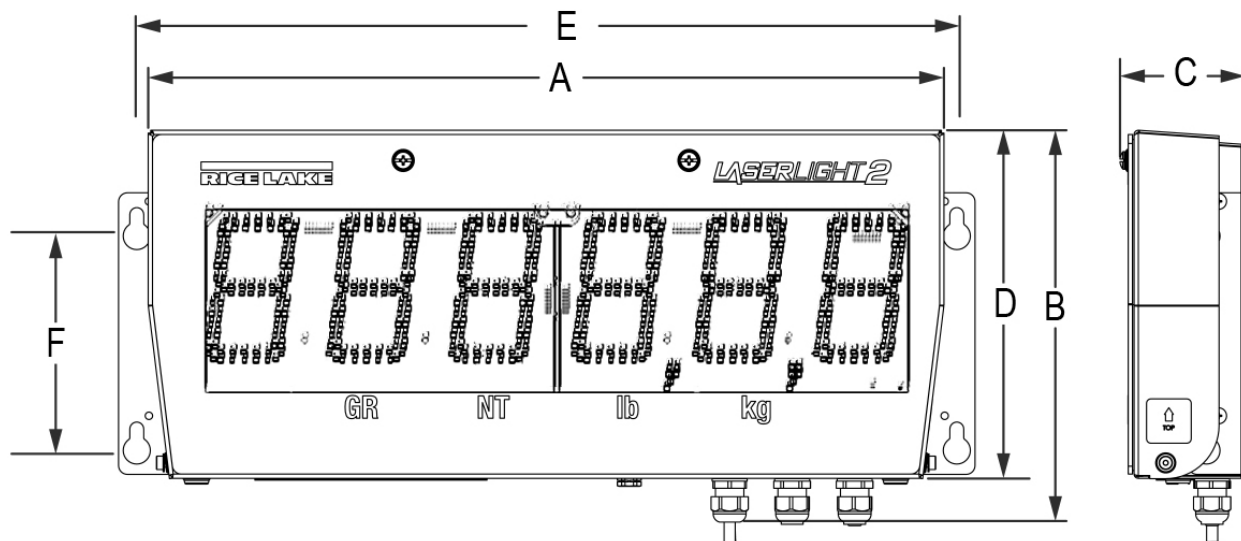

Figure 5-1. Model Enclosure Dimensions (4" Model Enclosure Shown)

| Key | 4" Model Enclosure Dimensions | 6" and Stop/Go Model Enclosure Dimensions |
|-----|-------------------------------|---|
| A | 22.28" (56.5 cm) | 30.63" (78.0 cm) |
| B | 10.96" (28.0 cm) | 13.94" (35.5 cm) |
| C | 3.28" (8.50 cm) | 3.73" (9.50 cm) |
| D | 9.80" (25.0 cm) | 12.77" (32.5 cm) |
| E | 23.00" (58.4 cm) | 31.00" (78.7 cm) |
| F | 6.00" (15.2 cm) | 7.75" (19.69 cm) |

Table 5-2. LaserLight2 Series Model Dimensions

6.0 Specifications

Power

| | |
|-------------------|------|
| Power Consumption | |
| 4" | 21 W |
| 6" | 27 W |

Operator Interface

| | |
|---------|---|
| Display | 6-digit, 7-segment discrete oval red LED lamps, dual width Contrast enhanced optical filtering lens 1- or 2-place decimal or comma indication 4 annunciators for GR, NT, lb, kg 4" red, green ball/arrow in Stop/Go model |
|---------|---|

Maximum Viewing Distance

| | |
|--------------------|--------------|
| 4" Model Enclosure | 250' (75 m) |
| 6" Model Enclosure | 300' (100 m) |

Serial Communications

| | |
|------------------|---|
| Input Interface | RS-232, RS-485 or 20 mA current loop (active or passive, switch selectable) |
| Output Interface | Independently configurable echo port, RS-232 or 20 mA current loop (active or passive, switch selectable) |
| RS-232 | Full and Half Duplex |
| RS-485 | Full and Half Duplex |
| Baud Rate | 1200, 2400, 4800, 9600, and 19200 self-learning or software selectable |
| Character Format | 7 or 8 data bits; even, odd, or no parity; 1 or 2 stop bits, self-learning or software selectable |
| Update | Continuous or out-of-motion only; software selectable |
| Time | Software enable/disable, 12- or 24-hour format |
| Date | Software enable/disable, US or ISO format |

Environmental

| | |
|-----------------------|--------------------------|
| Operating Temperature | -40°F–120°F (-40°C–49°C) |
|-----------------------|--------------------------|

Enclosure

| | |
|----------------------------|---------------------------|
| Enclosure Dimensions | |
| 4" Model Enclosure (L x H) | 22.28" x 9.8" |
| 6" Model Enclosure (L x H) | 30.63" x 12.77" |
| Stop/Go (L x H) | 30.63" x 12.77" |
| | (Flanges add 2.00" width) |

Weight

| | |
|--------------------|---|
| 4" Model Enclosure | 20 lb (9 kg) |
| 6" Model Enclosure | 25 lb (11 kg) |
| Rating | IP66 |
| Material | Weather tight, powder coated steel or stainless steel |

Warranty

Two-year limited warranty



© Rice Lake Weighing Systems Content subject to change without notice.

230 W. Coleman St. • Rice Lake, WI 54868 • USA USA: 800-472-6703 • International: +1-715-234-9171