

Master™ 221DB

Belt Scale Weigh Frame

Installation Manual



© Rice Lake Weighing Systems. All rights reserved.

Rice Lake Weighing Systems® is a registered trademark of
Rice Lake Weighing Systems.

All other brand or product names within this publication are trademarks or
registered trademarks of their respective companies.

All information contained within this publication is, to the best of our knowledge, complete and
accurate at the time of publication. Rice Lake Weighing Systems reserves the right to make
changes to the technology, features, specifications and design of the equipment without notice.

The most current version of this publication, software, firmware and all other product
updates can be found on our website:

www.ricelake.com

Revision History

This section tracks and describes manual revisions for awareness of major updates.

Revision	Date	Description
C	March 13, 2023	Established revision history
D	August 29, 2023	Added lever ratio information
E	October 18, 2024	Updated overload bolts procedure

Table i. Revision Letter History



Technical training seminars are available through Rice Lake Weighing Systems. Course descriptions and dates can be viewed at www.ricelake.com/training or obtained by calling 715-234-9171 and asking for the training department.

Contents

1.0 Introduction	5
1.1 Overview	5
1.2 Selection Criteria	5
1.3 Calibration Device and Test Weights	5
1.4 Safety	6
1.5 Disposal	6
2.0 Installation	7
2.1 Mechanical Installation	8
2.2 Electrical Installation	11
2.3 Commissioning	11
2.3.1 Mechanical Adjustments	11
3.0 Maintenance	12
3.1 Maintenance	12
3.1.1 Periodical Maintenance	12
3.2 Dimensional Drawings	12
3.3 List of Parameters for belt scale	13
4.0 Appendix	14
4.1 Specifications	14
4.2 Total Load Cell Build Conversion	14
4.3 Overload Bolts	14



Rice Lake continually offers web-based video training on a growing selection of product-related topics at no cost. Visit www.ricelake.com/webinars

1.0 Introduction

Belt scales measure a continuous mass flow, which is transported over a belt conveyor. A complete belt scale is composed of a weigh frame, which contains one or more load cells, a speed sensor/pickup and the integrator electronics.

Not every application is suited for a belt scale; this has to be analyzed by a Rice Lake Weighing Systems application specialist. To achieve the optimum result, the Master™ belt scale series has been developed for a number of applications and for every type of conveyor.



Manuals are available from Rice Lake Weighing Systems at www.ricelake.com/manuals

Warranty information is available at www.ricelake.com/warranties

1.1 Overview

The weigh frame model 221DB Belt Scale is designed for medium and heavier applications in the process industry and allows load cell mounting outside of the frame.

Theory of Operation

The material is carried by the belt and underlying rollers or idler stations. One or more of these idlers are mounted on the weigh frame and are used to weigh the material going across the belt. The material carried on the belt is weighed and the belt speed is measured. The integrator totals and calculates the mass flow. These values are displayed and transmitted through outputs or other forms of communication to a control system or network.

Refer to the manual of the installed integrator for more information on operation.

1.2 Selection Criteria

Load cell capacity is calculated based on the maximum belt load plus the dead load of the weigh frame and the weight of the rollers. Contact Rice Lake Weighing Systems technical support for assistance.

Net load = (conveyor capacity / belt speed) x idler spacing

Gross load = net load + (idler weight + belt weight + mounting hardware)

Examples:

Net load = (50,000 lb per minute / 400 feet per minute) x 4 foot spacing

Net load = (125 lb per foot) x 4 foot spacing

Net load = 500 lb

Gross load = 500 lb + (175 lb idler + 48 lb belt + 24 lb hardware)

Gross load = 747 lb

1.3 Calibration Device and Test Weights

Test weights are used to test repeatability and the state of the belt scale after initial calibration. Mounting points can be provided to apply static test weights.

To determine absolute accuracy, it is necessary to do a test with material. For this procedure, refer to the manual of the installed integrator for more information on operation.

1.4 Safety

Safety Definitions:



DANGER: Indicates an imminently hazardous situation that, if not avoided, will result in death or serious injury. Includes hazards that are exposed when guards are removed.



WARNING: Indicates a potentially hazardous situation that, if not avoided, could result in serious injury or death. Includes hazards that are exposed when guards are removed.



CAUTION: Indicates a potentially hazardous situation that, if not avoided, could result in minor or moderate injury.



IMPORTANT: Indicates information about procedures that, if not observed, could result in damage to equipment or corruption to and loss of data.

General Safety



Do not operate or work on this equipment unless this manual has been read and all instructions are understood. Failure to follow the instructions or heed the warnings could result in injury or death. Contact any Rice Lake Weighing Systems dealer for replacement manuals.



WARNING

Failure to heed could result in serious injury or death.

Some procedures described in this manual require work inside the enclosure. These procedures are to be performed by qualified service personnel only.

Take all necessary safety precautions when installing the weigh frame, including wearing safety shoes, protective eye wear, and using the proper tools.

Keep hands, feet and loose clothing away from moving parts.

Do not approach a running conveyor from underneath.

Do not bend over a running conveyor.

Do not allow minors (children) or inexperienced persons to operate this unit.

Do not operate without all shields and guards in place.

Do not jump on the scale.

Do not use for purposes other than weight taking.

Do not place fingers into slots or possible pinch points.

Do not use any load bearing component that is worn beyond 5% of the original dimension.

Do not use this product if any of the components are cracked.

Do not exceed the rated load limit of the unit.

Do not make alterations or modifications to the unit.

Do not remove or obscure warning labels.

Do not use near water.

1.5 Disposal



Product Disposal

The product must be brought to appropriate separate waste collection centers at the end of its life cycle.

Proper separate collection to recycle the product helps prevent possible negative effects on the environment and to health, and promotes the recycling of the materials. Users who dispose of the product illegally shall face administrative sanctions as provided by law.

2.0 Installation

Installation procedures generally should be a combination of the end user's best engineering practices in compliance with local codes and the manufacturer's recommendations. To achieve maximum performance, the following precautions should be observed.



WARNING: Take all necessary safety precautions when installing the scale carriage including wearing safety shoes, protective eye wear and using the proper tools.

Always turn off the power supply before any connection is made or removed.

Before welding, the power supply must be off and the connectors removed.

The load cell is very sensitive to damage by welding. The welding ground clamp must be attached to the same side of the weigh frame where welding. When in doubt, remove the load cell(s).



IMPORTANT: Follow the recommendations given when the application was checked.

Belt conveyor must be installed in a stable and rigid area, free from vibrations.

The construction of the belt frame must be stiff enough to prevent torsion or bending at the maximum load (including the weigh frame).

The weigh frame must be mounted free of mechanical tensions.

No vibrations in the conveyor should be allowed to carry over to the weigh frame. If needed, these must be filtered.

The belt must be of good quality and a single splice. A vulcanized splice will provide the best accuracy. The weight per foot (meter) should be consistent over the whole length.

The belt must not track out of the center and no steering idler must be placed near the weighing area.

The belt support must not be provided with two part (v-shape) idler stations.

At least three idler stations before and three idler stations after the weigh frame (the weighing section) have to be adjustable in height. For short belt conveyors this can be reduced to one roller before and one roller after the weigh frame.

String alignment should be used on all idlers in the scale system. If following the rule of three before and three after, seven idlers (including the weigh idler) should be checked during the alignment process.

Rollers should not have a concentricity exceeding +/- 0.012 in (0.3 mm).

The speed sensor should be mounted on a non-driven roller or drum.

The inclination angle of the belt conveyor must not exceed 25°.

Proper covers may be required to prevent air flow from interfering with the belt scale.

Side guards and belt skirting should not be in contact with the weighing area of the belt scale.

2.1 Mechanical Installation

The mechanical installation of a belt scale consists of mounting the weigh frame, the speed pickup and the junction box.

 **NOTE: Belt removed for illustration purposes only.**

1. Determine the location for the weighing idler. This location should be at least five idlers after the load point of the conveyor and at least five idlers before the head pulley.
2. Measure the center-to-center distance of the idlers. Note this for placement of the weigh frame and idlers.

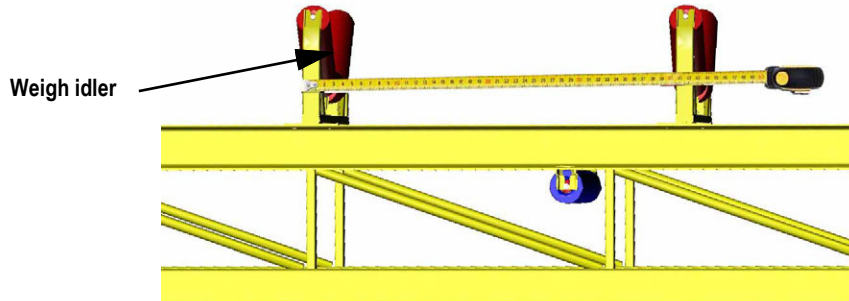

Figure 2-1. Measure Center-to-Center Distance of the Idlers

3. Remove the existing idler where scale is to be located.
4. Add mounting plate to the conveyor in order to mount scale if the conveyor stringer is less than 4 in (101.6 mm) or if the stringer channel is outward facing.

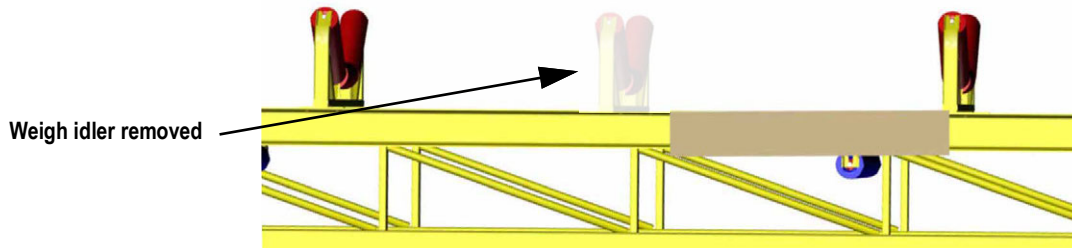

Figure 2-2. Add Mounting Plate To Conveyor

5. Modify the idler station to extend beyond the outside of the conveyor stringers in order to attach the 221DB Belt Scale weigh frame lever arms. Alternatively, idler frames with the same dimension and a wide base can be obtained from an idler manufacturer.

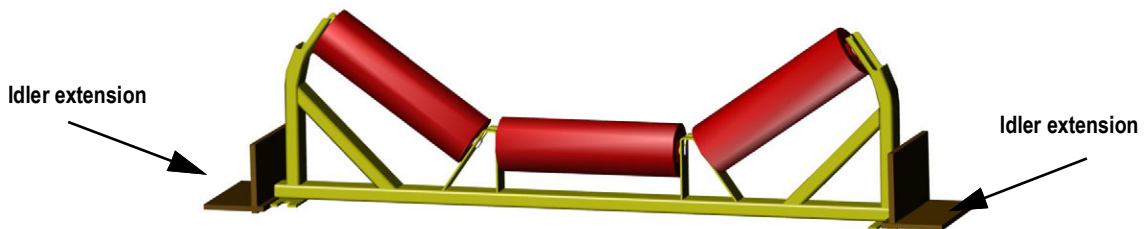

Figure 2-3. Modify Idler Station

 **NOTE: For illustration purposes only. A different modification may be required.**

- Remove lever arm from weigh frame assembly (only if necessary for mounting purposes).

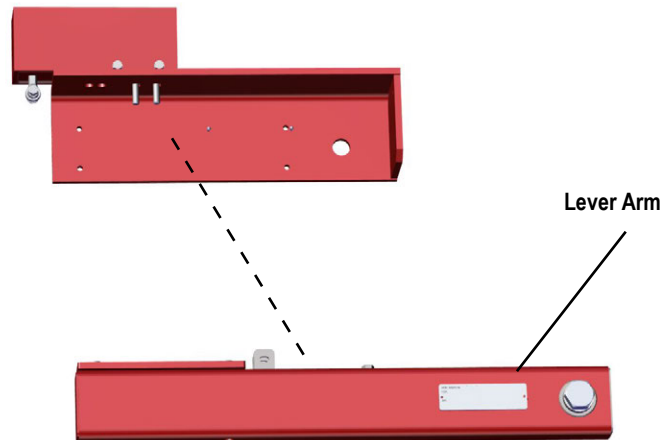

Figure 2-4. Remove Lever Arm

- Using clamps, position each weldment into the proper position. The top of the weigh frame should be positioned 1.5 in (38.1 mm) above the stringer to allow clearance for the idler station when bolted back into place (see [Figure 2-5](#)). Ensure the long end of the lever arm points in the same direction as the belt travel.
- Use a transfer punch to mark the bolt holes for drilling.
- After holes are drilled, secure weldment with four 3/8-16 (M10x1.25) bolts (not provided with 221DB Belt Scale). Ensure they do not interfere with lever arm.

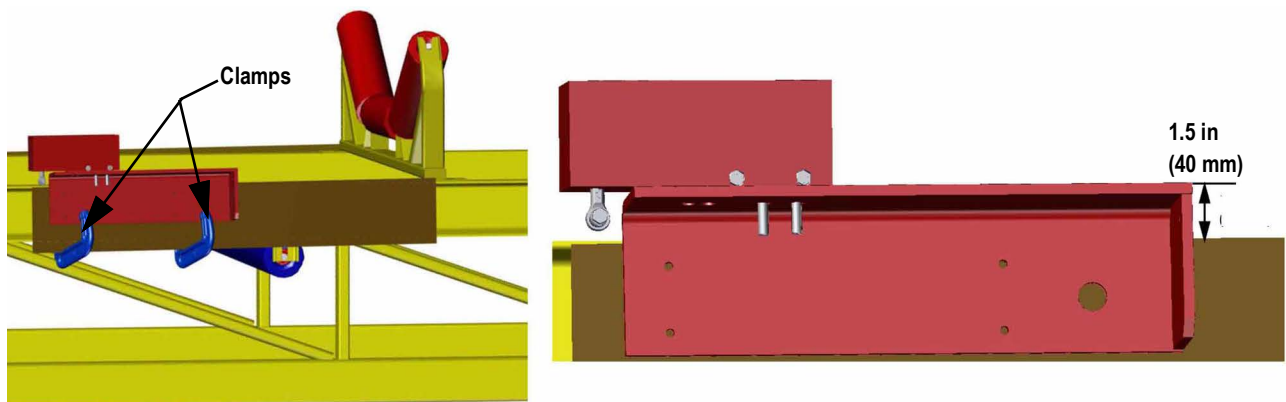

Figure 2-5. Use Clamps to Position Weldment

- After weldment is in place and secured, re-install lever arms.

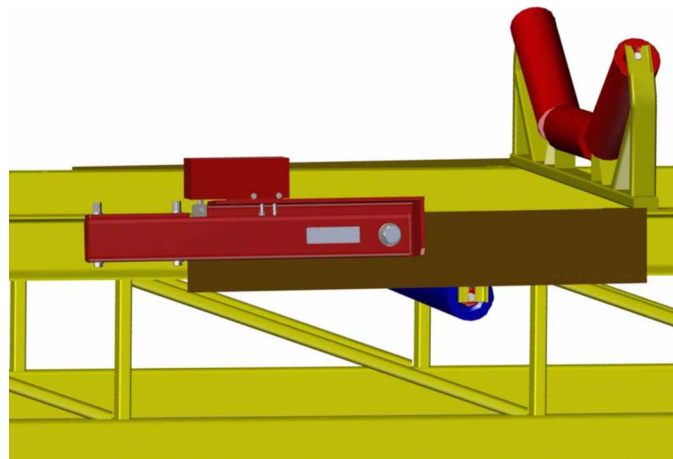

Figure 2-6. Re-install Lever Arms

11. Repeat installation on opposite side of conveyor. Make sure assemblies are aligned with each other.
12. Mount idler station to lever arms.

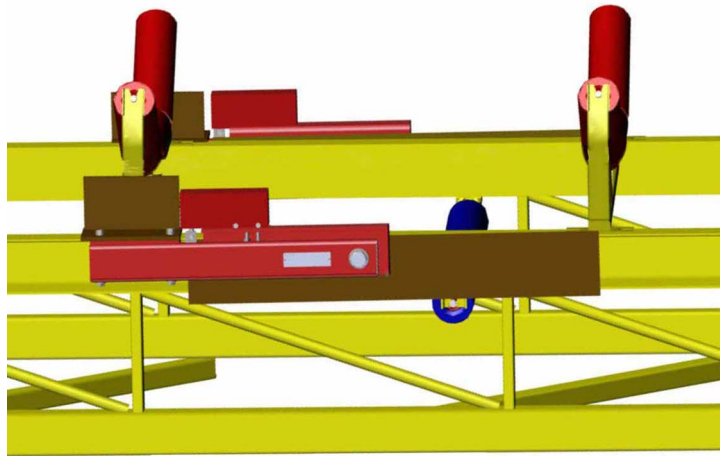

Figure 2-7. Mount Idler

13. Run strings on the conveyor (three before the scale and three past the scale) and shim the idlers to the same plane.

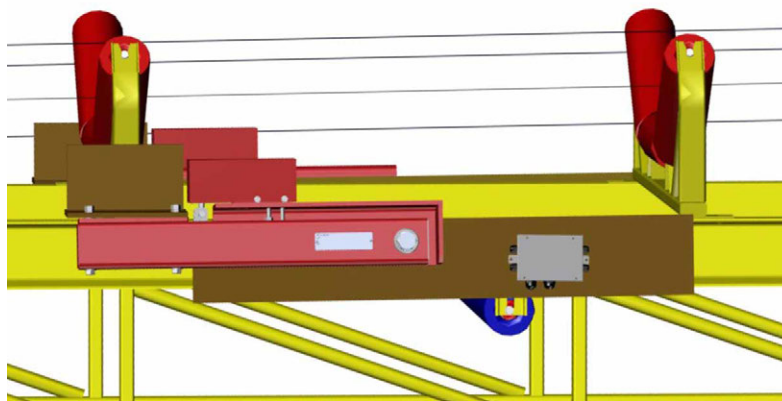

Figure 2-8. Run Strings to Same Plane

14. Mount junction box in appropriate location.

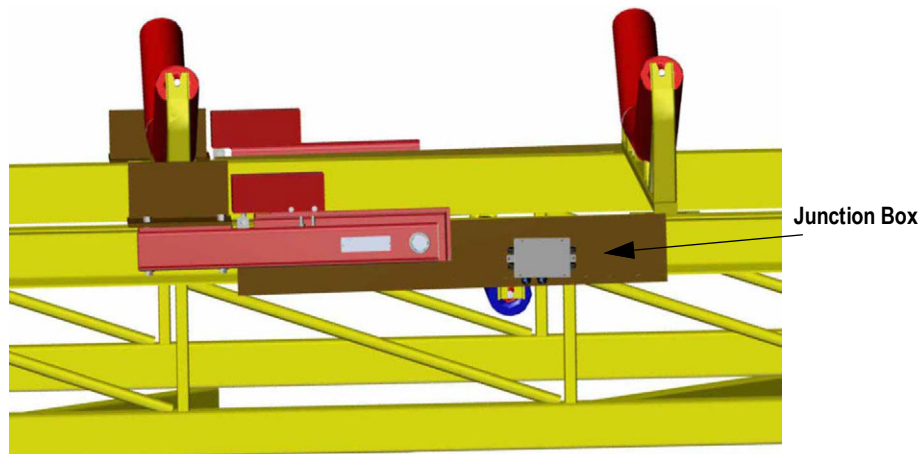

Figure 2-9. Mount Junction Box

15. Wire load cells according to the load cell data sheets and junction box manual.

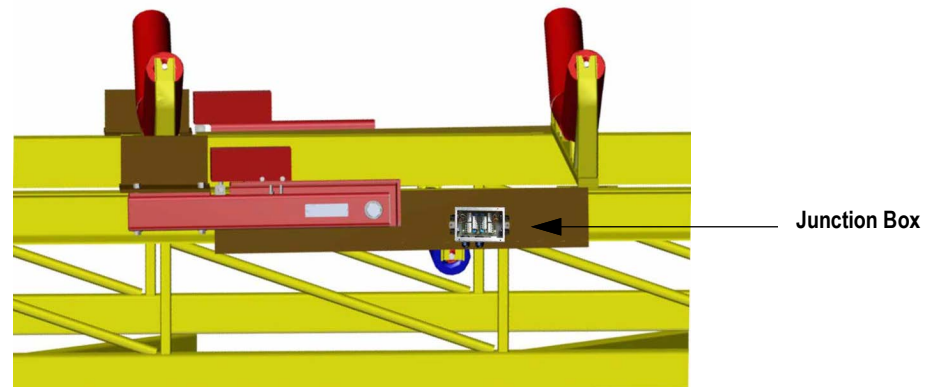

Figure 2-10. Wire Load Cells

16. Terminate home run cable at the junction box and integrator.
17. Adjust overload stops, see [Section 4.3 on page 14](#).
18. Calibrate the 221DB Belt Scale using the calibration procedure for the applicable integrator.

2.2 Electrical Installation

The load cell is provided with a fixed cable; do not alter the length. If necessary, use an additional junction box with screw terminals to extend the cable length.

Cable Types

Load cell

If the length is more than 197 ft (60 m), use shielded 6 wire cable 20 AWG gauge (0.5 mm²)

Speed pickup

Use shielded 3 wire cable 20 AWG gauge (0.5 mm²)

Shielding

Cable shielding must be connected to one side only. If connected to the instrument side, then it is preferred to use the same ground as the power supply.

2.3 Commissioning

Commissioning should be performed by service engineers who are trained and experienced with the subject.

2.3.1 Mechanical Adjustments

Mechanical adjustments must be made to ensure the scale is free of any tension. If necessary, the load cell can be adjusted.

3.0 Maintenance

Regular maintenance is essential to prevent errors or unnecessary down time. The supplier does not accept any responsibility for the consequences of not performing the maintenance recommended in this section.

3.1 Maintenance



WARNING: It is important to guarantee the safety of personnel during maintenance work and to assure no accidents will happen. Before any work on electrical systems is started, be sure to remove the main power supply.

The conveyor must be shut off before any work on the conveyor is started. Any goods on the conveyor must be removed first. No unauthorized persons are allowed in the conveyor's working area.

3.1.1 Periodical Maintenance

To keep the belt scale in optimal condition, it is important to perform periodical maintenance.

- Ensure there is not a build up of debris on the belt.
- Inspect the weigh frame for damaged areas and repair as necessary
- Regularly perform an Auto Zero and a weight check with certified test weights to determine if the belt scale weighs correctly. For this procedure, refer to the manual of the electronics installed

3.2 Dimensional Drawings

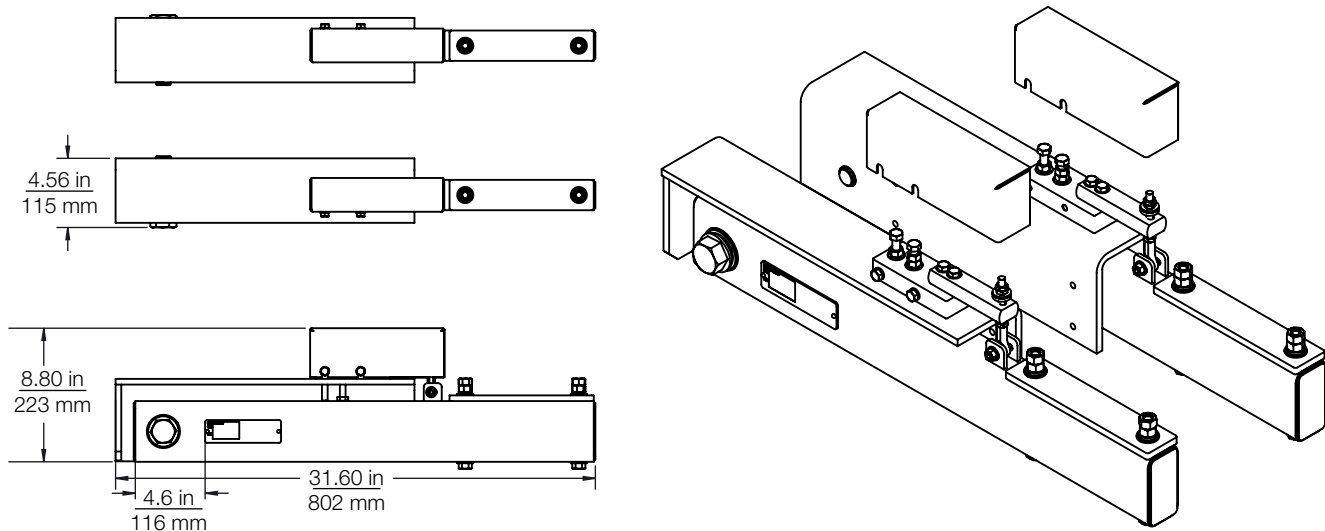

Figure 3-1. 221DB Dimensions and Assembly View

3.3 List of Parameters for belt scale

Complete the information below. Remove this page and store in a secure location.

CUSTOMER _____

ORDER NUMBER _____

INSTALLATION _____

REFERENCE _____

TYPE WEIGH FRAME _____

TYPE SPEED PICKUP _____

TYPE ELECTRONICS _____

DATE _____

FILLED IN BY _____

Parameter	Unit	Entered	Change
Nominal capacity (flow)	lb/hr (kg/hr)	_____	_____
Maximum capacity (flow)	lb/hr (kg/hr)	_____	_____
Minimum capacity (flow)	lb/hr (kg/hr)	_____	_____
Lever ratio (221DB weigh frame)		_____	_____
Number of load cells		_____	_____
Load cell capacity (per load cell)	lb (kg)	_____	_____
load cell sensitivity	mV/V	_____	_____
Idler spacing	in (mm)	_____	_____
Belt angle of incline	°	_____	_____
Belt speed	ft/s (m/s)	_____	_____
Speed pickup		_____	_____
Pulses per revolution		_____	_____
Non-driven drum	in (mm)	_____	_____
Total belt length	ft (m)	_____	_____

4.0 Appendix

4.1 Specifications

Weigh frame Material	Powder coated mild steel or Stainless Steel SS304 / 316
Weight	Approximately 104 lb (47 kg) not including the idler
Load Cells	2 single ended beam (stainless steel, IP66/IP68) Capacity 50 to 500 kg (each) Power supply 5-15 VDC (stabilized from electronics) Signal nominal 2 mV/V at 100% load

4.2 Total Load Cell Build Conversion

The 221DB Belt Scale has a lever ratio which must be applied to the total load cell build for proper calibration.

L = Load Distance

E = Effort Distance

Formula: $L / E = \text{Lever Ratio}$

Example: $23.62 / 17.65 = 1.33 \times 100 = 133\%$

This reconciles expected mV signal at the integrator with actual mV signal experienced at the effort point of the lever.

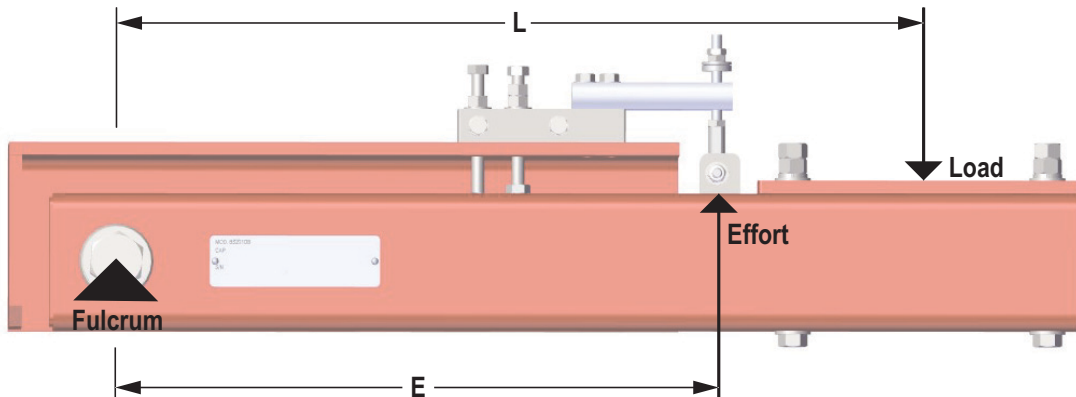

Figure 4-1. Belt Scale Lever Ratio

4.3 Overload Bolts

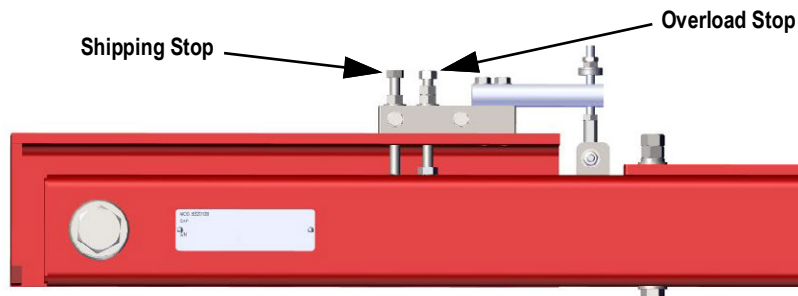

Figure 4-2. Overload Bolts

When the 221DB is shipped, the shipping/overload stops are set to prevent damage to the load cells. To set the stops for use, follow the procedure below after the scale has been installed and the integrator can have power applied.

1. Loosen the shipping stop to a 5mm gap between the end of the bolt and the scale arm.
2. Tighten the jam nuts to lock the bolt in position.
3. Remove the overload stop bolt.



© Rice Lake Weighing Systems Content subject to change without notice.

230 W. Coleman St. • Rice Lake, WI 54868 • USA USA: 800-472-6703 • International: +1-715-234-9171