

MSI-8000

RF Remote Display

Operation Manual



© Rice Lake Weighing Systems. All rights reserved.

Rice Lake Weighing Systems® is a registered trademark of
Rice Lake Weighing Systems.

All other brand or product names within this publication are trademarks or
registered trademarks of their respective companies.

All information contained within this publication is, to the best of our knowledge, complete and
accurate at the time of publication. Rice Lake Weighing Systems reserves the right to make
changes to the technology, features, specifications and design of the equipment without notice.

The most current version of this publication, software, firmware and all other product
updates can be found on our website:

www.ricelake.com

Revision History

This section tracks and describes manual revisions for awareness of major updates.

Revision	Date	Description
G	November 15, 2024	Revision history established;

Table i. Revision Letter History



Technical training seminars are available through Rice Lake Weighing Systems. Course descriptions and dates can be viewed at www.ricelake.com/training or obtained by calling 715-234-9171 and asking for the training department.

Contents

1.0	Introduction	7
1.1	Features	7
1.2	FCC Compliance	7
1.3	Safety	8
1.4	Disposal	9
1.5	Front Panel	10
2.0	Installation	11
2.1	Unpacking	11
2.2	Getting Started	11
2.3	Battery	11
2.3.1	Charging	11
2.3.2	Battery Longevity	12
3.0	Operation	13
3.1	Power	13
3.2	Zero	13
3.3	Tare	13
3.3.1	View Tare	13
3.3.2	Clear Tare	13
4.0	Setup	14
4.1	Setup Navigation	14
4.2	Setup Menu	14
4.3	Function Keys	15
4.3.1	Test	16
4.3.2	Total	16
4.3.3	Net/Gross	16
4.3.4	Peak Hold	17
4.3.5	Units	17
4.3.6	Hi-Res	17
4.3.7	Print	17
4.3.8	Total Remote Devices	17
4.4	Auto-Off	18
4.5	Setpoints	19
4.6	Output	20
4.7	Battery Life – Optional	20
4.8	Remote Scale Setup	21
4.8.1	Filter Setup	21
4.8.2	Total Mode	21
4.8.3	Standard	23



Rice Lake continually offers web-based video training on a growing selection of product-related topics at no cost. Visit www.ricelake.com/webinars

5.0 Calibration	24
5.1 Initial Calibration	24
5.2 Routine Calibration	25
5.3 C-Cal Calibration	26
5.4 Setup	27
5.4.1 Standard Settings	27
5.5 Reset the Load Cell Calibration	28
5.6 Auto Zero Maintenance (R _U L _E O ₀)	28
5.7 Zero Power Up (Z ₀ P - U ₀ P)	29
6.0 Communications	30
6.1 Communications Setup	30
6.2 Communications Menu	30
6.3 Printer Setup	31
6.3.1 Control Modes	31
6.3.2 Standard Print Strings	32
6.3.3 Printer Output Setup	33
6.3.4 Custom Print Formatters	34
6.3.5 Radio Setup	34
6.4 Setup Multiple Sensor Network	36
6.4.1 Set the Total Number of Load Cells	36
6.4.2 Scan Weight Inputs	37
6.4.3 Load Totaling Settings	37
6.5 Scan List ID	37
6.6 Zero and Tare in Multiple Load Cell Systems	38
6.7 Communications Port Hardware	38
6.8 Real Time Clock	40
7.0 Troubleshooting	41
7.1 Error Codes	42
7.2 Service Counters	42
7.3 Mechanical Dimensions	43
7.4 Firmware Update Procedure	43
7.5 Reset the Remote Control	44
7.6 Coin-Cell Battery Replacement	45
8.0 Specifications	47



Technical training seminars are available through Rice Lake Weighing Systems. Course descriptions and dates can be viewed at www.ricelake.com/training or obtained by calling 715-234-9171 and asking for the training department.



Rice Lake continually offers web-based video training on a growing selection of product-related topics at no cost. Visit www.ricelake.com/webinars

1.0 Introduction

This manual is intended for use by qualified technicians responsible for setting up and operating the MSI-8000 RF Remote Display.



Manuals are available from Rice Lake Weighing Systems at www.ricelake.com/manuals

Warranty information is available at www.ricelake.com/warranties

1.1 Features

- Rechargeable Lithium Polymer battery
- Automatic Power Off turns the unit off, after a user set time of no activity
- The enclosure is IP65 rated with shock cushioning on the corners
- Six, 1 in (25 mm) LCD digits
- Selectable for kg/lb/tons (US Short)/metric tons/kilonewtons
- Automatic or manual weight totalization
- Eight setpoints
- ScaleCore technology
- Optional hard-wired link

1.2 FCC Compliance

United States

This equipment has been tested and found to comply with the limits for a Class A digital device, pursuant to Part 15 of the FCC Rules. These limits are designed to provide reasonable protection against harmful interference when the equipment is operated in a commercial environment. This equipment generates, uses and can radiate radio frequency energy and, if not installed and used in accordance with the instruction manual, may cause harmful interference to radio communications. Operation of this equipment in a residential area is likely to cause harmful interference in which case the user will be required to correct the interference at his own expense.

Canada

This digital apparatus does not exceed the Class A limits for radio noise emissions from digital apparatus set out in the Radio Interference Regulations of the Canadian Department of Communications.

Le présent appareil numérique n'émet pas de bruits radioélectriques dépassant les limites applicables aux appareils numériques de la Class A prescrites dans le Règlement sur le brouillage radioélectrique édicté par le ministère des Communications du Canada.

1.3 Safety

Safety Definitions:



DANGER: Indicates an imminently hazardous situation that, if not avoided, will result in death or serious injury. Includes hazards that are exposed when guards are removed.



WARNING: Indicates a potentially hazardous situation that, if not avoided, could result in serious injury or death. Includes hazards that are exposed when guards are removed.



CAUTION: Indicates a potentially hazardous situation that, if not avoided, could result in minor or moderate injury.



IMPORTANT: Indicates information about procedures that, if not observed, could result in damage to equipment or corruption to and loss of data.

General Safety



Do not operate or work on this equipment unless this manual has been read and all instructions are understood. Failure to follow the instructions or heed the warnings could result in injury or death. Contact any Rice Lake Weighing Systems dealer for replacement manuals.



WARNING

Failure to heed could result in serious injury or death.

Do not allow minors (children) or inexperienced persons to operate this unit.

Do not stand near a load being lifted as it is a potential falling hazard. Keep a safe distance.

Do not use for purposes other than weight taking or dynamic load monitoring.

Do not use any load bearing component that is worn beyond five percent of the original dimension.

Do not use any associated lifting product if any of the load bearing components are cracked, deformed or show signs of fatigue.

Do not exceed the rated load limit of the associated scale/dynamometer unit, rigging element or the lifting structure.

Do not allow multi-point contact with the hook, shackle or lifting eye of the associated scale/dynamometer unit.

Do not allow high torque on the scale/dynamometer unless it is specifically designed for high torque.

Do not make alterations or modifications to the unit or associated load bearing devices; any alterations void the warranty.

Do not remove or obscure warning labels.

There are no user serviceable parts within the unit. Any repairs must be performed by qualified service personnel only.

For guidelines on safe rigging and loading of overhead scales and dynamometers, see www.ricelake.com/msi-landing-page/

Close proximity to audible alarm for sustained periods of time could be hazardous. Hearing protection may be required.

Do not use solvents or aggressive substances to clean the MSI-8000 RD.

Do not submerge.



IMPORTANT: All included batteries included intended for sale in the EU market are classified as "Portable Batteries for General Use" and comply with European Battery Regulation (EU) 2023/1542.

1.4 Disposal



Product Disposal

The product must be brought to appropriate separate waste collection centers at the end of its life cycle.

Proper separate collection to recycle the product helps prevent possible negative effects on the environment and to health, and promotes the recycling of the materials. Users who dispose of the product illegally shall face administrative sanctions as provided by law.

Battery Disposal

Dispose of batteries at appropriate waste collection centers at the end of their life cycle in accordance with local laws and regulations. Batteries and rechargeable batteries may contain harmful substances that should not be disposed of in household waste. Batteries may contain harmful substances including but not limited to: cadmium (Cd), lithium (Li), mercury (Hg) or lead (Pb). Users who dispose of batteries illegally shall face administrative sanctions as provided by law.



WARNING: Risk of fire and explosion. Do not burn, crush, disassemble or short-circuit lithium batteries.

1.5 Front Panel

The MSI-8000 RF Remote Display front panel, keys and annunciators are described below



Figure 1-1. Front Panel

Key Functions

Item No.	Key	Description
1		The F1 key; Programmable to user selectable functions (Section 4.3 on page 15); Default is Off ; Functions as the Enter/Select key when in the setup menus
2		The F2 key; Programmable to user selectable functions (Section 4.3 on page 15); Default is Off ; Functions as the Scroll key in the setup menus
3		The F3 key; Pre-programmed to Print and cannot be changed
4		The Power key; Powers the unit on and off; In Setup mode, it returns the display to the Weigh mode without storing changes
5		The Zero key; Zeros the residual load on a scale; In Setup mode, it stores changes and returns to the prior level
6		The Tare key; Removes current load value and puts the system into Net Weight mode

Table 1-1. Key Functions

Annunciator Functions

Item No.	Annunciator	Description
7	Center of Zero	Indicates that the scale is within 1/4 d of zero
8	Standstill	Indicates that the load has settled within the motion window (usually ± 1 d); When this is turned off, the scale will not zero, tare or totalize
9	LED Functions	Indicates the current displayed function <i>Example: If F1 blinks, the peak hold reading is captured. If F2 blinks, the Display and Function Test reading is captured.</i>
10	Total	Indicates the RF linked device is displaying the total accumulated weight; Displays only momentarily
	Peak	Indicates the RF linked device is in the Peak Hold mode
	Net	Indicates the RF linked device is in Net Load mode; A tare weight is subtracted from the gross load
	Metric Ton	In conjunction with the Ton annunciator, indicates the RF linked device is displaying metric tons
	Ton	Illuminated, indicates the RF Linked Device is displaying in U.S. Short Tons (1 ton = 2000 lb); When illuminated with M the RF Linked Device is displaying in metric tons (1 metric ton = 1000 kg)
	Kilonewtons	Indicates load display is in kilonewtons
	Kilograms	Indicates load display is in kilograms
	Pound	Indicates load display is in pounds
11	Setpoints	User programmable setpoints for overload warnings; Setpoints 1 and 2 are red high brightness LEDs
12	Multiple Sensors	Number lit indicates the sensor being displayed; If more than one number is lit, sensors are being summed <i>Example: If both numbers 1 and 2 are lit, then the weight displayed equals the sum of sensor 1 and sensor 2.</i>
13	Display Digits	Include six 1" (25 mm) sunlight visible LCD digits
14	Low Battery	Indicates about 10% of battery life remains; Symbol flashes when automatic shutdown is eminent

Table 1-2. Annunciator Functions

2.0 Installation

This section provides an overview of the MSI-8000 RF Remote Display installation instructions.

2.1 Unpacking

When unpacking the MSI-8000 RF Remote Display, ensure all parts are accounted for and check for any visible damage. If any parts were damaged in shipment, notify Rice Lake Weighing Systems and the shipper immediately. If the MSI-8000 RF Remote Display must be returned, it must be properly packed with sufficient packing materials. When possible, retain the original carton when shipping the unit back. A standard MSI-8000 RF Remote Display is shipped with a battery charger. The charger is universal and will work on AC supplies from 100 VAC–240 VAC.

2.2 Getting Started

Fully charge the battery by plugging the charger into the charge port. Depending on the discharge level of the battery this can take up to 6 hours.

The MSI-8000 RF Remote Display is often shipped pre-configured with a compatible sensor unit such as an Dyna-Link 2 or one of the MSI crane scales. If the MSI-8000 RF Remote Display is purchased separately, or is to be used with a different system, the RF transceivers will have to be paired ([Section 4.4 on page 18](#)).

Once RF setup is complete for the MSI-8000 RF Remote Display, the system will automatically connect with a scale/Dyna-Link. It is recommended to do a site survey to identify operating range and usability of the RF Link. Position the scale/Dyna-Link at an average operational height, and try the link at various positions and distances. The range may vary by the rotation of the scale/Dyna-Link, as well as the site and installation variables.

2.3 Battery

Power to the MSI-8000 RF Remote Display is supplied by an internal rechargeable lithium polymer battery, which provides up to 24 hours of continuous use between charging.



Figure 2-1. Battery Charger Plug-In

2.3.1 Charging

Each MSI-8000 RF Remote Display is shipped with a charged battery. However, before using the MSI-8000 RF Remote Display, it is advised to charge the battery until the green light shows it is fully charged. When **LOW BATT** first displays, there is approximately two hours of continued operation remaining. When **LOW BATT** starts flashing the batteries are nearly completely drained. For maximum battery life, it is recommended to recharge the battery as soon as **LOW BATT** displays. It is safe to charge the battery at any point in its discharge curve.

If the blue LED is on, the charger is in **Fast Charge** mode, which puts 80% of the charge into the battery within two hours and can be used at this point. However, it is best to fully charge the battery, until the green light displays.

The charge connector is waterproof when connected and screwed in. To maintain IP65 rating, use the supplied plug cover when the connector is not plugged in.



NOTE: The AC end of the charger is not waterproof.

Charger LED Modes

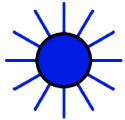

Blue light – Indicates a charge is in progress. Charging times vary from one hour to six hours depending on the charge level of the battery when the charger is applied. If the charger is attached as soon as **LOW BATT** displays, charge time will average three hours. It is OK to remove the battery charger while the blue light is on, but a complete charge is recommended.

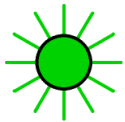

Green light – Indicates the battery is fully charged. The powered charger can be left connected to the MSI-8000 RF Remote Display continuously. It is recommended to leave the MSI-8000 RF Remote Display on the charger when not in use.

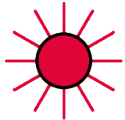

Red light – Indicates a fault. Faults include over temperature, under temperature (the battery must be warmer than 14°F (-10°C)), a severely depleted cell or charge time-out. When the charge times out a trickle charge is applied to the battery. To clear a time-out fault, unplug the charger and then plug it back in. A severely discharged cell may take days on the charger to recover.

2.3.2 Battery Longevity

The Lithium Polymer Single Cell Battery used in the MSI-8000 RF Remote Display has a rated number of charges of ≥ 300 before capacity starts to degrade. The charging life can be greatly increased by charging the battery more often, and not let it reach the battery cutoff voltage of 3.0 V. The battery voltage can be seen by pressing a function key programmed as **Test**, the battery must be replaced by an Rice Lake certified technician.



IMPORTANT: When the MSI-8000 RF Remote Display is not in use, it is recommended that the charger is left attached to keep a charge.

The MSI-8000 RF Remote Display uses a small current when powered off which has the potential to deep discharge the batteries. Never store the MSI-8000 RF Remote Display with a depleted battery. This can cause permanent damage to the battery and require factory replacement. Shelf life of a fully charged battery is about three months.

3.0 Operation

This section provides an overview of MSI-8000 RF Remote Display operation instructions.

 **NOTE:** Ensure the recommended battery or power supply is secured prior to device operation (Section 2.3 on page 11).

3.1 Power

Power the remote display On/Off by pressing .

3.2 Zero

Press  to take out small deviations in zero when the scale is unloaded. For zeroing (taring) package or pallet weights, see Section 3.3. The zero key can be used in **GROSS** or **NET** mode.

 **NOTE:** The backup memory in the unit stores the zero reading and retains it even if the power fails. Zeroing while in **NET** mode will zero the **GROSS** weight causing the display to show a negative tare value. The scale must be stable within the stable window.

The unit will only zero if  is on and there has been no activity for two seconds.



The scale will accept a zero setting over the full range of the scale (**NTEP** and other **Legal for Trade** models may have a limited zero range).

Zero settings above 4% of full scale will subtract from the overall capacity of the unit.

Example: If 100 lb on a 1,000 lb scale is zeroed, the overall capacity of the scale will reduce to 900 lb, plus the allowed over-range amount.



3.3 Tare

Tare is used to zero out a known weight, such as a packing container or pallet, and display a **NET** weight. The **TARE** function is defined as a **Tare-In** or **Tare-Out** operation. To tare the scale:

1. Hang the empty container from the scale.
2. Press  to enter a tare value. The MSI-3460C stores the current weight as a tare value and subtracts the value of the container from the **GROSS** weight.  displays and the weight mode changes to **NET**.
3. Add the product to the packing container. The **NET** weight is displayed.

3.3.1 View Tare

To view the **GROSS** weight without clearing the tare value:

1. Program  to the **NET/GROSS** function (Section 4.3 on page 15).
2. Press  to toggle between net and **GROSS** values. This will only work if a tare value has been established.

 **NOTE:** The backup memory in the MSI-8000 stores the Tare reading and can restore it even if power fails. Only positive **GROSS** weight readings can be tared. The **STABLE** annunciator must be on, indicating weight reading is stable. Setting or changing the tare has no effect on the **GROSS** zero setting. Taring will reduce the apparent over range of the scale. The **RF Remote Control** has **NET/GROSS** permanently available.

*Example: Taring a 100 lb container on a 1,000 lb scale, the scale will overload at a **NET** weight of 900 lb (1,000-100) plus any additional allowed overload (usually 4% or 9d).*

3.3.2 Clear Tare







To clear a saved tare value, press . The **GROSS** weight displays.

4.0 Setup



This section provides an overview of the MSI-8000 RF Remote Display setup instructions.

4.1 Setup Navigation

To navigate the menus during setup, follow the information below:

- Press  to enter or select a parameter
- Press  to scroll through the parameters
- To enter a decimal point, press  while the digit is blinking
- Press  to save and go back one level or to **Weigh** mode; *StorE* displays briefly
- If a wrong value is entered, press  to step back one digit and press  to change the digit
- Press  to exit without saving changes

4.2 Setup Menu

To enter the setup menu of the MSI-8000 RF, press  and  keys at the same time.



NOTE: The MSI-8000 RF Remote Display is also capable of performing certain setup functions remotely on the connected scale or DynaLink that it is receiving information from. See [Section 4.8 on page 21](#) for Remote Device Setup Menu.

Parameters	Choices	Description
Func 1 Func 2	-	Function Key 1 – Configurable to listed parameters (Section 4.3 on page 15); Default OFF
	-	Function Key 2 – Configurable to listed parameters (Section 4.3 on page 15); Default OFF
	OFF	No function is assigned; The F-key is disabled
	TEST	Test – Runs an LCD test (Section 4.3.1 on page 16)
	TOTAL	Total – Accumulates multiple weighments (Section 4.3.2 on page 16)
	u-TTL	View Total – Activates the total weight display followed by the number of samples (Section 4.3.2 on page 16)
	NETGR	Net/Gross – Toggles between Net and Gross modes (Section 4.3.3 on page 16)
	P-HLD	Peak Hold – Automatically updates display when a higher peak weight reading is established (Section 4.3.4 on page 17)
	2UNITS	2 Units – Switches the force units between lb and kg (Section 4.3.5 on page 17)
	5UNITS	5 Units – Scrolls through all available units: lb, kg, Tons (US Short), metric tons and kilonewtons (Section 4.3.5 on page 17)
	HIRE	Hi Res – The unit is more sensitive to motion and movement resulting in a less stable display (Section 4.3.6 on page 17)
	PRINT	Print – Outputs a configured text string to the RS-232 port on the base of the Dyna-Link (Section 4.3.7 on page 17)
	TARE	Tare – Not used, MSI-8000 RF Remote Display has a dedicated Tare key
	SCAN	Scan – Displays RF connected channels in order
TTLRD	Total Remote Devices – Displays the summed weight of RF connected sensors (Section 4.3.8 on page 17)	
A-OFF	OFF 15 30 45 60	Auto Off – Prolongs battery life of the scale by turning power off after the set time (in minutes) that the scale is not in use (Section 4.4 on page 18)
SETPointS SETPt 1-B	GREATER LESS OFF	Greater Than – Setpoint triggers when the tension exceeds the value Less Than – Setpoint triggers when the tension is less than the value Off - Setpoint parameter is disabled
battery	Standard Long	Battery Life – Sets the options for standard or extended battery life (Section 4.6 on page 20)

Table 4-1. Setup Menu Parameter Descriptions



Parameters	Choices	Description
StAnd	indUS Hb-44 r-76 Unit	Standards – Sets the industry standard to be used

Table 4-1. Setup Menu Parameter Descriptions (Continued)

4.3 Function Keys

There are two programmable function keys on the MSI-8000, **F1** and **F2**.







- Function key setup is independent of the connected scale/Dyna-Link function keys

-  and  are standard on the MSI-8000 and do not need to be programmed

- If a function key does not work, the connected RF transmitter may not be set up to support the key

Example: If the Function key is set for tOeRL, then tOeRL mode setup in the Setup Menu must also be set up for the target scale.

To set a function key use the following steps:

1. Press  and  at the same time, *FUnC 1* will display.
2. Press  to scroll to the function key to be programmed.
3. Press . The currently saved parameter will display.
4. Press  to scroll through the choices.
5. Press  to select the desired choice.
6. Press  to save and exit.





4.3.1 Test

The test feature only tests the MSI-8000. Set an **F-key** to **TEST**.

To run a test, press **Fx-TEST**, the following items scroll across the display.

- Light all LCD segments and the LEDs
- *S**o**F**t* followed by the version number
- *S**t**A**n**d* followed by the weighing standard
- *b**A**t**t* followed by the battery level in volts
- *d**A**t**e* followed by the date in “YY.MM.DD” format
- *t**i**m**e* followed by the time in 24 hr format
- *d*. *t**E**S**t* followed by a full display digit test

The test can be single stepped by:

1. Press **Fx-TEST**, immediately press  to stop the auto scroll.
2. Use  to scroll through the steps and  to view the step value.
3. Press  to abort the test at any time.

Internal tests are also performed, if any test fails, an error code is displayed. See [Section 7.1 on page 42](#) for a description of all error codes.

4.3.2 Total

1. Ensure the total mode has been programmed in the connected scale or dynalink setup menu. If this has not been setup the **F-Key** assigned to **Total** will not work.
2. Program an **F-key** to **Total** ([Section 4.3](#)).
3. Press **Fx-Total** to perform the total function that was set in [Section 4.8.2 on page 21](#).

4.3.3 Net/Gross

Program an **F-key** to **NetGross** ([Section 4.3 on page 15](#)).

Press **Fx-NetGross** to toggle between gross and net (gross minus tare). **Fx-NetGross** only functions if a tare has been established.

The operator can switch back to gross from net without clearing the tare value. Only clearing or setting a new tare will change the tare value held before switching into Gross Mode.

4.3.4 Peak Hold

Peak hold uses a high speed mode of the A/D converter allowing it to capture transient loads at a far higher rate than typical Dynameters.

- Peak Hold is cleared and enabled by pressing **Fx-P-HLd**
- When a new peak is detected, the **Fx** LED will flash three times
- The accuracy of the system in peak hold is slightly reduced to 0.2% of Capacity + 5 d
- The filter setting is turned off while in peak hold mode to ensure the fastest acquisition rate

Example: The Peak Hold function is useful in Dynamic and Fall tests. Common tests include Overall Breaking Strain (OB€), Breaking Force, and Cycled Breaking Strain.

Capture Peak Force:

1. Program an **F-key** to **P-HLd** (Section 4.3 on page 15).
2. Prepare the stand test and test sample.
3. Press .
4. Press **Fx-P-HLd**, confirm that **Pk** is lit on the display.



NOTE: A small jump in the reading occurs depending on the stability of the test device.

5. Apply the test weight. The **Fx** LED will blink three times when a new peak ID is detected
6. Remove the weight and the peak value is recorded.
7. To run a new test, press **Fx-P-HLd** to clear the peak value. Repeat [Step 3–Step 6](#).

4.3.5 Units

Program an **F-key** to **Unit** (Section 4.3 on page 15).

Press **Fx-Unit** to set the units parameter to units required for display.

4.3.6 Hi-Res



When set to on, the filter is automatically set to the **Hi-1** setting (if **Hi-2** is already set, then the filter is not changed). This will have a small effect on settling time. When set to off, the filter setting resets to the previous filter setting.

Program an **F-key** to **HiRes** (Section 4.3 on page 15).

Pressing **Fx-HiRes** places the display into a temporary high resolution mode. This mode continues until **Fx-HiRes** is pressed again, or power is cycled. In the Hi-Res mode the appropriate **Fx** LED blinks continuously at a slow rate.



NOTE: Hi-Res mode does not increase the accuracy, but allows for smaller weight incrementation to display.

Use  or  to zero out any initial error.

Hi-Res mode is not available when the weighing standard is set to a legal-for-trade standard such as HB-44 or R76

4.3.7 Print

The Print function is set to **F-3** key, so there is no need to program F1 or F2 to Print. Then pushing F1 or F2 on the scale will cause the Comm Port on the Remote to output the selected data string.

If an F-Key is programmed as Print and the Print Setup is configured as continuous, then the F3-Print key is used for Start Print/ Stop Print.

4.3.8 Total Remote Devices

Sensor summing must be enabled in the communications setup menu. If the **Pairs** or **Both** modes are enabled in the communications setup menu, then pressing **Fx-ttl.rd** will scroll through the available combinations.









NOTE: It is common to program F1 for SCAN and F2 for ttl.rd (Total Remote Devices) to allow quick switching between individual channel displays (with Scan) or the summed weight (with ttl.rd).

4.4 Auto-Off

The **Auto-Off** feature prolongs the battery life by powering off the unit when not in use. When a button is pressed or the detected load is in motion exceeding 10 d, the time limit is reset.

When disabled, the unit will only turn off by pressing  , or the battery dies.

To set the **Auto-Off** function:

1. Press and hold  and  . *FUNCTION* displays.
2. Press  to scroll to *Auto-Off*.
3. Press  . The current auto off time displays.
4. Press  to scroll through the available times.
5. Press  when the desired time is displayed. *SLEEP* displays.
6. Press  to exit setup and store the settings.

4.5 Setpoints

The MSI-8000 comes standard with two LED outputs for triggered setpoints. The triggering of setpoints 1 and 2 are indicated on the two setpoint relays.

 **NOTE:** Setpoints on both the MSI8000 remote display and the set points on the connected scale/DynaLink can be controlled and configured separately.

















The MSI-8000 has an audible output option that is triggered by Setpoint 1. Contact Rice Lake Weighing Systems for other setpoint output options.

 **NOTE:** The Menu supports 8 setpoints, but only 2 are available on the MSI-8000 Remote Display

Setpoint	Description
Setpoint Mode	
Off	Setpoint is not activated
GRE	Indicates the setpoint will trigger when the weight exceeds a set value
LESS	Indicates the setpoint will trigger when the weight is less than a set value
Setpoint Weight Type	
NETGr	responds to net or gross weight
GROSS	responds to gross weight regardless of the display
TOTAL	responds to the totaled weight
T-Cnt	responds to the total count (number of samples)
LFcnt	responds to the number of times the weight has exceeded 25% of capacity

Table 4-2. Available Setpoint Settings

To set the setpoint:

- Access setup menu of the remote device (Table 4-1 on page 14): Press and hold  and .
- Address setup menu of MSI-8000 remote display (Table 4-5 on page 23): Press and hold  and .
- Press  to scroll to the desired setpoint (STEP 1 - B).
- Press . The current setpoint mode is displayed.
- Press  to scroll to the setpoint mode desired.
- Press . The current setpoint weight type is displayed.
- Press  to scroll to the desired weight type.
- Press . The desired weight type continues to display.
- Press . $S_n I-4$ displays.
- Press  to toggle between $S_n I-4$ and $S_n 5$.
- With the desired setting displayed, press . The current weight type value is displayed.
- Press  to scroll the numbers and  to enter each digit.
- When the correct value is displayed, press . The next setup menu item is displays.

 **NOTE:** To enter a decimal point, press  while the digit is blinking. To correct a digit, press  to step back.





- Press  to exit setup and store the settings.

4.6 Output



Relay output allows the selection of Latch or Coil relays.

- Latch relays retain position even if the power fails
- Coil relays reset when power fails

 **IMPORTANT:** In the event of a power failure, the Latch relay uses continuous battery power and will deplete the battery more quickly than the coil relay.

- Press and hold  and . **FUNC 1** displays.
- Press  to scroll to the **OUTPUT**.
- Press . The current setting is displayed.
- Press  to toggle between **COIL** and **LATCH**.

 **NOTE:** The display brightness changes when each setting is displayed.







- Press  when the desired setting is displayed. **B.L.I.F.E** displays.
- Press  to exit setup and store the settings.

4.7 Battery Life – Optional

Select either Standard (**Stand**) or Long (**Long**).

In Long battery life mode, the system is placed into a sleep state for several seconds at a time if there is no change in tension. This disables the display in order to reduce power consumption and increase battery life. After several seconds, the MSI-8000 will wake up to check for any changes in tension. If there is a change in tension, the unit will stay awake. The unit will also stay awake if it is in configuration mode.

Although long battery life mode can significantly increase battery life, performance is better in Standard battery life mode.

- Press  and  simultaneously. **FUNC 1** displays.
- Press  to scroll to **B.L.I.F.E**.
- Press . The currently saved battery life displays.
- Press  to toggle between the choices.
- With choice displayed, press  to select. **Stand** displays.
- Press  to save and exit to weighing mode.

4.8 Remote Scale Setup

The MSI-8000 RF Remote Display can be used to operate any RF capable ScaleCore based crane scale. Some functions can also be set using the MSI-8000. The information in this section pertains to the setup of the scale being used with the remote.

To enter the setup menu of the configured remote device, press  and  keys at the same time.







Parameters	Choices	Description
Filter	OFF	Weight Filter – allows the scale to adjust to situations where there may be movement See Section 4.8.1
	LO	
	Hi - 1	Hi-2 – MSI-7300 only
	Hi - 2	
Total	OFF	Total Accumulation - sets the choice for weight accumulation for a single scale (Section 4.3.2 on page 16); When set to off, it's disabled
	TTOn	Total On - Is a manual choice for accumulation (Section 4.3.2 on page 16)
	A. Load	Auto Total - Choices for setting automatic accumulations
	A. Last	
	H. High	
SetPt 1-8	Greater	Greater Than – Setpoint triggers when the tension exceeds the value (Section 4.5 on page 19)
	Less	Less Than – Setpoint triggers when the tension is less than the value (Section 4.5 on page 19)
	OFF	Off - The setpoint parameter is disabled (Section 4.5 on page 19)
Battery Life	Standard	Battery Life –Sets the options for standard or extended battery life; See Section 4.6 on page 20
	Long	

Table 4-3. Settings for the Scale using the Remote

4.8.1 Filter Setup

The filter settings are used to stabilize the weight in an unstable condition. Increasing the filter will improve the stability, however settling times will be longer. The MSI-8000 employs algorithms that speed up large weight changes while still controlling vibration even with high filter settings.

Use the following steps to set up filtering.

1. Press  and  simultaneously. *Func 1* displays.
2. Press  to scroll to *Filter*.
3. Press . The currently saved total mode displays.
4. Press  to scroll through the choices.
5. With choice displayed, press  to select. *Unit* displays.
6. Press  to save and exit to weighing mode.

4.8.2 Total Mode

For the accumulation of multiple weighments, the Total function uses the displayed load, so gross and net readings can be added into the same total.

There are four modes of totalizing, a manual and three auto modes.



All modes require that the weight on the scale return below 0.5% (relative to full scale) of **Gross Zero** or **Net Zero** before the next weighment can be added. Applied weight must be $\geq 1\%$ of full scale above **Gross Zero** or **Net Zero** before it can be totaled.

Manual Total

Manual Total (Total) adds a current weight to a previously accumulated value manually. To add weight to the total it must be greater than 1% of capacity and not yet totaled. This assures that a weight on the scale is only added to the total once.

1. Program a **F-key** to Total (Section 4.3 on page 15).
2. With the weight to be added on the scale, press **F-Total**. The acknowledge LED blinks to indicate the weight was accepted and the **TOTAL** annunciator lights. Then the total weight is displayed for five seconds and the number of samples is displayed for two seconds.
3. Repeat Step 1 and Step 2 until all weight samples have been added.



NOTE: Total Mode will not function while the scale is in motion, ensure   is on. If the system fails to achieve stable readings, increase the filter setting or increase the size of the scale division (d) in the Init Cal procedure.

The F-Total functions as View Total only until the 1% threshold is exceeded to allow the addition to the total value.

Auto Total







This mode has three variations which are programmed in the Setup menu.

Program an **F-key** to **AUTO TOTAL**, it functions as **Auto Total On / Auto Total Off** (Section 4.3 on page 15).

Setpoint	Description
R. Load	Auto Load – Ensures any settled load above the Rise Above threshold will be automatically totaled; The scale must fall below the Drop Below threshold before the next total is allowed
R. Last	Auto Last – Takes the last settled weight to auto total with; The total occurs only once the scale goes below the threshold; This allows the load to be adjusted without a total occurring; Once the load is removed, the scale uses the last settled reading for total
R. High	Auto High – Uses the highest settled reading; This is useful for loads that can not be removed all at once

Table 4-4. Auto Load Selections

Set Total Mode

1. Press  and  simultaneously. FUNC 1 displays.
2. Press  to scroll to Total.
3. Press . The currently saved filter mode displays.
4. Press  to scroll through the choices.
5. With choice displayed, press  to select. FILTER displays.
6. Press  to exit setup and store the settings.

Reset Total Load

To reset the total load to zero, press **Fx-Total** again and while the total load is being displayed, quickly press .







4.8.3 Standard

The MSI-8000 Remote Display does not have its own standard. Scale Legal-for-trade settings can be accessed from the MSI-8000 RF Remote display, but legal-for-trade configuration must be set up in the scale. Refer to the scale specific manual for legal for trade setup.

Selection	Description
Industrial (INDUS)	This is the most common setting for the MSI-8000; With the Industrial standard, there is full range zero, access to units switching, filters, and peak hold
Handbook 44 (HB-44)	Enables only approved features per the NTEP HB-44 rules and regulations; Access is denied to Peak Hold, and the zero range may be limited; The Filter menu is moved to the calibration setup menu, so filters are only accessible through the calibration seal; Can only be changed if calibration button has been pressed
R-76 (R-76)	Sets the scale to enable only approved features per OIML R-76; Only kg weight units are available; The zero range is limited to 4% (-1 to +3% relative to calibrate zero); Net/Gross function is temporary; Once net weight is established, pushing an F key set for Net/Gross will cause a maximum 5 second display of the gross weight. Clear the Tare to display gross weight constantly; Other metrological aspects are changed to meet R-76 requirements; Can only be changed if calibration button has been pressed
1Unit (1UNIT)	The 1unit standard is exactly the same as Industrial, except units switching is inhibited; Used for metric only countries or where 1Unit standard is to allow the scale to be calibrated in units other than lb or kg, since conversions are eliminated; Contact Rice Lake for more information on the standards settings

Table 4-5. Standard Menu Selections

Use the following steps to set up standard settings.

1. Press  and  simultaneously. *FUNC 1* displays.
2. Press  to scroll to *Stand*.
3. Press . The currently saved standard displays.
4. Press  to scroll through the choices.
5. With choice displayed, press  to select. *FUNC 1* displays.

Press  to save and exit to weighing mode.

5.0 Calibration

This section provides an overview of MSI-8000HD RF Remote Display calibration instructions.

The MSI-8000HD RF Remote Display can be used for calibrating MSI ScaleCore-based scales, dynamometers, and other RF transmitting devices.

They can be calibrated using standard precision test weights. It is required that the weight used is at least 10% of full capacity in order to achieve rated accuracy.

When adequate test weights are not available, the scale/dynamometer can be calibrated using a constant calibration (C - CRL) (Section 5.3 on page 26).

















NOTE: Any connected weighing device that is set for a legal-for-trade mode cannot be calibrated remotely without first pressing the physical calibration button on the device being calibrated.

5.1 Initial Calibration















Initial calibration is used to setup units, capacity and resolution (d) required for the load cell.

Initial calibration is also performed after a calibration reset which deletes all calibration.

1. Press  and  simultaneously. CRL displays.
2. Press the programmed F-key to scroll to the load cell to be calibrated.
3. Press , Unit displays.
4. Press . The default units are displayed.
5. Press  to scroll through the available units.
6. With desired unit displayed, press  to select. CAP displays.
7. Press . The default capacity displays.
8. To enter a different capacity, press .
9. Press  to scroll through numbers and  to save the selected numbers.
10. When all numbers have been selected, press  to store the number. d displays.
11. Press . The default display divisions are displayed.
12. Press  to scroll through the available display divisions.
13. With desired display division displayed, press  to select. UNLD displays.
14. Proceed with the routine calibration, starting with Step 2 of Section 5.2 on page 25.

5.2 Routine Calibration

For maintenance and routine calibration use the following steps.





1. Press the configuration switch on the scale. $\bar{C}RL$ displays.
2. Press , $UnLd$ displays.
3. Remove all weight from the scale.
4. Press , $\bar{0}$ flashes.
5. Press , $PASS$ displays momentarily then $Ld1$ displays.
6. Load the scale with a precision test weight, for best accuracy a test weight of 10% of capacity or more is recommended.
7. Press , the capacity of the scale flashes.
8. To enter a test weight other than the capacity, press .
9. Press  to scroll through numbers and  to save the selected numbers.
10. When the correct weight displays, press  to store the number. If cal value is within limits, $PASS$ displays momentarily then $Ld2$ displays.
11. Press  to enter the second load.
12. Add load to scale and press .
13. Press , the current weight on the scale flashes.
14. Repeat [Step 3–Step 10](#), up to four loads.
15. When all loads are complete, press  to store the calibrations. $\bar{C}RL'd$ displays.
16. Press , to view the cal number. $\bar{C}-\bar{C}RL$ flashes momentarily followed by the $\bar{C}-\bar{C}RL$ number, record the value, this number will be required if calibrating with $\bar{C}-\bar{C}RL$ ([Section 5.3 on page 26](#)).
17. Press . $StorE$ displays momentarily, then $SEtUP$ displays.
18. Press  to exit **Calibration**. $StorE$ displays momentarily, then the unit returns to **Weigh** mode.

Repeat this procedure to calibrate all load cells connected to the MSI-8000 RF Remote Display.





5.3 C-Cal Calibration

When adequate test weights are not available, the scale can be calibrated using a cal number calibration which is referred to as C-Cal. To use C-Cal, a factory generated C-Cal number must be known. Rice Lake supplies replacement load cells with the C-Cal value stamped on the serial number label. When a calibration is performed with test weights, a new C-Cal is generated.

The C-Cal number must be known prior to starting this procedure. C-Cal reduces slightly the accuracy of the system and is intended for non-critical use only. For highest accuracy, calibrate with precision test weights.













1. Press the configuration switch. $\bar{C}AL$ displays.
2. Press  to scroll to $\bar{C}-\bar{C}AL$.
3. Press , $UNLd$ displays.
4. Remove all weight from the scale.
5. Press , \bar{C} flashes and $PASS$ displays momentarily. $\bar{C}-\bar{C}AL$ displays.
6. Press , the last known $\bar{C}-\bar{C}AL$ displays.
7. To except the number displayed press . Skip to [Step 10](#).

To enter a different $\bar{C}-\bar{C}AL$ number, press .

8. Press  to scroll through numbers and  to save the selected numbers.
9. When the correct number displays, press  to store the number. $PASS$ displays momentarily then $\bar{C}AL'd$.
10. Press . $StorE$ displays momentarily then $SEtUP$ displays.
11. Press  to exit calibration. $StorE$ displays momentarily, then the unit returns to **Weigh** mode.

5.4 Setup

Setup is used to set the desired Industry Standard and Auto Zero Maintenance (AZM).

1. Press the configuration switch (Section 5.1 on page 24). *cRL* displays.
2. Press  to scroll to *SEtUP*.
3. Press , *StAnd* displays.
4. Press , the current standard setting displays.
5. Press  to scroll through calibration standards selections. See Section 5.4.1 on page 27 for standards details.
6. When desired option displays press . *Auto* displays.
7. Press  to enter Auto Zero Maintenance.
8. Press  to toggle between *On/Off*.
9. Press  to set on or off. *0. P-UP* displays.
10. Press  to enter zero on power-up.
11. Press  to toggle between *On/Off*.
12. Press  to set on or off. *StAnd* displays.
13. Press  to return to *cRL*.
14. Press  again to exit calibration. *StorE* displays momentarily, then the unit returns to **Weigh** mode.

5.4.1 Standard Settings

Below are the four selections in the standards menu.



Standard Type	Description
Industrial <i>IndUS</i>	The common setting for the MSI-8000 RF Remote Display; With the Industrial standard, you have full range zero, access to units switching, filters, and peak hold
Handbook 44 HB44	Sets the scale to enable only approved features per the NTEP HB-44 rules and regulations; Access is denied to Peak Hold, and the zero range may be limited; The Filter menu is moved to the Cal Setup Menu, so filters are only accessible through the Cal Seal
R-76 <i>r-76</i>	Sets the scale to enable only approved features per OIML R-76; Only kg weight units are available; The zero range is limited to 4% (-1 to +3% relative to calibrate zero); Net/Gross function is temporary; Once net weight is established, pushing an F key set for Net/Gross will cause a maximum 5 second display of the gross weight; Clear the Tare to display gross weight constantly; Other metrological aspects are changed to meet R-76 requirements; Only stable weights may be printed; Negative weight display is limited to -20d
One Unit <i>Unit</i>	The one unit standard is exactly the same as Industrial, except unit switching is inhibited; This is useful for Metric only countries; Another use of the One Unit standard is to allow the scale to be calibrated in units other than lb or kg, since conversions are eliminated

Table 5-1. Standard Settings Parameter

Contact Rice Lake Weighing Systems for more information on the standards settings.

5.5 Reset the Load Cell Calibration

To completely remove current calibration, a calibration reset must be performed.

1. Press the **F-key** set to scan to scroll to load cell to reset.
2. Power down the unit
3. Press and hold the calibration switch, then press . **RESET** flashes.**ss**
4. Press , **SURE** flashes.
5. Press  to reset the calibration for current load cell. **CRL** displays.
6. Proceed with the Initial Calibration ([Section 5.1 on page 24](#)).

 **IMPORTANT:** Pressing  to reset all indicator settings to the original factory settings.

 **NOTE:** Press  to cancel reset and return to the previous menu.







5.6 Auto Zero Maintenance (AZM)

An auto zeroing maintenance mechanism is used to adjust the zero reading to the center-of-zero. The center-of-zero is defined as the weight reading within 1/4 d of zero. AZM continuously adjusts zero to maintain the center-of-zero. It is recommended that AZM is on to maintain the highest accuracy.

There are circumstances when it should be turned off. This can happen when minor variations of weight occur while picking up scale attachments and the variations fall within the AZM capture window. The AZM capture window (usually 1 d) and capture time (usually 8 seconds) can be adjusted by Rice Lake Weighing Systems to meet custom requirements.







The settings of AZM are dictated in Legal for Trade standards and cannot be adjusted.

Use the following steps to set up Legal for Trade standard settings.

1. Enter **Configuration** mode ([Section 5.1 on page 24](#)). **CRL** displays.
2. Press  to scroll to **SETUP**.
3. Press . **Start** displays.
4. Press  to scroll to **AZM**.
5. Press . The current setting is displayed.
6. Press  to toggle between **On** or **OFF**.
7. Press . **Done** displays.
8. Press  twice to save settings. **STORE** displays briefly and exits setup.

5.7 Zero Power Up (Z.P-UP)

This feature will cause the unit to automatically zero after the unit is turned on. Default is OFF.

1. Enter **Configuration** mode ([Section 5.1 on page 24](#)). *CAL* displays.
2. Press  to scroll to *SETUP*.
3. Press . *Stand* displays.
4. Press  to scroll to *Z.P-UP*.
5. Press . The current setting is displayed.
6. Press  to toggle between *On* or *OFF*.
7. When desired value is displayed, press . *ENTER* displays.
8. Press  twice to save settings. *STORE* displays briefly and exits setup.

6.0 Communications

This section provides an overview of the MSI-8000 RF Remote Display communication instructions.

6.1 Communications Setup

The 802.15.4 transceiver is used to communicate between the MSI-8000HD and other connected ScaleCore devices. The 802.15.4 transceiver is also capable of connecting to any supported device with an 802.15.4 Modem. 802.15.4 operates in the 2.4 GHz ISM band and does not require the end user to obtain a license. 802.15.4 can coexist with other 2.4 GHz systems if caution is taken to isolate antennas at least 10' (3 m) from the crane scales.

The 802.11 Wi-Fi option communicates directly with a standard RF access point. This option is covered by the Wi-Fi for ScaleCore User Guide."

Name	Description	Recommended Number Range
ScaleCore ID	Used to identify each device in a piconet, its range is 0–254 and cannot be duplicated within the same RF channel	20–30
RF Channel	Establishes the base network that all interconnected devices must match	12–23
Network ID	A 64-bit number that all interconnected devices must match, do not use a small number to avoid other 802.15.4 transceivers that default to a network ID of 0	Maximum of six digits with a range of 0–65535

NOTE: For all devices that must interconnect, the RF channel and network ID must match. The ScaleCore ID must be unique. The Dyna-Link or crane scale that is the weight source should be set to a ScaleCore ID of 0. If other source devices are added, they can be added in sequence.

NOTE: It is possible to have multiple separate MSI ScaleCore RF networks in the same location. Each device on the same network must be on the same channel, but for best performance different ScaleCore networks should be on different RF channels.

Table 6-1. Piconet Setup Ranges

6.2 Communications Menu

To enter the Communications menu, press  and  at the same time. *bL5Y* flashes momentarily before entering the communications menu.

Parameters	Choices	Description
Print	--	Print – Prints a ticket if connected to a printer
rF	--	Radio Frequency (Section 6.3.5 on page 34)
CF.nEt	tP.o.r.d	Load Totaling – The total number of Remote Sensor Devices (RD's) – Range 1–4 (Default is 1)
	tEtL.r.d	Total Remote Displays All – Sum of all remote devices Prirs – Sum in pairs (requires four remotes) both – Sum in pairs plus grand total vsedef – Programmed using a computer program such as Scope off – Summing is disabled
	Li.Ste.d	–
	SE.nLS	SE.i.d SE.n.d
rEtC	YEAR Month dAY hour Minute	Date/Time – Set date and time for printing output (Section 6.8 on page 40)

Table 6-2. Communications Menu Parameters

6.3 Printer Setup

The RS-232 communications port is capable of outputting load data. All of the RF linked weight device weight modes are available in user formatted form. The control mode program is what controls the MSI-8000HD to print and is described in [Section 6.3.1](#).

The communications port settings are independent of any print settings in connected scales.

Choices	Description
LS _{ET} NR	Print Setup – Select the channel the port will be used with; Options: 0, 1, 2
OUT _{PUT}	Port Selection – Select the port to use for communication with the printer; Options <i>Port 0</i> , <i>RF</i> , <i>Port 2</i>
STR _{NG}	String Setup – Print string format number entry screen (Section 6.3.3 on page 33)
EN _{TER} L	Print Control Options – <i>USER</i> , <i>LOAD</i> , <i>CONT</i> , <i>OFF</i> (Table 6-4)
RA _{TE}	Output Rate – Print string output rate number entry screen (0–65536 seconds)

Table 6-3. Print Setup Parameters

6.3.1 Control Modes

The user can select four control modes.

Mode	Description
User	Printing is controlled by pressing the F3 key
Load	One print occurs when a stable load is read, the scale must then return to near zero before another print will occur NOTE: Other configurations of load are available using ScaleCore Connect. It can be downloaded from the Rice Lake Website.
Continuous	The unit will continuously output the data at a rate specified in the rate parameter (up to 65,535 seconds); Setting the interval to 0 will set an interval as fast as the system can go
Off	Printing is disabled; Power consumption is lower with the print off

Table 6-4. Control Modes

6.3.2 Standard Print Strings

Commands that can be used to format gross, net and print strings are shown below.

Command	Description
<T>	Load data
<U>	Units
<M>	Load mode (lb/kg)
<CRLF>	Carriage return line feed
<SP>	Space
<STX>	Start of text character (ASCII 2)
<P>	Space for positive, - for negative
<W7.>	7-digit weight, floating decimal, leading spaces
<S>	Status, upper case: <SP> =OK, M=Motion, O=Overload, Z=Zero, I=Invalid

Table 6-5. Standard Print Strings

Print String Number	Parameter	Description
1	Current load	Fixed output length: 16; Leading zeros suppressed except for the least significant digit (LSD) <TTTTTT><SP><UU><SP><MMMMM><CRLF>
2	Net load	Fixed output length:16; Leading zeros suppressed except for the LSD <TTTTTT><SP><UU><SP>NET<SP><SP><CRLF>
3	Gross load	Fixed output length: 16; Leading zeros suppressed except for the LSD <TTTTTT><SP><UU><SP>GROSS<CRLF>
4	Tare Weight	Fixed output length: 16; Leading zeros suppressed except for the LSD <TTTTTT><SP><UU><SP>TARE<CRLF>
5	Total Weight	Fixed output length: 16; Leading zeros suppressed except for the LSD <TTTTTT><SP><UU><SP>TTL<CRLF>
6	Number of Samples Totaled	Fixed output length: 16; Leading zeros suppressed except for the LSD <SP><SP><SP><SP><SP><SP><SSSSSS><SP><T-CNT><SP><CRLF>
7	Rice Lake / Condec:	Stream Data Format <STX><P><W7.><U><M><S><CR><LF>
8/9	Carriage Return/Line Feed	Used to add a space between print records <CRLF>

Table 6-6. Standard Print Strings













NOTE: If unit is in legal for trade mode (r76-HB44) the only print string available is number 1.

Combinations of the standard print strings can be entered in the string number entry screen.

Example: To get a Net, Gross, Tare printout with a space between records, enter 2349.













6.3.3 Printer Output Setup

Use the following steps to set up the printer output.

1. Press  and  at the same time. *Print* displays.
2. Press . *Listnr* displays.
3. Press  to scroll to *Strnc*.
4. Press . The current print string number is blinking.
5. Press  to scroll through the numbers and press  to save and move to the next number.
Example: If Net, Gross and Tare are to be used for the print format, the entry required would be 2349. The 2 is net, 3 is Gross, 4 is tare and 9 inserts a space before the next print output.
6. Once all numbers are set, press  to save the **Print** mode. *Print* displays.
7. Press . The current **Control** mode displays.
8. Press  to scroll through the options.
9. When the desired **Control** mode displays, press . *Rate* displays.



NOTE: If Control mode has been set to continuous, press  then skip to [Step 13](#).

10. Press . The current print rate displays.
11. Press  to scroll through the numbers and press  to save and move to the next number.
12. When number is correct, press . *Listnr* displays.
13. Press . The current listener value displays.
14. Press  to scroll through the numbers and press  to save and move to the next number.
15. Once the desired value displays, press  to save. *Output* displays.
16. Press . The current output displays.
17. Press  to scroll through the options.
18. Once the desired output displays, press  to save. *Strnc* displays.
19. Press  three times to exit, *StorE* displays briefly, then the unit returns to **Weigh** mode.

6.3.4 Custom Print Formatters

The ScaleCore Connect application is used to create custom output formatters. Download the ScaleCore Connect software from the Rice Lake website. For more information see the ScaleCore Connect software manual (PN 185725).

Custom formatters are also configured in the ScaleCore Webserver. For more information, see the ScaleCore Webserver technical manual (PN 208738).

The serial output is configured as 9600 baud, Xon/Xoff handshaking, no hardware handshaking, 1 stop bit, no parity.

Other baud rates are possible by special order only.

6.3.5 Radio Setup

Allows the setup of the Radio.

Mode	Description
on.off	Enable radio – On/Off, affects continuous mode only
SCid	ScaleCore ID – Range 1–254, (20–30)
Chnl	RF Channel – Range 12–23
netid	Network ID – Range 0–999999
StrEn	Transmission Strength – Range 0–4 (Table 6-8)
TYPE	Allows the selection of radio card that is being used; For cards other than XBee/802.15.4 use the other selection: DthEr, 2bEE
hold	When set to On, the radio continues to use power; This will use the battery power faster; Default is set to OFF; Hold must be enabled when using a Rugged Remote to turn on the MSI-8000HD

Table 6-7. RF Setup Parameters











NOTE: Transmission strength should be set to the lowest setting possible to achieve the transmission required. Both scale/Dyna-Link and MSI-8000 RF Remote Display should be set at the same transmission strength setting.

Setting	RF Power Level	Transmit Current	Note
0	10 dBm	137 mA	Lowest Transmission Power
1	12 dBm	155 mA	Default on 7300s and 8000s
2	14 dBm	170 mA	–
3	16 dBm	188 mA	–
4	18 dBm	215 mA	–

Table 6-8. Transmission Strength Settings













Use the following steps to set up the RF menu parameters.

- Press **F1** and **F3** at the same time, **PRINT** displays.
- Press **F2** to scroll to **RF**.
- Press **F1**. **on.off** displays.
- Press **F1**. The currently saved parameter is displayed.
- Press **F2** to toggle between on and off.
- With **on** displayed, press **F1** to select. **off** is used when the 8000 is hardwired to a Dyna-Link. **SCid** displays.
- Press **F1**. The current ScaleCore ID displays.
- Press **F2** to scroll through numbers and **F1** to save the selected numbers.

9. When number is correct, press  to store the number. `CHNL` displays.
10. Press . The current channel setting displays.
11. Press  to scroll through numbers and  to save the selected numbers.
12. When number is correct, press  to store the number. `NETID` displays.
13. Press . The current Network ID displays.
14. Press  to scroll through numbers and  to save the selected numbers.



NOTE: Rice Lake Weighing Systems recommends at least a four digit for the Network ID, to ensure there are no conflicts with any other 802.15.4 networks.

15. When number is correct, press  to store the number. `STREN` displays.
16. Press . The current Strength setting displays.
17. Press  to scroll through 0–4.
18. When the number is correct, press . `TYPE` is displayed.
19. Press . The current type displays.
20. Press  to scroll through values.
21. With selected value displayed, press . `hold` displays.
22. Press . The current setting displays.
23. Press  to toggle between on and off.
24. When the selection is correct, press  to store the number. `ONOFF` displays.
25. Press  to save and exit the RF menu.
26. Press  to exit to the communication menu.

6.4 Setup Multiple Sensor Network

The MSI-8000 RF Remote Display can monitor up to four load sensors. The sensors can be read individually, in pairs or summed. Dyna-Link 2 is shown for illustration purposes only. The Challenger 3 or Port-A-Weigh can also be used.

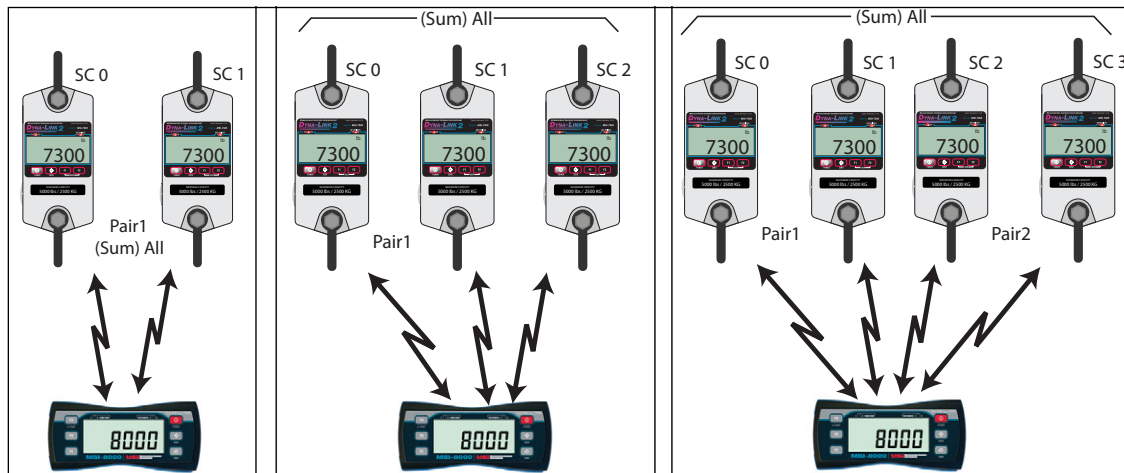

Figure 6-1. Multiple Sensor Network

Each sensor has a unique ScaleCore ID (SCID). The IDs must be consecutive, starting with 0. This is set in the sensor setup, not in the MSI-8000 RF Remote Display. See the Dyna-Link 2 Technical Manual (PN 152160).

6.4.1 Set the Total Number of Load Cells

1. Press **F1** and **F3** at the same time. *Print* displays.
2. Press **F2** to scroll to *CF. nEt*.
3. Press **F1** *tFla. Ld* displays.
4. Press **F1**. The **Load Totaling** setting displays.
5. Press **F2** to scroll through numbers and **F1** to save the selected numbers.
6. When correct number of scales/Dyna-Link 2 attached (2-4) displays, press **F1**. This number does not include the MSI-8000 RF Remote Display or any modems. *tLl. rd* displays.
7. Press **F1**. The **Load Totaling** setting displays.
8. Press **F2** to scroll through numbers and **F1** to save the selected numbers.
9. Press **F1**. *tNard* displays.
10. Press **ZERO** twice to exit to the **Weighing** mode.

6.4.2 Scan Weight Inputs

1. Program **F1** to the *Scan* function, and **F2** to the *Add.Ld* function for summed sensor readings (Section 6.4.3).
2. The current channel displays, press **F1** to change to the next channel. The scan channel number displays briefly, then the scan channel weight displays.
3. Press **F1**. In a two sensor system the scan returns to the first channel (0).

6.4.3 Load Totaling Settings

There are four different types of load totaling modes and are explained below.

All

All channels are added together, press **Fx-Add.Ld** to view the sum of all sensors connected. Pressing **Fx-Add.Ld** again confirms that the summed channels are being displayed, by briefly displaying *Add.Ld* (total remote sensor devices).



NOTE: If the sum is the only thing to be observed, disable the Scan function key using the Function Key Setup menu (Section 4.3 on page 15).

Pairs

Used with four sensor systems, scrolling through the channels with **Fx-Add.Ld**, they will be presented as separate weights first and then as pairs. This display is preceded by the LCD message *Pair 1* and *Pair 2*.

Both

This mode displays both the pair totals and the overall total. Each press of **Fx-Add.Ld** scrolls through the summed combinations. First *Pair 1*, then *Pair 2* then the sum of all connected sensors displays.

Off

Sensor summing disabled. A function key set to *ttl.rd* is unnecessary.

1. Program an **F-key** to the *ttl.rd* function (Section 4.3 on page 15). The current channel displays.
2. Press **Fx-ttl.rd**. *Ad.All* displays briefly, then the summed total.
3. Continue pressing **Fx-ttl.rd** to view all enabled sum types.

6.5 Scan List ID

The scan list ID specifies the load cell/sensor that scale one through four will use for summing totals. It allows up to four devices to be summed together on the remote display.

1. Press **F1** and **F3** at the same time. *Print* displays.
2. Press **F2** to scroll to *ScanLS*.
3. Press **F1**. *List id* displays.
4. Press **F1**. Current *List id* flashes.
5. Set the ID number of the LC/Sensor that will be assigned to Scale.1 (0-3 are used to represent 1-4. For example, 0=1, 1=2, 2=3, 3=4).
6. Press **F1** to store the number. *Scale id* displays.
7. Press **F1**. The scale ID must match the ID of the LC/Sensor being connected to.
8. Press **F1** to store the number. *Scale id* displays.
9. Press **F1**, The sensor number is used to select a LC connect to the Scale being addressed in *List id*.

10. Press **F1** to store the number. *LC 15.1* displays.

11. Press **ZERO** twice to exit to the **Weighing** mode.

The sum will now reflect the total of all LC/Sensors specified.

6.6 Zero and Tare in Multiple Load Cell Systems

The channel displayed is considered the **Focus Channel**. Pressing **ZERO** or **TARE** only affects the displayed channel.

When displaying summed channels, ZERO or TARE commands are sent to all devices that contribute to the displayed weight.

Example: If in the Both modes, and displaying pair 1 (sum of SC0 and SC1), pressing ZERO will zero only SC0 and SC1. If displaying the grand total using the ALL mode then pressing ZERO will zero all connected sensors.

6.7 Communications Port Hardware

The MSI-8000 RF Remote Display RS-232 communication port is used for software updates, connecting to a remote display and for connecting to any RS-232 device.

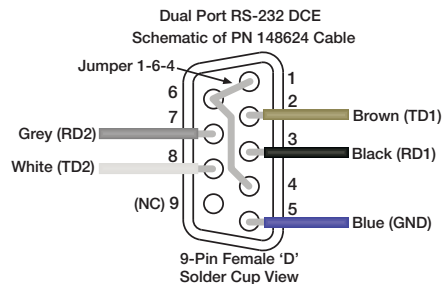

Figure 6-2. Standard Adapter Cable (PN 148624)

Connector – M12 industrial connector. An adapter cable (PN 148624) is required to connect the MSI-8000HD RF Remote Display to a computer. This adapter cable converts the 8000 connector to a standard D9 serial connector. The 503489 cable can be converted to DTE by using a Null Modem adapter.

Data Configuration – The data output is fixed at 8-1-N.

Baud Rate – The baud rate is not programmable. Port 1 baud rate is fixed at 9600. Port 2 baud rate is fixed at 38.4k. The bootloader for updating software is 38.4k baud.

Handshaking – No hardware handshaking is supported. Xon/Xoff software handshaking is always on.

This configuration plugged into standard DTE connector disables Comm Port 2. Turn Comm Port 2 off using Comm Port menu.

An unterminated cable is available (PN 143348) for wiring a connector to the M12 connector found on the MSI-8000HD RF Remote Display.

The following diagrams show how to wire standard D9 connectors to access Communications Port 1 or Communications Port 2:

The following diagrams show how to wire standard D9 connectors to access Communications Port 1 or Communications Port 2:

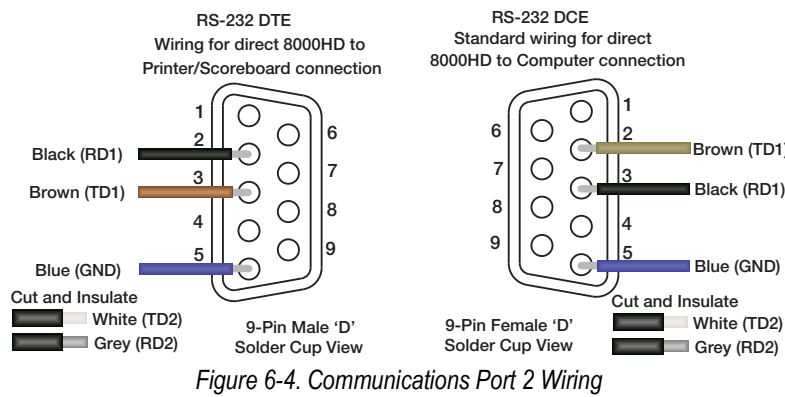
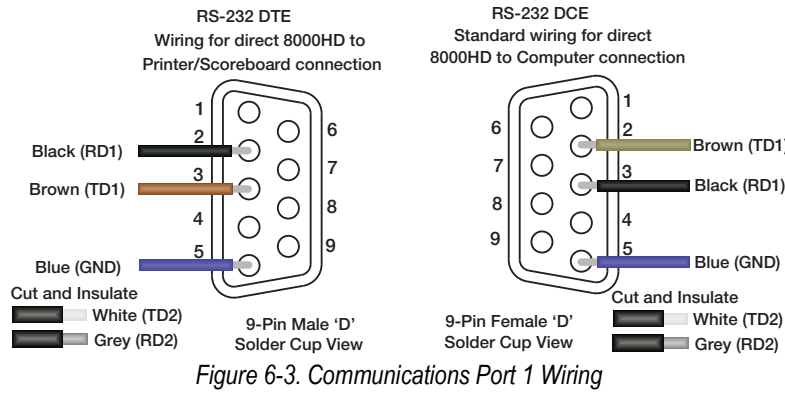

Wiring the shield drain to the metal shell of the connector is recommended, however, in some circumstances it may be necessary to disconnect the shield drain wire at the connector frame to prevent ground loops which can cause unstable readings. In extreme cases it may be necessary to use an isolated RS-232 interface.

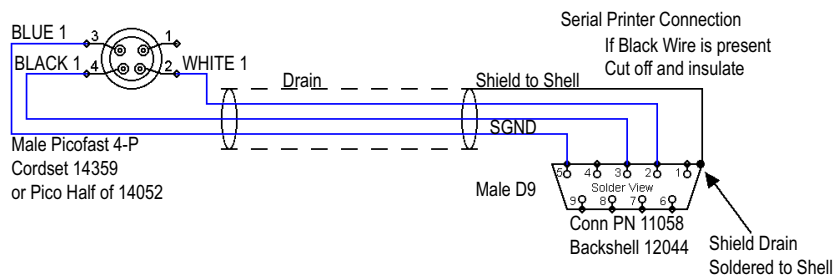
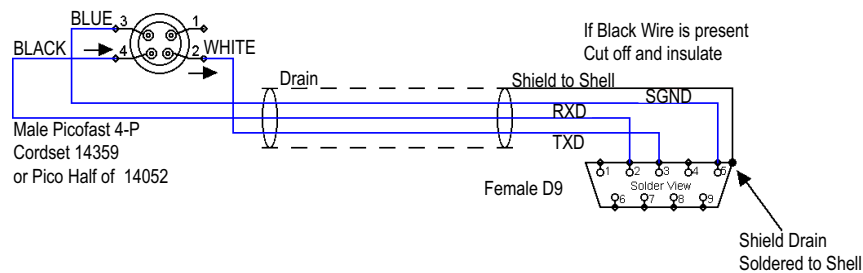

6.8 Real Time Clock

RTC capability enables the time and date to be included when printing load data. Time and date only display on the LCD screen during the power-on sequence or during the TEST sequence. Time displays in a 24-hour clock format and date displays as “YY-MM-DD”. Print time and date formatting is determined by the programmed print string.



NOTE: Time and date support is not available on older versions of the MSI-8000HD. If time and date support is not available, time and date will either not display during the display TEST or the time and date will show up as all zeros. If you would like time and date support and your MSI-8000HD does not support it, please contact your dealer.

Allows the setup of the time and date.

Mode	Description
YEAR	Two-digit year
Month	Month (1-12)
DAY	Day of the month (1-31)
hour	Hour on a 24-hour clock 0 — 12:00 am, midnight 1-11 — AM hours 12 — 12:00 pm, Noon 13-23 — PM hours
MINUTE	Minute (0-59)

Table 6-9. RF Setup Parameters

Press ZERO twice to save the time and date. Seconds reset to zero upon saving.

7.0 Troubleshooting

This section provides an overview of the MSI-8000 RF Remote Display troubleshooting and maintenance instructions.

Problem	Possible Cause	Solution
The display is blank when the power key is pressed	Discharged battery	Recharge the battery
	Defective battery	Replace the battery (factory replacement only)
	Defective switch or circuit board	Requires authorized service
The display does not function properly/front panel keys do not function normally/scale/Dyna-Link will not turn off	Improperly loaded software	Reinstall the software
	Faulty circuit board	Requires authorized service
	Loose connectors	Requires authorized service
Scale/Dyna-Link does not respond to tension changes	Out of calibration	Calibrate the unit
	Faulty load cell	Replace the load cell
	Load cell connector	Check connectors and wires
The display over ranges below 100% of capacity	Tared tension is added to load to determine overload point	Return to gross tension mode
	Zero requires adjustment	Rezero the scale
	Too much tension/load has been zeroed	Rezero the scale
The display drifts	AZM (Auto 0) is turned off	Turn AZM on
	Rapid temperature changes such as moving the scale from indoors to outdoors	Wait until the scale temperature has stabilized
Displayed tension shows a large error	Scale not zeroed before load is lifted	Zero the scale with no load attached
	lb/kg units causing confusion	Select proper units
	Requires recalibration	Recalibrate the unit
The display reading is not stable	Excessive vibration	Increase filtering or increase d in Cal
	Excessive side loading	Improve load train symmetry
	Load cell faulty	Check load cell connections
The display toggles between Error and Load	Load exceeds capacity	Reduce tension immediately
	Faulty load cell or wiring	Check load cell and load cell wiring
The display toggles between Error and Button	A key is stuck or is being held down	Check switches for damage
Weight is on the scale/Dyna-Link and RF Remote Display do not match	Units are not paired	See setting the RF Network address procedures
Lo Batt is blinking	The battery is low	Recharge the battery
The unit turns on, then immediately off	The battery is low	Recharge the battery
The load will not zero	The system not stable	Wait for stable symbol  to turn on Increase filtering for more stability
	Zero out of range	Zero range might be limited; Reduce the tension or use Tare instead
The load will not tare or total	The system not stable	Wait for the stable symbol  to turn on, or if in a noisy mechanical crane, increase the filtering or reduce the size of the scale increment d; It is also possible to increase the motion window; Contact Rice Lake Weighing Systems if there is a problem getting the unit to zero, tare or total due to issues
Setpoint lights blink	Set point is enabled and the trigger point has been reached	Disable set points if they are not needed
The manual total does not work	A function key is not set to total	Set up Func1 or Func2 for total
	Tension must be stable	Increase filtering for more stability
The auto total does not work	Load must be stable	Wait for stable symbol  to turn on or increase filtering for more stability
	Load thresholds are not reached	Weight must exceed 1% of capacity for auto total to work; Weight must drop below 0.5% of capacity for additional weighments to register
RTC does not stay updated when power is off	Coin-cell battery may be spent	Replace coin-cell battery (Section 7.6 on page 45)

Table 7-1. Troubleshooting Solutions

7.1 Error Codes

The MSI-8000 RF Remote Display ScaleCore processor detects errors and generates error codes to aid in troubleshooting.



Error Code	Definition	Comment
LCOFF	LC Disabled	A Load cell was not enabled
ZCAL	In Cal	The system is in calibration mode; Do not send commands unrelated to calibration
UnCAL	Not Calibrated	System has not been calibrated
 Error LoAd	Overload	Tension/Weight exceeds set capacity +9 d or load cell is damaged or disconnected
 Error UndLd	Underloaded	Tension/weight is more than 20% negative or load cell is damaged or disconnected

Table 7-2. Error Codes

7.2 Service Counters



WARNING: Service Counters are important safety warning features for the MSI Brand of Rice Lake Weighing Systems and can only be reset at the factory by personnel from MSI. As part of the reset process, the service technician will perform a thorough load train inspection to ensure user safety and confirm that the product is ready to be returned for regular service.

See Crane Scale Safety and Periodic Maintenance Manual (PN 153105) for proper loading techniques to improve the safety and longevity of your MSI Overhead Weighing Product.

All Rice Lake RF linked scales/Dyna-Link 2 maintain two service counters for safety.

- The LFCnt (first counter) counts lifts above 25% of capacity
- The OLCnt (second counter) counts the number of times the RF linked scale has been overloaded

These counters warn the user to inspect the load train after a number of overloads or a long term frequency of high capacity lifts. Power up will be interrupted when the lift counter exceeds 16383 lifts or the overload counter exceeds 1023 overloads. Inspect the load train then push any key to continue operation.

This feature is only available on MSI scales and RF transmitters connected directly to a load cell(s).

7.3 Mechanical Dimensions



Figure 7-1. Mechanical Dimensions

7.4 Firmware Update Procedure

Updating firmware in the MSI-8000 RF Remote Display requires the following: a DCE serial cable (MSI 503489-0001, or build per DCE cable schematic on page 28), a PC with a terminal program ("Teraterm Pro" recommended), and if the PC does not have standard RS-232 serial ports, then a USB to serial converter. Make sure the driver for the USB converter is properly installed, and that the Terminal program is set up for the proper comm port.

The latest firmware code is available from the MSI Service Department and can be emailed on request. The firmware version displays when the MSI-8000 RF Remote Display is turned on in form "01-04" (version may vary). MSI-8000 RF Remote Display firmware updates do not require a recalibration of the connected scale. Consult the version release notes for information regarding the updated code.

1. Setup the terminal serial port to 8 data bits, No Parity, 1 stop bit, 9600 BAUD, XON/XOFF (flow control).
2. Connect to the Dyna-Link serial port using the DCE cable. Connect the D9 connector to your PC or USB adapter.
3. (Optional) Test that you have a connection by typing {00FF01?}. If the connection is good the MSI-8000 RF Remote Display will respond with {000001r2;0;01E02;2011-07-08;11:05} or something similar.
4. On the terminal keyboard, type {ffff09=0199}.

- Change the terminal serial port to 38400 BAUD. Hit the 'r' key to refresh the display.

The following menu should appear:

MSI-8000 RF Remote Display SCALECORE2 BOOT LOADER Ver. 00-05 (c) 2012-05-02 10:55

- (u) Download and program application code (bootloader version may vary)
- (q) Query app code info
- (g) Execute app code
- (r) Refresh



The bootloader version may vary.

- Type u.

Terminal should display:

Send File NOW, or press ^ to abort:

- Send the .prg file using the file send feature of your terminal program. The character “#” will tick away as the ScaleCore programs.

Send File NOW, or press ^to abort: #####

#####

Completed

- After file is received terminal should display “Completed.” Then the boot menu appears again.

MSI-8000 SCALECORE2 BOOT LOADER Ver. 00-05 (c) 2012-05-02 17:06

- (u) Download and program application code (bootloader version may vary)
- (q) Query app code info
- (g) Execute app code
- (r) Refresh

- Optional step: send q to check the program. The ScaleCore will respond with a message that details the 32b checksum, the product ID and version, and the Application Code version number in the following form:

Computed Signature 76F481D8 **32b CRC must match (76F481D8 is an example only)**

Received Signature 76F481D8

Product ID 07 MSI-8000 product family

Product Version ID 00 Optional features code

App Code Version 01-04 Firmware version number

If the CRC Signature does not match, go back to [Step 2 on page 43](#) and try again.

- Send an “r” to restore the boot menu.



MSI-8000 SCALECORE2 BOOT LOADER Ver. 00-05 (c) 2012-05-02 10:55

- (u) Download and program application code (bootloader version may vary)
- (q) Query app code info
- (g) Execute app code
- (r) Refresh

- Send a “g.” The MSI-8000 RF Remote Display should start.

7.5 Reset the Remote Control

Resetting the unit will change all settings back to the default factory settings.

- Press the calibration switch and  simultaneously. *SUR-E²* displays.
- Press  to reset the current indicator settings to the default factory settings. *LR* displays.
- An initial calibration will need to be performed on the current load cell ([Section 5.1 on page 24](#)).



IMPORTANT: Pressing  will reset only the current load cell calibration settings ([Section 5.5 on page 28](#)).



NOTE: Press the  to cancel reset and return to the previous menu.

7.6 Coin-Cell Battery Replacement

The RTC utilizes a CR2016 coin-cell battery to maintain time and date while the MSI-8000HD remote display is disconnected from a power supply. If the MSI-8000HD no longer updates the time and date while the power is disconnected from a power supply, the battery may need to be replaced. Battery life is expected to be approximately 5 years with a fresh battery.



WARNING: Dispose of batteries at appropriate waste collection centers at the end of their life cycle in accordance with local laws and regulations. Batteries and rechargeable batteries may contain harmful substances that should not be disposed of in household waste. Batteries may contain harmful substances including but not limited to: cadmium (Cd), lithium (Li), mercury (Hg) or lead (Pb). Users who dispose of batteries illegally shall face administrative sanctions as provided by law.

To replace the coin-cell battery, the circuit board must be detached from the mounting bracket. A #1 Phillips screwdriver and a flathead screwdriver are needed for the procedure.

1. Disconnect the power cable from the power source.
2. Pull the rubber wrap back to expose the screw holes on the back of the MSI-8000 RF Remote Display.
3. Remove the 4 phillips screws on the back of the MSI-8000 RF Remote Display with a screwdriver.
4. Remove the rear cover.
5. Gently lift the black cable lock on the back edge of the P6 LCD connector
6. Carefully remove the LCD ribbon cable by pulling it gently out of the P6 port.

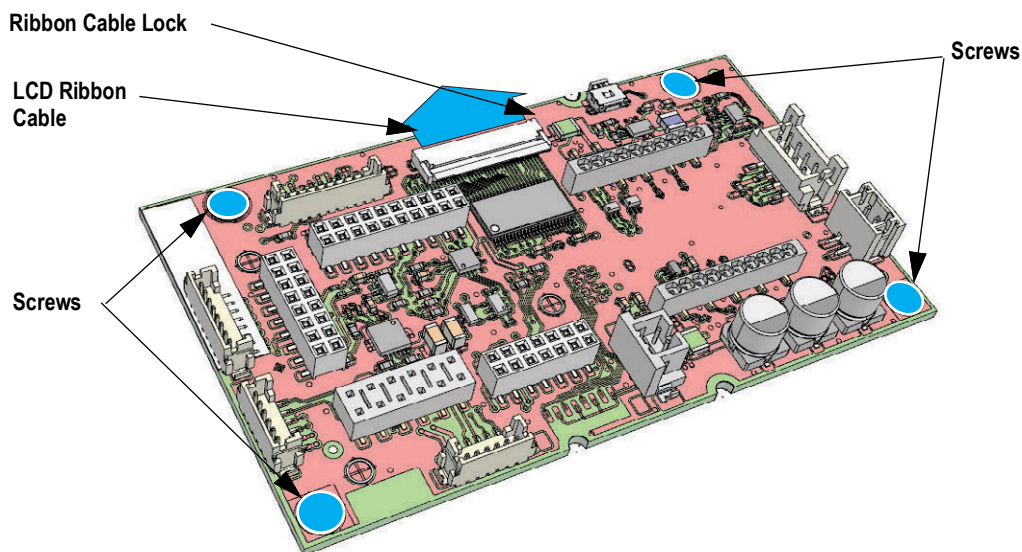

Figure 7-2. CPU Board Top

7. Remove the four screws securing the circuit board to the mounting bracket.
8. Gently flip the circuit board over, being careful not to twist or damage the push button flex cable.

- Carefully remove the coin-cell battery from the battery holder with a small flathead screw driver.

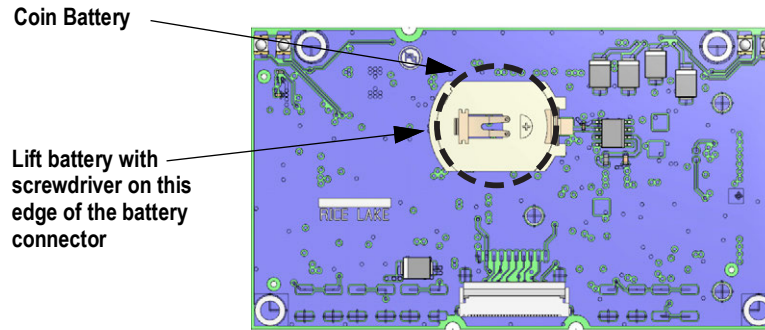

Figure 7-3. CPU Board Bottom

! **IMPORTANT:** Attempting to directly lift the coin-cell battery without a screwdriver could result in pulling the battery holder off of the circuit board. If the battery holder is pulled off of the circuit board, the entire board must be replaced.

- Replace the battery in the holder with the positive side facing up.
- Flip the circuit board back over and loosely replace the four screws into the mounting bracket.
- Fully and evenly replace the LCD ribbon cable into the P6 port, shifting the circuit board if necessary.
- Switch the black cable lock down to secure the ribbon cable in place.
- Gently tighten the screws to secure the circuit board to the mounting bracket.
- Ensure that the gasket is seated directly in the channel.
- Replace the rear cover, ensuring that the gasket is seated directly in the channel.
- Replace the 4 phillips screws on the back cover.

8.0 Specifications

Enclosure

NEMA Type 4, IP65

Weight

0.98 lb (445 g)

Keypad

On/Off, Zero (100%), Tare, Print, and two user-defined keys for the following functions: peak hold, high resolution, total, view total, net/gross, units switching

Display

6-digit 1.0 in (26.4 mm) LCD

Units Displayed

Pounds, kilograms, tons, metric tons, kilonewtons

Annunciators

Stable, COZ, low battery, peak, net, kg, kN, lb, M, ton, setpoint, function LEDs

Power

Integral lithium ion battery

Universal 115/230 VAC, 50/60 Hz battery charger

(NA plug included)

Operating Time

Up to 24 hours of continuous use (15 minute auto-shutoff with non-use)

Operating Temperature

-4°F – 140°F (-20°C – 60°C)

RF Radio Link

2.4 GHz 802.15.4

communicates with RF 3460, 4260, 7300, 7000 & 7001

RF Effective Range

Typically < 100 ft to 300 ft, line of sight; for longer range consult factory

Connector

Four-pin Turck connector for charging and RS-232 communication

Warranty

One-year limited



© Rice Lake Weighing Systems Content subject to change without notice.

230 W. Coleman St. • Rice Lake, WI 54868 • USA USA: 800-472-6703 • International: +1-715-234-9171