

MAS-M

Mobile Group Livestock Scale

Installation Manual



© Rice Lake Weighing Systems. All rights reserved.

Rice Lake Weighing Systems® is a registered trademark of
Rice Lake Weighing Systems.

All other brand or product names within this publication are trademarks or
registered trademarks of their respective companies.

All information contained within this publication is, to the best of our knowledge, complete and
accurate at the time of publication. Rice Lake Weighing Systems reserves the right to make
changes to the technology, features, specifications and design of the equipment without notice.

The most current version of this publication, software, firmware and all other product
updates can be found on our website:

www.ricelake.com

Revision History

This section tracks and describes manual revisions for awareness of major updates.

Revision	Date	Description
L	June 17, 2024	Established revision history; Updated replacement parts

Table i. Revision Letter History



Technical training seminars are available through Rice Lake Weighing Systems. Course descriptions and dates can be viewed at www.ricelake.com/training or obtained by calling 715-234-9171 and asking for the training department.

Contents

1.0	Introduction	1
1.1	Overview	1
1.2	Safety	2
1.3	Animal Safety	2
1.4	Calibration	2
1.5	Safety Decals	3
1.6	Non-Safety Decals	4
1.7	Unloading	5
1.7.1	Slinging the Scale	5
1.7.2	Lift the Scale	5
1.7.3	Remove Lifting Fixture	6
1.8	Lifting Assembled Scale	6
1.9	Package Removal	6
2.0	Installation	7
2.1	Cage Wall Assembly	7
2.1.1	Apply Silicone Bead	7
2.1.2	Install Walls	8
2.1.3	Install the Gate	8
2.1.4	Gate and Latch Adjustment Procedure	9
2.2	Hitch Assembly	9
2.3	T-Belt	10
2.4	Optional 920i Weighcenter Mounting	10
2.5	Wiring the Scale	11
2.6	Load Cell Wiring Diagrams	13
3.0	Towing Instructions	14
3.1	Switching Modes	15
3.1.1	Converting to Weigh Mode	15
3.1.2	Converting to Transport Mode	17
4.0	Repair Parts	18
5.0	Maintenance	27
5.1	Maintenance Schedule	27
5.2	Scale Maintenance Procedures	28
5.2.1	Cleaning Load Cell Stands	28
5.2.2	Disassembly and Greasing	28
5.3	Brake Maintenance	29
5.3.1	How to Use The Electric Brakes Properly	29
5.3.2	Synchronizing The Scale Brakes	29
5.3.3	Brake Adjustment	29
5.4	Hubs, Drums and Bearings Maintenance	30
5.4.1	Bearing Adjustment	30
5.4.2	Lubricate Hubs	30
5.5	Gathering Panel Attachment	31
5.6	Troubleshooting	32
5.7	Towing Checklist	33
6.0	Specifications	34



Rice Lake continually offers web-based video training on a growing selection of product-related topics at no cost. Visit www.ricelake.com/webinars

1.0 Introduction

This system is manufactured with top quality components and is engineered using the latest technology to provide operating features and reliability unmatched for years to come.

Please take the time to read this manual completely through before attempting to use the system. Although the MAS-M has been designed for easy setup and use, a thorough understanding of this manual will ensure that the user will receive the maximum benefit from the system.



Manuals are available from Rice Lake Weighing Systems at www.ricelake.com/manuals

Warranty information is available at www.ricelake.com/warranties

1.1 Overview

The MAS-M is an agricultural implement consisting of a scale with air ride suspension and swing out hitch, a sheeted animal cage suspended by four S-type load cells through a cam style on-board scale system, and weigh center. In **Transport Mode** the scale system is locked down, protecting the load cells from damage during transport. To convert to **Weigh Mode** the entire scale is lowered to the ground, the hitch is split and swung outward and the scale is raised to the **Weigh Mode** using a lever and cam system. The weigh center contains the digital indicator and ticket printer. To convert back to **Transport Mode** the process is reversed, see [Section 3.0 on page 14](#) for more details.

The MAS-M can be used on any firm surface up to 6% grade (3° slope) and has a low deck height (6 in) for easy step-in.



Figure 1-1. MAS-M Mobile Group Livestock Scale

1.2 Safety

Safety Definitions:



DANGER: Indicates an imminently hazardous situation that, if not avoided, will result in death or serious injury. Includes hazards that are exposed when guards are removed.



WARNING: Indicates a potentially hazardous situation that, if not avoided, could result in serious injury or death. Includes hazards that are exposed when guards are removed.



CAUTION: Indicates a potentially hazardous situation that, if not avoided, could result in minor or moderate injury.



IMPORTANT: Indicates information about procedures that, if not observed, could result in damage to equipment or corruption to and loss of data.

General Safety



Do not operate or work on this equipment unless this manual has been read and all instructions are understood. Failure to follow the instructions or heed the warnings could result in injury or death. Contact any Rice Lake Weighing Systems dealer for replacement manuals.



WARNING

Failure to heed could result in serious injury or death.

Do not allow minors (children) or inexperienced persons to operate this unit.

Do not operate without all shields and guards in place.

Do not use for purposes other than weighing.

Do not place fingers into slots or possible pinch points.

Do not place hands, feet or any body part underneath the scale at any time. The scale could be lowered, crushing body parts.

Do not use any load bearing component that is worn beyond 5% of the original dimension.

Do not use this product if any of the components are cracked.

Do not exceed the rated load limit of the unit.

Do not make alterations or modifications to the unit.

Do not remove or obscure warning labels.

Keep hands, feet and loose clothing away from moving parts.

Ensure that everyone is clear of any moving parts when lowering the scale.

Use two hands when gripping the lift handle to raise or lower the scale.

Be sure the gates are latched or tied inward before transporting the scale.



IMPORTANT

Ensure all three hitch lock pins are installed and the suspension stops are in the transport position before moving the scale.

This unit is not intended for the transportation of livestock or any other goods. Any addition of weight to the scale in Transport Mode may cause premature component failure and voids the Rice Lake warranty.

1.3 Animal Safety

Animal safety is a very serious issue and must be observed when handling any type of animal.

The scale surface may become slippery during use; a build-up of manure on the scale may reduce traction. It is recommended that you take any necessary precautions to maintain an acceptable level of animal footing.

1.4 Calibration

Do not calibrate this scale with a weight cart having a gross weight in excess of 25% of the total capacity of the scale (MAS-M 8 x 13 – 3,750 lb or 1,700 kg max/ MAS-M 8 x 18 – 5,000 lb or 2,268 kg max). This device is designed to be calibrated with single block weights spread evenly throughout the floor of the scale. Shift tests should not be done with more than 4,000 lb or 1,815 kg in a 4 ft x 4 ft area. Failure to comply with this warning will result in damage to the scale and void the warranty.

1.5 Safety Decals

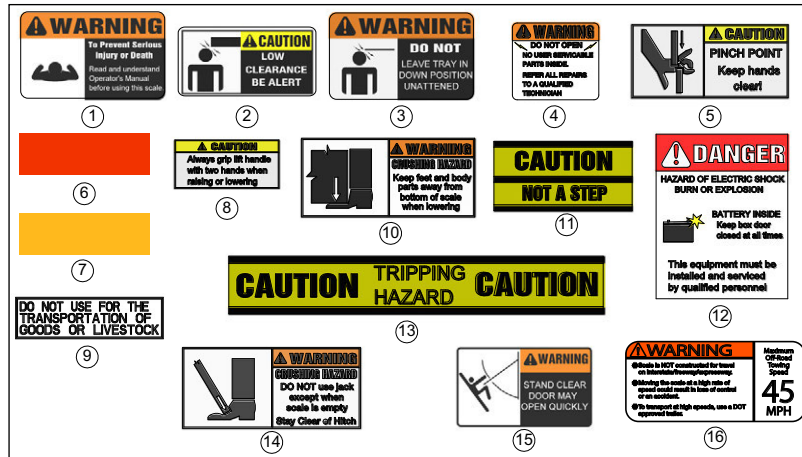

Figure 1-2. Safety Decals

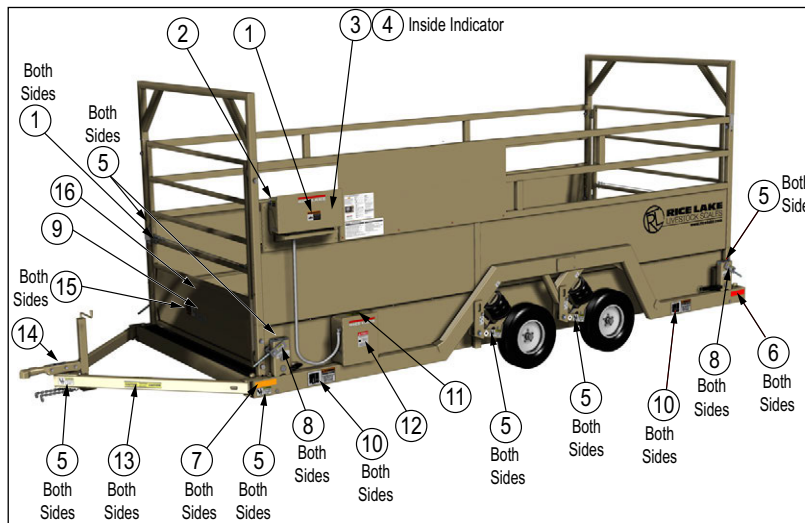

Figure 1-3. Location of Safety Decals



NOTE: Items 2-4 are on units equipped with the 920i Weighcenter only.

Item No.	Part No.	Description	Qty.
1	151908	Read Manual	3
2	151904	Caution, Low Clearance (Weighcenter)	1
3	151906	Warning, Do Not Open (Weighcenter)	1
4	151907	Warning, Do Not Leave Tray Down (Weighcenter)	2
5	151909	Caution, Pinch Point	14
6	127383	Tape, Red	4
7	131052	Tape, Yellow	2
8	151910	Caution, Always Grip With Two Hands	4
9	128266	Do Not Use For Transportation of Goods	2
10	151898	Warning, Crushing Hazard	7
11	151901	Caution, Not A Step (Battery Box)	1
12	151900	Warning, Battery (Battery Box)	1
13	151897	Caution, Tripping Hazard	2
14	151905	Warning, Crushing Hazard (Jack)	1
15	151902	Warning, Opens Quickly	2
16	177238	Test Weight Label	1

Table 1-1. Safety Decals Parts List

1.6 Non-Safety Decals

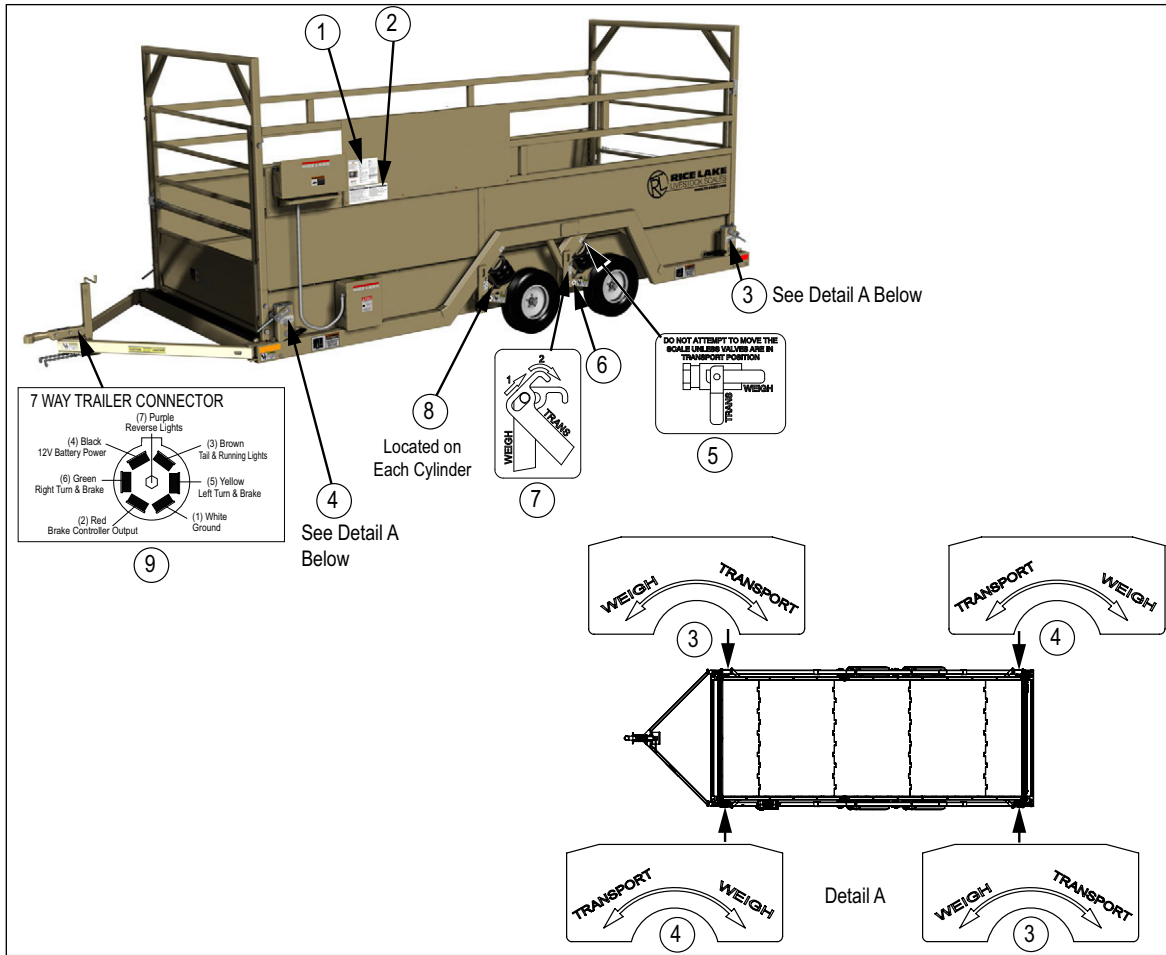

Figure 1-4. Non-Safety Decal Locations

Item No.	Part No.	Description	Qty.
1	164911	Label, 920i Weighcenter Operation	1
2	127090	Label, Basic Operation	1
3	132692	Label, Weigh/Transport	2
4	127094	Label, Weigh/Transport	2
5	127098	Air Valve Position, Each Axle	2/4
6	126866	Label, Grease Fitting, Each Axle	2/4
7	127099	Transport Position, Left, Each Left Axle	1/2
	127100	Transport Position, Right, Each Right Axle	1/2
8	127093	Label, Hitch Plug	1
9	127092	Label, Ride Height, Located on Each Cylinder	2/4

Table 1-2. Non-Safety Decals Parts List

1.7 Unloading

Follow instructions below to unload the scale.

1.7.1 Slinging the Scale

The MAS-M can be slung using four straps connected from the lifting lugs to a single point in the center. To obtain a lifting point closer to the center of gravity, straps should be one to two feet longer on the rear of the scale.

- Strap length 8 x 13 = 6 ft minimum
- Strap length 8 x 18 = 9 ft minimum

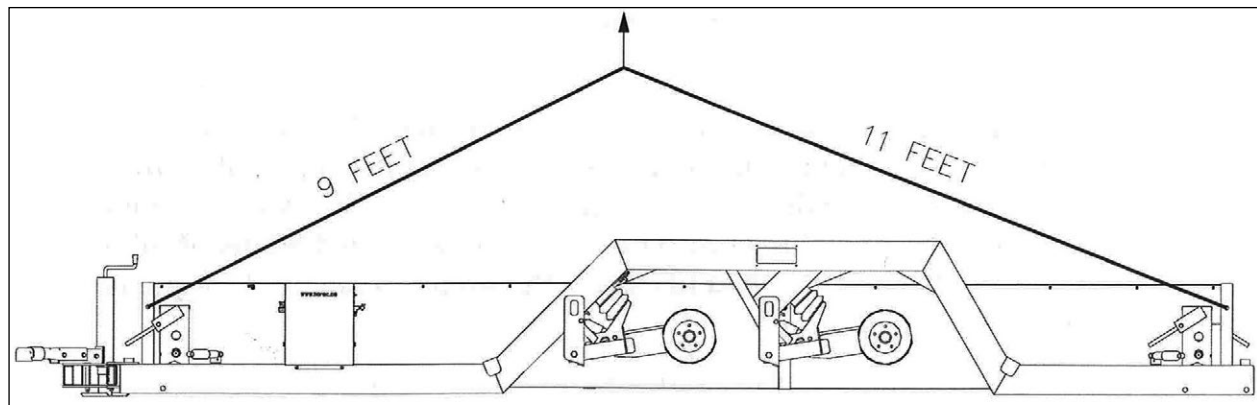

Figure 1-5. Slinging the Scale

1.7.2 Lift the Scale

1. If stacked, monitor the four corners directly below the lifting fixtures. Each corner has a shipping stub inserted; these stubs are not bolted in place. Ensure they remain with the lower scale.
2. Once the upper scale of the stack is removed, the stubs can be discarded.

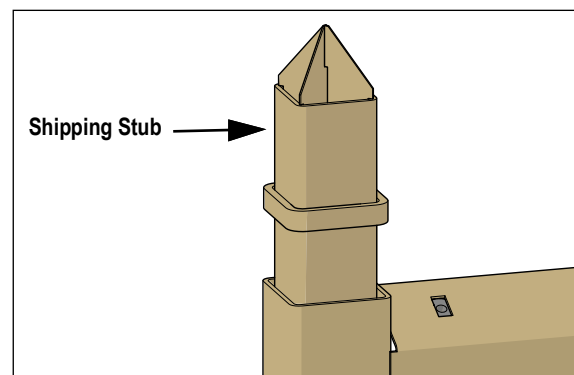

Figure 1-6. Shipping Stub

3. The scale can now be stored as is or placed on a relatively flat location to be assembled.

1.7.3 Remove Lifting Fixture

Remove lifting fixture after scale has been placed in position.

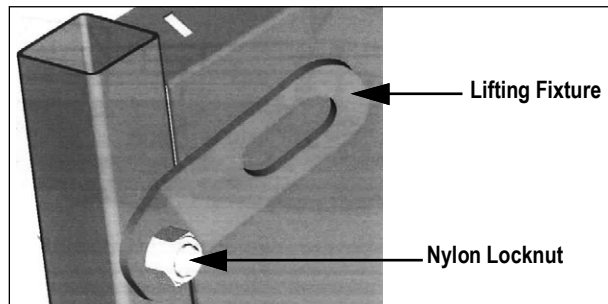

Figure 1-7. Lifting Fixture

1. Remove the nylon locknut from the bolt installed for shipping.
2. Remove lifting fixture from bolt.
3. Reinstall nut, retain lifting fixture for future moves.

1.8 Lifting Assembled Scale

Lift scale only in designated locations. The scale may be lifted by four straps and a crane or loader.



NOTE: Ensure scale is in the Transport Mode (locked down – [Section 3.1.2 on page 17](#)) when loading and transporting.

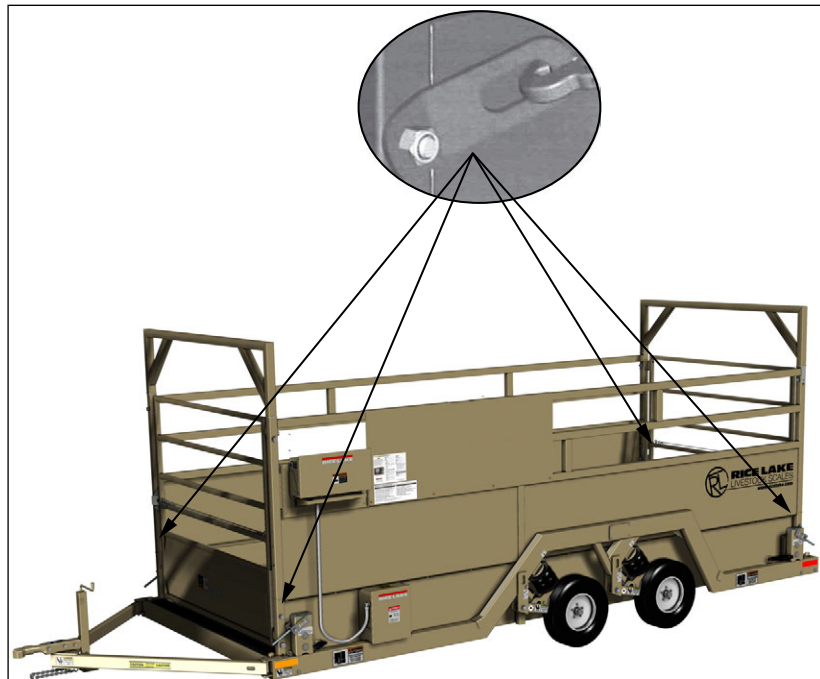

Figure 1-8. Lift Points



NOTE: Install lifting fixtures inside each corner, as shown in [Section 1.7.1 on page 9](#). Install cable hooks to each lifting fixture to lift.

1.9 Package Removal

Indicator and tires are shrink-wrapped for transportation. Be careful when removing to avoid damaging the indicator or tires. Remove the tires and indicator, then re-strap the walls if the scale is to be transported while packaged.

2.0 Installation

It is important to apply and maintain proper wheel mounting torque on the scale axle. Torque is a measure of the amount of tightening applied to a fastener (nut or bolt) and is expressed as length times force. Torque wrenches are the best method to assure the proper amount of torque is being applied.



NOTE: Wheel bolts/nuts must be tightened and maintained at the proper torque levels to prevent loose wheels, broken studs and possible dangerous separation of wheels from the axle. Be sure to use only the fasteners matched to the cone angle of the wheel (usually 60° or 90°).

The procedure for attaching the wheels is as follows:

1. Start all bolts/nuts by hand to prevent cross threading.
2. Tighten bolts/nuts in the sequence shown in Figure 2-1.
3. Tighten fasteners per torque chart in Table 2-1.
4. After wheel nuts have been torqued, use a white marker to mark the end of each stud to show they have been torqued.

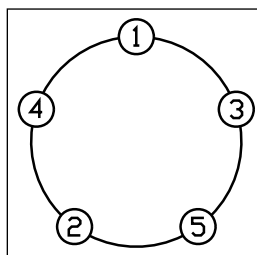

Figure 2-1. Wheel Torque Pattern

Wheel Torque Sequence (ft-lb)		
1st Stage	2nd Stage	3rd Stage
20-25	50-60	90-120

Table 2-1. Wheel Torque



IMPORTANT: Wheel bolts/nuts should be re-torqued after the first 10 miles, 25 miles and 50 miles.

2.1 Cage Wall Assembly

2.1.1 Apply Silicone Bead

Before installing the walls, a silicone bead must be added.

1. Clean the upper flange of the floor and the lower wall flange with mineral spirits.
2. Apply a 1/8 in bead of silicone along the upper edge of the floor panel along the entire length.

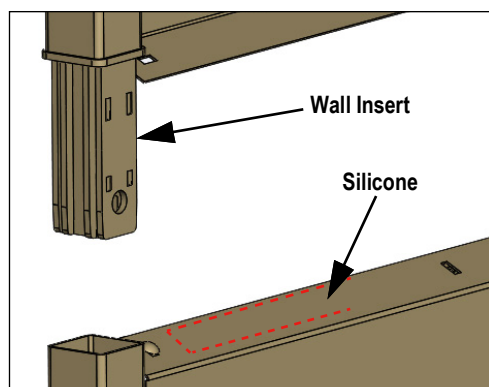

Figure 2-2. Silicone Bead

2.1.2 Install Walls



WARNING: Wall installation should be done with two people or an overhead crane.



NOTE: The wall with holes for the indicator is mounted on the left side.

1. Lift the first wall using one sling in the center.
2. Stand the wall vertical and place the inserts from the wall into the tubes of the cage floor. The more vertical the wall, the easier assembly is.
3. Repeat for opposite wall.
4. Install the top cross members.
5. Insert 3/4 in x 3 1/2 in bolts through the cage wall and inserts on the indicator side of the cage (head of bolt to the inside).



NOTE: A come-along from the top of the cross member to bottom of the cage corner post may be required. A ratchet strap is provided in hardware kit.

When both walls are in place, ensure they are perfectly square. Straps may need to be used to pull for squareness.

2.1.3 Install the Gate



NOTE: Install the gate with the hinge bolts on the opposite side of the scale.

Hinge bolts must be assembled with lock washer on the inside of gate and the jam nut on the outside.

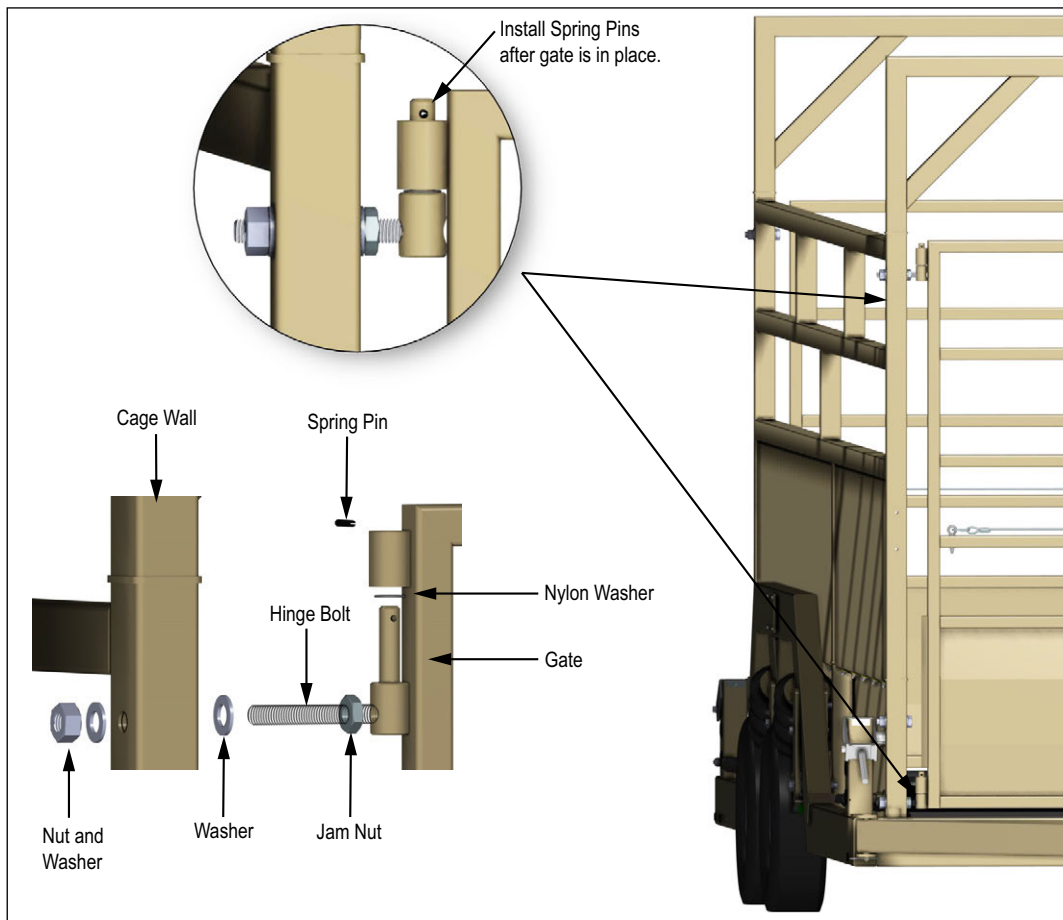

Figure 2-3. Assemble Gate to Scale

1. Install the jam nut and lock washer onto the hinge bolts. Screw the nut on about 2 in.
2. Insert one hinge bolt into the lower and upper holes of the cage wall with the hook portion pointing upward.

3. Install nut and washer onto the hinge bolts, securing them to the cage wall.
4. Place a nylon washer onto the hook portion of the upper and lower hinge bolts and install the gate onto the hooks.
5. Insert the roll pin through the hinge bolts.
6. Repeat [Step 2 on page 12](#) – [Step 4](#) for the second gate.
7. Adjust the hinge side gap between the gate and the cage wall until the strike plate is centered (about 3 in between gate and wall) then tighten hinge bolts.

2.1.4 Gate and Latch Adjustment Procedure



NOTE: The gates should be assembled following the listed criteria:

Hinge Bolts – Assemble with lock washer on inside of gate and jam nut on outside.

Hinge Side Gap – Approximately 3 in between the gate and the corner post.

Adjust gates as follows:

1. Adjust the hinge bolts to align the top of the gate on the latch side with the top of the cage wall.
2. Adjust the hinge bolts so the latch side gap is about 1 1/2 in.
3. Install and adjust the latch so the gate latch pin does not rub on the top or bottom of the latch. Adjust the hinge bolts only if necessary.



NOTE: Ratchet straps may be used diagonally to help square up gates to walls.

2.2 Hitch Assembly



NOTE: If the hitch arms do not come mounted, assemble the hitch arm with the coupler to the right side of the frame using the bolt and nut installed in the hole. Assemble the remaining hitch arm to the left side of the frame.

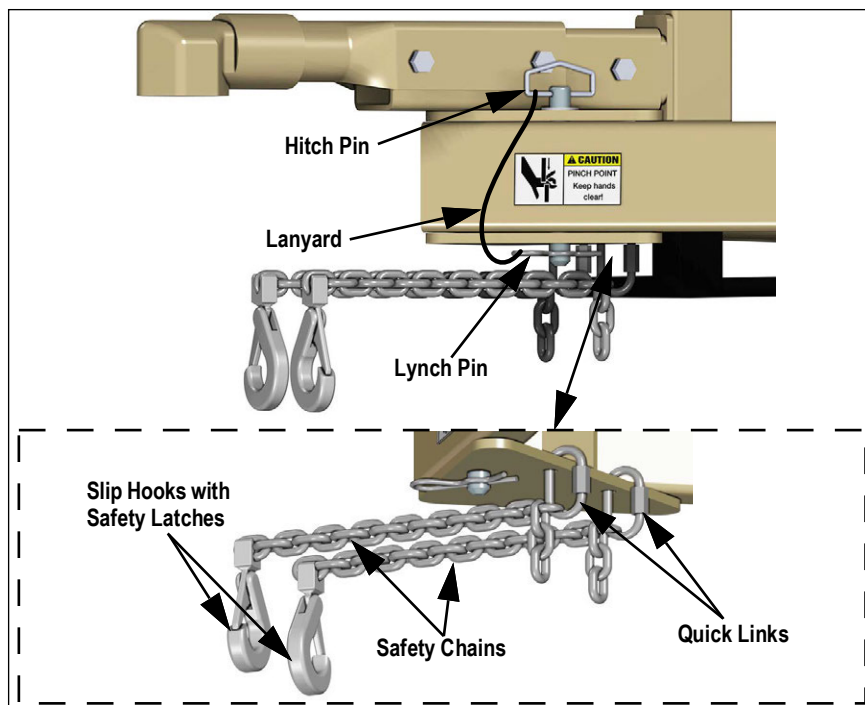

Figure 2-4. Safety Chain and Hitch Pin Locations

1. Connect the two halves of the hitch and install the hitch pin through both left and right hitch members.
2. Secure the hitch pin with a lynch pin.
3. Connect the slip hook with the safety latch onto one end of each chain.
4. Install the quick link into the fourth link of the chain on the opposite end of the slip hook.
5. Insert the quick link into the bottom holes on the hitch mounting plate.
6. Assemble the jack and tighten bolts.
7. Install safety chains, power cable and connect breakaway switch ([Section 3.0 on page 14](#)).

2.3 T-Belt

Ensure the T-Belt hold down loops are installed and hooked into the corner posts of the cage.

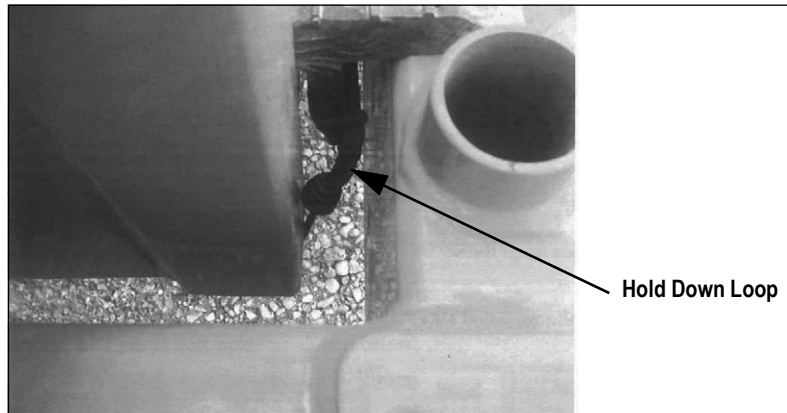

Figure 2-5. T-Belt

2.4 Optional 920i Weighcenter Mounting



NOTE: NTEP approved only when purchased with 920i Weighcenter. When using other indicators, it must be re-calibrated each time it's moved.

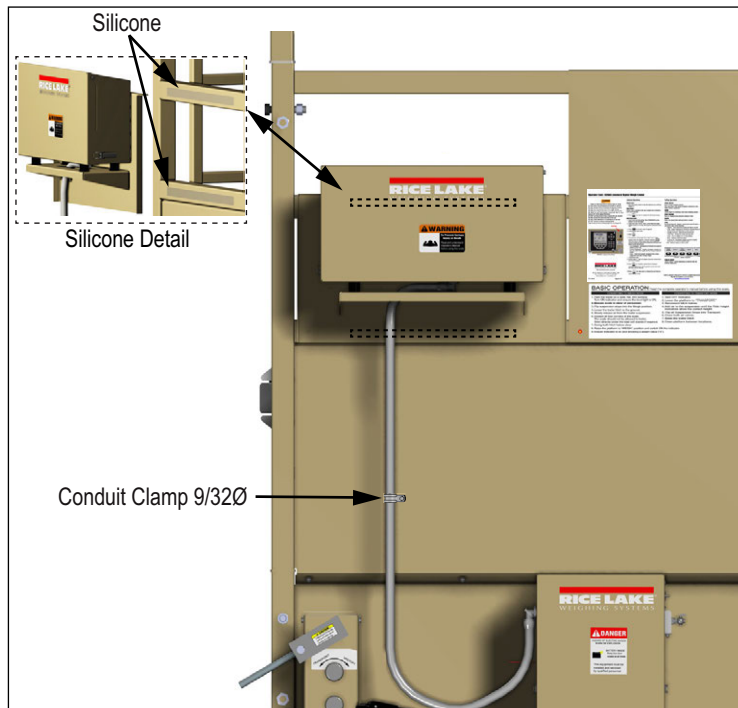

Figure 2-6. Weighcenter Mounting

1. Before installing the bracket, a bead of silicone must be added.
2. Use mineral spirits to clean wall tubes where bracket will mount and the space between the holes on the mount bracket.
3. Place the mounting bracket onto the cage wall by pressing the adhesive tightly to the cage.
4. Secure with four bolts.
5. Mount the weighcenter onto the mounting bracket and route the cable.
6. Install the clamps to secure the conduit.
 - Mount the upper conduit clamp using the lower left mounting bracket bolt
 - Secure lower end of conduit by drilling a hole through the cage sheeting and install the clamp with the bolt provided

2.5 Wiring the Scale

Battery Box Connections

1. Connect the scale cable and secure with a cable tie.
2. Connect the power wires.
3. Replace the battery cover.

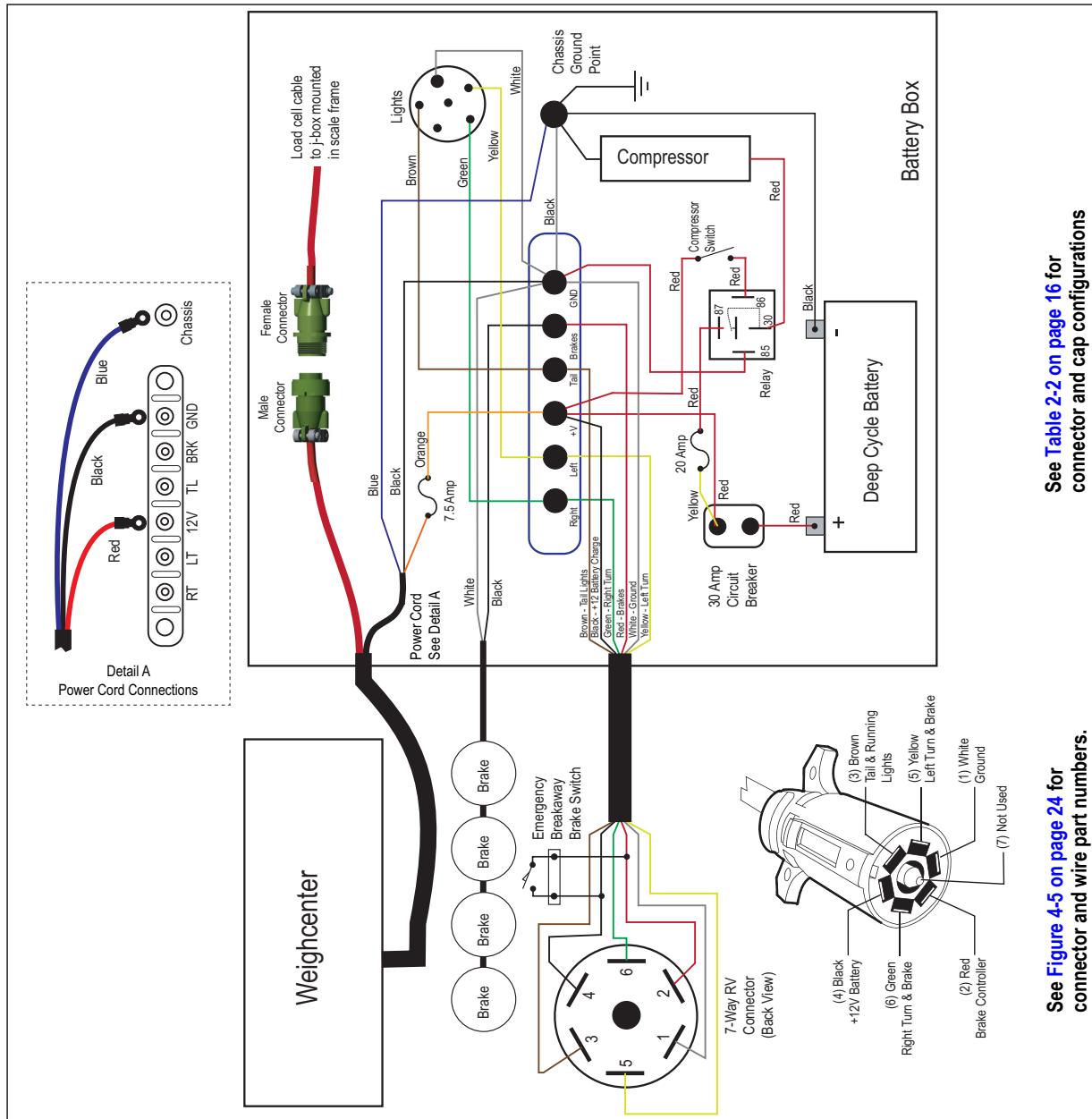

Figure 2-7. System Wiring Diagram

See Table 2-2 on page 16 for connector and cap configurations

See Figure 4-5 on page 24 for connector and wire part numbers.

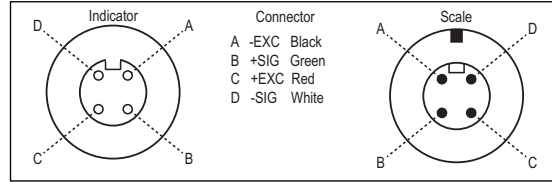

Figure 2-8. System Connections

Conn PN	Description	Used With	Cap PN	Cap Description
127259	Conn, MS, Male Complete Kit	127260 or 127261	15731	Dust Plug, MS External THD
127260	Conn, MS, Female Pins w/ clamp	127259	15730	Dust Cap, MS INTL THD

Table 2-2. Weighcenter Connector and Plug Configurations

Function	Color	Wire*	Where to Attach Vehicle Side	Where to Attach Scale Side
Right Turn	Green	16	Right turn of vehicle's wiring harness	Scale's right turn signal
Left Turn	Yellow	16	Left turn of vehicle's wiring harness	Scale's left turn signal
Ground	White	12	Vehicle ground point metal, uncoated, rustproof	Scale's ground point metal, uncoated, rustproof
Tail/Marker	Brown	16	Tail light of vehicle's wiring harness	Scale's tail lights
Brake	Blue	12	Electric brake control	Scale brakes
Battery	Red	12	Fuse block or fused battery lead	Breakaway kit
Back Up	Purple	16	Back up of vehicle's wiring harness	Back up lights (if available)

*Suggested minimum wire gauge for 7-way connector.

Table 2-3. 7-Way Connector Wiring



NOTE: Identify the wires on your vehicle and scale by function only. Color coding is not standard among all manufacturers.

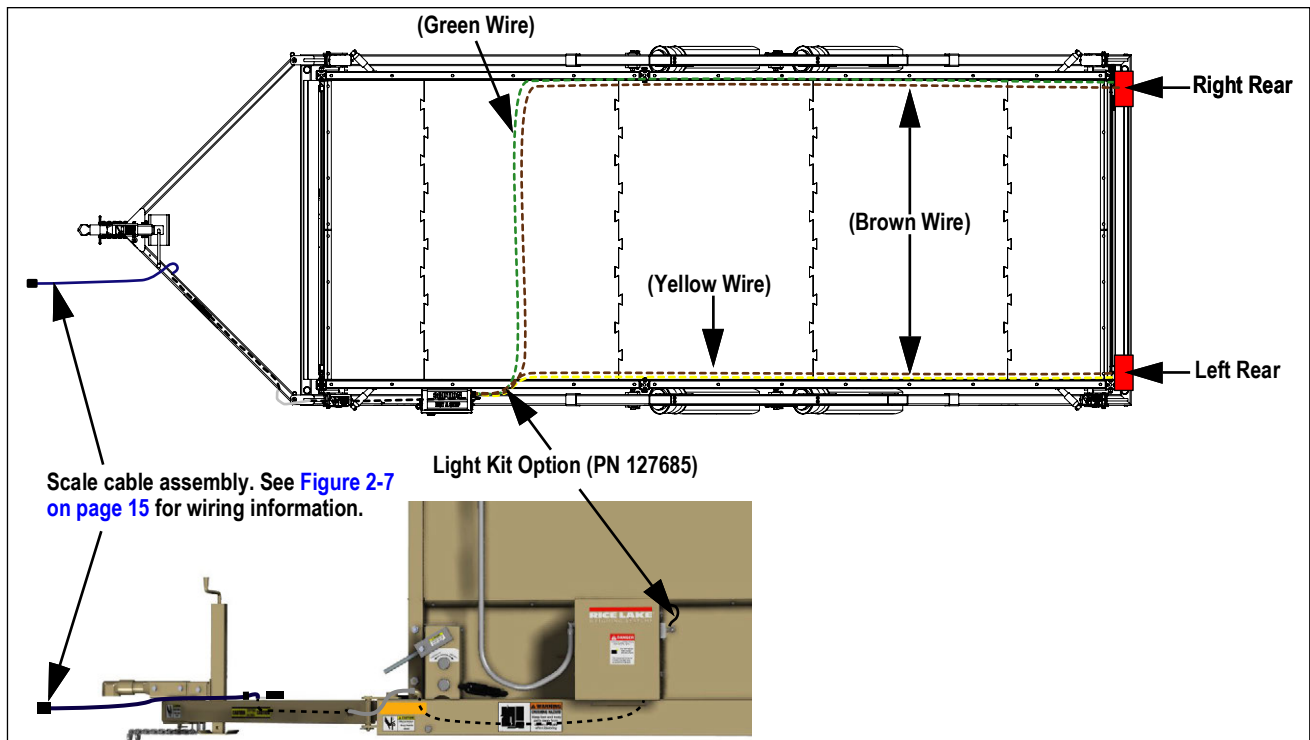

Figure 2-9. Scale Wiring Diagram

2.6 Load Cell Wiring Diagrams



NOTE: Load cell wiring shown is effective for all models later than 09/17/2013, models built prior to that date should rewire the scale to the updated configuration. For information on rewire, download Technical Bulletin (PN 159193) from www.ricelake.com.

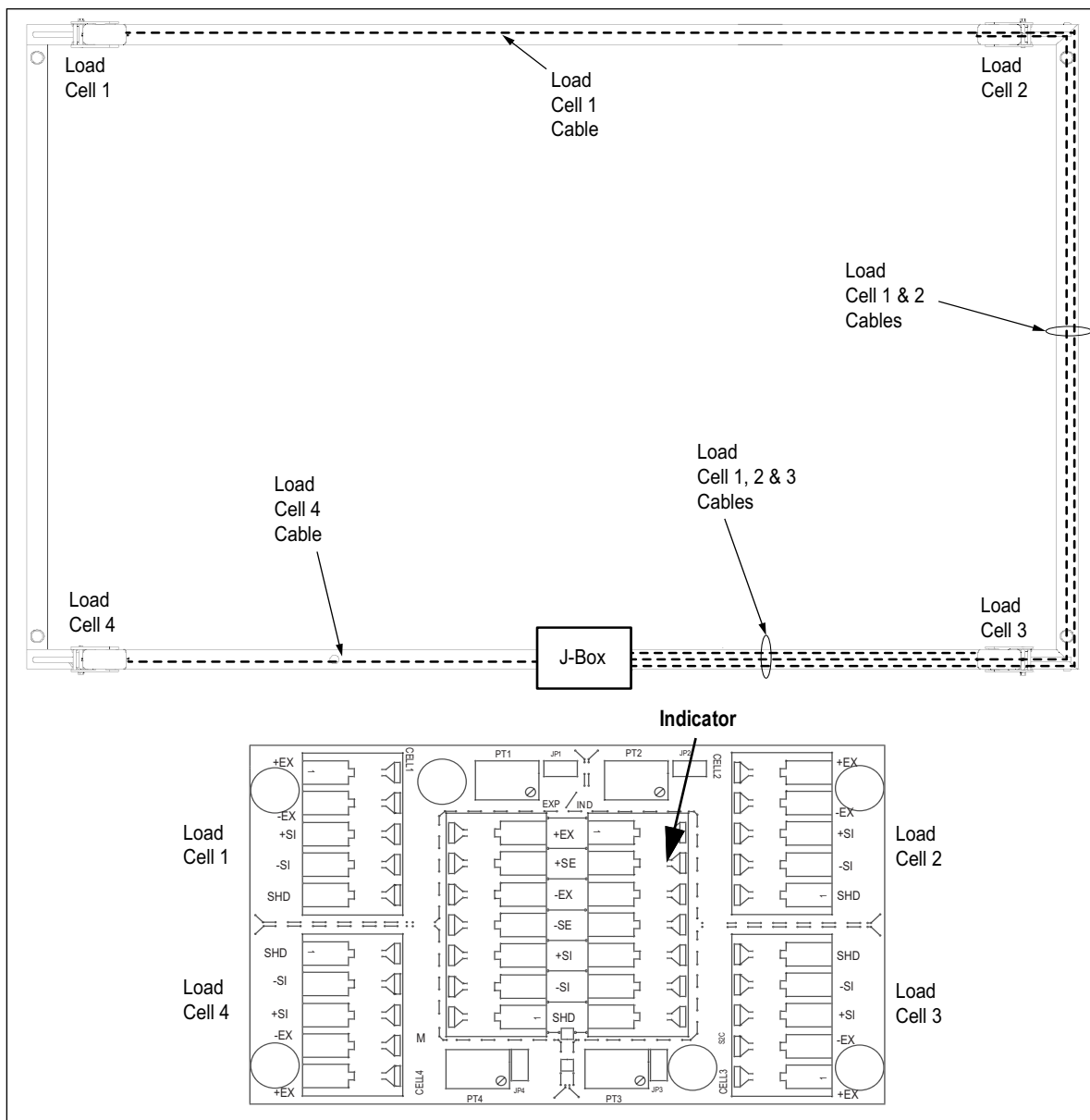

Figure 2-10. Load Cell Wiring Diagram

3.0 Towing Instructions

WARNING: This unit is not intended for the transportation of livestock or any other goods. Any addition of weight to the scale in Transport Mode may cause premature component failure and voids the Rice Lake warranty.

Read these instructions before towing.

The scale must be in **Transport Mode** to be towed. See [Section 3.1.2 on page 21](#) for converting to **Transport Mode**.

The scale is designed to be towed level (frame parallel to the ground) using a 2 in ball. To achieve the level towing condition, the required hitch height of the towing vehicle must be approximately 16 in. If the hitch of the towing vehicle is not in this range, use an adapter to achieve a height in this range. The hitch weight of the scale is approximately 500 lb. An equalizer hitch may be used for towing if desired (such as the EAZ-LIFT Adjustable Weight Distributing Hitch #1009).

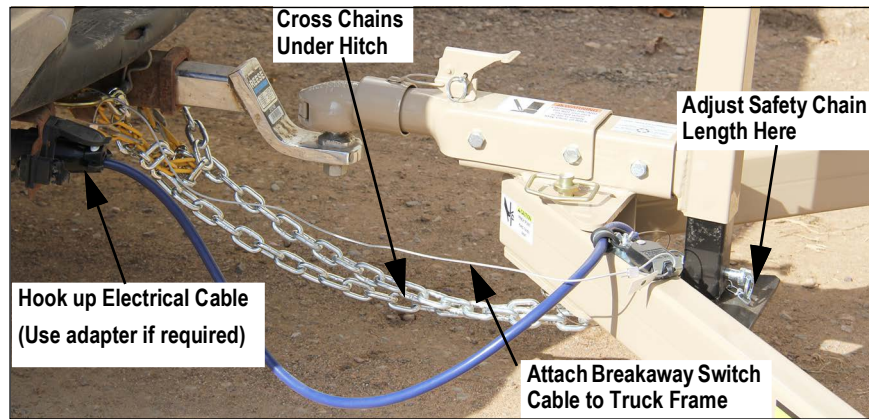

Figure 3-1. Hitch Connection

Safety chains must be connected during towing. Cross the chains under the hitch for proper protection. Safety chain length is adjustable by inserting the quick link through any link of the chain.

The scale must be connected electrically to the tow vehicle. Ensure that the wiring of the towing vehicle is compatible with the scale wiring before hooking up. The label on the hitch illustrates the wiring. See [Figure 2-9 on page 16](#) for wiring diagram. The scale is supplied with a 7-pin connector.

IMPORTANT: Ensure wiring is correct so the battery (which supplies power to the control box) is charged during transport.

WARNING: Improper wiring can cause brake failure.

If the scale is to be towed at night, or if the lights on the tow vehicle are obstructed by the scale, add-on lights are available. These lights plug into a 6-pin receptacle located on the rear of the battery box and attach magnetically to the scale frame. Contact Rice Lake Weighing Systems for more information.

WARNING: Scale is equipped with electric brakes. Brakes must be synchronized with the tow vehicle brakes before towing. See [Section 5.3.2 on page 29](#) for procedures.

The breakaway switch for the electric brakes must be connected during towing. This switch activates the scale brakes in the unlikely event of scale separation from the tow vehicle. The metal cable must be attached to a point on the tow vehicle other than the primary connection point.

The scale is designed to be towed at a ride height of approximately 8 in. A ride height label is attached to every shock absorber to visually confirm the ride height. After the scale is hooked up to the tow vehicle, check all the ride height labels to ensure proper air bag inflation. Add or remove air as necessary.

Suspension stops (one on each axle of the scale) are supplied to prevent the scale from dropping to the ground in the event of an air system failure. These stops must be in the transport position during towing.

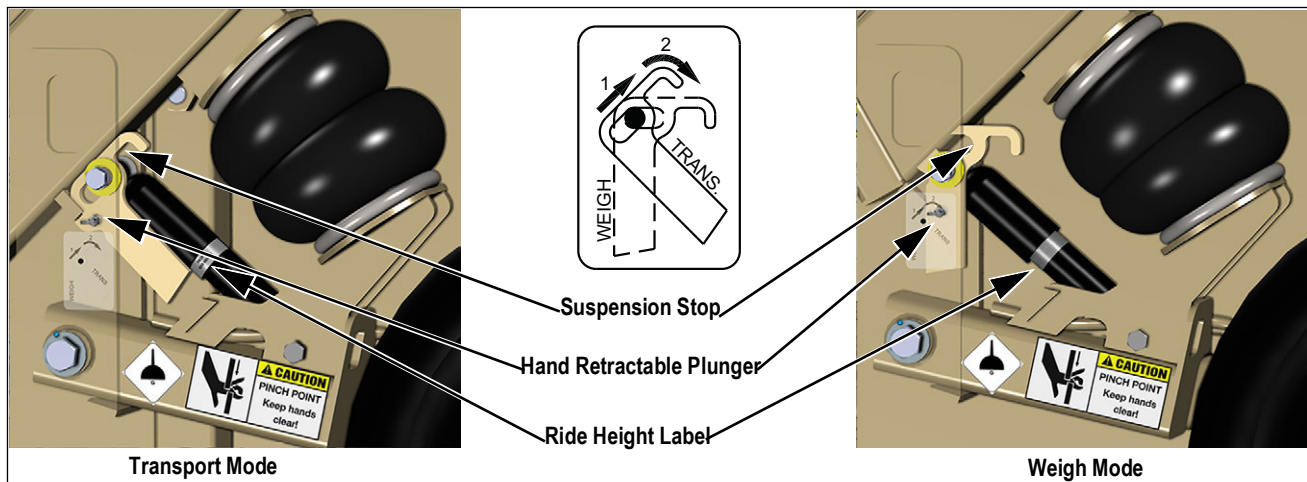

Figure 3-2. Suspension Stop and Ride Height

When in **Transport Mode**, rotate the suspension stop until the hand retractable plunger engages. To rotate back to **Weigh Mode**, pull the hand retractable plunger until the suspension stop is free from it.

WARNING: The Suspension Stops are not to be used as a means of transporting the scale. They are only to be used as a safety device, allowing removal of the scale from the roadway in the event of an air system failure.

3.1 Switching Modes

Use the following instructions to convert the scale into **Weigh Mode** or **Transport Mode**.

3.1.1 Converting to Weigh Mode

1. Park the scale in as level a location as possible. Ensure there are no obstructions under the deck that would affect weighing accuracy.

NOTE: The scale weighs properly on a slope up to a % (approximately 3% slope).

2. Turn the power switch (located in the weighcenter) to the ON position.
3. If the scale is not level the indicator will display **Out Of Level** with the pitch and roll angle below, allowing the scale to be leveled.
4. With the drop leg retracted, extend the jack until it begins lifting up on the scale hitch.
5. Disconnect the scale from the truck hitch and unplug all wiring.
6. Move the truck clear of the scale.
7. Lower the scale hitch to the ground using the hitch jack.
8. Flip the suspension stops (on each axle of the scale) into the **Weigh Mode**. Scale will not fully lower to ground with stops in transport position.
9. Ensure the dump valve (located on the battery box) is closed and open all valves located directly above the air bags.
10. Slowly open the dump valve to empty the air from the scale suspension. The scale will lower to the ground.
11. Inspect all four corners of the scale. Although the scale will weigh properly up to four degrees off level, individual corners of the scale should not be allowed to teeter. If any of the corners are not contacting the ground, either move the scale to a more level location or complete [Step 12 through Step 14 on page 20](#).
12. Close the dump valve and turn on the air pump to slightly raise the scale. Once the scale frame has lifted sufficiently, turn off the pump.

NOTE: If the air pump is not functioning, the scale can be raised using the auxiliary fill directly below the dump valve.

13. Place shims directly under the base frame, under the load cell stands, to prevent teetering.



Figure 3-3. Shimming Locations

14. Open the dump valves to lower the scale onto the ground and shims.
15. Unpin the hitch and swing both hitch halves clear.



NOTE: The hitch sections can be removed. To remove the hitch, remove the pins from the scale end of the hitch arms and pull all wiring through the driver's hitch tube.

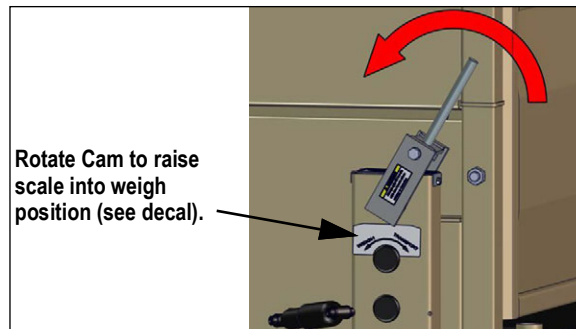

Figure 3-4. Scale Lift

16. Using both hands, raise the platform (rotate cam handle in direction indicated by decal) to enable the scale.



WARNING: The lift mechanism is an over center cam style lift and lock. If not disturbed, the scale remains locked in the up (weigh) position. Always grip lift handle with two hands when raising and lowering the scale.



NOTE: Cam levers point toward each other in Weigh Mode and away from each other in Transport Mode. See decals for direction of levers in each mode.

17. Ensure the weighcenter power switch is in the **ON** position. Verify the indicator does not show **Out Of Level**. If it does, shim the scale as necessary (Step 12 on page 19 – Step 14).
18. The weigh indicator should be powered up. The readout of **GROSS** weight on the indicator should be near zero (within 4% of the scale capacity). If it is not, ensure the scale is fully lifted and that there is no debris on or under the scale.



Figure 3-5. Scale in Weigh Mode

3.1.2 Converting to Transport Mode

1. Turn off the power switch located in the weighcenter. Close and latch the weighcenter cover.
2. Using both hands, lower the platform (rotate the cam handles in the direction indicated by decal) to disengage the scale. Ensure the handles are in the fully locked position.



WARNING: The lift mechanism is an over center cam style lift and lock. If not disturbed, the scale remains locked in the up (weigh) position. Always grip lift handle with two hands when raising and lowering the scale.



NOTE: Cam levers point toward each other in Weigh Mode and away from each other in transport. See decals for direction of levers in each mode.

3. Swing the hitch halves together, secure with the hitch pin and install the lynch pin.
4. Ensure the dump valve is closed.
5. Add air to the scale suspension so that the frame rises evenly off the ground to the correct ride height of approximately 8" (as indicated by the ride height labels on the shock absorbers). Use either the compressor on the scale or a remote compressor connected to the auxiliary air fill.

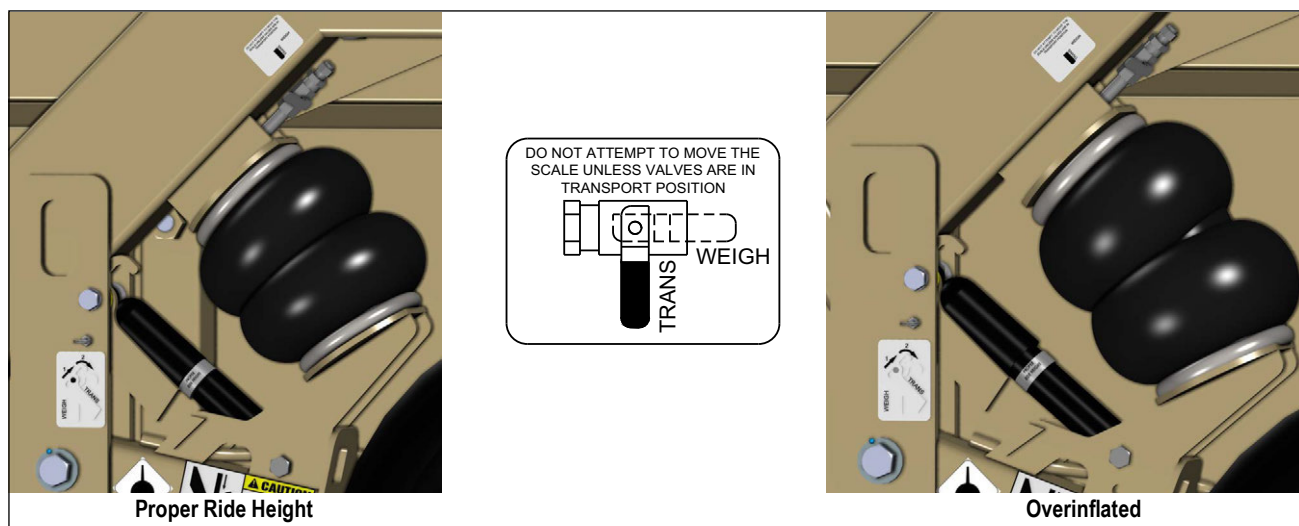

Figure 3-6. Scale Suspension

6. Close all the air valves. During scale towing, all valves must be closed.



NOTE: After connecting to the tow vehicle, the valves must be operated again.

7. Flip the suspension stops into the transport position.
8. Extend the jack so the scale hitch rises off the ground.
9. Position the truck near the scale hitch.
10. Connect the scale to the truck and connect all wiring.
11. Connect safety chains.
12. Connect equalizer hitch if desired.
13. Retract the jack.
14. Recheck the ride height of the scale and adjust as indicated on the ride height labels on the shock absorbers ([Step 5 on page 19](#)).



NOTE: For Tandem Axle Scales:

Once the scale is connected to the tow vehicle and the ride height has been set, close the dump valve and then open the valves on the front and rear axle to allow the pressure to equalize. Repeat for each side of the scale. Close the valves before transporting the scale.



WARNING: Do not move the vehicle until the scale is in the locked transport position, all air valves are closed, the jack is retracted and the drop leg pin is installed, the suspension stops are in transport position, and the safety chains are attached.

4.0 Repair Parts

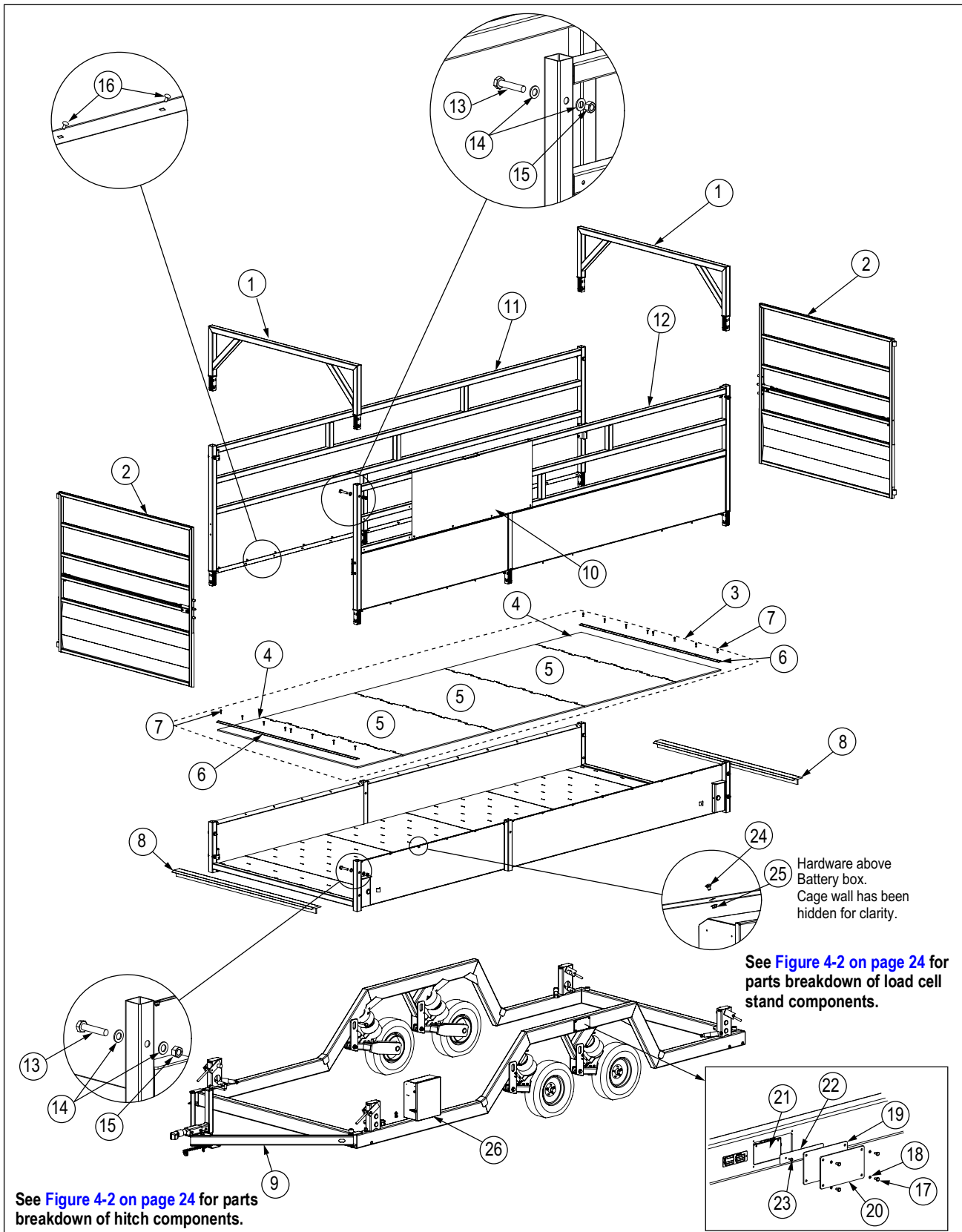

Figure 4-1. MAS-M Scale Parts Illustration

Item No.	Part No.	Description
1	130931	Cage Cross Member
2	131782	Gate, MAS (Figure 4-3 on page 26)
3	131992	Mat Installation Kit - 13 ft (Includes sealant, adhesive and Items 4-7)
	131993	Mat Installation Kit - 18 ft (Includes sealant, adhesive and Items 4-7)
	126775	Sealant, Silicone II Black 13 ft (Qty 2) / 18 ft (Qty 3)
	128280	Adhesive, Insta-Cure + 13 ft (Qty 5) / 18 ft (Qty 7)
4	127234	Matting, MAS End Section 13 ft (Qty 2)
	127236	Matting, MAS End Section 18 ft (Qty 2)
5	127235	Matting, MAS Center 13 ft (Qty 1) / 18 ft (Qty 3)
6	131855	Mounting Strip, Rubber (Qty 4)
7	127053	Bolt, Carriage 5/16-18 (Qty 16)
	21939	Washer, Plain 5/16 Type A (Qty 16)
	35170	Nut, Lock 5/16-18NC Hex (Qty 16)
8	126787	Scale T-Belting (83 in width)
	127271	Hold Down Loops
9	-	Hitch Assembly (Figure 4-2 on page 24)
10	130022	Operator Shield, Livestock
11	131708	Cage Wall 13 ft
	131946	Cage Wall 18 ft Right
12	131708	Cage Wall 13 ft
	131947	Cage Wall 18 ft Left
13	15099	Cap Screw, 3/4-10NC x 3-3/4 in
	15097	Cap Screw, 3/4-10NC x 3-1/2 in (18 ft Only - center bolts for walls)
14	15179	Washer, Plain 3/4 Type A
15	14697	Nut, Lock 3/4-10NC Hex
16	72083	Bolt Carriage 5/16 x 1/2 in Round Head Grade A Zinc
	14646	Nut 5/16 Flanged Serrated
	21939	Washer, Plain 5/16 Type A
17	127008	Screw, Cap 1/4-20 x 3/4 in
18	31546	Washer, Lock 1/4 Internal Tooth
19	126819	Foam Gasket Junction Box
20	127740	Cover Plate Scale Frame/Junction Box
21	88956	Scale Junction Box 4 Cell SS
22	131885	Mount Plate for Junction Box
23	121129	Screw 10-32 x 0.5 in
	14633	Nut, 10-32
24	126950	Nut, Flange 5/16-18 Case
25	158047	Bolt, Carriage 5/16-8 x 1/2 in
26	127721	Battery Box w/ compressor and wiring (Figure 4-5 on page 28)
-	131374	Paint, Touch-up

Table 4-1. MAS-M Scale Parts List



NOTE: Scale is only Legal for Trade with the optional 920i Weighcenter (PN 131436) installed. Contact a local scale dealer or Rice Lake Weighing Systems for more information.

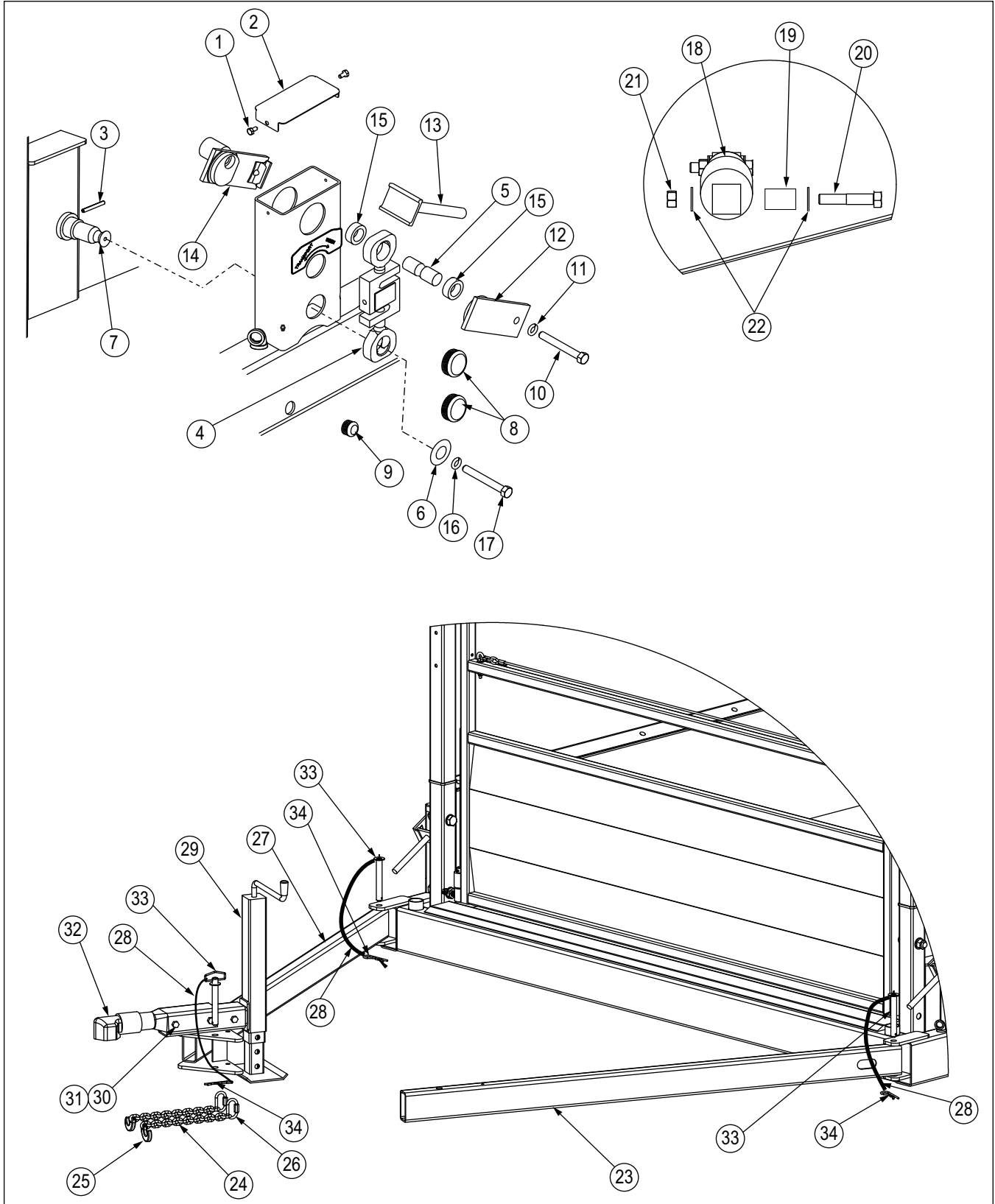

Figure 4-2. Hitch and Load Cell Stand Component Details

Item No.	Part No.	Description
1	127007	Cap Screw, 1/4-20 x 1/2 in
2	127200	Cover, Load Cell Cam Stand SS
3	126926	Pin Spring Slotted 1/4 x 2 1/4 in
4	127673	Load Cell Assembly S-Type 10K w/ Eye Bolts Installed w/ 20 ft Cable Includes Load Cells #2 through #4
	167452	Load Cell Assembly w/ Extended 40 ft Cable Load Cell #1 using 13 ft and 18 ft Cable
5	128184	Pin, Upper Notched Load Cell
6	174640	Retainer, Lower Load Cell
7	127177	Pin, Lower Notched Load Cell
8	126789	Plug Plastic Round 2 in
9	126788	Plug Plastic Round 1-1/8 in
10	14765	Bolt 1/2-13NC x 4 in
11	15167	Lock Washer 1/2 in
12	131785	Cam Lever without Lock Down - Right Rear
	127676	Cam Lever with Lock Down - Left Rear
13	127732	Cam Handle Mask
14	131787	Cam Lever with Lock Down - Left Front
	127675	Cam Lever without Lock Down - Right Front
15	127165	Spacer Upper Notched Pin
16	15154	Washer, Lock 5/16 in Regular
17	118020	Screw, Cap 5/16-18NC x 5/8 in
18	128626	Scale Damper Assembly w/ Rubber Bushings
19	126815	Bushing, Rubber 7/8 OD x 3/8 ID x 1.25 in long
20	22093	Cap Screw, 3/8-16NC x 2 in Hex
21	14656	Nut 3/8 HEX SS
22	15161	Flat washer 3/8 in SS SAE
23	131900	Hitch Tube Wldt, Left
24	131955	Chain Assembly, Grade 30 5/16 in (Includes items 25 & 26)
25	126917	Clevis Hook, 1/4 in Chain
26	126967	Link, Quick, 5/16 in
27	131896	Hitch Tube, Right
28	166326	Lanyard, 1/16Ø x 12 in
29	127716	Jack w/ Drop Leg and Mount
30	14765	Bolt, 1/2-13NC x 4 in Hex Head
31	14660	Nut, Lock 1/2-13NC Hex
32	127715	Hitch Coupler Mobile MAS, 5000 lb
33	160257	Hitch Pin, 3/4 in x 5 1/4 in (Includes item 34)
34	160258	Lynch Pin, 3/16 x 1 1/4 in (Replacement sold separately)

Table 4-2. Hitch and Load Cell Stand Components Parts List

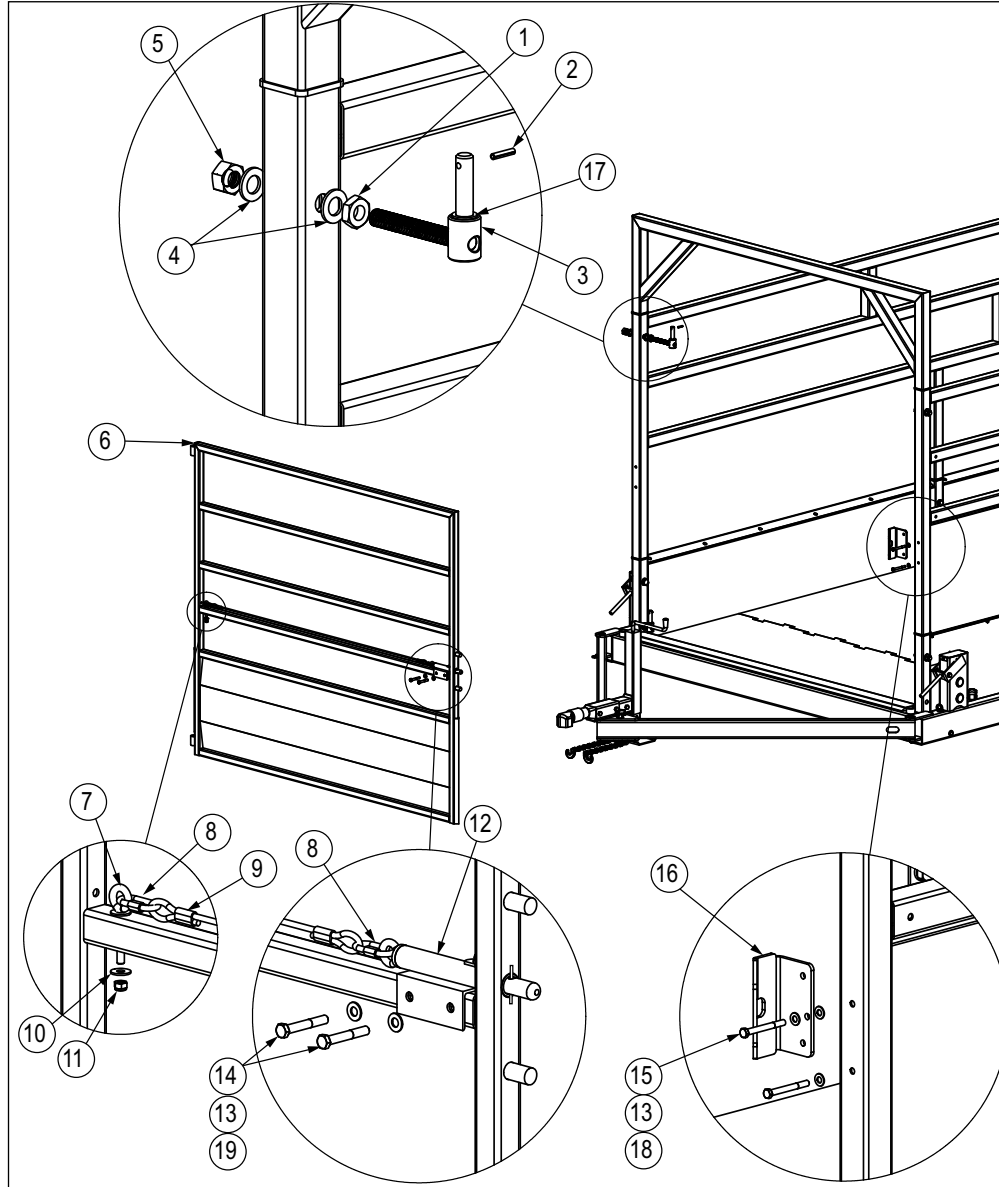

Figure 4-3. Gate Component Details

Item No.	Part No.	Description
1	132217	Jam Nut, 3/4-10NC
2	110950	Pin, Spring 1/4 x 1 1/4
3	165944	Hinge Bolt
4	15179	Washer, 3/4 Type A Steel
5	111074	Nut, 3/4-10NC
6	131782	Gate, MAS
7	131701	Eye Bolt, 5/16-18 x 2 1/2
8	131887	Quick Link 1/4 in
9	131886	Cable, 1/4 in OD x 6 ft
10	21939	Washer, 5/16
11	14646	Nut, Lock 5/16-18NC

Item No.	Part No.	Description
12	131784	Gate Latch Assembly
	131702	Spring, Compression #44
	160302	Hairpin, 0.08 x 1 9/16
13	21938	Washer, 3/8 Lock
14	151559	Cap Screw, 3/8-16NC x 2 1/2 Hex Head
15	151560	Cap Screw, 3/8-16 x 3 1/2 Hex Head
16	155916	Strike Plate, Gate Latch
17	151807	Washer, Plain 3/4 in Nylon
18	22072	Nut, 3/8-16 Grade5
19	132684	Nut, Hex 3/8-16NC Gr5 Zinc

Table 4-3. Gate Component Details

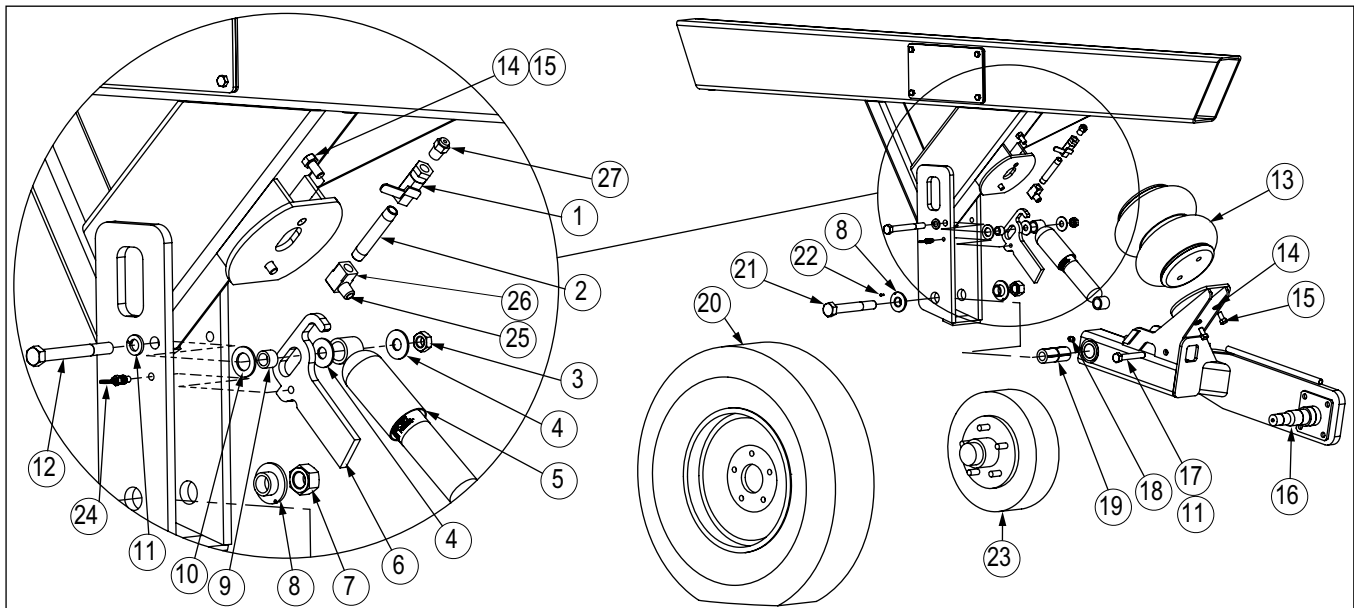

Figure 4-4. Tire/Wheel Parts

Item No.	Part No.	Description
1	127069	Ball Valve, Miniature
2	82133	Nipple, Pipe 1/4NPT x 3 in
3	126936	Nut Jam 1/2-13NC HEX
4	127046	Washer 7/16 in USS
5	127745	Suspension Shock Absorber
6	127334	Suspension Stop Arm
7	14697	Nut Lock Nylon 3/4 in
8	Consult	Bushing, Alignment Mast SS 131903-2 131904-2 131905-2 131906-2 131907-2 131908-2 14697-2 160767-1 76832-1 14906-1
9	127178	Bushing Suspension Stop
10	151422	Washer 3/4 SAE
11	15167	Lock washer 1/2 in
12	14768	Bolt 1/2 x 4-1/2 in
13	164910	Airbag Suspension Type Firestone Style 26
14	15159	Washer, Lock 3/8 in Regular
15	114028	Screw, Cap 3/8-16 NC x 3/4 in
16	127718	Axle Arm Left (Driver's Side)
	127719	Axle Arm Right (Passenger's Side)

Item No.	Part No.	Description
17	127035	Bolt 1/2-13 x 3-1/4 in Hex Head
	126991	Nut 1/2-13NC Grade 5 Hex Head
18	126812	Nipple, Grease 1/8 in
19	160676	Bushing Pivot Axle
20	161359	Tire and Rim ST175/80R13
21	76832	Bolt 3/4 x 6 1/2 om Grade 5
22	14906	Screw, Drive NO 4 x 3/8 in
23	132389	Hub and Drum, 3500# Axle
24	174218	Hand Retractable Plunger, Safety Stop
25	127070	Fitting, Air 1/4NPT x 1 1/8 Long, OAL Brass
26	126913	Fitting, 90° Elbow, 1/4NPT Female MAS Air Break System
27	126902	Fitting, Straight 1/4 NPT
NS	127728	Kit, Brake Wiring Cable, Single Tandem
NS	127729	Kit, Brake Wiring Cable, Dual Tandem
NS	132387	Brake Assembly, Left (Driver's Side)
NS	132388	Brake Assembly, Right (Passenger's Side)
NS	160491	Dust Cap for Hub
NS	160492	Rubber Seal

Table 4-4. Tire/Wheel Parts

Item No.	Part No.	Description
1	127069	Ball Valve, Miniature
2	82133	Nipple, Pipe 1/4NPT x 3 in
25	127070	Fitting, Air 1/4NPT x 1 1/8 Long, OAL Brass
26	126913	Fitting, 90° Elbow, 1/4NPT Female MAS Air Break System
27	126902	Fitting, Straight 1/4 NPT
NS	126903	Air Line, Type 3A Brake

Item No.	Part No.	Description
NS	126905	Fitting, Union Tee J844D
NS	126919	Grommet, 5/16 ID x 3/16
NS	15020	Screw, Cap 3/8-16 NCx1 HEX
NS	15160	Washer, Lock 3/8 Regular
NS	127731	Airbag Kit for Tandem Axle
NS	127730	Airbag Kit for Single Axle

Table 4-5. Airbag Kit (PN 127731) for Tandem Axle

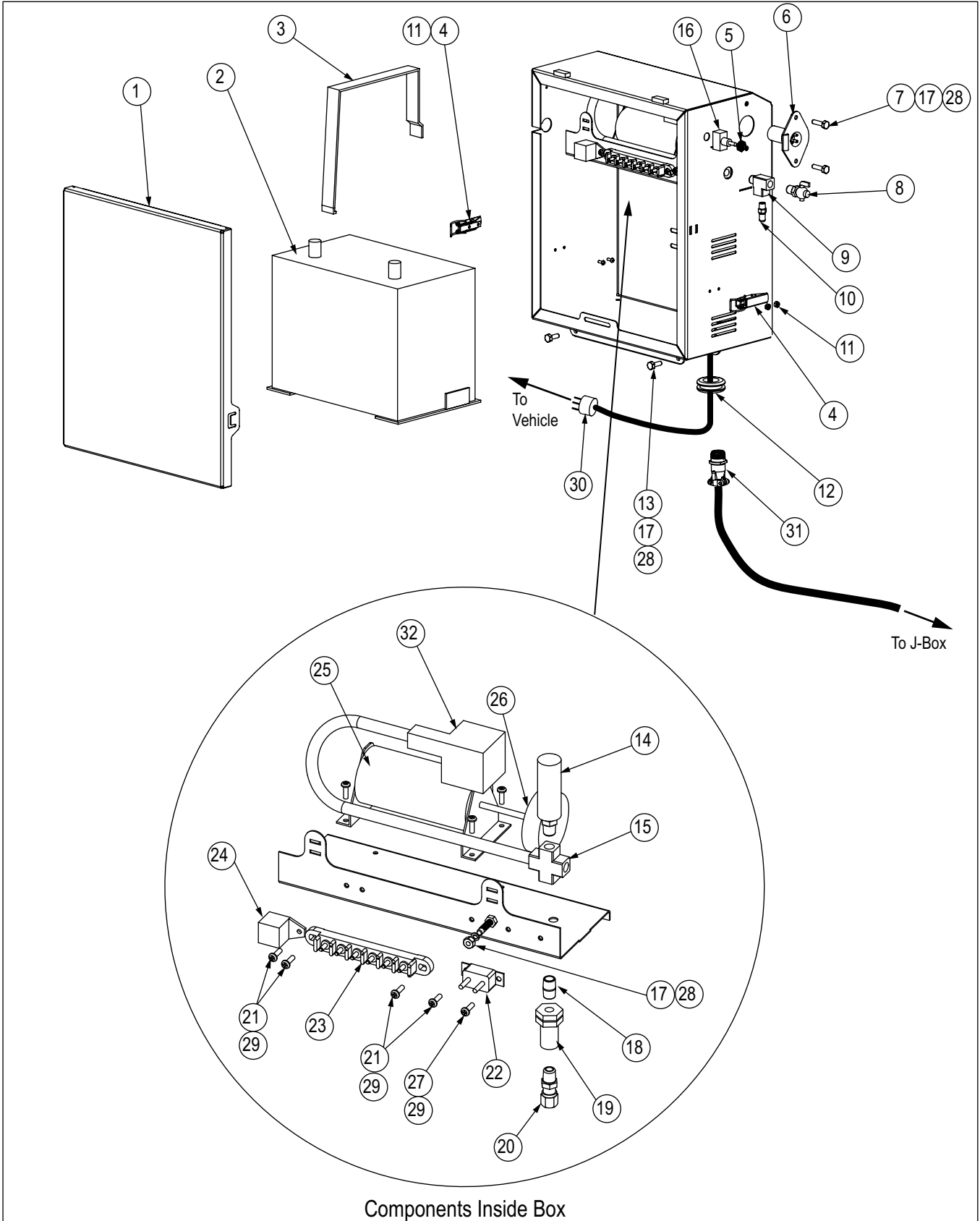

Components Inside Box

Figure 4-5. Battery Box Parts

Item No.	Part No.	Description
1	127720	Door Assembly Battery Box, 2017 and earlier
	189521	Door Assembly Battery Box, 2018 and later
2	127106	Battery Deep Cycle Marine
3	127073	Strap 1 in with Clasp
4	171522	Latch SS Pull Up
	160302	Hair Pin, 0.080 x 1 9/16
5	128108	Switch, Hex Seal Toggle
6	127393	Connector, Brake 6 Way
7	127007	Screw, Cap 1/4-20 x 1 Hex
8	126891	Valve Brass Drain Cock
9	126909	Fitting, Street Tee 1/4 NPT
10	126899	Fitting, Brass, Air Brake, Synflex to 1/4 MP
	127399	Valve, Air Tank, 1/8NPT
11	60768	Screw, Machine 6-32 x 3/8
	153887	Washer, M4 Flat Zinc
	14625	Nut, Lock 6-32NC Hex Nylon
12	126944	Grommet 1-3/8 x 1/4
13	133012	Screw, Cap 1/4-20 x 3 3/4
14	127406	Relief Valve Air 150 PSI
15	126900	4FP Brass Cross
16	127398	Switch ON/OFF
17	14641	Nut, Hex 1/4-20NC Steel
18	45370	Nipple, Close Pipe Brass
19	126901	Fitting Brass 4FP Terminal Bolt
20	126902	Fitting Brass 4MP to ¼ Synflex
21	127020	Screw, Machine 10-32 x 5/8
22	127076	Circuit Breaker 12V 30 Amp
23	127402	Terminal Block, 6 Steel
24	197295	Headlight Relay, 12V 40A
25	127414	Air Compressor 12V, 1 CFM (Includes item 32)
26	151681	Air Filter, 12V Compressor
27	59937	Screw, Mach Pan Head
28	31546	Washer, Lock 1/4 Internal Tooth
29	126956	Nut, Lock 10-32NC Grade 2
30	127727	Cable Assembly, Scale to Vehicle
31	127562	Cable Assembly, 4 Pin Female
32	151681	Air Filter, Remote Mount (Included with item 25, replacement for air filter only)

Table 4-6. Battery Box Parts

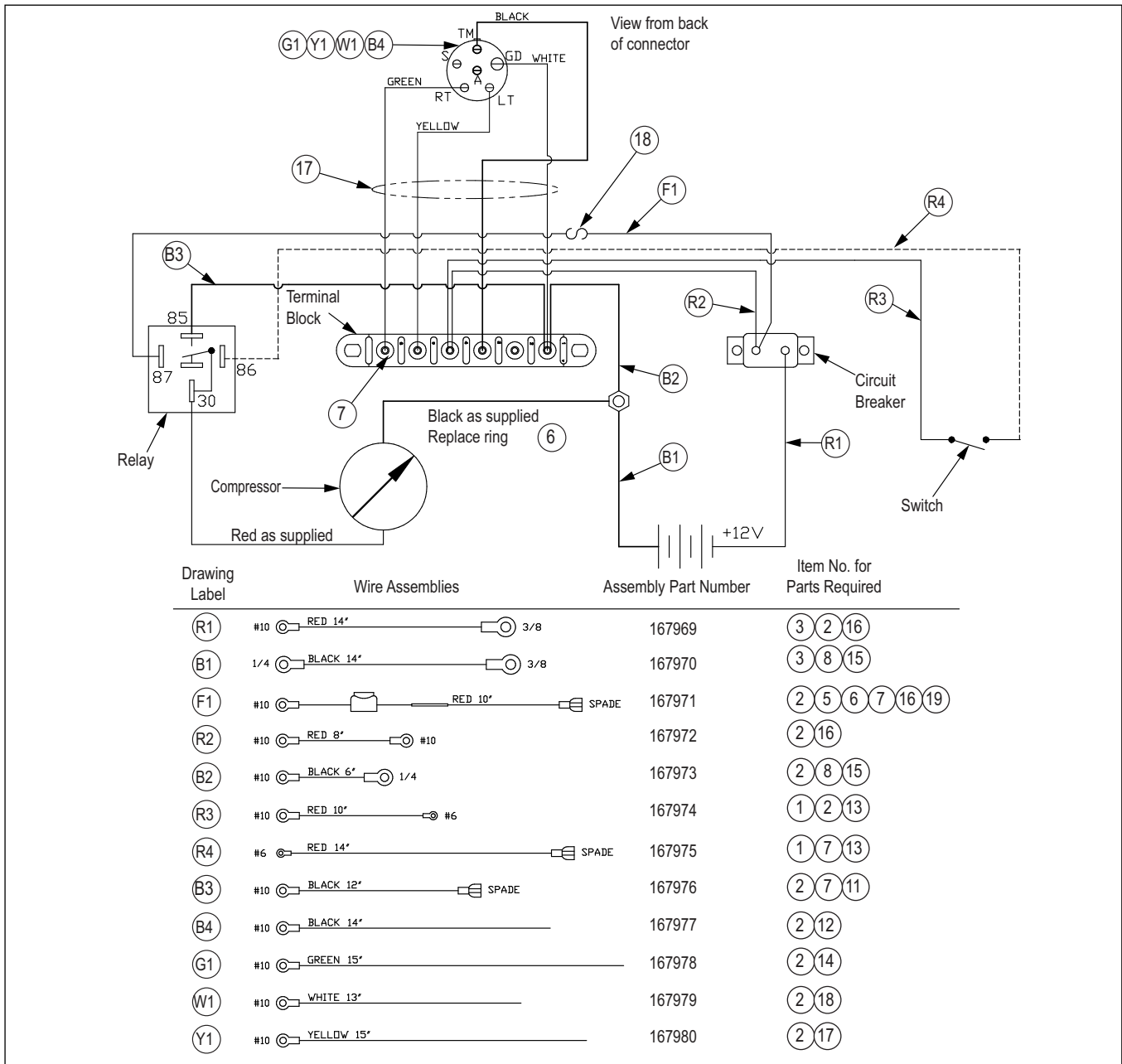

Figure 4-6. Battery Box Wiring Parts Illustration

Item No.	Part No.	Description
1	126918	Terminal Ring, No. 6 Stud
3	127039	Terminal Ring, 3/8 in
5	127074	Fuse Holder, 20 AMP
6	127395	Fuse, 20 AMP for Battery
7	31218	Terminal, 1/4 in Female
8	128128	Terminal Ring, 1/4 in stud
9	128778	Washer, Lock Tooth No 10
11	15431	Wire, 18AWG Black Stranded
12	15432	Wire, 18AWG Brown Stranded

Item No.	Part No.	Description
13	15433	Wire, 18AWG Red Stranded
14	15434	Wire, 18AWG Green Stranded
15	15443	Wire, 14AWG Copper Strand
16	15444	Wire, 14AWG Copper Strand
17	15451	Wire, 18AWG Yellow
18	15454	Wire, 18AWG White Stranded
19	15643	Tubing, Heat Shrink 1/4 in
20	16141	Cable Tie, 8 in Nylon
21	126870	Fuse, Blade 7.5A 32V ATO

Table 4-7. Battery Box Wiring Parts List

5.0 Maintenance

5.1 Maintenance Schedule

Before Each Use

Grease axle pivot locations with the provided grease zerks (Figure 5-1) using a Black Moly type grease.

First Week

Check torque on all wheel nuts (Table 2-1 on page 11).

Weekly

1. Check entire scale for buildup of debris. Remove any debris found on, under or around the scale. Rubber T-belting at both ends of the scale are removable to make cleaning out easier. To remove T-belting, unhook the stretch cord that hooks into the corner tube of the cage.
2. Check for dirt and debris in the load cell stands and clean accordingly.
3. Check all external cables and conduit for damage.

First Month (In Addition to Weekly Maintenance)

1. Check torque on all wheel nuts (Table 2-1 on page 11).
2. Adjust scale brakes.

Monthly (In Addition to Weekly Maintenance)

1. Charge scale battery if necessary.
2. Tire Pressure. 45 psi./40 psi. - Single /Tandem Axle
3. Grease gate latch zerks (Figure 5-1) using a Black Moly type grease.

Yearly (In Addition to Weekly and Monthly Maintenance)

1. Check and grease wheel bearings (Section 5.4.1 on page 34).
2. Disassemble each load cell location and grease all pins and eye bolts (Section 5.2.2 on page 32).
3. Adjust scale brakes (Section 5.3.3 on page 33).

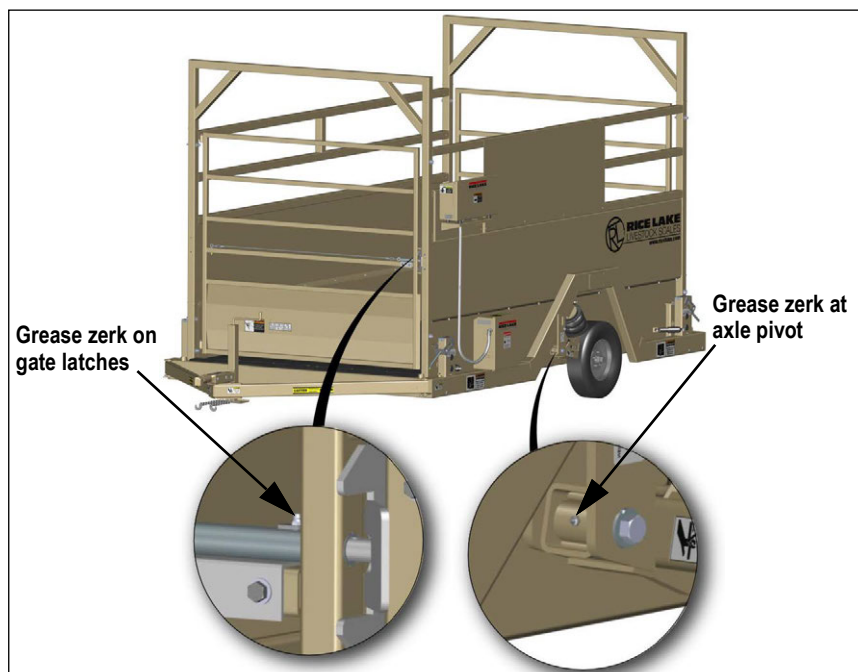

Figure 5-1. Grease Zerk Locations

5.2 Scale Maintenance Procedures

5.2.1 Cleaning Load Cell Stands



IMPORTANT: Keep any excess debris from building up in the load cell stand.

Lift scale and block it up, then clean any dirt out of the load cell stands through the drain holes at the bottom of the stand.

5.2.2 Disassembly and Greasing

Greasing the scale is very important to ensure the long life of the unit. Use the parts list drawings for item numbers.



NOTE: Use quality high-pressure grease.

Avoid bending or twisting the load cell wires.

1. Remove the cell stand cover.
2. Remove the plug covers.
3. Remove the bolt holding the outer cam, load cell pin and inner cam together.
4. While holding the cam handle, remove the outer cam.
5. Remove the load cell pin and spacers. The load cell assembly will be free on top and rest against the inside of the load cell stand.
6. Remove the inner cam.
7. Remove the lower retainer.
8. Grease all bearing surfaces except where the eye bolt contacts the pin (upper and lower pins, cams, upper and lower eye bolts).
9. Reassemble in reverse order as described above.

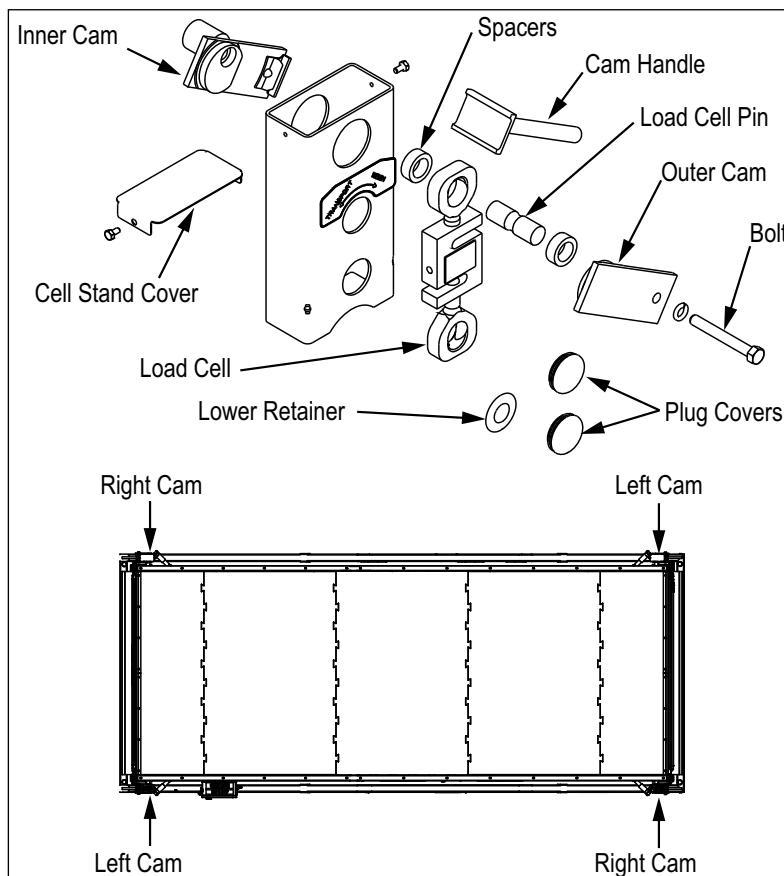

Figure 5-2. Disassembly and Greasing

5.3 Brake Maintenance

5.3.1 How to Use The Electric Brakes Properly

The scale brakes are designed to work in synchronization with the tow vehicle brakes. Never use the tow vehicle or scale brakes alone to stop the combined load.

The brake controller must be set up according to the manufacturer's recommendations to ensure proper synchronization between the tow vehicle and the scale. Additionally, small adjustments may need to be made to accommodate changing loads and driving conditions.

Proper synchronization of tow vehicle to scale braking can only be accomplished by road testing. Brake lockup, grabbing, or harshness is often due to the lack of synchronization between the tow vehicle and the scale being towed, too high of a threshold voltage (over 2 V), or under adjusted brakes.



WARNING: *The following should only be performed in a safe environment, such as an unpopulated road free of traffic or under controlled conditions.*

Before any synchronization adjustments are made, the scale brakes should be burnished-in by applying the brakes 20-30 times with approximately a 20 mph decrease in speed, e.g., 40 mph to 20 mph. Allow ample time for brakes to cool between application. This allows the brake shoes and magnets to slightly wear-in to the drum surfaces.

5.3.2 Synchronizing The Scale Brakes

To ensure safe brake performance and synchronization, read the brake controller manufacturer's instructions completely before attempting any synchronization procedure.

Make several hard stops from 20 mph on a dry paved road free of sand and gravel. If the scale brakes lock and slide, decrease the gain setting on the controller. If they do not slide, slightly increase the gain setting. Adjust the controller just to the point of impending brake lockup and wheel skid.



NOTE: *Not all scale brakes are capable of wheel lockup. Loading conditions, brake type and wheel and tire size can all affect whether a brake can lock. It is not considered desirable to lock up the brakes and slide the tires. This can cause unwanted flat spotting of the tires and could also result in a loss of control.*

If the controller is applying the scale brakes before the tow vehicle brakes, then the controller adjustments should be made so the scale brakes come on in synchronization with the tow vehicle brakes. For proper braking performance, it is recommended that the controller be adjusted to allow the scale brakes to come on just slightly ahead of the tow vehicle brakes. When proper synchronization is achieved there will be no sensation of the scale jerking or pushing the tow vehicle during braking.

5.3.3 Brake Adjustment

Brakes should be adjusted:

- After the first 200 miles (first month) of operation when the brake shoes and drums have seated
- At 3,000 mile intervals (or yearly)
- Or as use and performance requires

Brakes should be adjusted in the following manner:

1. Jack or block the axle arm to allow free rotation of the wheel.
2. Remove the adjusting hole cover from the adjusting slot on the bottom of the brake backing plate.
3. Rotate the star wheel of adjuster assembly with a screwdriver or standard adjusting tool to expand the brake shoes. Adjust the brake shoes out until the pressure of the linings against the drum makes the wheel very difficult to turn.
4. Rotate the star wheel in the opposite direction until the wheel turns freely with a slight lining drag.
5. Replace the adjusting hole cover and lower the wheel to the ground.
6. Repeat the above procedure on all brakes. For best results the brakes should all be set at the same clearance.

5.4 Hubs, Drums and Bearings Maintenance



WARNING: To prevent damage to important structural components, all maintenance procedures must be followed. Damage to structural components can cause the wheel end to come off the axle, which can lead to loss of control.

5.4.1 Bearing Adjustment

1. After placing the hub, bearings, washers, and spindle nut on the axle spindle, rotate the hub assembly slowly while tightening the spindle nut to approximately 50 ft-lb.
2. Loosen the spindle nut to remove the torque. Do not rotate the hub.
3. Finger tighten the spindle nut until snug.
4. Align the retainer to the machined flat on the spindle and press the retainer onto the nut until it snaps into place. The retainer/nut should be free to move slightly.



NOTE: If retainer/nut assembly does not move slightly, remove the retainer and loosen the nut about 1/12 of a turn. Reinstall the retainer. The assembly should now move slightly.

5. Install the dust cover and rotate the wheel to ensure the cotter key does not contact the dust cover.

5.4.2 Lubricate Hubs

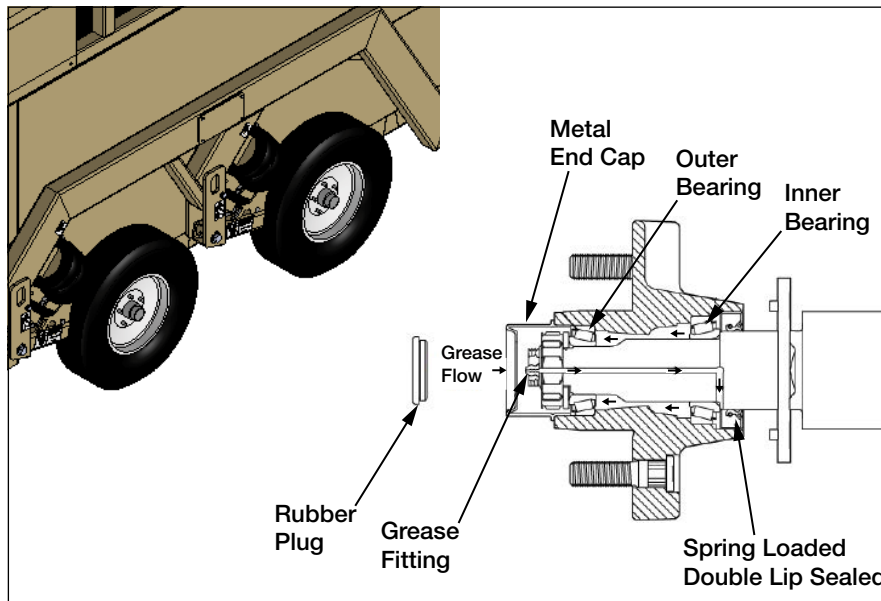

Figure 5-3. Hub Lubrication

1. Remove the rubber plug from the end of the grease cap.
2. Place a standard manual grease gun on the grease zerk in the end of the spindle.



IMPORTANT: A high temperature, wheel bearing grease is required. Do not use a pneumatic powered grease gun (it injects grease too fast and forces grease past the seal) or dislodge the seal.

3. Pump grease slowly into the fitting while rotating the hub. The old grease will flow out of the cap around the grease gun nozzle.
4. Once the grease coming out is the new clean grease, remove the grease gun.
5. Wipe off excess grease and replace the rubber plug.



IMPORTANT: If hubs are removed from an axle, seals must be replaced prior to bearing lubrication. If not replaced, grease may get on the brake linings.

5.5 Gathering Panel Attachment

Suggested Construction

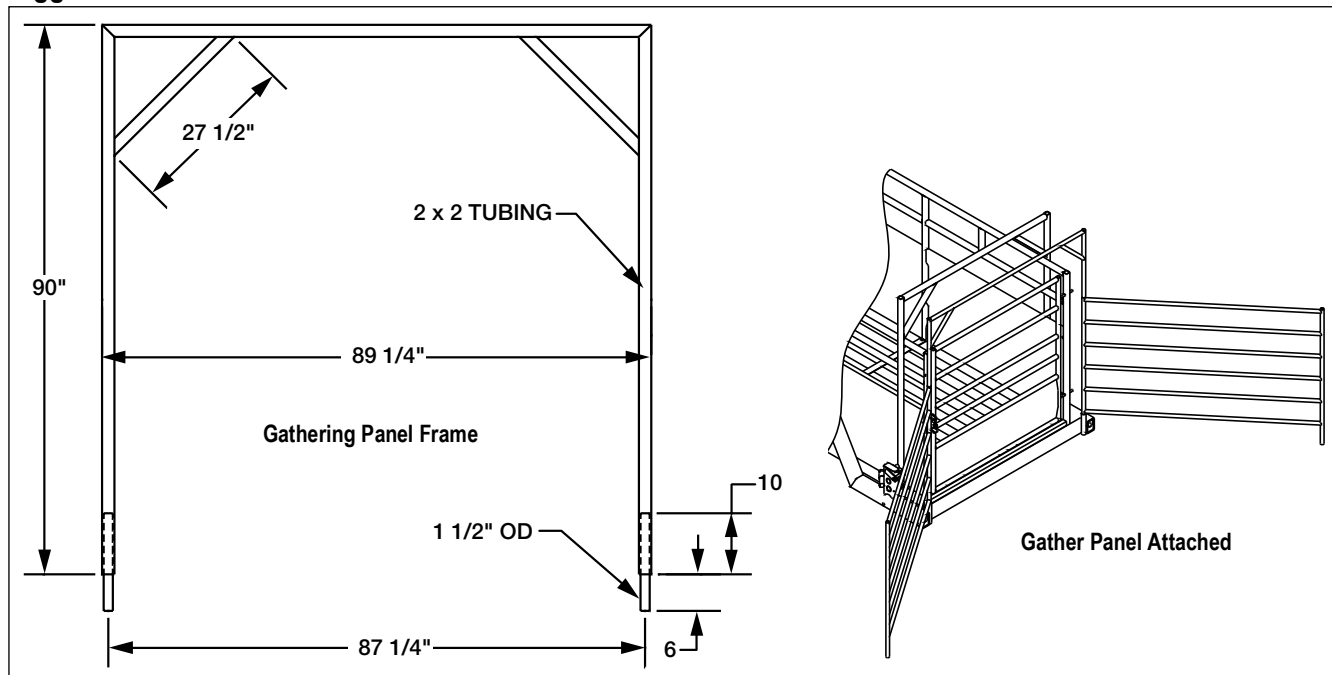

Figure 5-4. Gathering Panel Attachment

Building a simple framework that can be set into the provided scale posts can accommodate the mounting of almost any panel. In some cases, extra support of the mounting frame may be required.

Figure 5-4 shows the suggested construction of a framework that can be built to support the type of gathering panels available. Some gathering panels can be set directly into the corner posts, or located on the corners of the scale. The drawing above that can be set into the top of the panels serves as an example. With the wide variety of panels and configurations available, we cannot provide a mounting means for all of them.

However the scale is mounted, make sure the panels or framework are not attached to the scale cage. There must be a clearance of 1 in from any live portion of the scale. Any contact between the panels or framework and the scale can cause the weight reading to be inaccurate.



CAUTION: *Gathering panels or handling attachments must be removed from the scale during transport.*

The scale is not intended for the transportation of goods or livestock. Using the scale to transport goods or livestock voids the warranty.

5.6 Troubleshooting

Symptom	Probable Cause	Action
The scale indicator will not power up	Blown in-line fuse	Replace in-line fuse, the fuse holder is located near the battery or the indicator
	Voltage is less than 11 V	Repair faulty electrical system; The panel requires at least 11 V to operate properly
Indicator turns off or resets in the middle of a transaction	Low voltage to control panel	Check other electrical equipment that may be operating; Check for corrosion or damaged wiring; Measure voltage
Weight reading on indicator is unstable	The circuit board in the control panel may be wet or the junction box for the load cells may have moisture	Dry any areas that are contaminated with moisture; Check for leaks and reseal
	A load cell cable may be pinched or damaged	Contact Rice Lake Weighing Systems or a qualified dealer for support; Cutting the load cell cable will void the warranty; Special repair techniques are required
Scale has a positive error when loading or a negative error when unloading	Mechanical binding problem on scale	Check for debris around or under the scale; Check each load cell location for foreign material; Check all items that run from on the scale to off the scale; Check all gates or gathering panels for contact
Scale has a negative error when loading or a positive error when unloading	Moisture is present somewhere in the electrical system	Dry any areas that are contaminated with moisture; Check for leaks and reseal
Printer is not functioning – nothing is being printed at all	Is the release light on the printer flashing? This could indicate a low voltage to printer	The system requires at least 11 V to operate properly; Your truck may need to be running to supply enough power or the truck may have a faulty electrical system
	The print head may be jammed with paper	Remove the print head cover and ribbon; Check for bits of paper stuck in the paper feed mechanism
	The print head may be packed with dirt from operating in dusty conditions	Remove the print head cover and ribbon; Blow out with air; If the printer is very dirty it may require service by a qualified technician
The printer is printing unrecognizable characters	The power supply is excessively noisy	Contact Rice Lake Weighing Systems, an in-line power filter may be necessary
	Incorrect dip switch settings	Settings are 1,7,8 ON rest OFF
The printing on the ticket is faint or hard to read	The printer's ink ribbon may need to be replaced	Replace ribbon
	The printer head may be damaged	Requires service by a qualified technician
Scale will not ZERO	Weight on scale larger than the allowable ZERO window	Clean the scale deck of debris, then ZERO the scale
Compressor runs continuously and air flow is lower than normal	Loose connections	Check all connections, tighten loose connections
	Worn piston ring or inlet valve	Replace compressor
	Clogged air filter element	Replace air filter element

Table 5-1. Troubleshooting



IMPORTANT: If a problem with the scale is suspected, contact Rice Lake Weighing Systems or a qualified local scale dealer.

5.7 Towing Checklist

Review each item of the checklist at delivery; checklist should be signed by both the dealer and the customer.

- Operator safety section of manual has been reviewed.
- Scale is not intended for the transport of livestock or any other goods or materials.
- Ball on towing vehicle must be 2 in.
- Hitch height of towing vehicle must be between approximately 16 in above the ground such that the scale is in towing level.
- Safety chains must always be connected during towing.
- Towing vehicle must be wired correctly (see label on hitch).
- Magnetic lighting package must be on the scale during towing.
- Scale is equipped with electric brakes and must be synchronized. See synchronization procedure in manual.
- Scale is designed to be towed at a ride height indicated by labels on the suspension shock absorbers. Towing at ride heights outside of the indicated range may result in suspension damage.
- Suspension stops must be in the transport position during towing.
- Converting the scale from **Weigh Mode** to **Transport Mode** and back to **Weigh Mode** has been reviewed.
- Safety pins are installed in all the hitch pins.
- RLWS recommends re-torquing wheel lug nuts at 10, 25 and 50 miles.

Customer Date:

Dealer Serial Number:

Copy to be retained by dealworder

Fax copy to manufacturer: Fax #: 715-234-6967

6.0 Specifications

Size / Model # _____

Serial # _____

Date Purchased _____

Unit ID # _____

Specification	MAS-M 8-13	MAS-M 8-18
Length Overall	18 ft - 8 in	24 ft - 5 in
Length Deck	12 ft - 5 in	18 ft - 2 in
Width Overall	8 ft - 6 in	8 ft - 6 in
Width Deck	7 ft - 5 in	7 ft - 5 in
Deck Height	6 in	6 in
Height	109 in	109 in
Deck Covering	5/8 in Recycled Rubber Flooring System	
Weight	3480 lb	4730 lb
Capacity	15000 lb	20000 lb
Approval Class	IIIL (IIHHD)	IIIL (IIHHD)
Approvals	 99-091	Measurement Canada Approved AM4847
Grad Size	5 lb (2 kg)	5 lb (2 kg)
Paint	Powder Coated	
Tire Pressure	50 PSI	45 PSI
Wheel Size	13 ft 5 on 4.5 in	13 ft 5 on 4.5 in
Tire Size	ST175/80D13	ST175/80D13
Lug Torque	90-120 ft-lb	90-120 ft-lb
Battery	12 V Deep Cycle	12 V Deep Cycle
**Structural Steel is not galvanized.		

Table 6-1. Specifications



© Rice Lake Weighing Systems Content subject to change without notice.

230 W. Coleman St. • Rice Lake, WI 54868 • USA USA: 800-472-6703 • International: +1-715-234-9171