

Multiple Animal Scale – Portable

MAS-P

Installation Manual



© Rice Lake Weighing Systems. All rights reserved.

Rice Lake Weighing Systems® is a registered trademark of
Rice Lake Weighing Systems.

All other brand or product names within this publication are trademarks or
registered trademarks of their respective companies.

All information contained within this publication is, to the best of our knowledge, complete and
accurate at the time of publication. Rice Lake Weighing Systems reserves the right to make
changes to the technology, features, specifications and design of the equipment without notice.

The most current version of this publication, software, firmware and all other product
updates can be found on our website:

www.ricelake.com

Revision History

This section tracks and describes manual revisions for awareness of major updates.

Revision	Date	Description
I	December 4, 2028	—
J	July 26, 2024	Established revision history; updated replacement parts

Table i. Revision Letter History



Technical training seminars are available through Rice Lake Weighing Systems. Course descriptions and dates can be viewed at www.ricelake.com/training or obtained by calling 715-234-9171 and asking for the training department.

Contents

1.0	Introduction	5
1.1	Overview	5
1.2	Safety	6
1.2.1	Animal Safety	6
1.2.2	Calibration	6
1.2.3	Safety Decals	7
1.3	Unloading	9
1.3.1	Slings the Scale	9
1.3.2	Lift the Scale	9
1.3.3	Remove Lifting Fixture	9
1.4	Lifting Assembled Scale	10
1.5	Indicator Package Removal	10
2.0	Installation	11
2.1	Permanent Installation	11
2.2	Portable Installation	11
2.3	Switching Modes	11
2.3.1	Convert to Weigh Mode	11
2.3.2	Convert to Transport Mode	12
2.4	Cage Wall Assembly	12
2.4.1	Apply the Silicone Bead	12
2.4.2	Install Walls	13
2.4.3	Install the Gate	13
2.5	Gate and Latch Adjustment Procedure	14
2.6	T-Belt	14
2.7	Optional 920i Weighcenter Mounting	15
2.8	Optional AC/DC Power Supply Adapter Box Kit	15
2.8.1	Mounting to Scale	16
2.9	Wiring the Scale	18
2.10	Battery Box Connections	19
2.11	Load Cell Wiring Diagrams	19
3.0	Repair Parts	20
4.0	Maintenance	26
4.1	Maintenance Schedule	26
4.2	Scale Maintenance Procedures	26
4.3	Troubleshooting	27
4.4	Specifications	28



Rice Lake continually offers web-based video training on a growing selection of product-related topics at no cost. Visit www.ricelake.com/webinars

1.0 Introduction

The Multiple Animal Scale – Portable (MAS-P) system is manufactured with top quality components. It is engineered using the latest technology to provide operating features and reliability unmatched for years to come.

Please take the time to read this manual completely before attempting to use the system. Although the MAS-P has been designed for easy setup and use, a thorough understanding of this manual will ensure that the user receives the maximum benefit from the system.

Please contact Rice Lake Weighing Systems at 800-472-6703 with any questions or concerns.



Manuals are available from Rice Lake Weighing Systems at www.ricelake.com/manuals

Warranty information is available at www.ricelake.com/warranties

1.1 Overview

The MAS-P consists of a sheeted animal cage suspended by four S-type load cells through a cam style on-board lift system that sits on top of a portable base frame. In transport mode, the scale system is locked down, protecting the load cells from damage during transport. The scale is raised to the weigh mode using a lever and cam system. A digital indicator is connected to the scale to display the weight.

The MAS-P can be used on any firm surface up to a 6% grade (3° slope) and has a low deck height (6") for easy step in.



Figure 1-1. MAS-P Animal Scale

1.2 Safety

Safety Definitions:



DANGER: Indicates an imminently hazardous situation that, if not avoided, will result in death or serious injury. Includes hazards that are exposed when guards are removed.



WARNING: Indicates a potentially hazardous situation that, if not avoided, could result in serious injury or death. Includes hazards that are exposed when guards are removed.



CAUTION: Indicates a potentially hazardous situation that, if not avoided, could result in minor or moderate injury.



IMPORTANT: Indicates information about procedures that, if not observed, could result in damage to equipment or corruption to and loss of data.

General Safety



Do not operate or work on this equipment unless this manual has been read and all instructions are understood. Failure to follow the instructions or heed the warnings could result in injury or death. Contact any Rice Lake Weighing Systems dealer for replacement manuals.



WARNING

Failure to heed could result in serious injury or death.

Do not allow minors (children) or inexperienced persons to operate this unit.

Do not operate without all shields and guards in place.

Do not use for purposes other than weighing.

Do not place fingers into slots or possible pinch points.

Do not place hands, feet or any body part underneath the scale at any time. The scale could be lowered, crushing body parts.

Do not use any load bearing component that is worn beyond 5% of the original dimension.

Do not use this product if any of the components are cracked.

Do not exceed the rated load limit of the unit.

Do not make alterations or modifications to the unit.

Do not remove or obscure warning labels.

Keep hands, feet and loose clothing away from moving parts.

Some procedures described in this manual require work inside the indicator enclosure. These procedures are to be performed by qualified service personnel only.

When lowering the scale, ensure that everyone is clear of the scale and any moving parts.

Use two hands when gripping the lift handle to raise or lower the scale.

Be sure the gates are latched or tied inward before transporting the scale.

Ensure all three hitch lock pins are installed and the suspension stops are in the transport position before moving the scale.

1.2.1 Animal Safety



CAUTION: Animal safety is a very serious issue and must be observed when handling any type of animal.

The scale surface may become slippery during use; a buildup of manure on the scale may reduce traction. It is recommended that necessary precautions are taken to maintain an acceptable level of animal footing.

1.2.2 Calibration

Do not calibrate this scale with a weight cart having a gross weight in excess of 25% of the total capacity of the scale (3,750 lb or 1,700 kg max for the MAS-P 8 x 13, 5,000 lb or 2,268 kg max for MAS-P 8 x 18). This device is designed to be calibrated with single block weights spread evenly throughout the floor of the scale. Shift tests should not be done with more than 4,000 lb or 1,815 kg in a 4' x 4' area.



IMPORTANT: Failure to comply with this warning will result in damage to the scale and void the warranty.

1.2.3 Safety Decals



1



2



3



4



5



6



7



8

NOTE: Items 2-4 are on units equipped with the 920i Weighcenter only.

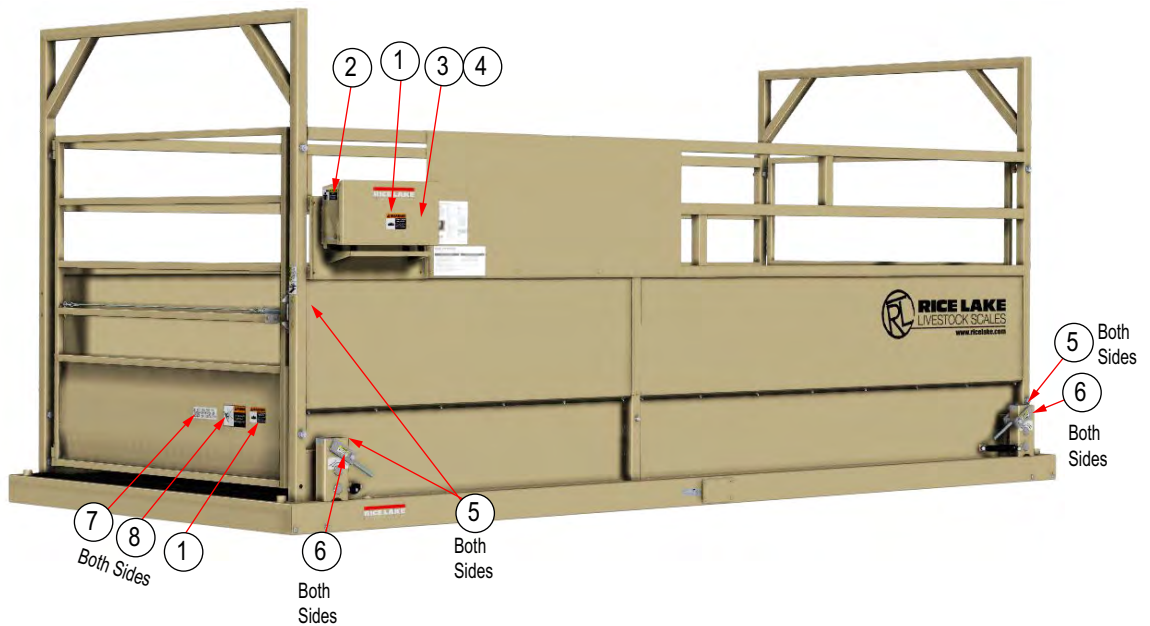

Figure 1-2. Safety Decal Locations

Item No.	Part No.	Description	Qty
1	151908	Read Manual	3
2	151904	Caution, Low Clearance (Weighcenter)	1
3	151906	Warning, Do Not Open (Weighcenter)	1
4	151907	Warning, Do Not Leave Tray Down (Weighcenter)	2
5	151909	Caution, Pinch Point	14
6	151910	Caution, Always Grip With Two Hands	4
7	128266	Do Not Use For Transportation of Goods	2
8	151902	Warning, Opens Quickly	2

Table 1-1. Safety Decals Parts List

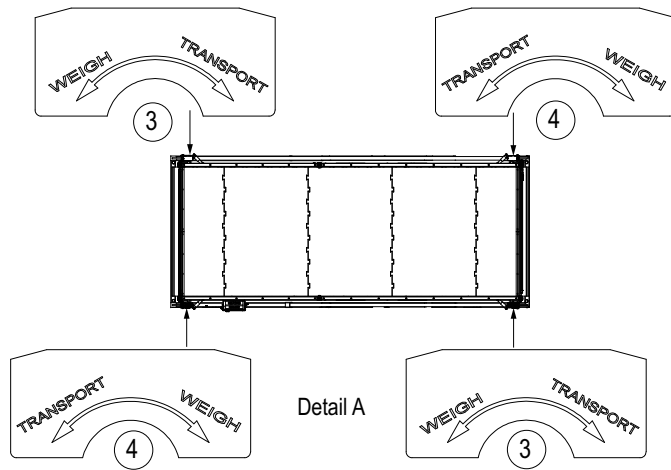
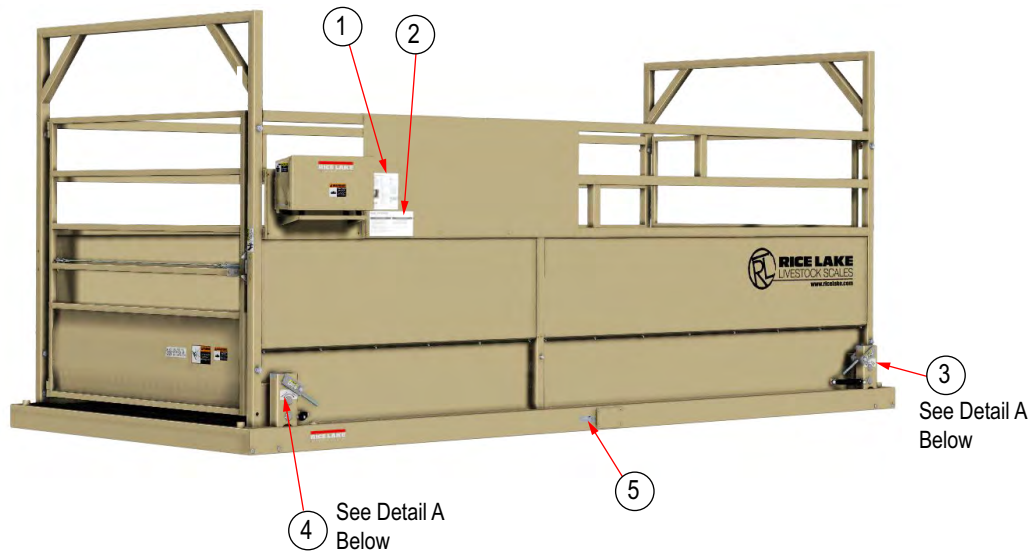

Figure 1-3. Non-Safety Decals

Item No.	Part No.	Description	Qty
1	164911	Label, 920i Weighcenter Operation	1
2	127091	Label, Basic Operation	1
3	132692	Label, Weigh/Transport	2
4	127094	Label, Weigh/Transport	2
5	16863	Serial Number Label	1

Table 1-2. Non-Safety Decals Parts List

1.3 Unloading

Follow instructions below to unload the scale.

1.3.1 Slinging the Scale

The MAS-P can be slung with four equal length straps connected from the lifting lugs to a single point in the center.

- Strap length 8 x 13 = 7' minimum
- Strap length 8 x 18 = 10' minimum

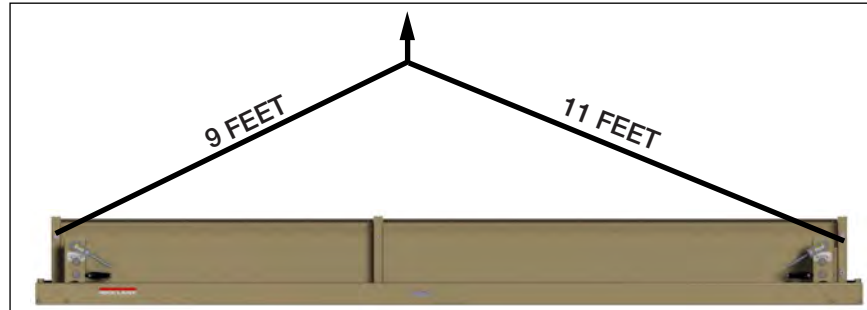

Figure 1-4. Sling Scale

1.3.2 Lift the Scale

If stacked, monitor the four corners directly below the lifting fixtures. Each corner has a shipping stub inserted, these stubs are not bolted in place, ensure they remain with the lower scale.

1. Discard the shipping stub once the upper scale of the stack is removed.

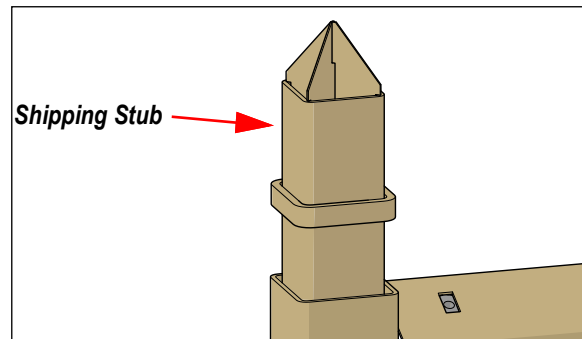

Figure 1-5. Shipping Stub

2. The scale can now be stored or placed on a relatively flat location to be assembled.

1.3.3 Remove Lifting Fixture

Remove the lifting fixture after the scale has been placed in position.

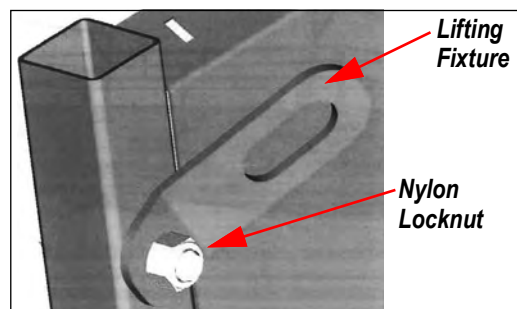

Figure 1-6. Lifting Fixture

1. Remove nylon locknut from the bolt installed for shipping.
2. Remove lifting fixture from bolt.
3. Reinstall nut, retain lifting fixture for future moves.

1.4 Lifting Assembled Scale

Lift the scale only in designated locations. The scale can be lifted by four straps and a crane or loader. Ensure the scale is in transport mode when loading and transporting the scale ([Section 2.3 on page 11](#)).

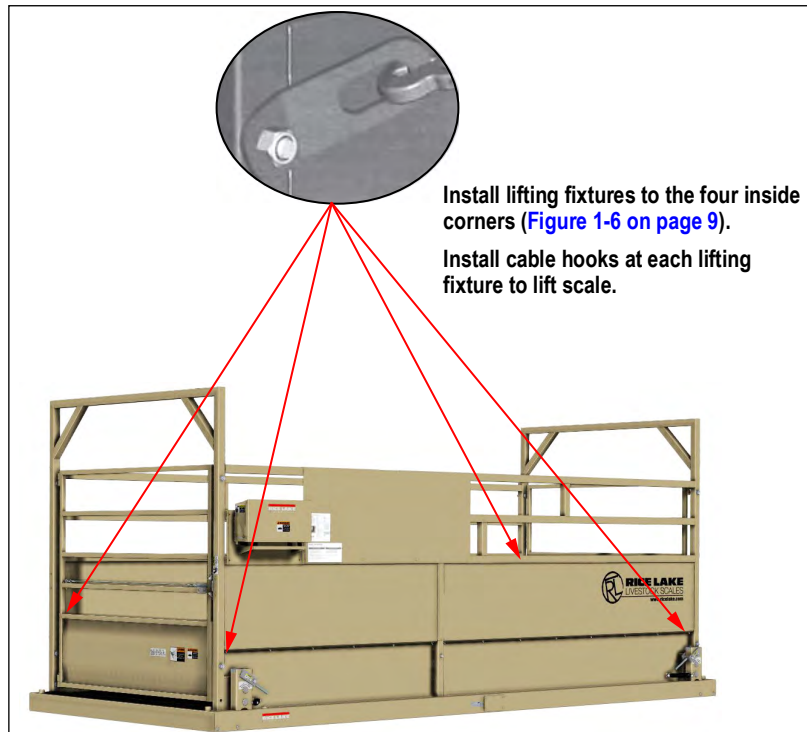

Figure 1-7. Lift Points

1.5 Indicator Package Removal

The indicator is shrink-wrapped for transportation. Be careful when removing to avoid damaging the indicator. Remove the indicator, then re-strap the walls if the scale is to be transported while packaged.

2.0 Installation

As with any weighing equipment, the accuracy of the scale is dependent on the installation. The following points must be adhered to when installing the MAS-P Animal Scale.

In all installations, the scale must be level to ensure proper operation. All MAS-P Animal Scales are equipped with a bubble level (located on top of the base frame). Ensure the bubble is fully inside the circle marked on the top of the level.

2.1 Permanent Installation

Rice Lake Weighing Systems recommends a concrete foundation (piles or piers) for permanent installations. The foundation must be able to support the gross weight of the scale (scale dead weight plus scale capacity), and the piles or piers must be situated directly under the load cell stands (shimming location). The foundation must not be subject to distortion or motion due to frost action. A qualified local professional should be consulted to recommend the proper size of foundation for the location. Foundation dimensional requirements are available from the dealer or Rice Lake Weighing Systems. Requirements may vary from one Weights and Measures jurisdiction to another, please contact the local office.

2.2 Portable Installation

The MAS-P is ideal for use in many locations. Load and unload the scale as described in the [Section 1.4 on page 10](#). Place the scale in a level location, then shim (with wood or metal shims) under the load cell stands to ensure scale is level. Please contact the local Weights and Measures office regarding the moving of the scale to ensure the validity of the certification.

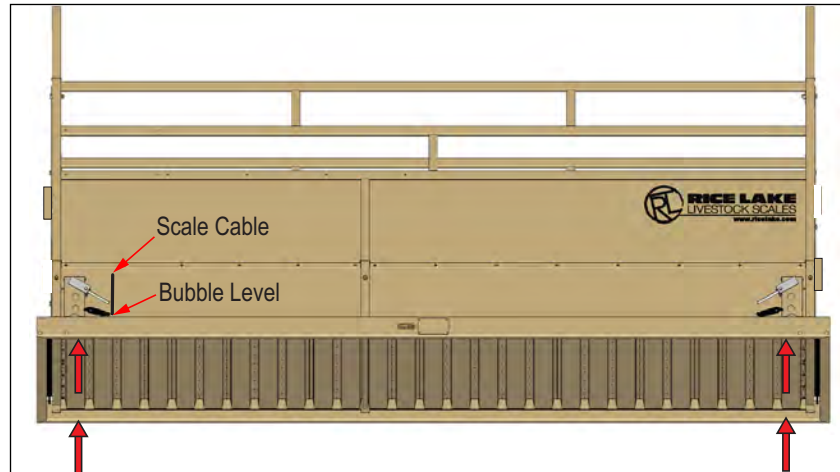

Figure 2-1. Shim/Load Cell Stand Locations

2.3 Switching Modes

The MAS-P has two modes, Weigh and Transport.

2.3.1 Convert to Weigh Mode

1. Place the scale in as level a location as possible.
2. Ensure there are no obstructions under the deck that would affect weighing accuracy.
3. Check the bubble level. Use shims or timbers to ensure the scale is as close to level as possible. The scale weighs properly on any firm surface up to 6% grade (3° slope).
4. Inspect all corners of the scale. Although the scale weighs properly up to 3° off level, individual corners of the scale should not be allowed to teeter. If any of the corners are not contacting the ground, place shims directly under the base frame under the load cell stands, to prevent teetering.
5. Plug the indicator into the scale cable. The scale cable runs from the junction box (inside the base frame) to the indicator.
6. Connect power to the indicator and switch **ON**.
7. Using both hands, raise the platform to enable the scale ([Figure 2-2 on page 12](#)). The scale is now ready to weigh.



WARNING: The lift mechanism is an over center cam style lift and lock. If not disturbed, the scale will remain locked in the up position. Always grip lift handle with two hands when raising and lowering the scale.



NOTE: Cam levers point toward each other in weigh mode and away from each other in transport. See decals for direction of levers in each mode.

2.3.2 Convert to Transport Mode

When the scale is not in use, the scale should be locked down in transport mode to prevent any accidental overload of the weigh system.

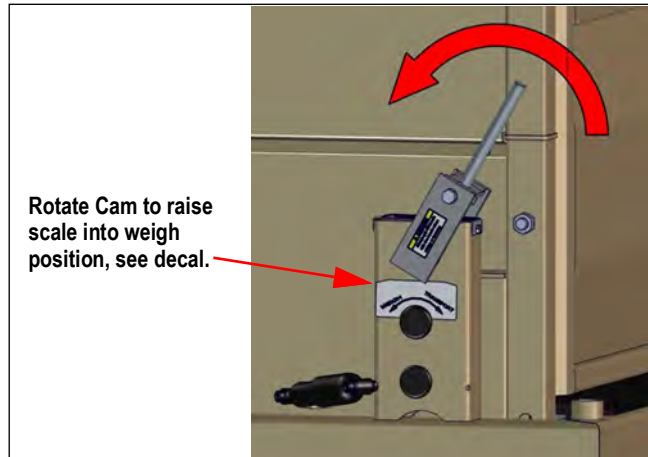

Figure 2-2. Scale Lift

1. Using both hands, disengage and lock the scale in transport mode by rotating all four cam levers counterclockwise into the fully locked position.



WARNING: The lift mechanism is an over center cam style lift and lock. If not disturbed, the scale remains locked in the up position. Always grip lift handle with two hands when raising and lowering the scale.



NOTE: Cam levers point toward each other in weigh mode and away from each other in transport. See decals for direction of levers in each mode.

2. Turn off indicator.

A stand alone indicator should be stored indoors when the scale is not in use. The weighcenter should be closed and latched to prevent damage.

2.4 Cage Wall Assembly

2.4.1 Apply the Silicone Bead

Add a silicone bead before installing the walls.

1. Use mineral spirits to clean the upper flange of the floor and the lower wall flange.
2. Apply a 1/8" bead of silicone along the upper edge of the floor panel along the entire length.

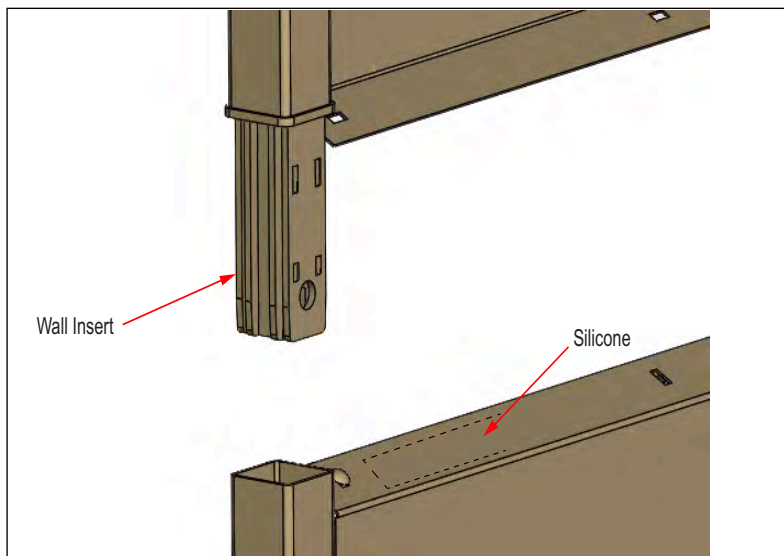

Figure 2-3. Silicone Bead

2.4.2 Install Walls



WARNING: Wall installation should be done with two people or an overhead crane.

1. Lift the first wall using one sling in the center. The wall with holes for the indicator is mounted on the left side.
2. Stand the wall vertically and place the inserts from the wall into the tubes of the cage floor. The more vertical the wall, the easier assembly will be.
3. Repeat for opposite wall.
4. Install the top cross-members.
5. Place the 3/4" x 3 1/2" bolts through cage wall and insert on indicator side of cage, head of bolt to the inside.



NOTE: A come-along from the top of the cross member to bottom of the cage corner post may be required. A ratchet strap is provided in hardware kit.

When both walls are in place, ensure they are perfectly square. Straps may need to be used to pull for squareness.

2.4.3 Install the Gate



NOTE: Install gate with hinge bolts on opposite side of scale.

Hinge bolts must be assembled with lock washer on the inside of gate and jam nut on the outside.

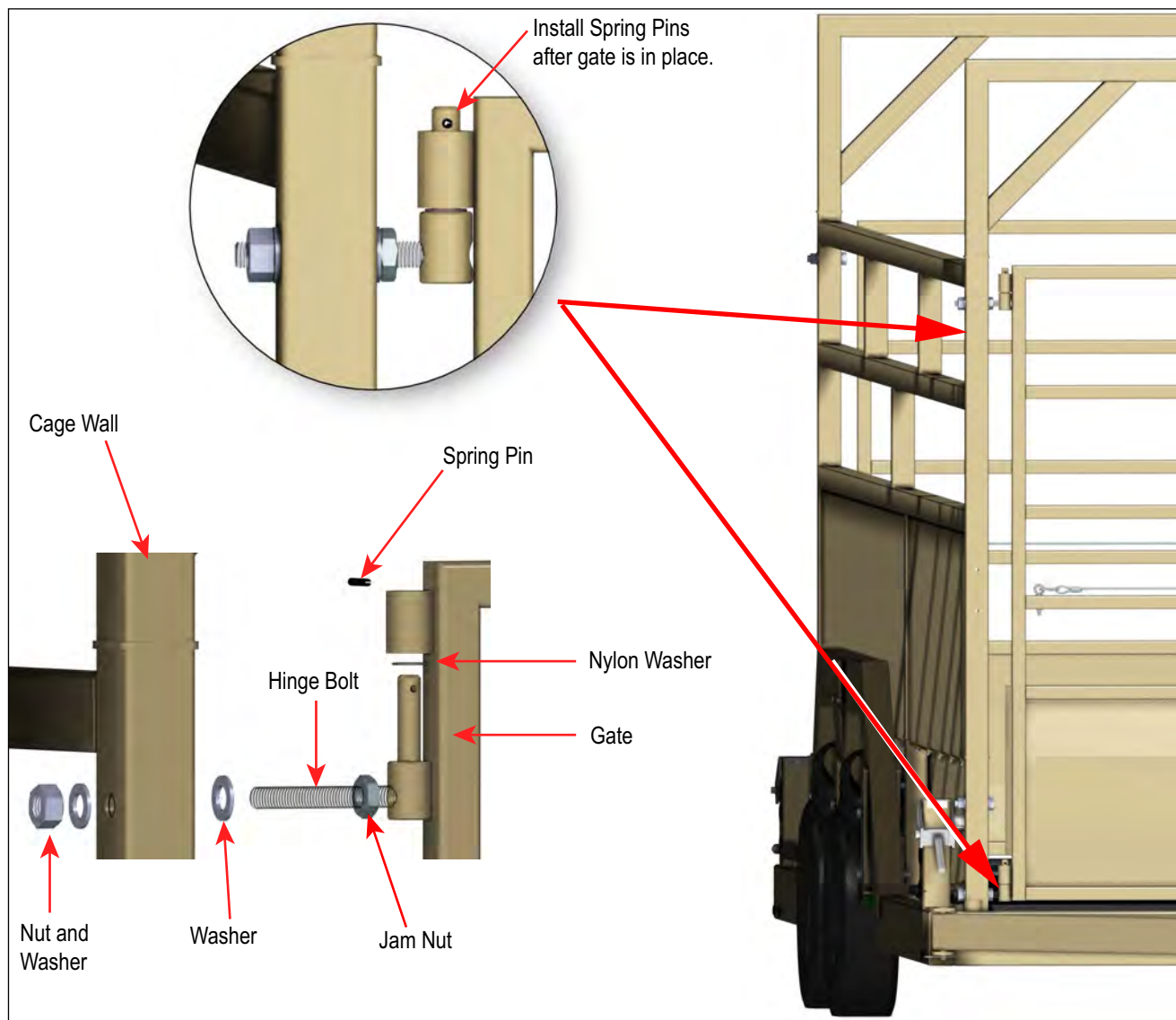

Figure 2-4. Assemble Gate to Scale

1. Install jam nut and lock washer onto hinge bolts. Screw the nut on about 2".

2. Insert one hinge bolt into the lower and upper holes of cage wall with hook portion pointing upward.
3. Install nut and washer onto hinge bolts, securing them to cage wall.
4. Place nylon washer onto hook portion of the upper and lower hinge bolts then install gate onto the hooks.
5. Insert the roll pin through hinge bolts.
6. Repeat steps 2-4 for second gate.
7. Adjust hinge side gap between gate and cage wall to about 3" and snug hinge bolts.

2.5 Gate and Latch Adjustment Procedure



NOTE: Assemble gates according to the following criteria:

Hinge Bolts - Assemble with lock washer on inside of gate and jam nut on the outside.

Hinge Side Gap - Approximately 3" between the gate and the corner post.

Gate Latch Pin - Install rubber tubing on the latch pin (Mobile units only).

Adjust gates as follows:

1. Adjust the hinge bolts to align the top of the gate on the latch side with the top of the cage wall.
2. Adjust the hinge bolts so the latch side gap is about 1 1/2".
3. Install and adjust the latch so the gate latch pin does not rub on the top or bottom of the latch. Adjust the hinge bolts only if necessary.
4. Ratchet straps can be used diagonally to help square up gates to walls.

2.6 T-Belt

Ensure the T-Belt hold down loops are installed and hooked into the corner posts of the cage.

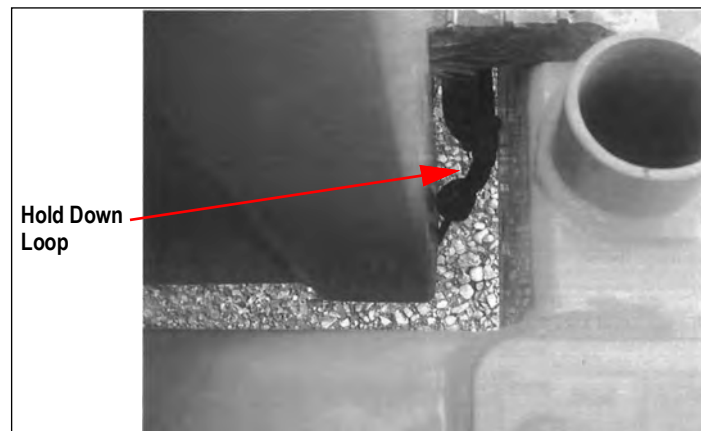

Figure 2-5. T-Belt

2.7 Optional 920i Weighcenter Mounting

The MAS-P is NTEP approved only when purchased with 920i Weighcenter. When using other indicators, it must be re-calibrated each time it's moved.

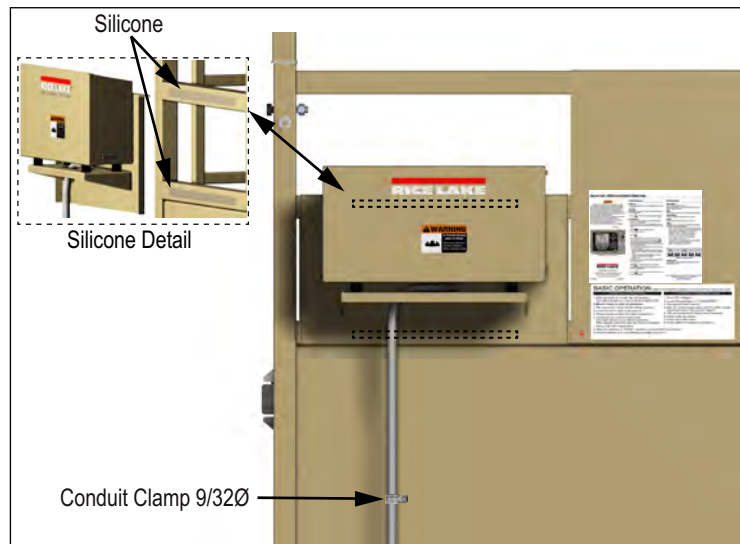

Figure 2-6. Mount Weighcenter

1. Before installing the bracket, a bead of silicone must be added.
2. Clean the wall tubes where the bracket will mount and the space between the holes on the mount bracket with mineral spirits.
3. Place the mounting bracket on the cage wall by pressing the adhesive tightly to the cage.
4. Secure with four bolts.
5. Mount the weighcenter onto the mounting bracket and route the cable.
6. Install the clamps to secure the conduit.
 - Mount the upper conduit clamp using the lower left mounting bracket bolt.
 - Secure the lower end of the conduit by drilling a hole through the cage sheeting and installing the clamp with the bolt provided.

2.8 Optional AC/DC Power Supply Adapter Box Kit

To install the AC/DC Power Supply Adapter Box on a portable animal scale, see the following sections.



Figure 2-7. AC/DC Power Supply Adapter Box Kit

2.8.1 Mounting to Scale

The mounting bracket can be positioned anywhere along the frame within the limits of the conduit.

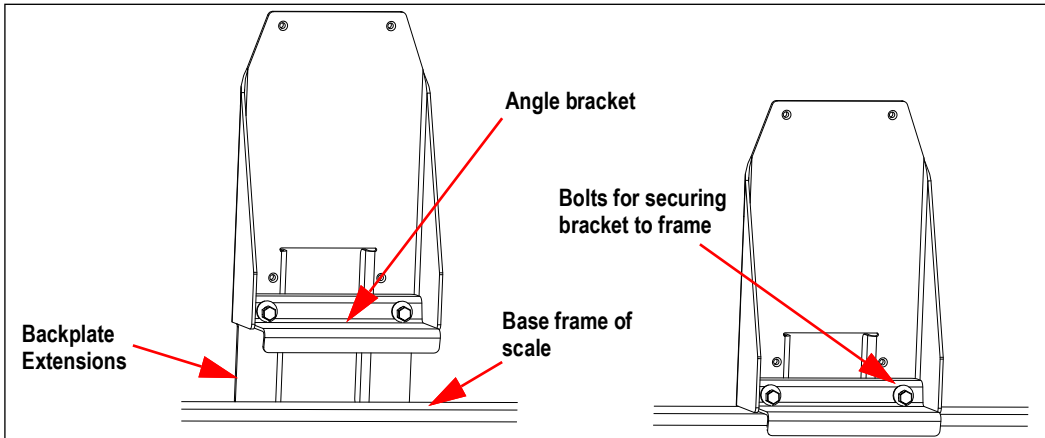

Figure 2-8. Mounting Power Box Assembly to Frame

1. Place the mounting bracket assembly on the outer beam of the bottom frame on the scale in desired location. The angle bracket should extend past the front of the beam, and backplate extensions should be flush with the back of the beam.
2. Tighten bolts to secure to frame. Ensure they are tight enough to resist movement when scale is in use.



NOTE: When ordering a complete package, the enclosure box is assembled to the mounting bracket. Skip to [Step 4](#).

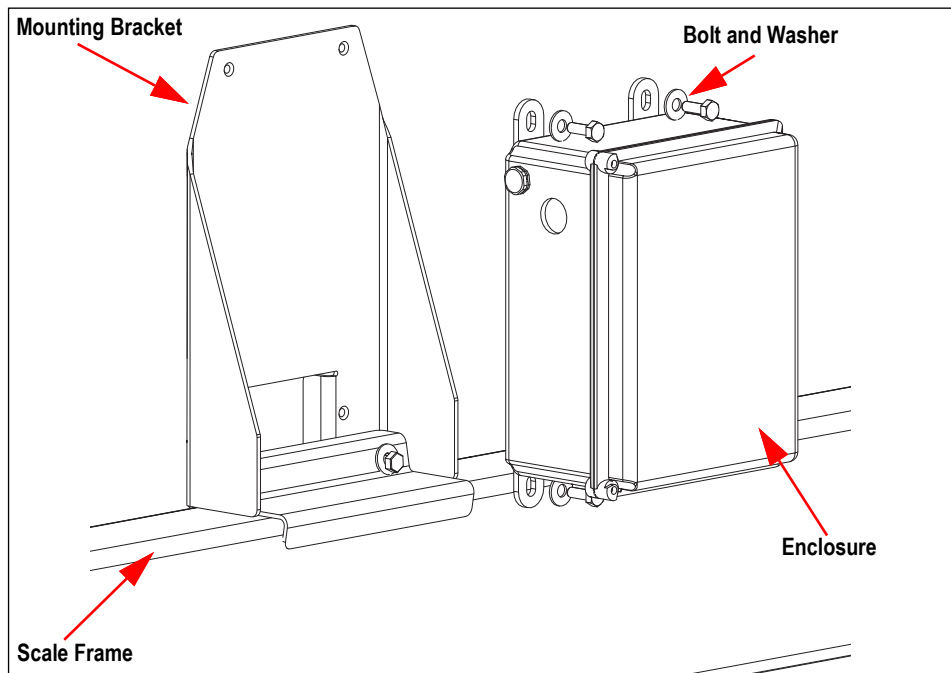

Figure 2-9. Mount Enclosure Box

3. Mount the enclosure box to the mounting bracket using the bolts and washer supplied.

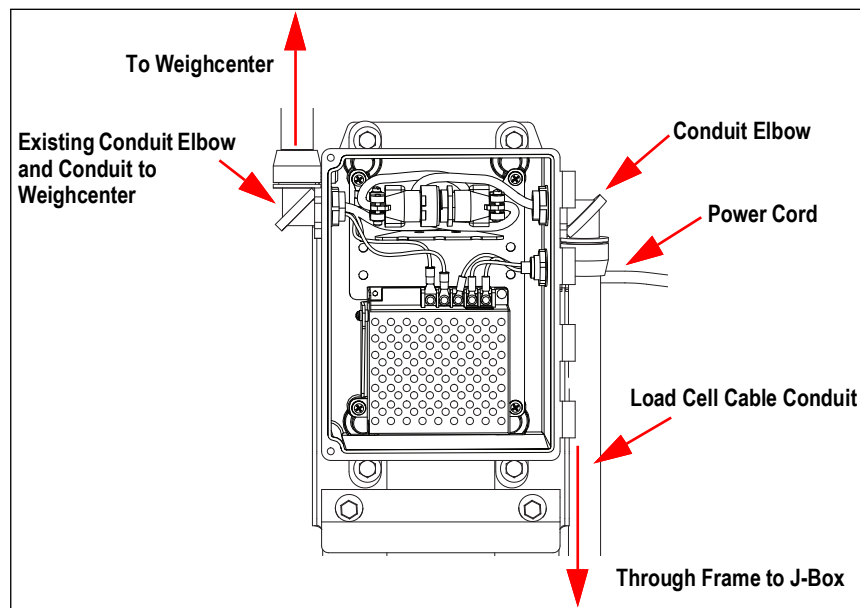

Figure 2-10. Wiring Diagram

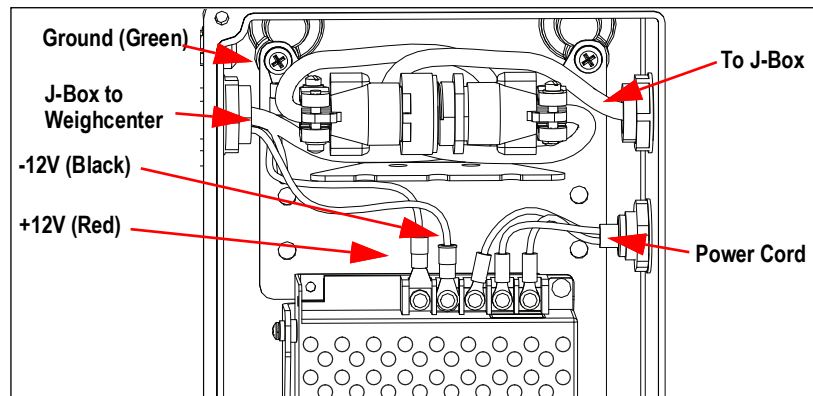

Figure 2-11. Power Supply Connections

4. Disconnect the homerun cable from the weighcenter and pull it out of the conduit and conduit elbow. See the weighcenter manual (PN 159192).
5. Insert the conduit elbow into the designated hole in the enclosure. Secure with nut.
6. Pass the weighcenter cable from the inside of the enclosure through the conduit elbow and conduit to the weighcenter.
7. Reconnect the cable to the weighcenter.



NOTE: The cable to the weighcenter is part of existing assembly and runs through existing conduit retrofitted to power supply box.

8. Disconnect the cable from the junction box.
9. Connect the conduit elbow to the enclosure at designated hole and secure with nut.
10. Connect the other conduit elbow to the frame near the junction box.
11. Pass the junction box cable through the conduit elbow, supplied conduit and conduit elbow on the frame.
12. Reconnect the junction box cable to the junction box.
13. Connect the junction box cable connector and the weighcenter cable connector inside enclosure.
14. Secure connectors and excess cable with zip-ties inside the enclosure.

2.9 Wiring the Scale

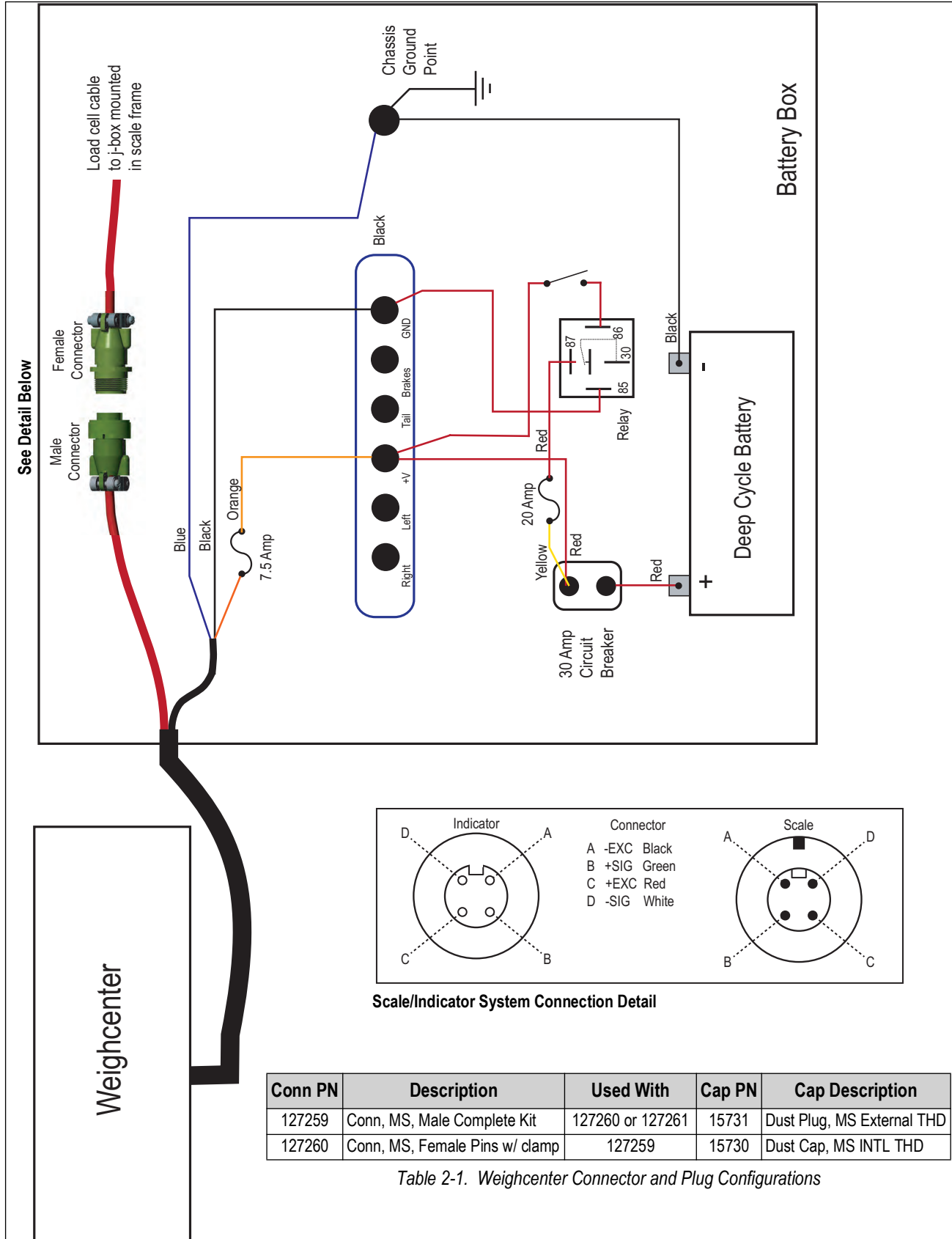

Figure 2-12. Scale Wiring Diagram

2.10 Battery Box Connections

To use with the optional battery box (PN 153765):

1. Connect the scale cable and secure with a cable tie.
2. Connect the power wires (Figure 2-12 on page 18).
3. Replace the battery cover.

2.11 Load Cell Wiring Diagrams



NOTE: Load cell wiring shown is effective for all models built after 09/17/2013. Models built prior to this date should rewire the scale to the updated configuration. For information on rewire, download Technical Bulletin (PN 159193) from www.ricelake.com

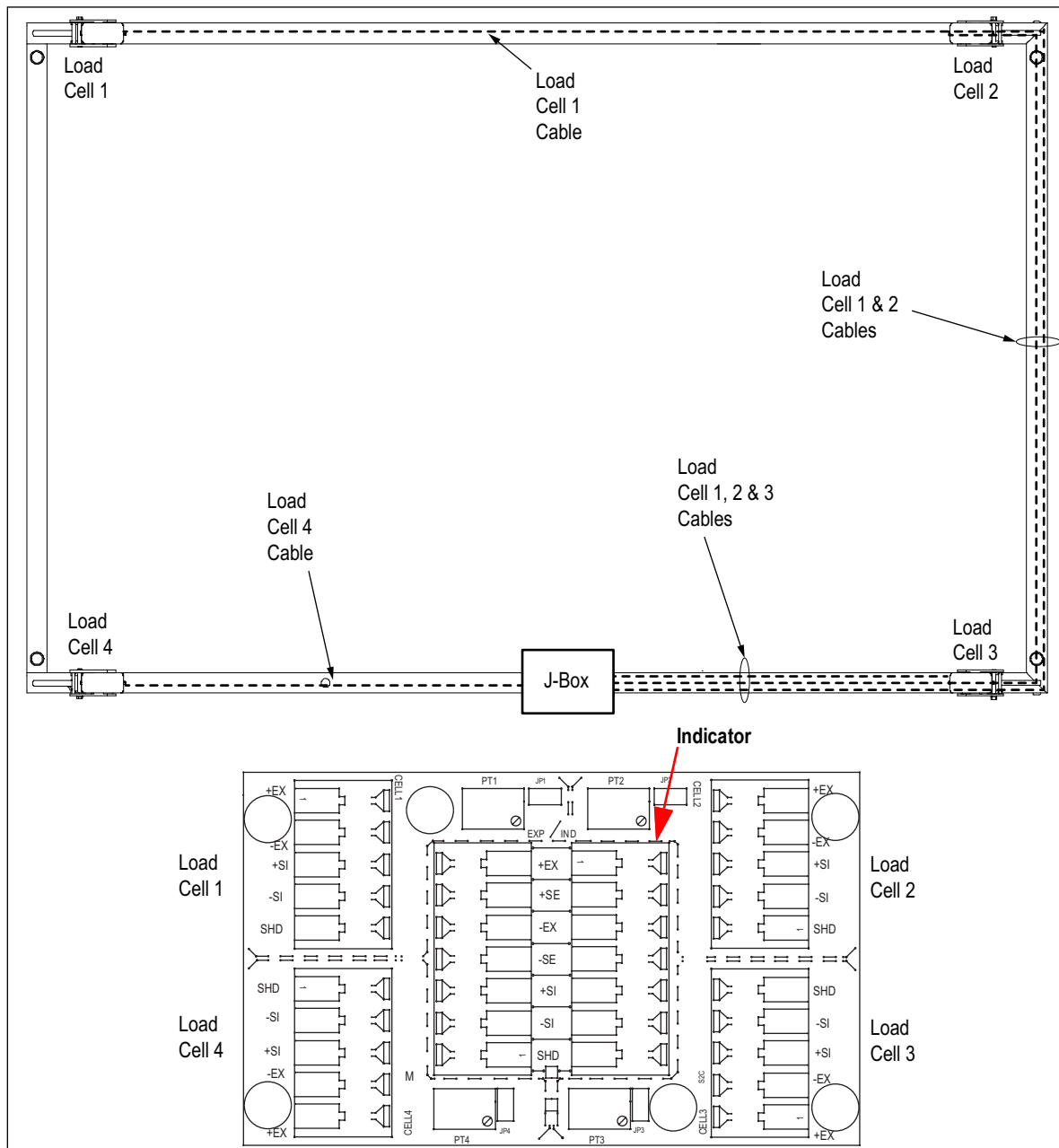

Figure 2-13. Load Cell Wiring Diagram

3.0 Repair Parts

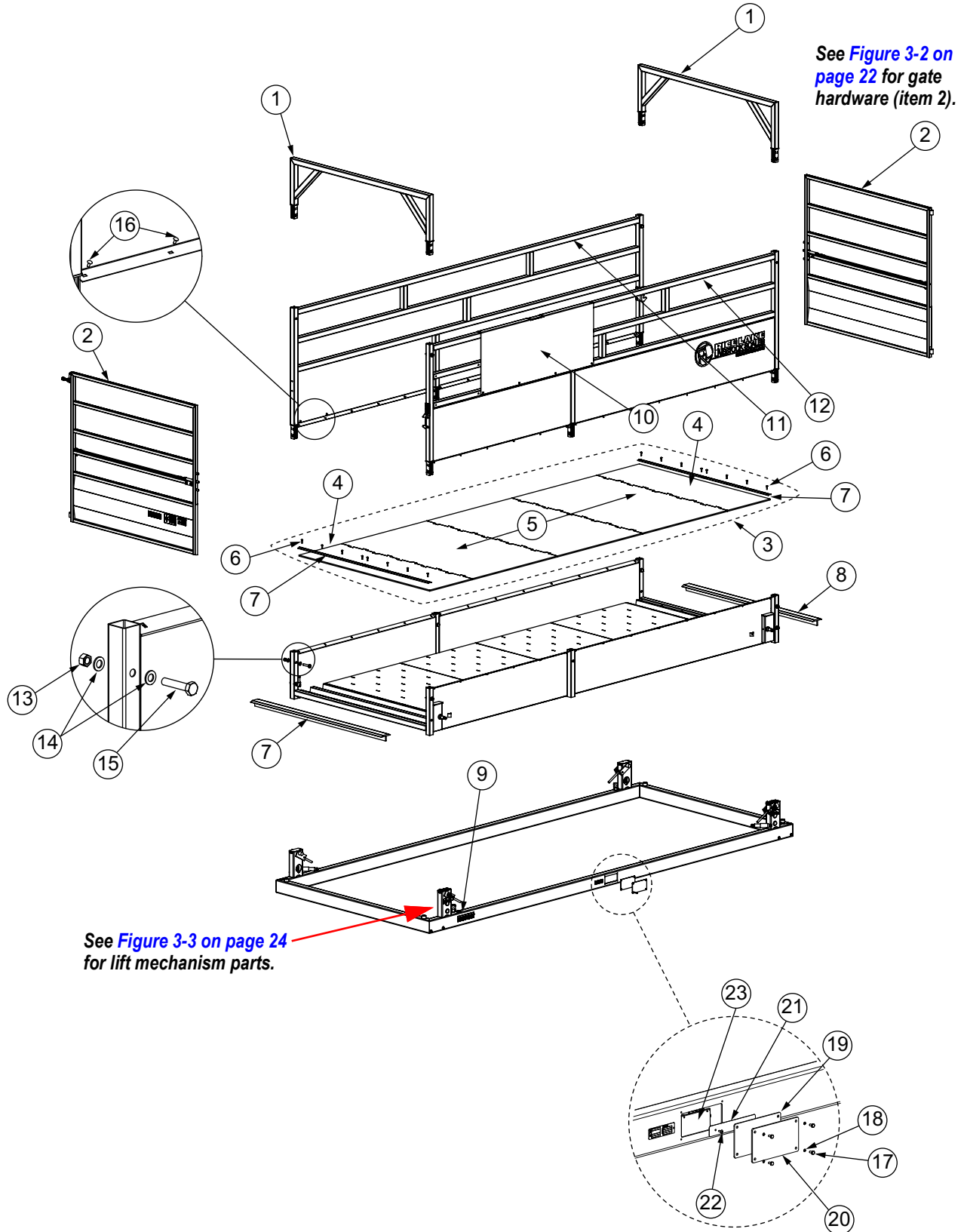

Figure 3-1. MAS-P Parts Illustration

Item No.	Part No.	Description
1	130931	Cage Cross-member
2	131782	Gate, MAS, see Figure 3-2 on page 22
3	131992	Mat Installation Kit - 13' (Includes items 4-7)
	131993	Mat Installation Kit - 18' (Includes items 4-7)
	128280	Adhesive, Insta-Cure + (13' Qty 1 / 18' Qty 2)
	126775	Sealant, Silicone II Black (13' Qty 2 / 18' Qty 3)
4	127234	Matting, MAS End Section - 13' (Qty 2)
	127236	Matting, MAS End Section - 18' (Qty 2)
5	127235	Matting, MAS Center - 13' (Qty 1)
	127235	Matting, MAS Center - 18' (Qty 3)
6	127053	Bolt, Carriage 5/16-18
	21939	Washer, Plain 5/16 Type A
	35170	Nut, Lock 5/16-18NC Hex
7	131855	Mounting Strip, Rubber
8	126787	Belting, Scale T Profile (83" width)
	127271	Hold Down Loops
9	127081	Bubble Level Circular
10	130022	Operator Shield
	128169	Screw, Self Drilling 12-24 x 7/8
11	131708	Cage Wall 13'
	131946	Cage Wall 18' Right
12	131708	Cage Wall 13'
	131947	Cage Wall 18' Left
13	14697	Nut, Lock 3/4-10 Hex, Nylon Insert Zinc
14	15179	Washer, Plain 3/4 Type A
15	15097	Cap Screw, 3/4-10NC x 3-1/2 (18' center only)
	15099	Cap Screw, 3/4-10NC x 3-3/4 HEX head Grade 5 Steel
16	72083	Bolt Carriage 5/16 x 1/2 Round Head Grade A Zinc
	14646	Nut 5/16 Flanged Serrated
	21939	Washer, Plain 5/16 Type A
17	127007	Screw, Cap 1/4-20 x 1/2
18	31546	Washer, Lock 1/4 Internal Tooth
19	126819	Foam Gasket Junction Box
20	127740	Cover Plate Scale Frame/Junction Box
21	131885	Mount Plate for Junction Box
22	121129	Screw 10-32 x 0.5
	14633	Nut, 10-32
23	88956	Junction Box
NS	127561	Scale Cable Female MS Conn 132"
NS	131374	Paint, Touch-up

Table 3-1. MAS-P Parts List

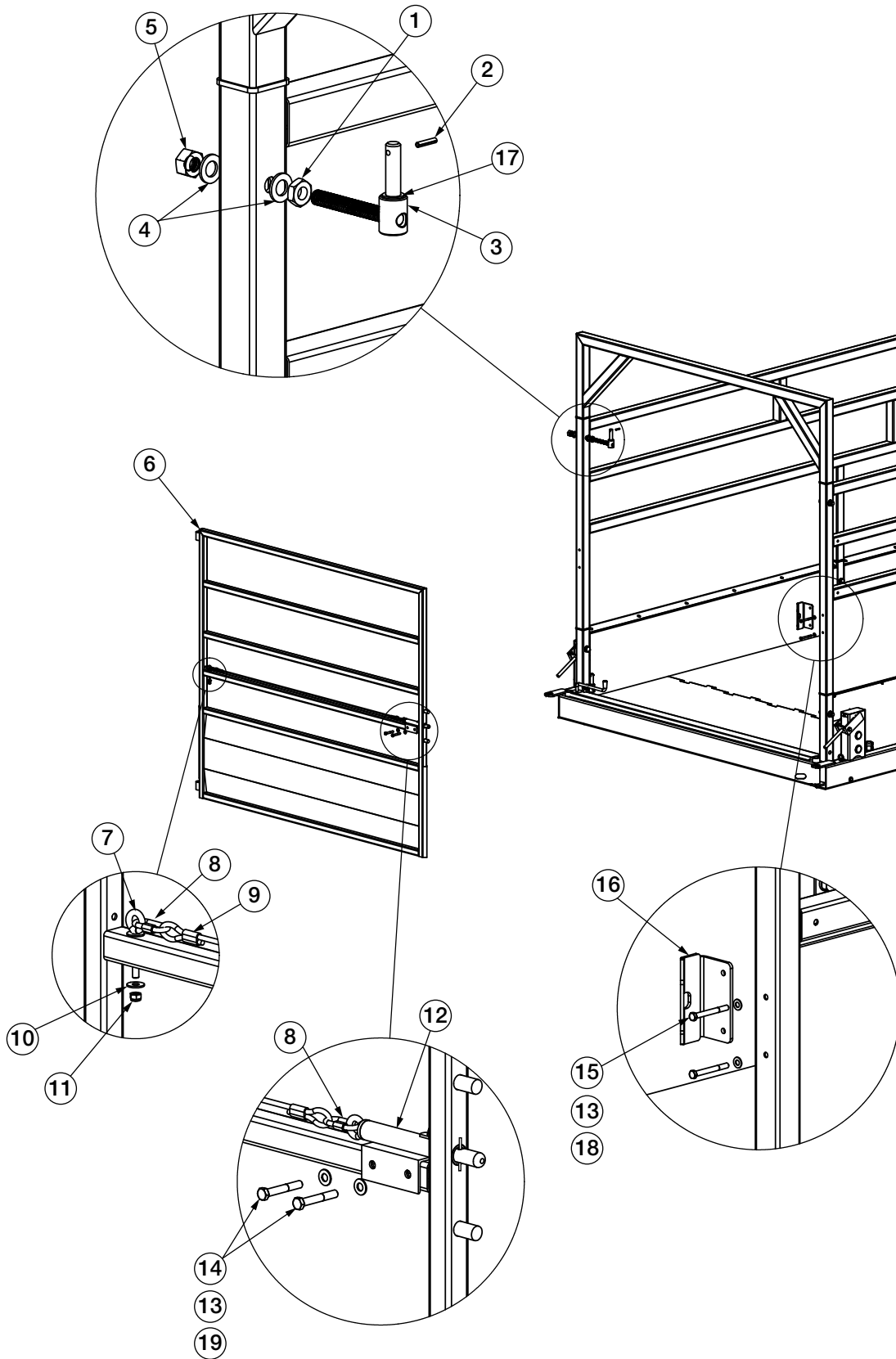

Figure 3-2. Gate Component Details

Item No.	Part No.	Description
1	132217	Jam Nut, 3/4-10NC
2	110950	Pin, Spring 1/4 x 1 1/4"
3	165944	Hinge Bolt
4	14697	Washer, 3/4"
5	111074	Nut, 3/4-10NC
6	131782	Gate, MAS
7	131701	Eye Bolt, 5/16-18 x 2 1/2"
8	131887	Quick Link 1/4"
9	131886	Cable, 1/4" OD x 6'
10	21939	Washer, 5/16"
11	14646	Nut, Lock 5/16-18NC
12	131784	Gate Latch Assembly
	131702	Spring
	160302	Hairpin
13	21938	Washer, 3/8 Lock (4 per strike plate)
14	151559	Cap Screw, 3/8-16NC
15	151560	Cap Screw, 3/8-16 x 3/4
16	155916	Strike Plate
17	151807	Washer, Plain 3/4" Nylon
18	22072	Nut, 3/8-16 Grade 5
19	132684	Nut, (Used with Latches)

Table 3-2. MAS-P Gate Parts List

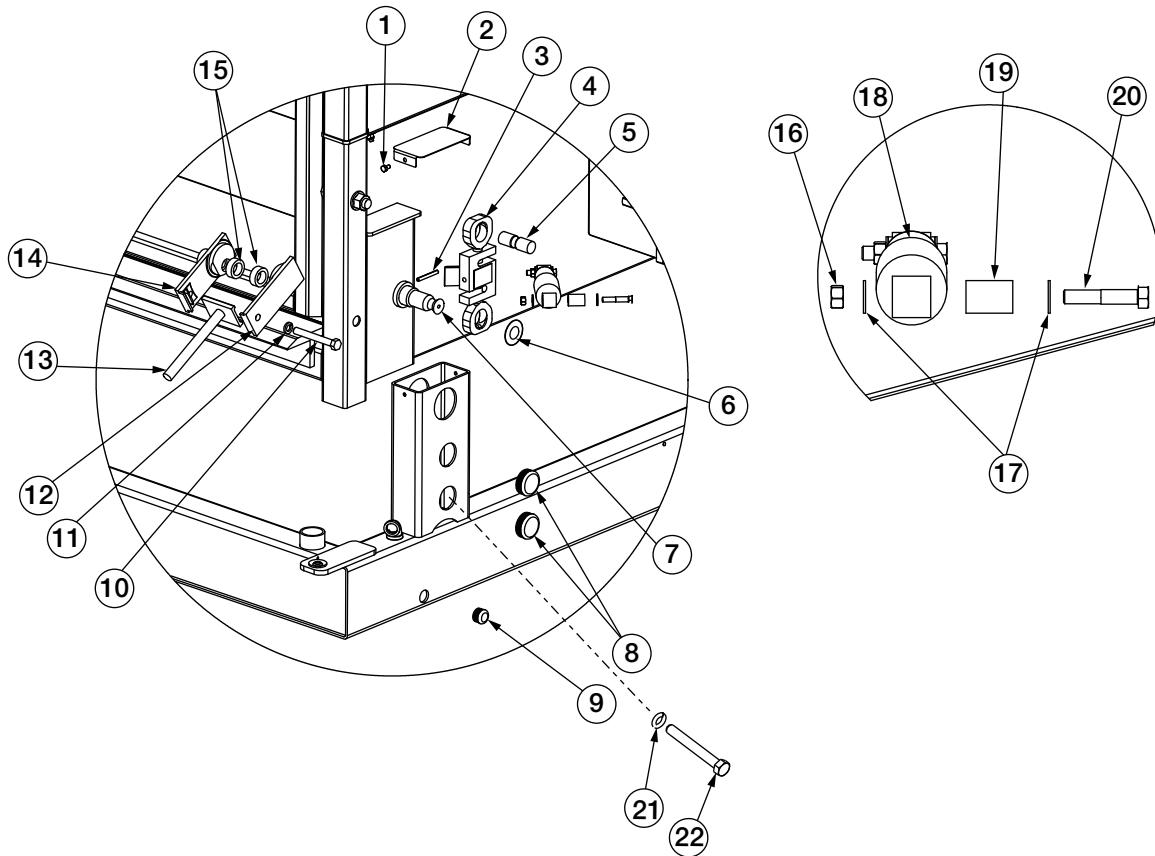

Figure 3-3. MAS-P Lift Mechanism Detail Parts Illustration.

Item No.	Part No.	Description
1	127007	Cap Screw, 1/4-20 x 1/2"
2	127200	Load Cell Cam Stand Cover SS
3	126926	Pin Spring Slotted 1/4 x 2-1/4"
4	127673	Load Cell S-Type 10K
5	128184	Upper Notched Load Cell Pin
6	174640	Lower Load Cell Retainer
7	127177	Lower Notched Load Cell Pin
8	126789	Plug Plastic Round 2"
9	126788	Plug Plastic Round 1-1/8"
10	14765	Bolt 1/2-13NC x 4
11	15167	Lock Washer 1/2"
12	131785	Cam Lever Without Lock-down - Right Rear
	127676	Cam Lever with Lock-down - Left Rear
13	127732	Cam Handle Mask
14	131787	Cam Lever with Lock-down - Front Left
	127675	Cam Lever Without Lock-down - Right Left
15	127165	Spacer Upper Notched Pin
16	14656	Nut 3/8" SS
17	15161	Flat washer 3/8" SS SAE
18	128626	Scale Damper Assembly w/Bushings
19	126815	Bushing, Rubber 7/8 OD x 3/8 ID x 1.25 Long
20	22093	Cap Screw, 3/8-16NC x 2 Hex
NS	127561	Scale Cable Female MS Conn 132"

Table 3-3. MAS-P Lift Mechanism Parts List

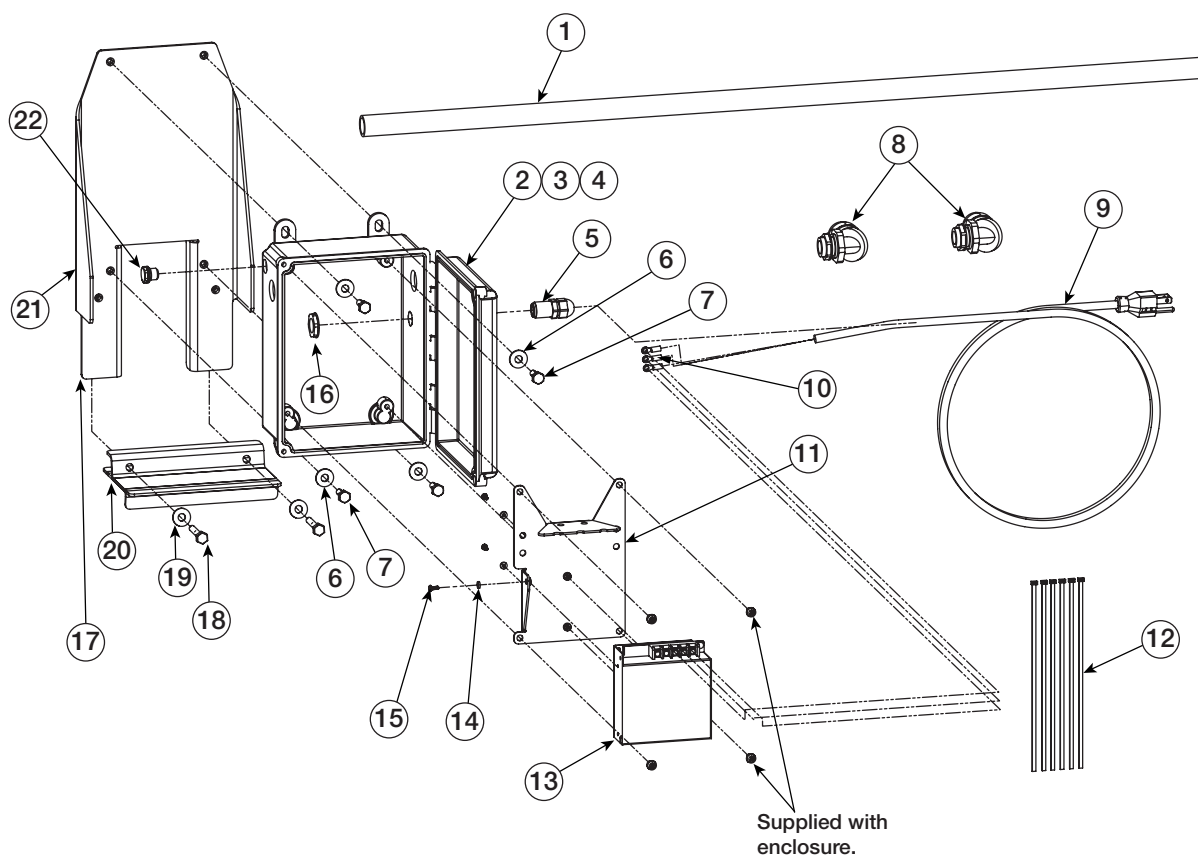

Figure 3-4. AC/DC Power Box Parts Illustration

Item No.	Part No.	Description
1	128123	Conduit, Non Metallic
2	156759	AC/DC Adapter Box
3	151901	Decal, Caution Not a Step
4	151906	Decal, Warning Do Not Open
5	15656	Locknut, 3/8 NPT
6	81427	Washer, Flat 1/4 Steel Screw, Cap 1/4-20 x 3/4"
7	127008	Screw, Cap 1/4-20 x 3/4"
8	127135	Conn, Non Metallic Liquid
9	105380	Power Cord, Pigtail
10	15694	Conn, Eye Crimp No 8
11	156795	AC/DC Power Supply, Mount
12	16141	Cable Tie, 8" Nylon
13	156761	Power Supply, Switching
14	127028	Washer, Flat No 4 18-8 SST
15	41757	Screw, Cap M3-0.5 x 8
16	15655	Cable, Grip 3/8NPT
17	156760	AC/DC Mounting Assembly (Includes Items 18-21)
18	106462	Screw, Cap, 1/4-20NC x 1 1/2"
19	81427	Washer, Flat, 1/4" Steel
20	156764	Mounting Bracket, Angle
21	156829	Mounting Bracket
22	128022	Vent, Integrated Screw

Table 3-4. AC/DC Power Box Parts List

4.0 Maintenance

4.1 Maintenance Schedule

Weekly

1. Check entire scale for buildup of debris. Remove any debris found on, under or around the scale.
2. Check for dirt and debris in the load cell stands and clean accordingly.
3. Check all external cables and conduit for damage.

Yearly (in addition to weekly and monthly maintenance)

Disassemble each load cell location and grease all pins and eye bolts.

4.2 Scale Maintenance Procedures

Cleaning Load Cell Stands

It is very important to keep any excess debris from building up in the load cell stand. Lift scale and block it up, clean any dirt out of the load cell stands through the drain holes located at the bottom of the stand.

Disassembly and Greasing

This is very important to ensure the long life of the unit. Use the parts list drawings for item numbers.



NOTE: Use quality high-pressure grease.

Avoid bending or twisting the load cell wires.

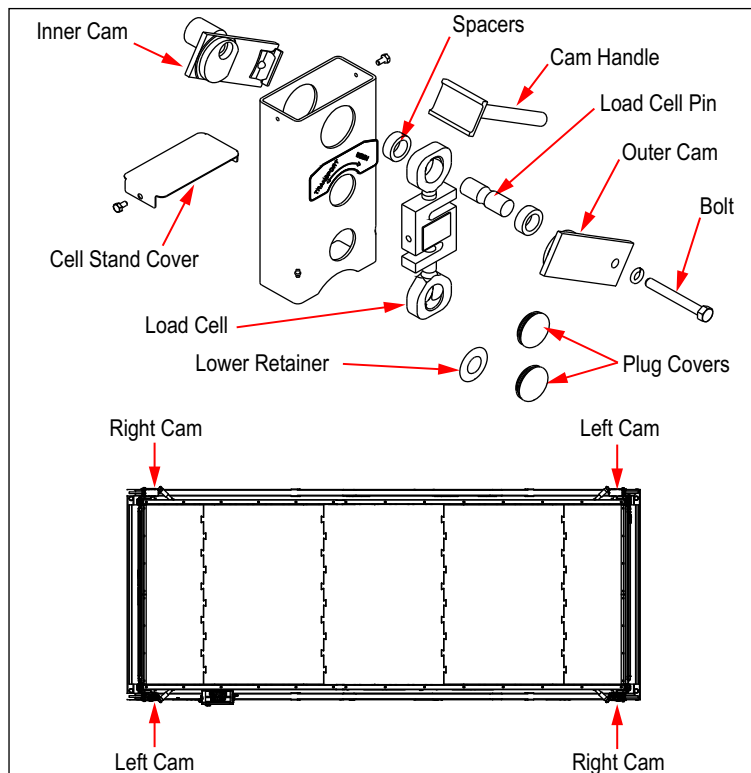

Figure 4-1. Disassembly and Greasing

1. Remove cell stand cover.
2. Remove plug covers.
3. Remove the bolt which holds together the outer cam, load cell pin and inner cam.
4. While holding the cam handle, remove the outer cam.

5. Remove load cell pin and spacers. The load cell assembly is free on top and rests against the inside of the cell stand.
6. Remove inner cam.
7. Remove lower retainer.
8. Grease all bearing surfaces except where the eye bolt contacts the pin (upper and lower pins, cams, upper and lower eye bolts).
9. Reassemble in reverse order as described above.

4.3 Troubleshooting

Symptom	Probable Cause	Action
The scale indicator will not power up.	Blown in-line fuse .	Replace in-line fuse, PN 126870. The fuse holder is located near the battery or the indicator.
	Voltage is less than 11 volts.	Repair faulty electrical system. The RLWS panel requires at least 11 volts to operate properly.
Indicator turns off or resets in the middle of a transaction.	Low voltage to control panel.	Check other electrical equipment that may be operating. Check for corrosion or damaged wiring. Measure voltage.
The weight reading on the indicator is unstable.	The circuit board in the control panel may be wet or the junction box for the load cells may have moisture.	Dry any areas that are contaminated with moisture. Check for leaks and reseal.
	A load cell cable may be pinched or damaged.	Contact Rice Lake Weighing Systems or a qualified dealer for support. Cutting the load cell cable will void the warranty. Special repair techniques are required.
The scale has a positive error when loading or a negative error when unloading.	Mechanical binding problem on scale.	Check for debris around or under the scale. Check each load cell location for foreign material. Check all items that run from on the scale to off the scale. Check all gates or gathering panels for contact.
The scale has a negative error when loading or a positive error when unloading.	Moisture is present somewhere in the electrical system.	Dry any areas that are contaminated with moisture. Check for leaks and reseal.
Printer is not functioning – nothing is being printed at all.	Is the release light on the printer flashing? This could indicate a low voltage to the printer.	The system requires at least 11 volts to operate properly. The truck may need to be running to supply enough power, or the truck may have a faulty electrical system.
	The print head may be jammed with paper.	Remove the print head cover and ribbon. Check for bits of paper stuck in the paper feed mechanism.
	The print head may be packed with dirt from operating in dusty conditions	Remove the print head cover and ribbon. Blow out with air. If the printer is very dirty it may require service by a qualified technician.
The printer is printing unrecognizable characters.	The power supply is excessively noisy.	Contact Rice Lake Weighing Systems, an in-line power filter may be necessary.
	Incorrect dip switch settings.	Settings are 1,7,8 ON rest OFF.
The printing on the ticket is faint or hard to read.	The printer's ink ribbon may need to be replaced.	Replace ribbon, PN 29583.
	The printer head may be damaged.	Requires service by a qualified technician.
Scale will not ZERO.	Weight on scale larger than the allowable ZERO window.	Clean the scale deck of debris, then ZERO the scale.

Table 4-1. Troubleshooting



IMPORTANT: If a problem with the scale is suspected, contact Rice Lake Weighing Systems or a qualified local scale dealer.

4.4 Specifications

	MAS-P 8-13	MAS-P 8-18
Length Overall	13'- 6"	19'- 3"
Length Deck	12'- 9"	18'- 6"
Width Overall	8'- 4.13"	8'- 4.13"
Width Deck	6'- 11.5"	6'-11.5"
Deck Height	6"	6"
Height	100.2"	100.2"
Deck Covering	5/8 in Recycled Rubber Flooring System	
Weight	3230 lb	3940 lb
Capacity	15000 lb	20000 lb
Section Cap	10000 lb	20000 lb
Approval Class	IIIL (IIHHD)	IIIL (IIHHD)
Approvals	 99-091	Measurement Canada Approved AM4847
Grad Size	5 lb (2 kg)	5 lb (2 kg)
**Paint	Powder Coated Galvanized Steel	
**Structural Steel is not galvanized.		

Notes:

Size / Model # _____

Serial # _____

Date Purchased _____

Unit ID # _____



© Rice Lake Weighing Systems Content subject to change without notice.

230 W. Coleman St. • Rice Lake, WI 54868 • USA USA: 800-472-6703 • International: +1-715-234-9171