

TP Series Balance

Tuning Fork Precision Electronic Balance

Technical Manual

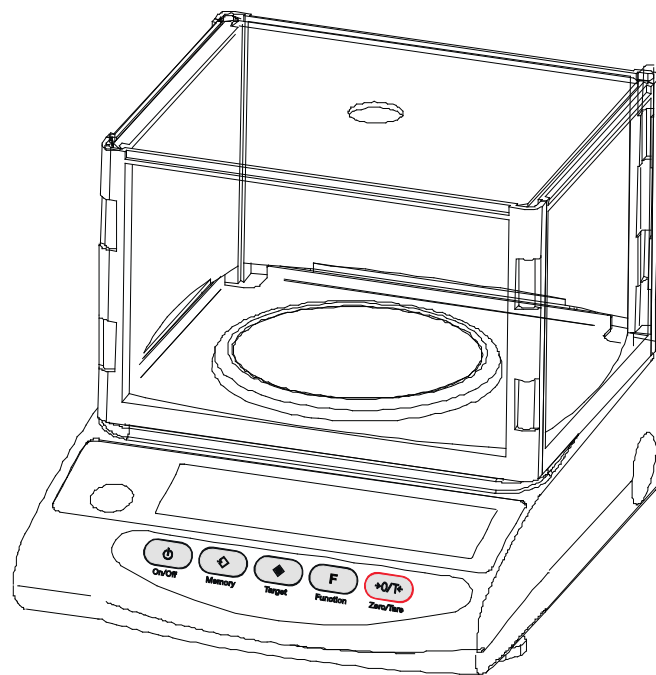

An ISO 9001 registered company
© Rice Lake Weighing Systems. All rights reserved.

Rice Lake Weighing Systems® is a registered trademark of
Rice Lake Weighing Systems.
All other brand or product names within this publication are trademarks or
registered trademarks of their respective companies.

All information contained within this publication is, to the best of our knowledge, complete and accurate at the time of publication. Rice Lake Weighing Systems reserves the right to make changes to the technology, features, specifications and design of the equipment without notice.

The most current version of this publication, software, firmware and all other product updates can be found on our website:

www.ricelake.com

Contents

1.0	Introduction	1
1.1	Standard Features	1
1.2	Component Parts	1
1.3	Safety	2
1.4	Tuning Fork Precision Electronic Balance	3
1.5	LCD Indicator Display	4
1.6	Operating Keys	5
2.0	Assembly	6
3.0	Operation	8
3.1	Basic Startup	8
3.2	Tare	8
3.3	Counting	9
3.3.1	Sampling	9
3.3.2	Increasing the Counting Accuracy (Memory Update Method)	10
3.4	Measuring	11
3.5	Battery Operation	11
3.5.1	Specifications	11
3.5.2	Charging Method	11
3.5.3	User Precautions	12
4.0	Functions Setup	13
4.1	Functions	13
4.1.1	Interface Section	15
4.2	Switching Functions	15
4.2.1	Setup of Units of Measurement	15
4.3	Limit Function	16
4.3.1	Limit Value Input Methods	16
4.3.2	Indication of Judgment Result	16
4.3.3	Limit Function Setup	16
4.3.4	Setup of Limit Values by Actual Quantity Loads	17
4.3.5	Setting up Limit Values by Inputting Values	17
4.4	Input/Output Functions	18
4.4.1	Connection Between Balances and Personal Computers	19
4.4.2	Interface Specifications	20
4.4.3	Output Data	20
4.4.4	Input commands	21
4.4.5	Response Output	22
5.0	Calibration	23
5.1	Calibration of TP Series	23
6.0	Maintenance	24
6.1	Troubleshooting	24
6.2	Specifications	25
6.2.1	Common Specifications	25
6.2.2	Minimum Display by Unit of Measurement	26
6.2.3	Conversion Table of Units	27
6.3	NTEP Sealing and Operation	28

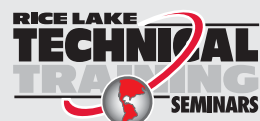

Technical training seminars are available through Rice Lake Weighing Systems. Course descriptions and dates can be viewed at www.ricelake.com/training or obtained by calling 715-234-9171 and asking for the training department.



Rice Lake continually offers web-based video training on a growing selection of product-related topics at no cost. Visit www.ricelake.com/webinars

1.0 Introduction

The simple, straightforward design of Rice Lake's TP Series balance creates for an effortless user experience. Equipped with the unique Mono-Metal Tuning Fork Sensor (MMTS), this balance series brings remarkable response time and exceptional stability to any setting.

Functions that are easy to use and understand come standard with the TP Series balance. Enhance productivity with modes such as unit counting and percentage weighing. Adapt to any type of standard with the ability to weigh in 12 different measurement units.

The compact and manageable size of the TP Series balance is suitable for even the most limited of space. A footprint smaller than a sheet of paper makes it perfect for crowded work environments.

Each balance performs with incredible sensitivity and stability by relying on its dynamic tuning fork sensor. Plug in and start weighing without waiting for stabilization.



Manuals are available for viewing and/or downloading from the Rice Lake Weighing Systems website at www.ricelake.com/manuals

Warranty information can be found on the website at www.ricelake.com/warranties

1.1 Standard Features

- External weight calibration
- Large 16.5 mm high liquid crystal backlight display
- Selectable modes: weight, unit, count and percentage
- 12 units of measurement
- Mono-Metal Tuning Fork Sensor (MMTS) provides quick response and stability
- 20-step bar graph display
- 115 VAC adapter included (230 VAC optional)
- RS-232 bidirectional
- Plastic housing on models less than 1000 g; plastic top and die cast housing on models greater than 1000 g

Part No.	Model No.	Description	NTEP Resolution
108155	TP-420NT	420g x 0.001g	(e=0.01g)
163604	TP-1200NT	1200g x 0.01g	(e=0.1g)
108154	TP-4200NT	4200g x 0.01g	(e=0.1g)
163606	TP-6200NT	6200g x 0.01g	(e=0.1g)

Table 1-1. Part Number Information

1.2 Component Parts

Round-pan types: TP-220, TP-320, TP-420(NT), TP-620

Square-pan types: TP-820, TP-1200(NT), TP-2200, TP-3200, TP-4200(NT), TP-6200(NT), TP-8200, TP-12K

1.3 Safety

Safety Signal Definitions:



Indicates an imminently hazardous situation that, if not avoided, will result in death or serious injury. Includes hazards that are exposed when guards are removed.



Indicates a potentially hazardous situation that, if not avoided could result in serious injury or death. Includes hazards that are exposed when guards are removed.



Indicates a potentially hazardous situation that, if not avoided, could result in minor or moderate injury.



Indicates information about procedures that, if not observed, could result in damage to equipment or corruption to and loss of data.

General Safety



Do not operate or work on this equipment unless this manual has been read and all instructions are understood. Failure to follow the instructions or heed the warnings could result in injury or death. Contact any Rice Lake Weighing Systems dealer for replacement manuals.



Failure to heed could result in serious injury or death.

Before attempting to operate this unit, make sure every individual who operates or works with this unit has read and understands the following safety information.

Failure to heed may result in serious injury or death.

Do not allow minors (children) or inexperienced persons to operate this unit.

Do not operate without all shields and guards in place.

Do not jump on the scale.

Do not use for purposes other than weight taking.

Do not place fingers into slots or possible pinch points.

Do not use any load bearing component that is worn beyond 5% of the original dimension.

Do not use this product if any of the components are cracked.

Do not exceed the rated load limit of the unit.

Do not make alterations or modifications to the unit.

Do not remove or obscure warning labels.

Do not use near water.

Before opening the unit, ensure the power cord is disconnected from the outlet.

Keep hands, feet and loose clothing away from moving parts.

Use only AC power (rated value) and the dedicated AC adapter.

1.4 Tuning Fork Precision Electronic Balance

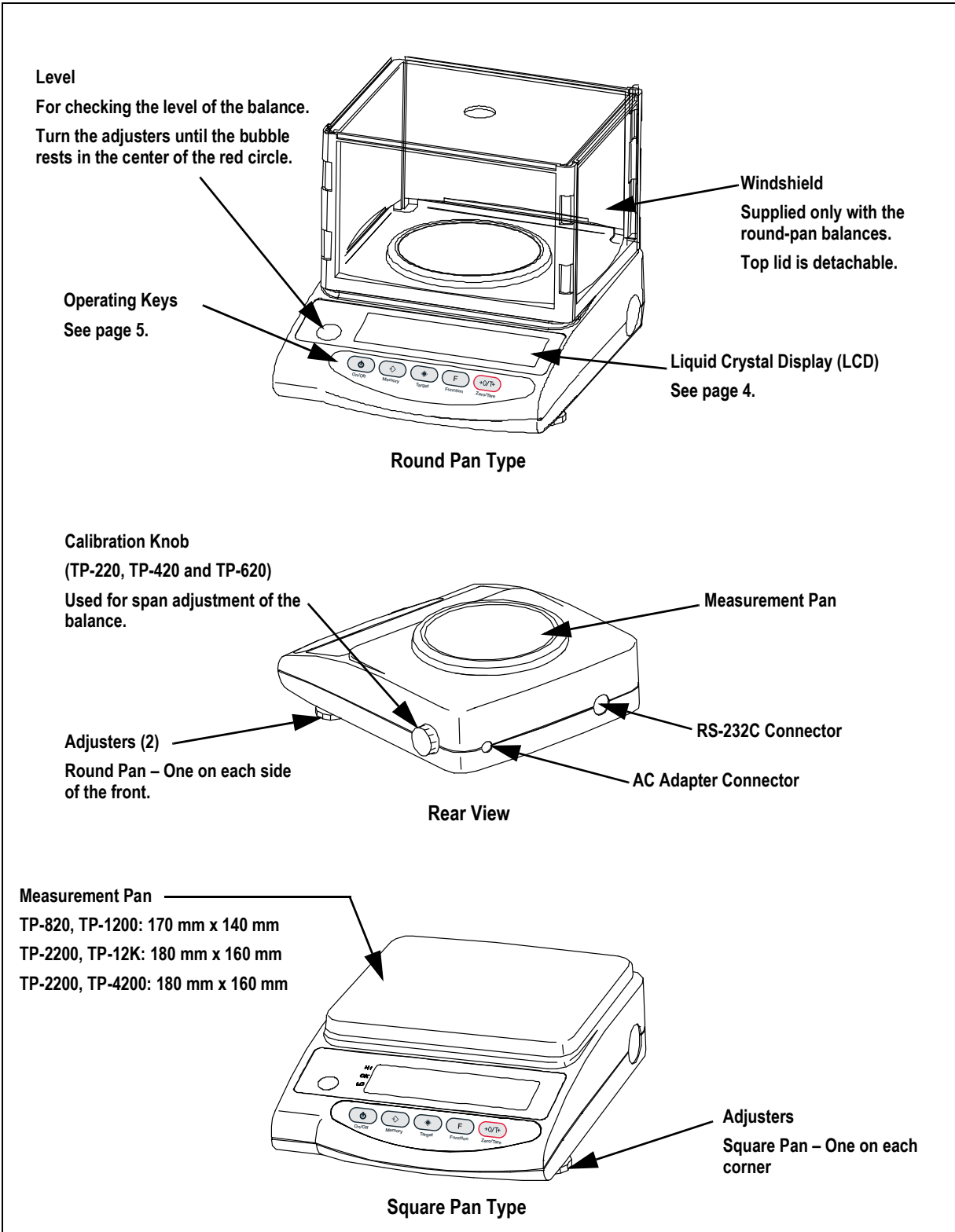

Figure 1-1. Component Locations

1.5 LCD Indicator Display

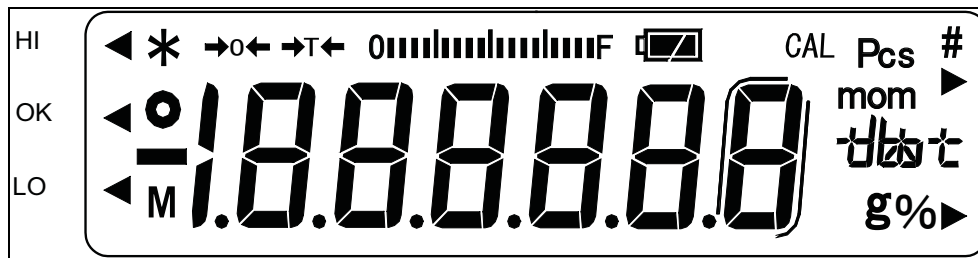

Figure 1-2. LCD Symbols

Display	Description
g	Grams
→0←	Zero point
→T←	Tare being subtracted
	Indication of stable balance (if the light is off, the balance is unstable)
*	Balance powered up (lights up when the power is turned off) or data transmitted
Pcs	Counting mode
%	Percentage mode
◀	Indication of judgment result (HI/OK/LO) when the limit function is active
M	Display of set values from memory (If a value is flashing, it is being saved)
CAL	Stays on and flashes while span adjustment is in progress
	Bar graph
Units selection	ct (ct) carat
	oz (oz) ounce
	Lb (lb) pound
	ozt (ozt) troy ounce
	dwt (dwt) penny weight
	▶ Upper right grain
	tl (tl) tael (Hong Kong)*
	tl ▶ Upper right (tl ▶ Upper right) tael (Singapore, Malaysia)*
	tl ▶ Lower right (tl ▶ Lower right) tael (Taiwan)*
	to (to) tola*
	mom Momme*
	Lit when the balance is battery operated. indicates the battery needs to be charged.
*Not available on NTEP models	

Table 1-2. Symbols Descriptions

1.6 Operating Keys











Non-NTEP Operating Key	NTEP Operating Key	Operating Key Definition	Function
 Power	 ON/OFF	On/Off Key	Key to turn on/off the unit power.
 Memory	 Memory	Memory Key	Brief press – Initiates print or output. Brief press – Saves the settings of the number of pieces or percentages (%) or the limit value when using the limit function.
 Target	 Set	Target/Set Key	Brief press – Starts setting the number of pieces or percentages (%). Continuous press – Starts setting the limit value when using the limit function.
 Function	 Function	Function Key	Brief press – Toggle switches the units to be displayed in succession (g, Pcs, %, etc). Brief press – Moves the flashing digit in the setup of a limit value when using the value input method. Brief press – Selects an parameter when setting the function. Continuous press – Invokes various functions. Longer Continuous press – Invokes span adjustment.
 Zero/Tare	 Zero	Zero/Tare Key	Brief press – Resets the indication to zero when using zero-point setup or tare subtraction. Brief press – Selects a value with the value input method when using the limit function. Brief press – Selects a function when operating the balance in the function mode.

Table 1-3. Operation Keys

2.0 Assembly

Use the following steps to assemble a *TP Series Balance*.

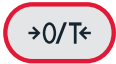
1. Mount the pan base on the main unit of the balance and place the measurement pan on top of it. Be sure to mount the pan base in the correct direction as illustrated.

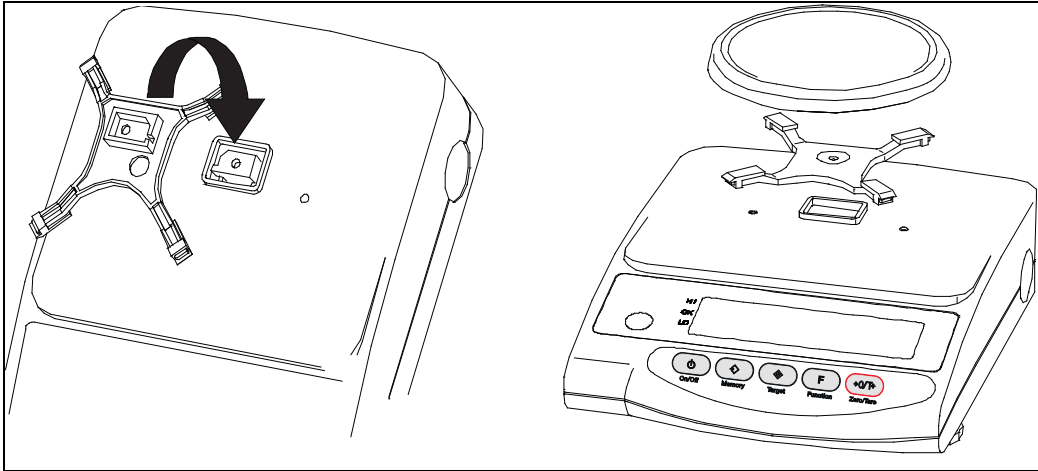

Figure 2-1. Mount Pan Base with Measurement Pan

2. Insert a small panel into a large panel – the edge with the step should face the same side.
3. Connect the other large panel to the two that are assembled.
4. Connect the last panel to the assembly.

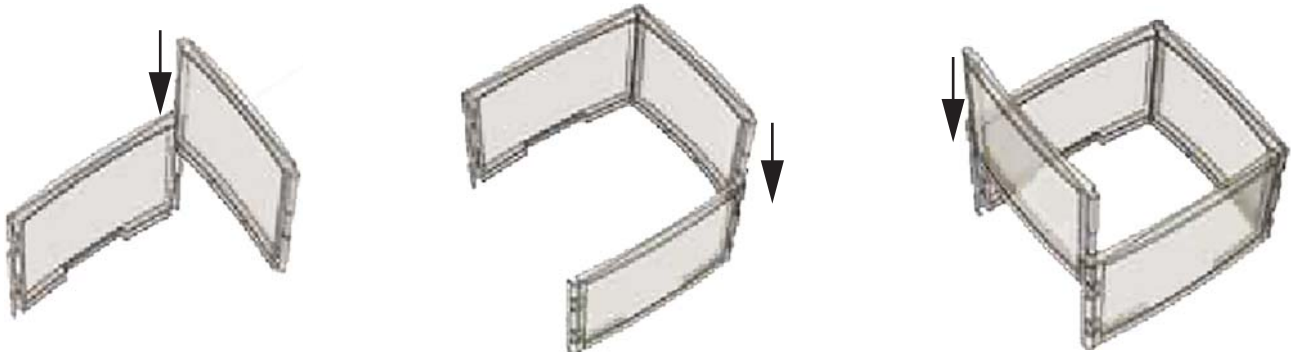

Figure 2-2. Assemble Guard

5. Put the cover on top of the balance and place the complete assembly along the guide.
6. Level the balance by turning the adjustable feet until the bubble rests in the center of the red circle.
 - Round-pan type: two adjustable feet, one on each side at the front of balance.
 - Square-pan type: four adjustable feet, one on each side at the front and rear of balance.



Figure 2-3. Level Balance



Use caution when turning the feet on the square-pan model to prevent them from lifting up.

7. Connect the AC adapter to the balance.

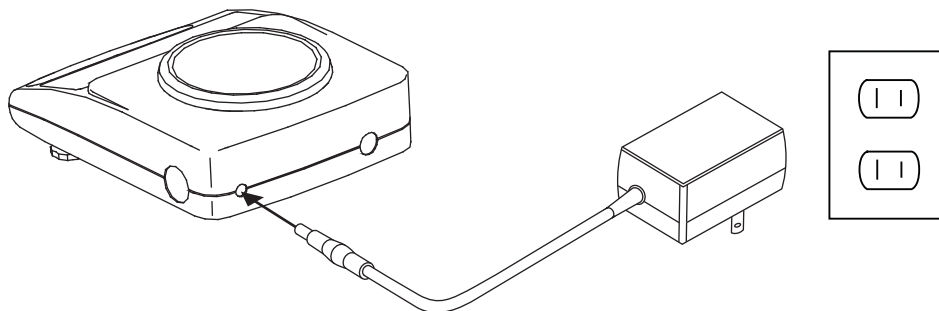



Figure 2-4. Connect AC Adapter



Note *If the balance is battery operated, refer to [Section 3.5 on page 11](#).*

3.0 Operation

 **Note** Key representations may differ depending on whether the NTEP or non-NTEP version of the scale is in use.

3.1 Basic Startup

Once the AC adapter is connected to the balance, * displays.

1. Press . The display section lights up and the balance is ready for operation.
2. Check the indicator display for missing or unlit icons. A few seconds after startup the display resets to zero.

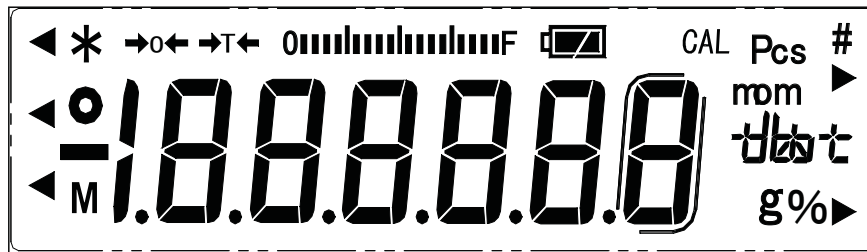



Figure 3-1. Display Icons

3. Press  to switch the measurement mode. The unit of measurement changes each time the key is pressed.

 **Note** The balance is shipped from the factory with the following unit sequence:

[g] → [ct] → [Pcs] → [%] → [g] → ...

4. Press the measurement pan lightly and ensure that the display changes.
5. Release and ensure that the read-out indicator resets to zero.

3.2 Tare

1. Place a container on the balance. The balance indicates the weight of the item.
2. Press  to tare the weight of the item. The weight (tare) is subtracted and the balance indicates zero.
3. Load the sample to be weighed. The balance indicates only the weight of the sample loaded in the container.

Determining the weight of an added sample:

4. Press  to reset the indication to zero. The total weight of the sample loaded on the measurement pan is tared.
5. Load the additional sample. The balance indicates the weight of only the added sample.

 **Note** When the weight of a sample currently loaded on the measurement pan is reset to zero with the Zero/Tare key, only the weight of the newly added sample is measured.

Key Points of the Procedure

The following applies to all measurement modes for weight measurement, counting and percentages.

- After the balance is switched off, there is still enough current to display *****. This indicates that the AC adapter is connected to an electrical outlet, but the balance is turned off. When the balance is switched on again, ***** turns off.



Note *If the balance is running on batteries and the unit is switched off, ***** does not display.*

- The bar graph shows the current load status with respect to the capacity of the balance. As the F annunciator draws near, the smaller the measurable weight becomes.



Note *A subtracted tare weight is indicated on the bar even when though the display may indicate zero.*

- The stability indicator  is on as long as the balance is stable. It does not display if the balance becomes unstable. When a displayed value flickers or the stability annunciator flashes on and off, it is likely that the balance is being affected by wind or other vibrations. Use the windshield or vibration dampers to protect against such adverse effects.
- When the read-out indicator is reset to zero or the tare is subtracted, the balance displays **→0←**.
If the tare is subtracted, the indicator displays **→T←**.
- When the tare is present, the measurable range is reduced. The measurable range is the capacity minus the tare weight.
- If **0-Err** displays when a sample is loaded, the measurable range has been exceeded.
- In counting or percentage mode, the indicator does not change, even when the measurement pan is pressed, if no sample is stored in the memory.
- The active measurement mode on startup is the mode that was active when the balance was last switched off. For example, if the balance was switched off while in counting mode, the balance starts in counting mode the next time it is switched on.

3.3 Counting

To implement piece counting, the specified samples are loaded on the balance and their average unit weight (here after, referred as unit weight) is entered and saved. The procedure for saving unit weights is called sampling.

The counting procedure consists of loading articles that have already been sampled onto the balance. The number of pieces is then calculated by dividing the total weight of the loaded articles by the unit weight saved in memory. Piece counting cannot be implemented unless sampling has already taken place.



Note *If samples to be counted deviate widely in weight, or a higher measure of accuracy is desired, see Section 3 on page 10. This procedure results in greater precision by increasing the number of samples used in the sampling operation.*

3.3.1 Sampling

1. Press **F** to display Pcs.
2. Place the tare (measurement pan) and press **→0←**. The tare is subtracted and the balance now indicates zero.
3. Press **S**. The display flashes a number signifying the number of samples to be loaded. The sampling number that was used in the previous sampling is displayed.
4. Press **→0←**. Each press of the key changes the value on the right end. Select the desired value. Continue to step 5 if the sampling number need not to be changed.



Note *If samples to be counted widely deviate in weight, or a higher measure of accuracy is desired, it is recommended that users change the sampling number to a larger value.*

5. Count the samples carefully and load them in the center of the measurement pan.
6. Press **P**. The balance saves the unit weight and reverts to measurement mode.

Key Points of the Procedure

- The value indication turns off and M flashes to indicate that memory saving is underway when samples are being saved. If the balance is affected by wind or other vibrations during this process, the saving time may be prolonged.
- If $L - Err$ displays, it indicates one of the following states:
 - The weight of one sample (measurable unit weight) is insufficient. For the range of unit weights that can be measured and saved.
- In the sampling of Operation Step 3, press **S** with the samples loaded on the balance.



Note

$L - Err$ displays if the sampling is interrupted and the data in progress is not saved.

3.3.2 Increasing the Counting Accuracy (Memory Update Method)

The operation for increasing counting accuracy is referred to as the Memory Update Method. This procedure updates the memory with a unit weight that represents a more precise average by gradually increasing the sampling number. This operation improves counting accuracy and is recommended for the following cases:

- When the samples to be counted deviate widely in weight or the number of samples displayed.
- When greater accuracy is desired.



Note

If Rdd displays in Memory Update Method, it indicates that a counting error is likely due to the small number of the samples loaded on the balance. \blacktriangleleft illuminates at LO. As the memory update continues, counting accuracy improves and the above indication is no longer illuminated.

If the sampling number is changed, subsequent sampling starts from the new sampling number.



Note

This procedure is the same as the sampling procedure described on the previous page, to the point at which the sampling number is changed.

1. Count the samples carefully and load them on to the center of the measurement pan.
2. Press **S**. The unit weight of the sample is saved, and a flashing value displays. This flashing value denotes that the Memory Update method is currently active.
3. Add an approximately equal number of samples as the amount displayed. Add them in groups of about the same number, until the number of samples is approximately double. The additional samples need not be counted.
4. Press **S**. After the unit weight of the samples has been saved, the display begins to flash, indicating that the Memory Update Method is still running.
5. Repeat steps 3 and 4. The total number of samples to be saved should be approximately 1/5 to 1/2 of the number of samples to be measured.
6. Press **P**. The balance saves the unit weight and returns to measurement mode.

3.4 Measuring

The percentage measurement function operates by weighing a reference sample and saving its weight as a reference value and indexing it as 100%. When a measurement sample loaded on the balance is lighter or heavier than the reference, its weight is indicated as a percentage (%) value relative to the reference weight.

1. Press **F** to display %.
2. Press **S**. *P. 5Et* flashes on the display. The balance is now ready for reference value setup.
3. Load the reference sample.
4. Press **P**. The balance indexes the weight value of the reference sample as 100% and returns to measurement mode.
5. The balance now indicates the weight of the loaded sample as a percentage (%) value relative to the reference value.

Key points of the procedure

- While samples are being saved, the value indication turns off temporarily and only M flashes. If the balance is affected by wind or other vibrations during this process, the saving time may be prolonged.
- The minimum intervals between percentages in the unit switch from 1% to 0.1% to 0.01% depending on the reference weight from the sampling.
- If *L - Err* displays briefly, it indicates one of the following states:
 - The weight of the reference sample is insufficient. For the limit weight that can be saved (% limit weight).
 - While setting up the reference value in Step 2, **S** was pressed when the samples were loaded on the balance.



Note If *L - Err* displays, sampling has been interrupted and the sample value being processed is not saved.

3.5 Battery Operation

Information in this section applies only when the balance is battery operated.

3.5.1 Specifications



Built-in nickel-cadmium battery

Charging time Approximately 12 hours

Drive time Approximately 24 continuous hours

Number of charge/discharge cycles 300 or more

3.5.2 Charging Method



While the balance is battery-operated, the full battery indicator  stays on. The charging required indicator  flashes when the battery capacity decreases. If the balance flashes , charge the battery by following these steps:

1. Connect the dedicated AC adapter to the balance.
2. Turn off the balance.
3. Charge the battery for approximately 12 hours, with the power switched off.



Note Charging the battery longer than 12 hours decreases battery life.

3.5.3 User Precautions

- Once charging is complete, use the balance without the AC adapter to avoid over-charging. This can occur since the balance continues to charge the battery with a weak current when the power is switched on. Overcharging also decreases battery life.
- When the balance is used for the first time after purchase, the operating time may be shorter than when using a fully charged battery. This is due to natural discharge of the battery. Although the balance can be used while  is flashing, it should be recharged as soon as possible.
- When the battery displays no indication, or an indication turns off quickly after the balance is switched on, battery capacity is low. In these cases, either charge the battery immediately, or plug in the AC adapter.
- Charging the battery while  is displayed reduces battery life.



Observe the following to operate the balance safely; failure to do so could result in malfunctions, breakage, burst batteries, or fire:

Do not disassemble or modify the battery.

Do not reverse the balance connection or short-circuit the positive and negative polarities of the balance.

Use only the supplied AC adapter.

Do not incinerate used batteries. Dispose as hazardous material only.

4.0 Functions Setup

4.1 Functions

1. Press and hold **F** until *Func* displays, then release the key. The function setup mode is activated and the first parameter, *1. b. G. 1* (Bar graph) displays. See [Table 4-1](#).
2. Press **F**. *2. SEL 0* (Limit Function) displays.
3. Press **F** to advance through the function parameters.
4. Select the parameter to be changed with **F**. Each press of **→0←** changes the digit on the right end. Select the desired digit.
5. Press **S**. The balance terminates the Function setup and returns to measurement mode.

Parameter	Settings	Description
Bar graph display	<i>1. b. G. 0</i>	Disable
	<i>1*</i>	Enable
Limit function	<i>2. SEL 0*</i>	Disable
	<i>1</i>	Enable
Judgment Condition Displayed only when limit function is activated	<i>2 1. 0 0</i>	<i>1*</i> Always judge (judges even when the balance is unstable).
		<i>2</i> Judge only when the balance is stable (does not judge if the balance is unstable).
Judgment Range Displayed only when limit function is activated	<i>22. L 0</i>	Ranges beyond +5 graduation is judged (ranges +5 graduation or below, including negative ranges, are not judged.).
	<i>1*</i>	The entire range is judged (the entire range, including the negative, is judged).
Number of points for Judgment Displayed only when limit function is activated	<i>23. P 1*</i>	One-point setup (judges between OK and LO).
	<i>2</i>	Upper-limit and lower-limit values are set up (judges among HI, OK and LO).
Auto-zero (zero-tracking)	<i>3. R. 0 0</i>	Disable This function automatically sets the zero point exactly to zero to prevent slight deviations.
	<i>1*</i>	Enable This function automatically sets the zero point exactly to zero to prevent slight deviations.
Auto power-off	<i>4. R. P 0</i>	Disable (balance operates continuously) This function is available only when the balance is battery-operated.
	<i>1*</i>	Enable (balance powers off in approximately three minutes) This function is available only when the balance is battery-operated.
Response speed	<i>5. rE 0</i>	Measurement by consecutive weighings.
	<i>1</i>	Fast
	<i>2</i>	
	<i>3*</i>	
	<i>4</i>	
	<i>5</i>	Slow

Table 4-1. Description of Functions

Parameter	Settings	Description	
Stability parameters	6. 5. d	1	Wide (mild)
		2*	
		3	
		4	Narrow (strict)
Interface	7. 1. F.	0	Disable input/output.
		1*	Six-digit numeric format.
		2	Seven-digit numeric format.
Setup of measurement units to be displayed. Press F to navigate through unit options.	8 1. 5. U. 5 85. 5. U.	1* 0 1	g (g)
		2* 14	ct (ct)
		15	oz (oz)
		16	lb (lb)
		17	ozt (ozt)
		18	dwt (dwt)
		19	▶ Lower right (grain)
		1A	tl (tl_Hong Kong)**
		1b	tl ▶ Upper right (tl_Singapore, Malaysia)**
		1C	tl ▶ Lower right (tl_Taiwan)**
		1d	mom (momme)**
		1E	to (to)**
		3* 02	Pcs
		4* 1F	%
5* 00	Unit not set		

Table 4-1. Description of Functions (Continued)

Default factory settings; 1-5*: Default settings [8 1. 5. U.] ~ [85. 5. U.]

**Not available on NTEP models

4.1.1 Interface Section

Displayed when 7.1.F is set to 1 or 2.

Parameter	Settings	Description	
Output Control	7.1.O.C	0	Stop output.
		1	Output continuous at all times.
		2	Output continuous if stable (stops output if unstable).
		3	Outputs once by pressing P (irrespective of whether stable).
		4	Outputs once, if stable. Outputs if the balance is stable when a sample is loaded after the preceding sample has been removed and the balance indicated zero, or less.
		5	Outputs once if stable, and stops output when unstable.
		6	Outputs once if stable, and outputs continuously when unstable. Even if the sample is not replaced, output of the balance stops when it stabilizes after being output once.
		*7	Pressing P causes the balance to output once when stable.
Baud Rate	7.2.B.1	*1	1200 bps
		2	2400 bps
		3	4800 bps
		4	9600 bps
Parity	7.3.P.1	*0 None	Displayed only when 7.1.F.2 (7-digit numeric format) is specified.
		1 Odd	
		2 Even	

Table 4-1. Interface Settings

* Denotes a factory setting

The data interval in continuous output mode is 0.1 to 1 second (the interval varies depending on weighing conditions and other factors).

4.2 Switching Functions

Pressing **F** allows the user to switch the unit of measurement to g, ct, %, and so on. During setup, a maximum of five different units can be registered for use in function setup mode.

To switch the units of measurement to be displayed, press **F**. Each press advances through the units of measurement to be displayed.

4.2.1 Setup of Units of Measurement

When values B1.S.U. to B5.S.U. are entered prior to use, the desired unit of measurement to be displayed can be chosen simply by pressing **F**.

Example:

To change the default factory settings to pound units, use B2.S.U. in the factory settings.

1. Press and hold down **F**.
2. Release the key as FUnc displays. The function setup mode is now activated and the first parameter is displayed.

3. Press **F** several more times, until $B2.5.U.14$ displays.
4. Press **→0←** several times to specify $B2.5.U.15$.
5. Press **S** to reset the measurement mode.
6. Press **F**. Each press of the key changes the units of measurement to be displayed as follows: g, lb, Pcs, %, g...

Key Points of the Procedure

- When set values are entered in the function parameters $B1.5.U.$ to $B5.5.U.$ prior to use, the desired unit of measurement to be displayed can be selected by simply pressing the Function key.
- The units are displayed in the same sequence as the settings made from $B1.5.U.$ to $B5.5.U.$.
- If 00 is set, no unit of measurement is displayed, even when units of measurement are set in subsequent parameters.
- 00 cannot be set in $B1.5.U.$.
- If the same unit of measurement is set multiple times, the second time (and all subsequent times) the unit(s) occurs, it is ignored when the display switches.

4.3 Limit Function

The limit function judges measurements according to a limit value saved in the balance. The function shows the judgment result by displaying the ◀ annunciator as either HI (excessive), OK (appropriate), or LO (insufficient). This function is useful when discriminating between conforming and nonconforming articles. It is also useful when measuring a given constant quantity consecutively, in conjunction with a range of reference weights defined by upper- and lower-limit values.

This function can be used in weight mode, counting mode, or percentage mode.

4.3.1 Limit Value Input Methods

Either of the following two methods can be used in the different modes:

- Actual Quantity Setup Method - An actual sample is loaded on the balance; its weight is saved as the limit value.
- Numeric Value Setup Method - The limit value is entered with any key stroke.



Note

The limit values entered are held in memory, even when the balance is powered down. The respective limit values for weight mode, counting mode and percentage mode are set up independently.

4.3.2 Indication of Judgment Result

The ◀ annunciator lights up as either HI, OK or LO on the left side of the display, indicating the result of judgment.

Judgment Results	Upper/Lower Limit Setting	One-Point Setting
HI (excessive)	Upper-limit value < measurement value	No indication
OK (appropriate)	Upper-limit value \geq measurement value \geq lower-limit value	Limit value \leq measurement value
LO (insufficient)	Lower-limit value > measurement value	Limit value > measurement value

4.3.3 Limit Function Setup

1. To start the function, press and hold down **F** until $FUNC$ displays. The display changes to the function setup and the first parameter is displayed.
2. To select a function parameter, press **F**. The display changes to the next parameter, Limit Function.

3. Press **→0←** to set the value on the right most side to 1.
4. Press **F**. The display changes to *Judgment Condition*.
5. Press **→0←** to select the desired condition.
6. Press **F**. The display changes to *Judgment Range*.
7. Press **→0←** to select the desired choice.
8. Press the **Set** key. The balance terminates the function setup and returns to measurement mode.

4.3.4 Setup of Limit Values by Actual Quantity Loads

1. Press and hold **S**.
2. Release the key when *L. SEE* is displayed. The currently set lower-limit flashes.
3. Load the sample of the lower-limit value on the measurement pan.
4. Press **P**. After the lower-limit value has been saved, the balance displays it briefly and proceeds to the following setup.



Note *If One-Point setup was chosen, the setup is complete.*

5. The display changes to *H. SEE*, indicating that the upper-limit value can be set. The currently set upper-limit value flashes.
6. Load the sample of the upper-limit value on the measurement pan.
7. Press **P**.
8. After saving the upper-limit value, the balance displays it briefly and terminates the setup.

4.3.5 Setting up Limit Values by Inputting Values

1. Press and hold down **S**.
2. Release the key when *L. SEE* is displayed. The currently set lower-limit value flashes.
3. Press **→0←**. Once all the digits are displayed, the flashing digit on the right can be changed.
4. Press **→0←** repeatedly until the desired value of the flashing digit is entered.
5. Press **F**. The flashing digit moves one position to the left with each press of **F**. When the left most digit is selected, the flashing digit advances to the rightmost digit position after pressing **F**.
6. Enter the lower-limit value by selecting a value with **→0←** and moving the digits with **F** as needed.
7. The display changes to *H. SEE*, indicating that the upper-limit value can be set. If there is an upper-limit value already

set, that value is flashing.

8. Press **→0←**. Return to step 2 and follow the same procedure as described for the lower-limit value to enter the upper-limit value.
9. Press **P**. After saving the upper-limit value, the balance displays it briefly and terminates setup.

Key Points of the Procedure

- The limit values that are set can be checked by pressing **S**. The balance displays the lower-limit value after showing *L. 5E±* and the upper-limit value after showing *H. 5E±*.
- If a mistake is made, press **F** during the setup of actual quantities or **S** during the setup of values.
- If **P** is pressed while a value is flashing, an actual quantity is set based on the weight currently loaded on the balance. Press **→0←** at this time to display the value input screen.
- If **◀** is illuminated for all three judgment indicators (HI, OK and LO), the lower limit value set exceeds the upper-limit value. Check the values, since mistakes can occur with entries, as in cases when the upper-limit value is specified with a negative sign.
- When M is flashing on the value input screen, the sign on the left end can be changed. Press **→0←** to switch between the positive and negative signs.

4.4 Input/Output Functions

Terminal Number	Signal	Input/Output	Function & Remarks
1	EXT.TARE	Input	External tare subtraction
2	DTR	Output	High (when balance is powered-up)
3	RXD	Input	Receiving data
4	TXD	Output	Transmitting data
5	GND	—	Signal ground

Figure 4-1. Terminal Numbers and Functions

Compatible plug: TCP 0556-01-0201 (Hosiden - supplied with balance)



Note

Tare subtraction (zero adjustment) is possible by connecting an external tare subtraction input and a signal ground through contacts or a transistor switch. When following this procedure, secure a connection time of at least 400 milliseconds. When the switch is off, the voltage maximum is 15 V; when the switch is on, the sink current is 20 mA or less.



CAUTION Before plugging in the connectors, unplug the AC adapter.

4.4.1 Connection Between Balances and Personal Computers

Sample connection with an IBM-PC/AT compatible:

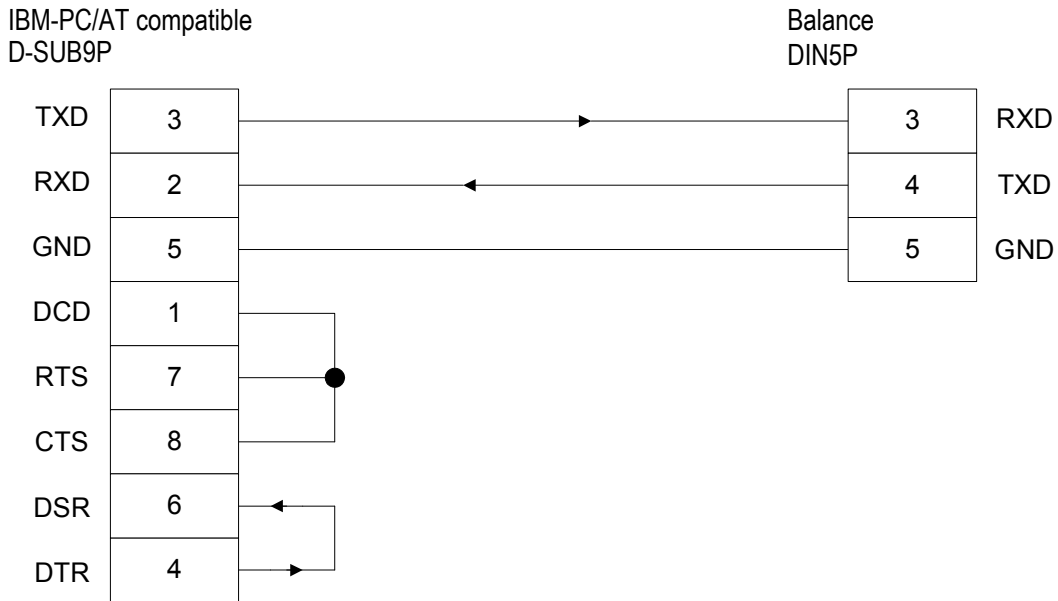

Sample connection with PC9801:

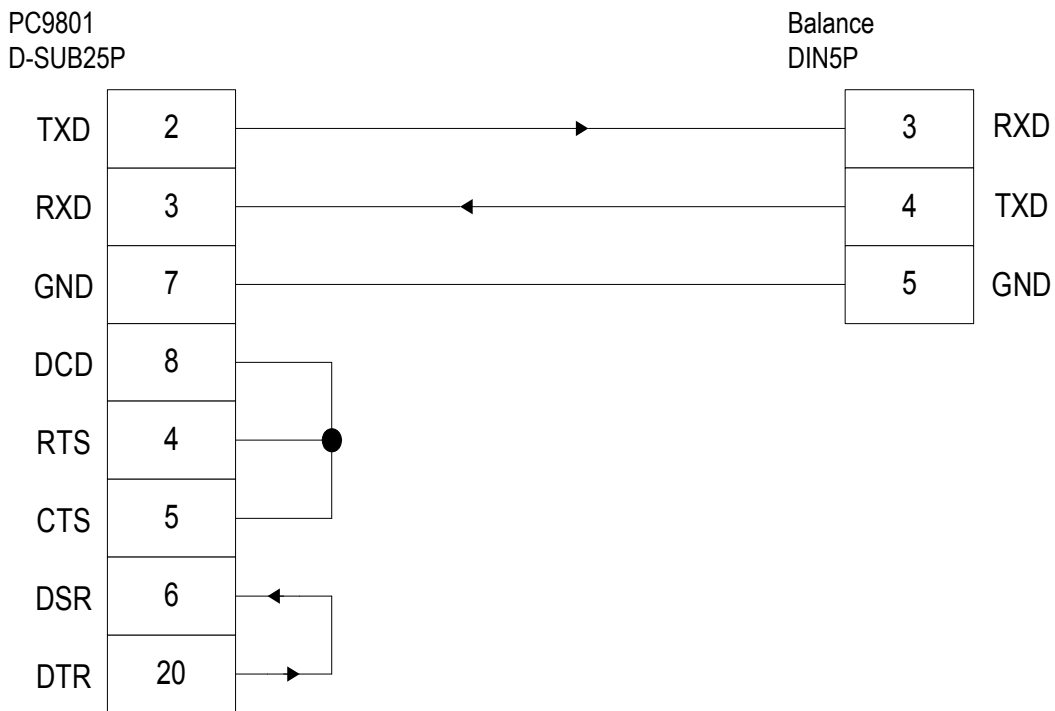

4.4.2 Interface Specifications

1	Transmission System	Serial transmission with start-stop synchronization
2	Transmission rates	1200/2400/4800/9600 bps
3	Transmission codes	ASCII codes (8-bit)
4	Signal levels	Compliant with EIA RS-232C HIGH level (Data logic 0) +5 to +15 V LOW level (Data logic 1) -5 to -15 V
5	One-character bit configuration	Start bit: 1 bit Data bit: 8 bits Parity bit: 0/1 bits Stop bit: 2 bits
6	Parity bit	None/odd/even

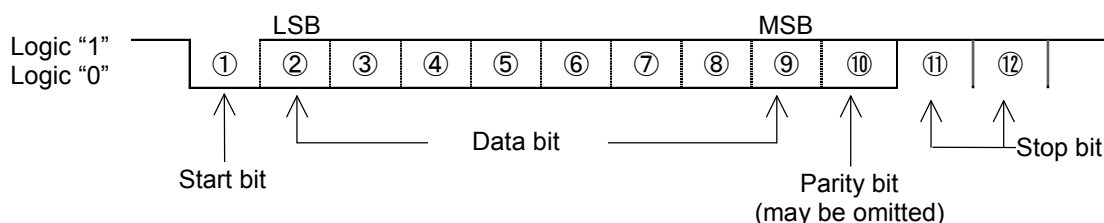

4.4.3 Output Data

Data Format

By changing the function settings on the main unit of the balance, users can select either a six-digit numeric format or a seven-digit numeric format.

- Six-digit numeric format is composed of 14 character pairings, including the terminators CR=0DH, LF=0AH.

1	2	3	4	5	6	7	8	9	10	11	12	13	14
P1	D1	D2	D3	D4	D5	D6	D7	U1	U2	S1	S2	CR	LF

- Seven-digit numeric format is composed of 15 character pairings, including the terminators CR=0DH, LF=0AH. A parity bit can also be appended.

1	2	3	4	5	6	7	8	9	10	11	12	13	14	15
P1	D1	D2	D3	D4	D5	D6	D7	D8	U1	U2	S1	S2	CR	LF

Polarities (P1: one character)

P1	Code	Description
+	2BH	When data is zero or positive
-	2DH	When data is negative
(SP)	20H	When data is zero or positive

Numeric Data

Six-digit numeric format (D1-D7; seven characters)

Seven-digit numeric format (D1-D8; eight characters)

D1-D7 (D8)	Code	Description
0-9	30H-39H	Numerical value 0-9
.	2EH	Decimal point (floating position) <i>NOTE: When the data is an integer, it may be omitted and replaced with a blank space (SP) in the lowest-order place.</i>
(SP)	20H	Space: zero of leading portion of value (leading zero suppress)

Units (U1, U2: Two Characters)

All codes are ASCII codes.

U1	U2	Code		Description	Balance Indicators
(SP)	G	20H	47H	Gram	g
C	T	43H	54H	Carat	ct
O	Z	4FH	5AH	Ounce	oz
L	B	4CH	42H	Pound	lb
O	T	4FH	54H	Troy Ounce	oz t
D	W	44H	57H	Pennyweight	dwt
G	R	47H	52H	Grain	▶ (lower right)
T	L	54H	4CH	tael (Hong Kong)	tl
T	L	54H	4CH	tael (Singapore, Malaysia)	tl ▶ (upper right)
T	L	54H	4CH	tael (Taiwan)	tl ▶ (lower right)
M	O	4DH	4FH	Momme	Mom
t	o	74H	6FH	Tola	to
(SP)	%	20H	25H	Percentage	%
P	C	50H	43H	Pieces	Pcs

Result of Judgment when operating the balance with the limit function (S1: One Character)

S1	Code	Description
L	4CH	LO (Low)
G	47H	OK (Good)
H	48H	HI (High)
(SP)	20H	No limit value specified

Status (S2: One Character)

S2	Code	Description
S	53H	Data stable
U	55H	Data unstable
E	45H	Data error (data other than S2 is invalid)
(SP)	20H	No status specified

4.4.4 Input commands

Users can control the balance remotely by transmitting commands from an external device. Two types of control commands are available: instruction for tare subtraction and setup of output control.

Command Transmission Method

1. A command is transmitted to the balance from an external device. Since the data flow (transmission and reception) is stored by a full-duplex system, commands can be transmitted regardless of their data transmission timing.
2. When the balance has executed the received command, it activates a normal end response or transmits the requested data via the transmitting command. If the balance was unable to execute the command or received an erroneous command, it transmits an error and response. If the balance is working properly, it usually returns a response within a second after it receives the transmitted command. If the balance receives a transmission while it is conducting a procedure (such as the setup of a function or a span adjustment), it will transmit a response when the procedure finishes.

- When transmitting more than one command to the balance from a remote device, wait until a confirmation on the first transmission is received before transmitting the next.

Command Format

- Composed of four characters (ASCII), including the terminators CR=0DH, LF=0AH.

1	2	3	4
C1	C2	CR	LF

- Instruction for tare subtraction (zero adjustment)

C1	C2	Code		Description	Value	Response
T	(SP)	54H	20H	Instruction for tare subtraction (zero adjustment)	None	A00: Normal end E01: Tare subtraction cannot be executed due to an error in the weight value

- Setup of output control

C1	C2	Code		Description
O	0	4FH	30H	Stop output.
O	1	4FH	31H	Output continuous at all times.
O	2	4FH	32H	Output continuous if stable (stop output if unstable).
O	3	4FH	33H	Outputs once by pressing Memory (irrespective of whether stable)
O	4	4FH	34H	Output continuous at all times.
O	5	4FH	35H	Output continuous at all times.
O	6	4FH	36H	Output continuous at all times.
O	7	4FH	37H	Output continuous at all times.
O	8	4FH	38H	Output continuous at all times.
O	9	4FH	39H	Output continuous at all times.



Note

The output controls executed with commands 00 - 07 work the same as the output controls executed through function setup on the main unit of the balance. The commands 08 and 09 are data request commands issued to the balance.

Once any command from 00 - 09 is executed, the balance runs that function until another command is entered. However, if the balance is switched off and on again, the output control is reset to the initial function.

4.4.5 Response Output

- Response output format is composed of five characters, including the terminators (CR=0DH, LF=0AH).

1	2	3	4	5
A1	A2	A3	CR	LF

- Types of response outputs:

A1	A2	A3	Code			Description
A	0	0	41H	30H	30H	Normal end
E	0	1	45H	30H	31H	Command error (Abnormal command received; other errors)

5.0 Calibration

Since electronic balances are affected by gravitational acceleration, they produce different values in various locations. Therefore, before use, balances must be calibrated at the location where they are installed. Calibration is also required after long periods without use, or if a balance begins to produce inaccurate values.

Calibration of a balance, or span adjustment, is required to produce accurate measurements.

5.1 Calibration of TP Series



Note *Span adjustment should be performed with the balance installed perfectly level and without any load on the measurement pan.*

1. Press and hold down **F**.
2. Release the key when the display changes from *FUNC* to *CR*.
3. Press **F** while holding down **→0←**, then release both keys simultaneously. The display flashes *0.0*, indicating that zero-point calibration is underway. Zero-point calibration is finished when the display changes to *0.0*. Proceed to the calibration of the capacity point.
4. Load the calibration weight in the center of the balance. The display flashes, indicating that capacity point calibration is in progress. When the calibration of the capacity point is finished, the original measurement mode is restored.

Key Points of the Procedure

- Pressing **F** in step 2 interrupts the span adjustment and returns to the original measurement mode.
- The calibration weight used for span adjustment should be heavier than half the capacity of the balance. To implement a calibration as precisely as possible, use a weight close to the capacity of the balance.



Note *Calibration weights can be ordered from Rice Lake Weighing Systems.*

- If problems arise during span adjustments, one or more of the following error messages display:
 - *0-Err* - The calibration weight exceeds the capacity of the balance.
 - *1-Err* - The calibration weight is less than half the capacity of the balance.
 - *2-Err* - The difference between before and after calibration values is too large (1.0% or more).



If error messages are displayed, calibration cannot take place. Check the weight and re-calibrate. If the same error continues after repeated calibrations using the correct weight, please contact Rice Lake Weighing Systems.

6.0 Maintenance

6.1 Troubleshooting

Symptom	Cause	Possible Solution
There is no indication on the display	The AC adapter is not connected	Connect the AC adapter
The display is unstable, M remains flashing without charging	The balance is subject to air currents or vibration	See Section 1.1 on page 2.
	The balance is situated on an unstable surface	
	An object is contacting the sample being measured, the measuring pan, or the tare	
Weight indication contains an error	An error was made in the tare subtraction procedure	Review the tare subtraction
	The adjusters remain lifted, resulting in an incorrect level	Check the level
	The indication values are inconsistent after long hours of use, or after being moved to a new location	Execute span adjustment on the balance
The limit function does not work	The limit function is not selected	Check the operation of the limit function
	The limit value has been entered incorrectly	
<i>Rdd</i> displays (◀ and a value flash at LO).	Likely to produce errors in the counting mode because the sample weight is insufficient	Execute the memory update method
<i>o-Err</i> displays before the capacity is reached	Gross weight exceeded the capacity of the balance (weight range = container + weight of sample)	Check the total weight, execute tare subtraction again
	A section of the mechanism is damaged	Contact our technical service division
<i>U-Err</i> is displayed	A foreign object is caught between the measuring pan (pan base) and the balance	Remove the measurement pan and examine the surface beneath it
	A section of the mechanism is damaged	
<i>b-Err</i> is displayed <i>d-Err</i> is displayed	The balance is exposed to static electricity or noise	Contact the Rice Lake technical service division
	The electrical system of the balance is malfunctioning	
During span adjustment (TP): <i>o-Err</i> is displayed <i>l-Err</i> is displayed <i>z-Err</i> is displayed	A weight heavier than the capacity was used	Check that the span adjustment procedure was performed correctly
	The reference weight is less than 50% of the capacity	
	Calibration produced an error of 1.0% or more	
During battery installation the indication turns off and  flashes	The automatic power-off function was activated	Switch on the power again and deactivate automatic power-off if necessary
	The battery capacity is low	Recharge the battery or operate the balance with the AC adapter

6.2 Specifications

Model	TP-220	TP-320	TP-420 (NT)	TP-620	TP-820	TP-1200 (NT)
Capacity g	220	320	420	620	820	1200
Readability g	0.001	0.001	0.001	0.001	0.01	0.01
Measurable unit weight in counting mode g	0.001	0.001	0.001	0.001	0.01	0.01
Minimum weight in percentage mode g	0.1	0.1	0.1	0.1	1	1
Weight measuring method	Tuning fork vibration method					
Calibration method	With external calibration weight					
Pan size mm	φ 118				170 x 140	
Output	Compliant with RS232 C					
Windshield	Provided				Not provided	

Model	TP-2200	TP-3200	TP-4200 (NT)	TP-6200 (NT)	TP-8200	TP-12K
Capacity g	2200	3200	4200	6200	8200	12000
Readability g	0.01	0.01	0.01	0.01	0.1	0.1
Measurable unit weight in counting mode g	0.01	0.01	0.01	0.01	0.1	0.1
Minimum weight in percentage mode g	1	1	1	1	10	10
Weight measuring method	Tuning fork vibration method					
Calibration method	With external calibration weight					
Pan size in mm	180 x 160					
Output	Compliant with RS232 C					
Windshield	Not provided					

6.2.1 Common Specifications

Tare subtraction range	Total capacity
Liquid-crystal display (LCD)	Seven segments (two segments in leading part), Maximum digits indication: seven digits, Segment height: 16.5 mm
Measuring function	Weight mode, counting mode and percentage mode
Overload indication	Err is displayed if weight capacity + 9 intervals are exceeded
Compatible printer	CSP-160
Operating temperature and humidity ranges	5°C to 35°C, 80% RH or less
AC Adapter	Dedicated AC adapter: 120 V (AC) -9 V (DC), or 230 V (AC) - 9 V (DC)

6.2.2 Minimum Display by Unit of Measurement



Note Upper cell represents capacity, lower cell represents readability.
*Not available on NTEP (NT) models.

Unit of Measurement	TP-220	TP-320	TP-420 (NT)	TP-620	TP-820	TP-1200 (NT)
g (g)	220	320	420	620	820	1200
	0.001	0.001	0.001	0.001	0.01	0.01
ct (ct)	1100	1600	2100	3100	4100	6000
	0.01	0.01	0.01	0.01	0.05	0.05
oz (oz)	7.7	11	14	21	28	42
	0.00005	0.0001	0.0001	0.0001	0.0005	0.0005
lb (lb)	0.48	0.70	0.92	1.3	1.8	2.6
	0.00001	0.00001	0.00001	0.00001	0.00005	0.00005
ozt (ozt)	7	10	13	19	26	38
	0.00005	0.0001	0.0001	0.0001	0.0005	0.0005
dwt (dwt)	140	200	270	390	520	770
	0.001	0.001	0.001	0.001	0.01	0.01
▶ (grain)	3300	4900	6400	9500	12000	18000
	0.02	0.02	0.02	0.02	0.2	0.2
LT (TL - Hong Kong)*	5.8	8.5	11	16	21	32
	0.00005	0.00005	0.0001	0.0001	0.0005	0.0005
LT (Singapore, Malaysia)*	5.8	8.4	11	16	21	32
	0.00005	0.00005	0.0001	0.0001	0.0005	0.0005
LT (Taiwan)*	5.8	8.5	11	16	21	32
	0.00005	0.00005	0.0001	0.0001	0.0005	0.0005
mom (momme)*	58	85	110	160	210	320
	0.0005	0.0005	0.001	0.001	0.005	0.005
to (to)*	18	27	36	53	70	100
	0.0001	0.0001	0.0001	0.001	0.001	0.001

Table 6-1. Minimum Display by Unit of Measurement

Unit of Measurement	TP-2200	TP-3200	TP-4200(NT)	TP-6200(NT)	TP-8200	TP-12K
g (g)	2200	3200	4200	6200	8200	12000
	0.01	0.01	0.01	0.01	0.1	0.1
ct (ct)	11000	16000	21000	31000	41000	60000
	0.1	0.1	0.1	0.1	0.5	0.5
oz (oz)	77	110	140	210	280	420
	0.0005	0.001	0.0001	0.001	0.005	0.005
lb (lb)	4.8	7.0	9.2	13	18	26
	0.0001	0.0001	0.0001	0.0001	0.0005	0.0005
ozt (ozt)	70	100	130	190	260	380
	0.0005	0.001	0.001	0.001	0.005	0.005
dwt (dwt)	1400	2000	2700	3900	5200	7700
	0.01	0.01	0.01	0.01	0.1	0.1
▶ (grain)	33000	49000	64000	95000	120000	180000
	0.2	0.2	0.2	0.2	2	2

Table 6-1. Minimum Display by Unit of Measurement (Continued)

Unit of Measurement	TP-2200	TP-3200	TP-4200 (NT)	TP-6200 (NT)	TP-8200	TP-12K
Ⓕ (Hong Kong)*	58	85	110	160	210	320
	0.0005	0.0005	0.001	0.001	0.005	0.005
Ⓕ (Singapore, Malaysia)*	58	84	110	160	210	310
	0.0005	0.0005	0.001	0.001	0.005	0.005
Ⓕ (Taiwan)*	58	85	110	160	210	320
	0.0005	0.0005	0.001	0.001	0.005	0.005
mom (momme)*	580	850	1100	1600	2100	3200
	0.005	0.005	0.01	0.01	0.05	0.05
Ⓕ (to)*	180	270	360	530	700	1000
	0.001	0.001	0.001	0.01	0.01	0.01

Table 6-1. Minimum Display by Unit of Measurement (Continued)

6.2.3 Conversion Table of Units

Unit	Gram	Carat	Ounce	Pound	Troy Ounce	Penny Weight
1 g	1	5	0.03527	0.00220	0.03215	0.64301
1 ct	0.2	1	0.00705	0.00044	0.00643	0.12860
1 oz	28.34952	141.74762	1	0.06250	0.91146	18.22917
1 lb	453.59237	2267.96185	16	1	14.58333	291.66667
1 ozt	31.10348	155.51738	1.09714	0.06857	1	20
1 dwt	1.55517	7.77587	0.05486	0.00343	0.05	1
1 GN	0.06580	0.32399	0.00229	0.00014	0.00208	0.04167
1 tl (HK)	37.429	187.145	1.32027	0.0852	1.20337	24.06741
1 tl (SGP, Mal)	37.79936	188.99682	1.33333	0.08333	1.21528	24.30556
1 tl (Taiwan)	37.5	187.5	1.32277	0.08267	1.20565	24.11306
1 mom	3.75	18.75	0.13228	0.008267	0.12057	2.41131
1 to	11.66380	58.31902	0.41143	0.02571	0.37500	7.5
1 g	15.43236	0.02672	0.02646	0.02667	0.26667	0.08574
1 ct	3.08647	0.00534	0.00529	0.00533	0.05332	0.01715
1 oz	437.5	0.75742	0.75	0.75599	7.55987	2.43056
1 lb	7000	12.11874	12	12.09580	120.95797	38.88889
1 ozt	480	0.83100	0.82286	0.82943	8.29426	2.66667
1 dwt	24	0.04155	0.04114	0.04147	0.041471	0.13333
1 GN	1	0.00173	0.00171	0.00173	0.01728	0.00556
1 tl (HK)	577.61774	1	0.99020	0.99811	9.98107	3.20899
1 tl (SGP, Mal)	583.33333	1.00990	1	1.00798	10.07983	3.24074
1 tl (Taiwan)	578.71344	1.00190	0.99208	1	10	3.21507
1 mom	57.87134	0.10019	0.09921	0.1	1	0.32151
1 to	180	0.31162	0.30857	0.31103	3.11035	1

Table 6-2. Unit Conversion Table

6.3 NTEP Sealing and Operation

The balance is sealed by threading a wire through two tabs on the bottom front of the scale (see below-right image). One tab is part of the top half of the enclosure and the other is part of the bottom half. There is also a flat plastic plug that covers a hole on the bottom front of the balance which is sealed with a tamper-evident seal. If the plug is removed, a small switch can be accessed to toggle between NTEP and non-NTEP modes.

When in NTEP mode, an outline of the least significant digit displays on the display as shown in the image below with digit 3. NTEP mode does not allow access to the calibration mode.



Figure 6-1. NTEP Mode Display

Depending on capacity, there are two ways to seal the TP Series.

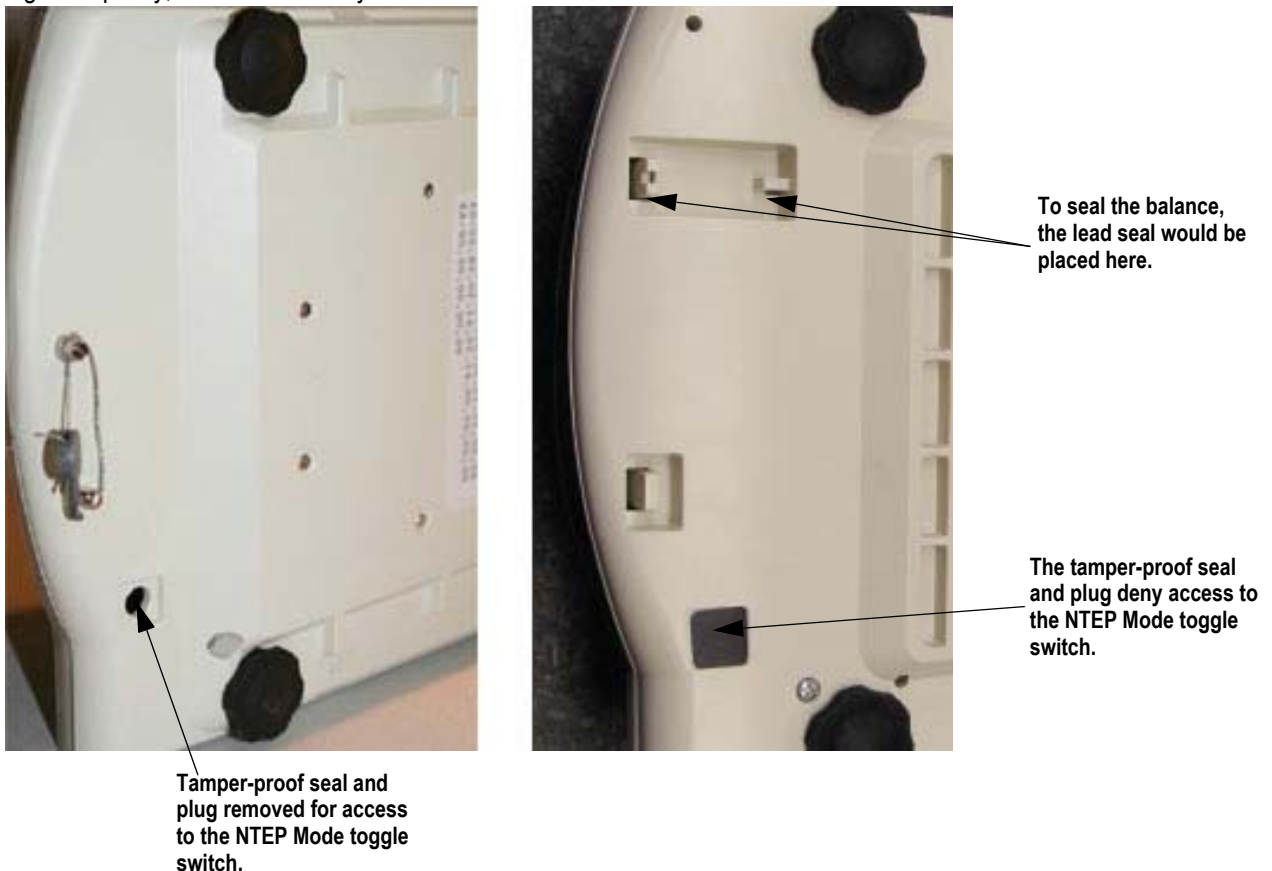

Figure 6-2. Sealing the Balance



© Rice Lake Weighing Systems Specifications subject to change without notice.
Rice Lake Weighing Systems is an ISO 9001 registered company.

230 W. Coleman St. • Rice Lake, WI 54868 • USA
U.S. 800-472-6703 • Canada/Mexico 800-321-6703 • International 715-234-9171 • Europe +31 (0)26 472 1319