

Rice Lake Mechanical Physician Scale (w/ hand post)

Model RL-MPS-30

Operation Instructions



RICE LAKE[®]
WEIGHING SYSTEMS
To be the best by every measure[®]

Contents

- 1.0 Introduction..... 1**
- 2.0 Installation Instructions..... 2**
 - 2.1 Pillar Installation 2
 - 2.2 Steelyard Rod Connection 4
 - 2.3 Height Rod Installation 5
 - 2.4 Wheel Installation 6
- 3.0 Hand Post Installation..... 7**
- 4.0 Zero Adjustment..... 8**
- 5.0 Weighing a Patient 9**
- 6.0 Troubleshooting 9**
- 7.0 Specifications 9**

 *Technical training seminars are available through Rice Lake Weighing Systems. Course descriptions and dates can be viewed at www.ricelake.com or obtained by calling 715-234-9171 and asking for the training department*



Rice Lake continually offers web-based video training on a growing selection of product-related topics at no cost. Visit www.ricelake.com/webinars.

1.0 Introduction

The Rice Lake Mechanical Physician Scale is ideal for height and weight measurement. The scale is durable, having a slip resistant plastic cover, a retractable aluminum height rod, a hand post, and rear wheels. These installation and operating instructions will guide the user through basic instructions on pillar assembly, wheel installation, pillar height rod installation, hand post installation, and the zero adjustment of the scale.

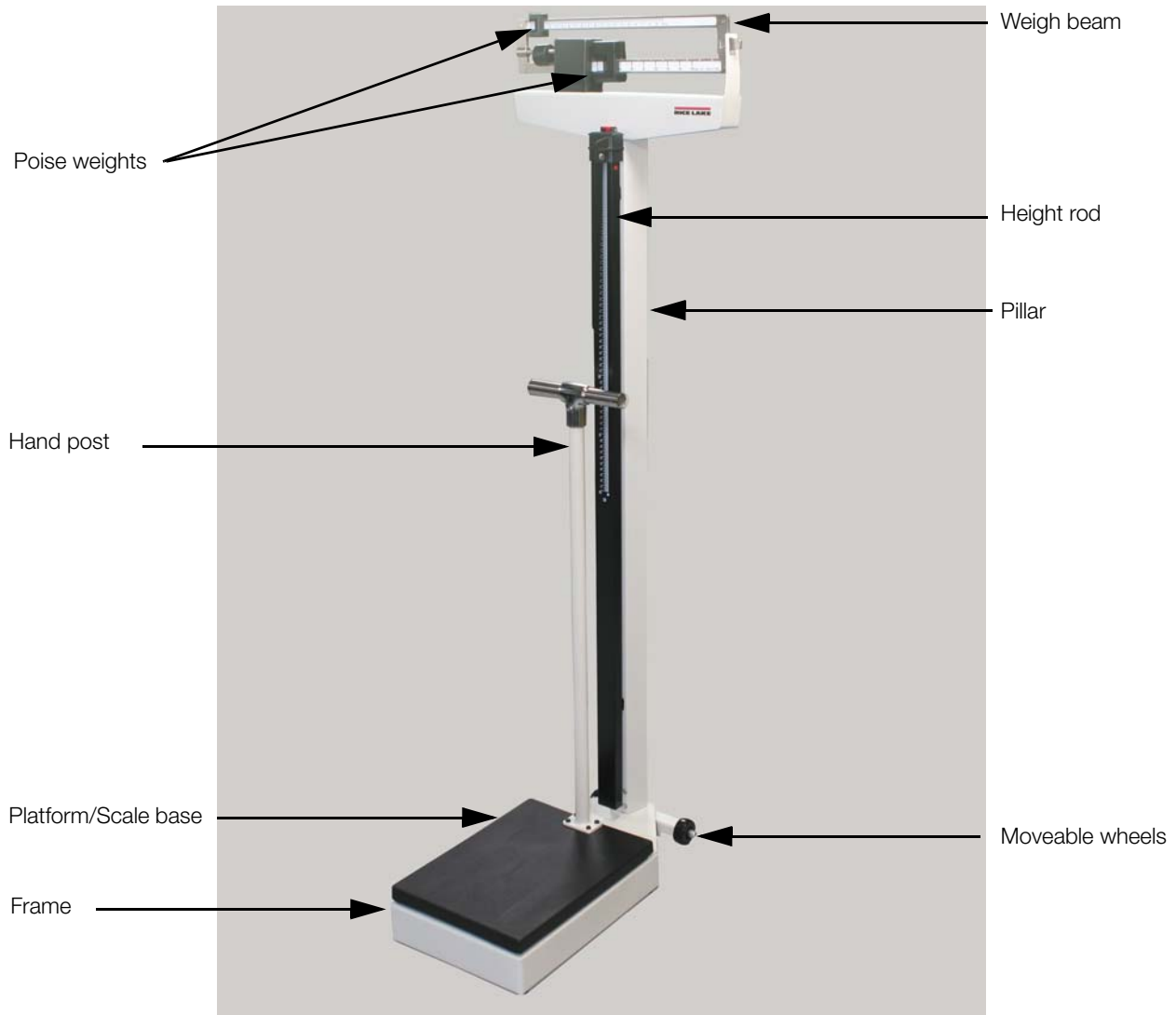

Figure 1-1. Mechanical Physician Scale Parts Breakdown



Internet

This manual can be viewed and downloaded from the Rice Lake Weighing Systems web site at www.ricelake.com/health. Rice Lake Weighing Systems is an ISO 9001 registered company.

2.0 Installation Instructions

You will receive your Mechanical Physician Scale partially assembled. Those items that need additional assembly are:

- Pillar assembly
- Steelyard rod connection
- Height rod installation
- Wheel installation
- Hand post installation

Remove all components from the shipping box (shown in Figure 2-1) and lay out in a convenient place.

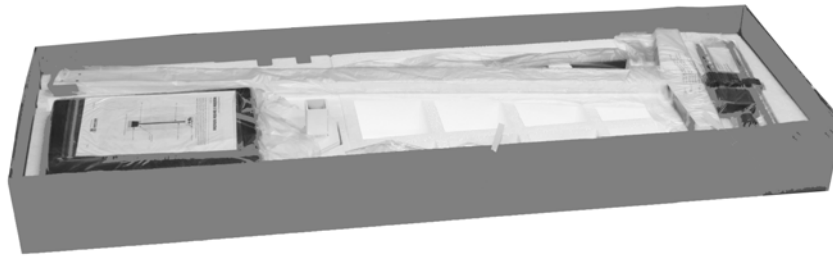

Figure 2-1. Box Contents

2.1 Pillar Installation

Prior to assembly, you'll need the following tools to finish assembling the Mechanical Physician Scale.

- Multi-purpose tool (included)
- Wrench (included)

The pillar comes separate from the scale base and must be attached prior to use. Use the following steps to attach the pillar to the scale base.

1. Set the scale base on a table or other convenient place.
2. Remove the twisty ties off the scale base as shown on the left hand side of Figure 2-2. Remove the cable tie that holds the steelyard rod from shifting during transit (shown on right hand side of Figure 2-2).

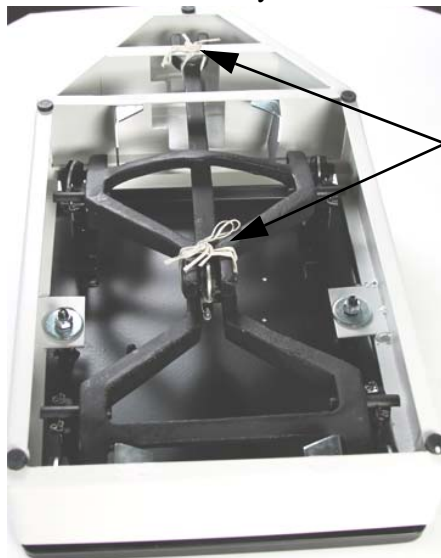

Remove twisty ties from scale parts

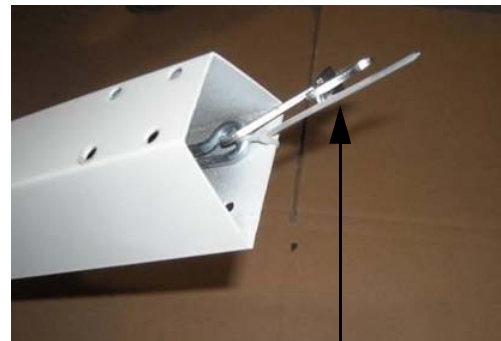

Remove cable tie from steelyard rod

Figure 2-2. Remove Twisty Ties and Cable Ties

3. Insert the pillar into the scale base assembly ensuring that the RLWS logo located on the weight beam faces the scale base.



Figure 2-3. Attach the Pillar to the Scale Base

4. Using the wrench provided, insert and tighten the eight bolts and washers to secure the pillar to scale base.



Figure 2-4. Attach Eight Bolts and Washers to Secure the Pillar to the Scale Base

2.2 Steelyard Rod Connection

The steelyard rod is located inside the scale pillar. Once the pillar is attached to the scale base, the steelyard rod must be attached to the bottom of the scale.

1. Lay the scale pillar on a table so that the scale platform hangs over the edge of the table and allows you to access the bottom of the scale.

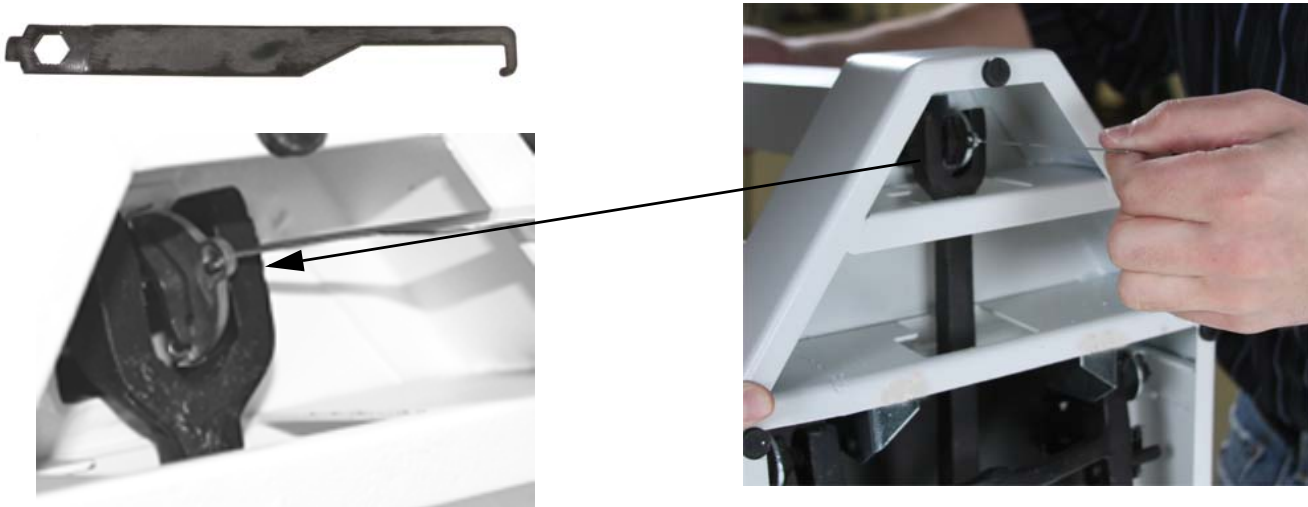

Figure 2-5. Connecting the Steelyard Rod to the Scale Base

2. Insert the hook part of the multi-purpose tool (included and shown above) to the small hole in the bottom of the steelyard rod, and pull the hook of the steelyard rod with the hook of the multi-purpose tool to connect it to the scale base lever as shown in Figure 2-5, then push the scale base lever towards the pillar head, and hook the bearing of the steelyard rod on the pivot of the long lever.



Note

Visually ensure that the force lever assembly linkage is centered and properly aligned. Occasionally during shipping, alignment will become skewed. The linkage must be free floating in order for the scale to weigh properly. The linkage can be seen by looking up underneath the top weigh beam if the scale is slightly tipped to one side.

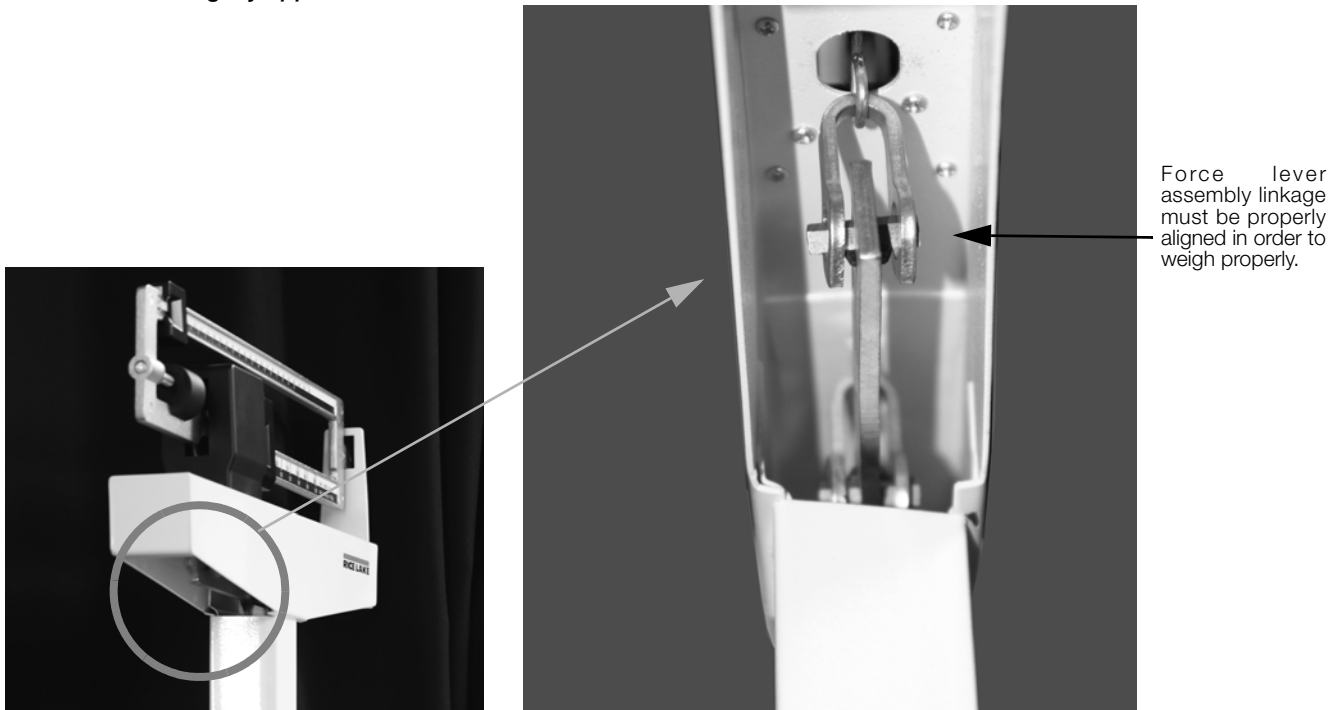

Figure 2-6. View Looking up at Linkage up Underneath the Top Weigh Beam

3. Place the scale gently back on the floor.

2.3 Height Rod Installation

The Mechanical Physician Scale comes with a height rod. Use the following steps to install the height rod.

1. Insert the back side slotted holes of the height rod into the two bolts on the front side of the pillar as shown in Figure 2-7. One is located at the top of the pillar and the other towards the bottom of the pillar.

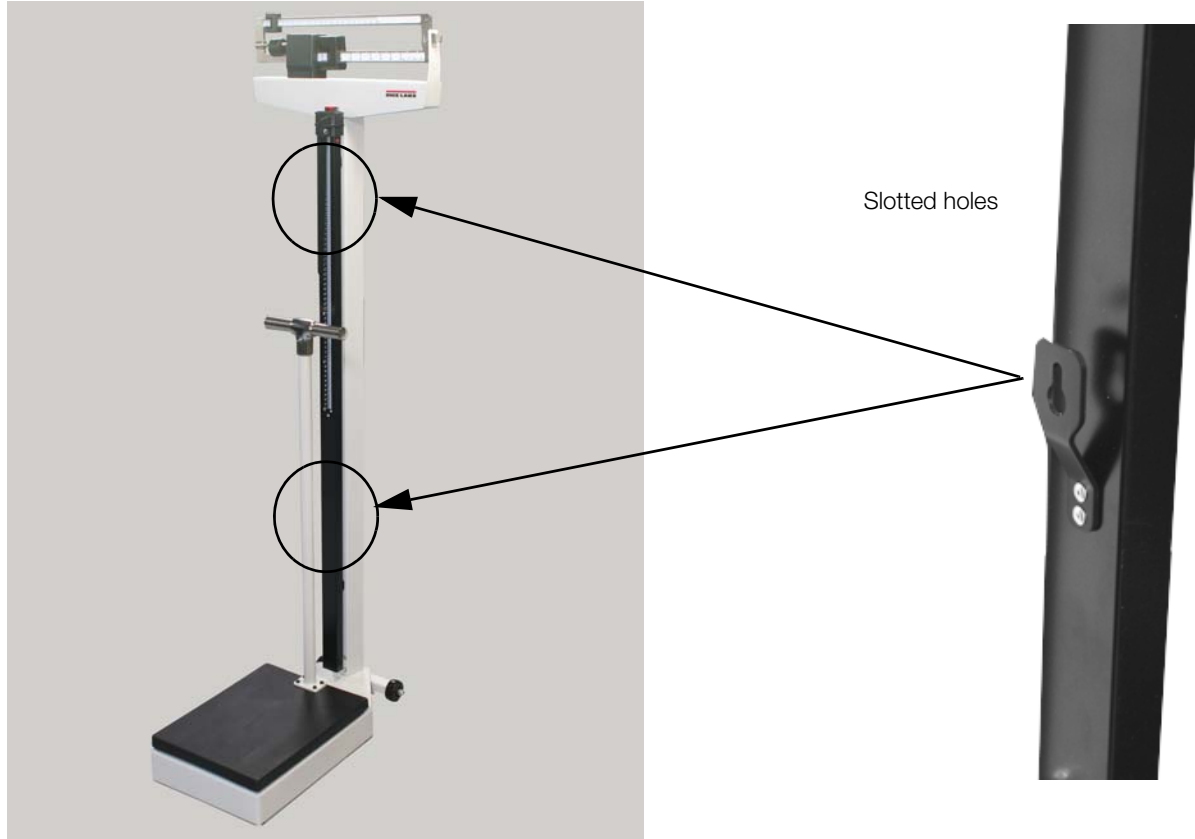

Figure 2-7. Attach the Slotted Screw Location onto the Pillar Bolt Location

2. Use the enclosed wrench to tighten the two stainless steel hex-head screws, but ensure not to over tighten.
3. To raise or lower the height rod, press the red button at the top of the height rod and raise up or down.

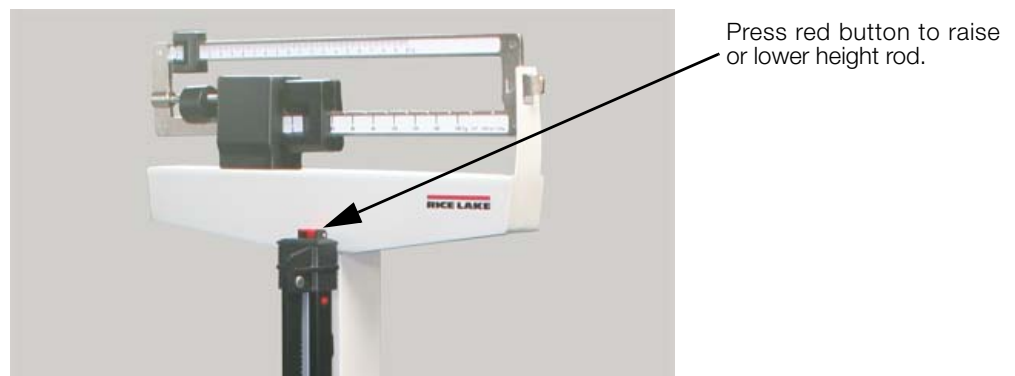

Figure 2-8. Height Rod Button

2.4 Wheel Installation

The Mechanical Physician Scale comes with sturdy wheels for easy portability. To install the wheels onto the scale, use the following instructions.



Note *Mounting the wheels upside down can create scale errors.*

1. Align the angle iron of the wheel base to the scale platform as shown in Figure 2-9.

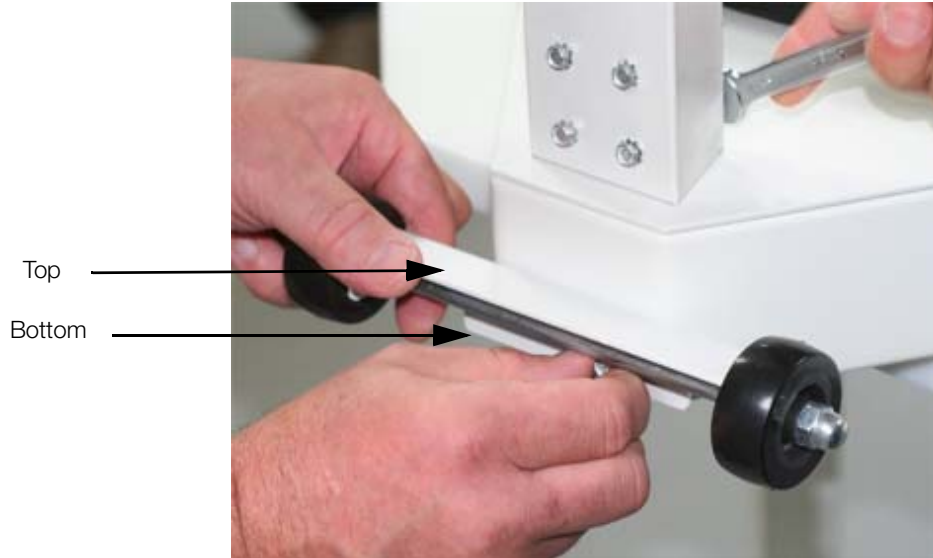

Figure 2-9. Attach the Scale Wheels onto the Scale Base

2. Use the screws and washers that are included with the scale to fix the wheel to the platform, adjusting the angle iron at a level position, then tighten screws.
3. When moving the scale, hold the two side faces of the pillar to keep the front side of the platform away from the ground.



Figure 2-10. Wheels Offer Easy Portability

3.0 Hand Post Installation

The Rice Lake Mechanical Physician scale comes with a hand post to add in balancing a patient while on the scale. Use the following steps to install the hand post to the scale.

1. Unscrew the four hex head screws from the scale base and set the screws and washers aside.



Figure 3-1. Unscrew Hex Head Screws From Scale Platform

2. Position the hand post over the screw holes on the scale platform making sure that the washer is set between the hand post base and the screw.



Figure 3-2. Position Hand Post

3. Tighten all four hex head screws with the wrench that has been provided.



Figure 3-3. Tighten Hex Head Screws



Warning *Do not attempt to transport the scale by the hand post. Serious injury could occur to the scale and to the operator.*

4.0 Zero Adjustment

To ensure accurate weighments, a zero adjustment should be done to the scale upon arrival and setup. To perform a zero adjustment, carry out the following steps.

1. Ensure the scale is sitting on a level surface.
2. Make sure that the poise weights are pushed all the way to the left hand side (at zero) making sure that the large poise is firmly seated in the notch and the small poise is firmly against the shoulder of the beam.
3. Check the eye loop area of the scale to ensure that the scale pointer is equally balanced between the eye loop area.

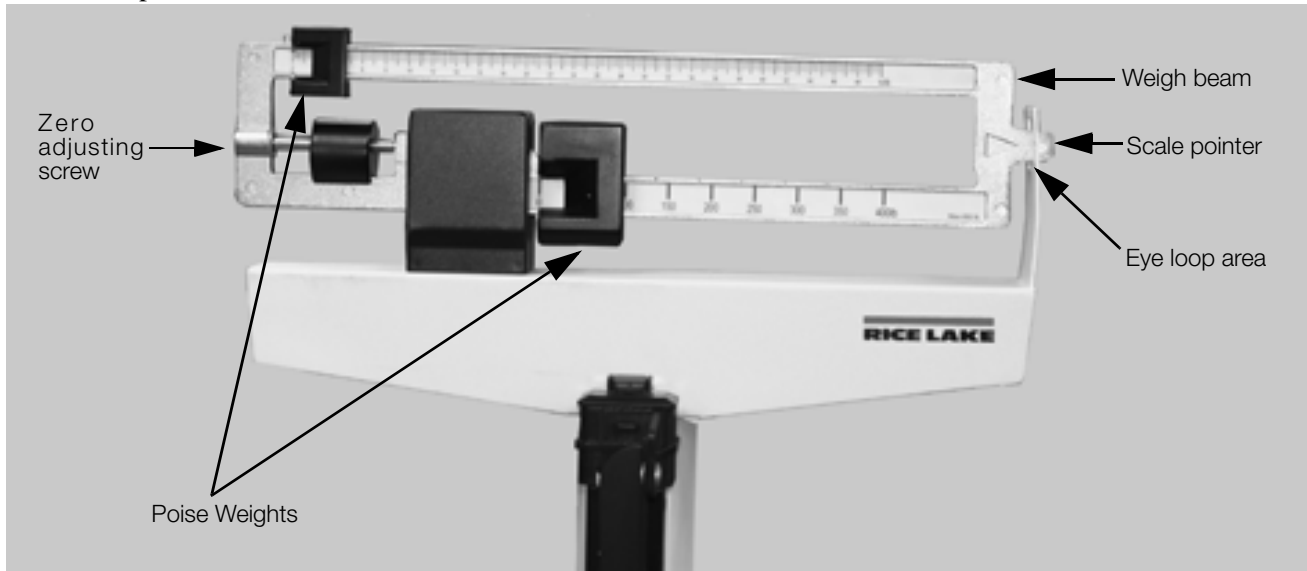

Figure 4-1. Eye Loop Area and Zero Adjusting Screw Location

4. If the scale is not balancing properly, then the small zero balance weight must be adjusted. Turn the zero adjusting screw (shown in Figure 4-1) using a flat head screwdriver. By adjusting the screw, the zero balance weight will move accordingly.



Figure 4-2. Zero Adjusting Screw Location

5.0 Weighing a Patient

To weigh a patient, have the patient step onto the scale platform and slide the larger poise (shown on bottom) to the approximate target weight. Next move the smaller poise on top until the weigh beam balances and the scale pointer is centered within the eye loop area as shown in Figure 4-1.

6.0 Troubleshooting

For the most accurate weight, always use the scale on a hard, level surface and stand in the center of the platform with the weight distributed as evenly as possible. If an error occurs or seems excessive, check the following:

Problem	Possible Fix
Zero balance of beam	The weigh beam must be balanced so the pointer comes to a rest in the center of the eye loop (shown in Figure 3-1) when both poise weights are set at zero (see Figure 1-1 for poise weight location). Adjust the balance by turning the zero adjusting screw at the left end of the weigh beam (see Figure 4-1).
Beam does not move freely	Check if the beam pointer is touching the side of the eye loop in its range of travel. Visually ensure that the linkage is centered and properly aligned. Occasionally during shipping, the alignment will become skewed. The linkage must be free floating in order for the scale to weigh properly. The linkage can be seen by looking up underneath the top weigh beam if the scale is slightly tipped to one side.
Platform rocks excessively	When you push down on any corner of the platform, you should not feel any significant rocking. Ensure scale is setting on a level surface.
Beam does not move at all during a weighment	This can be caused by the poise weights being set to a higher weight than the person's actual weight. Reset the weights to a lower weight. Also check to see that the steelyard rod is properly connected and aligned (see Figure 2-6).
Scale is out of calibration	Recalibrate the scale by placing a known weight on the scale and moving the zero adjusting screw to bring the scale back to zero.

Table 6-1. Troubleshooting Guide

7.0 Specifications

	RL-MPS-30
Maximum Capacity	180 kg
Graduation	0.1 kg
Height Rod Range	60-212 cm
Min. Value of Height per Division	0.1 cm
Platform Size	374.65 x 273.05 mm
Hand Post Height	80 cm

Table 7-1. Model Specifications

For More Information

Web Site

- <http://www.ricelake.com/health>

Contact Information

Hours of Operation

Knowledgeable customer service representatives are available 6:30 a.m. - 6:30 p.m. Monday through Friday and 8 a.m. to 12 noon on Saturday. (CST)

Telephone

- Sales/Technical Support 800-472-6703
- Canadian and Mexican Customers 800-321-6703
- International 715-234-9171

Fax

- Fax Number 715-234-6967

Email

- US sales and product information at prodinfo@ricelake.com
- International (non-US) sales and product information at intlsales@ricelake.com

Mailing Address

Rice Lake Weighing Systems

230 West Coleman Street

Rice Lake, WI 54868 USA

Mechanical Physician Scale Limited Warranty

Rice Lake Weighing Systems warrants that all RLWS equipment and systems properly installed by a Distributor or Original Equipment Manufacturer (OEM) will operate per written specifications as confirmed by the Distributor/OEM and accepted by RLWS. All systems and components are warranted against defects in materials and workmanship for two years.

RLWS warrants that the equipment sold hereunder will conform to the current written specifications authorized by RLWS. RLWS warrants the equipment against faulty workmanship and defective materials. If any equipment fails to conform to these warranties, RLWS will, at its option, repair or replace such goods returned within the warranty period subject to the following conditions:

- Upon discovery by Buyer of such nonconformity, RLWS will be given prompt written notice with a detailed explanation of the alleged deficiencies.
- Examination of such equipment by RLWS confirms that the nonconformity actually exists, and was not RLWS shall be the sole judge of all alleged non-conformities.
- Such equipment has not been modified, altered, or changed by any person other than RLWS or its duly authorized repair agents.
- RLWS will have a reasonable time to repair or replace the defective equipment. Buyer is responsible for shipping charges both ways.
- In no event will RLWS be responsible for travel time or on-location repairs, including assembly or disassembly of equipment, nor will RLWS be liable for the cost of any repairs made by others.

THESE WARRANTIES EXCLUDE ALL OTHER WARRANTIES, EXPRESSED OR IMPLIED, INCLUDING WITHOUT LIMITATION WARRANTIES OF MERCHANTABILITY OR FITNESS FOR A PARTICULAR PURPOSE. NEITHER RLWS NOR DISTRIBUTOR WILL, IN ANY EVENT, BE LIABLE FOR INCIDENTAL OR CONSEQUENTIAL DAMAGES.

RLWS AND BUYER AGREE THAT RLWS'S SOLE AND EXCLUSIVE LIABILITY HEREUNDER IS LIMITED TO REPAIR OR REPLACEMENT OF SUCH GOODS. IN ACCEPTING THIS WARRANTY, THE BUYER WAIVES ANY AND ALL OTHER CLAIMS TO WARRANTY.

SHOULD THE SELLER BE OTHER THAN RLWS, THE BUYER AGREES TO LOOK ONLY TO THE SELLER FOR WARRANTY CLAIMS.

NO TERMS, CONDITIONS, UNDERSTANDING, OR AGREEMENTS PURPORTING TO MODIFY THE TERMS OF THIS WARRANTY SHALL HAVE ANY LEGAL EFFECT UNLESS MADE IN WRITING AND SIGNED BY A CORPORATE OFFICER OF RLWS AND THE BUYER.

© 2012 Rice Lake Weighing Systems, Inc. Rice Lake, WI USA. All Rights Reserved.

RICE LAKE WEIGHING SYSTEMS • 230 WEST COLEMAN STREET • RICE LAKE, WISCONSIN 54868 • USA



230 W. Coleman St. • Rice Lake, WI 54868 • USA
U.S. 800-472-6703 • Canada/Mexico 800-321-6703
International 715-234-9171

www.ricelake.com
m.ricelake.com

© 2012 Rice Lake Weighing Systems

PN 132702 11/12