

# RoughDeck® AX-1

---

*Heavy Capacity  
Axle Scale System*

## Installation Manual



An ISO 9001 registered company  
© Rice Lake Weighing Systems. All rights reserved.

Rice Lake Weighing Systems® is a registered trademark of  
Rice Lake Weighing Systems.

All other brand or product names within this publication are trademarks or  
registered trademarks of their respective companies.

All information contained within this publication is, to the best of our knowledge, complete  
and accurate at the time of publication. Rice Lake Weighing Systems reserves the right to  
make changes to the technology, features, specifications and design of the equipment  
without notice.

The most current version of this publication, software, firmware and all other product  
updates can be found on our website:

**[www.ricelake.com](http://www.ricelake.com)**

- 1.0 Introduction..... 1**
  - 1.1 Safety..... 1
  - 1.2 Operating Requirements..... 2
- 2.0 Installation ..... 3**
  - 2.1 Installation Overview..... 3
  - 2.2 Site Preparation..... 3
  - 2.3 Unpacking..... 4
  - 2.4 Setup and Assembly..... 5
    - 2.4.1 Positioning the Scale..... 5
    - 2.4.2 Installing Access Ramps..... 5
  - 2.5 Junction Box..... 6
  - 2.6 Electrical Ground Connections..... 7
- 3.0 Adjustments and Calibration ..... 8**
  - 3.1 Mechanical Adjustments..... 8
  - 3.2 Corner Correction..... 8
- 4.0 Service Information ..... 10**
  - 4.1 Troubleshooting Guide..... 10
  - 4.2 Periodic Maintenance..... 10
  - 4.3 Load Cell Replacement..... 11
  - 4.4 Load Cell Wiring to Junction Box..... 12
  - 4.5 Dimension Drawings..... 13
    - 4.5.1 RoughDeck AX-1 Scale..... 13
    - 4.5.2 RoughDeck AX-1 Scale with Ramps..... 14
    - 4.5.3 Frame..... 15
    - 4.5.4 RoughDeck AX-1 Scale and Frame with Ramps..... 16



Technical training seminars are available through Rice Lake Weighing Systems. Course descriptions and dates can be viewed at [www.ricelake.com/training](http://www.ricelake.com/training) or obtained by calling 715-234-9171 and asking for the training department.

© Rice Lake Weighing Systems. All rights reserved. Printed in the United States of America.  
Specifications subject to change without notice.  
Rice Lake Weighing Systems is an ISO 9001 registered company.  
20 June 2016



*Rice Lake continually offers web-based video training on a growing selection of product-related topics at no cost. Visit [www.ricelake.com/webinars](http://www.ricelake.com/webinars)*

# 1.0 Introduction

Rice Lake's *RoughDeck*® AX-1 provides accurate vehicle axle weighing for non-NTEP vehicle applications. The *RoughDeck* AX-1 is equipped with a top and bottom steel deck, ensuring durable performance under the toughest conditions. With a 50,000 pound capacity, the *RoughDeck* AX-1 is the ideal solution for on-site vehicle weighing. The *RoughDeck* AX-1 has several options available for purchase.

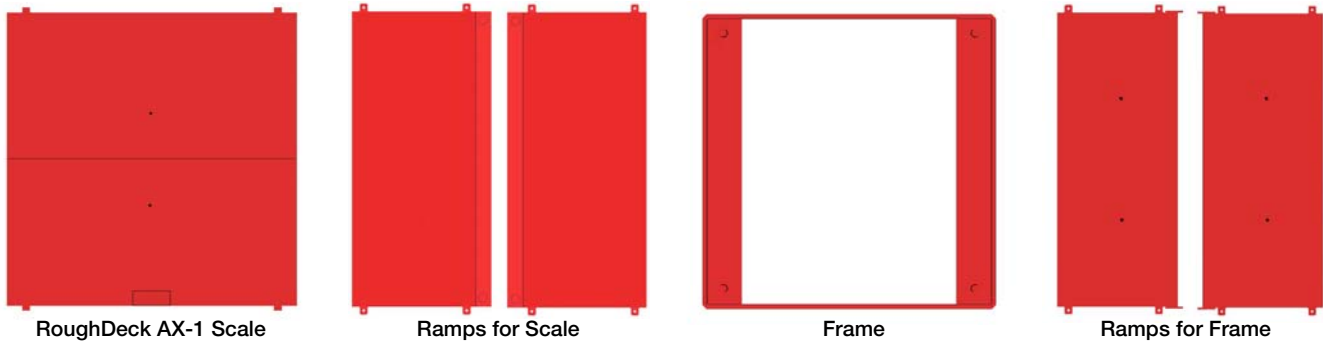

Figure 1-1. *RoughDeck* AX-1 Options

## 1.1 Safety

### Safety Symbol Definitions



**DANGER** Indicates an imminently hazardous situation that, if not avoided, will result in death or serious injury.



**WARNING** Indicates a potentially hazardous situation that, if not avoided could result in serious injury or death, and includes hazards that are exposed when guards are removed.



**CAUTION** Indicates a potentially hazardous situation that, if not avoided may result in minor or moderate injury.



**Important** Indicates information about procedures that, if not observed, could result in damage to equipment or corruption to and loss of data.

### General Safety



Do not operate or work on this equipment unless you have read and understand the instructions and warnings in this manual. Failure to follow the instructions or heed the warnings could result in injury or death. Contact any Rice Lake Weighing Systems dealer for replacement manuals. Proper care is your responsibility.



**Failure to heed may result in serious injury or death.**

Do not allow minors (children) or inexperienced persons to operate this unit.

Do not operate without all shields and guards in place.

Do not jump on the scale.

Do not use for purposes other than weight taking.

Do not place fingers into slots or possible pinch points.

Do not use any load bearing component that is worn beyond 5% of the original dimension.

Do not use this product if any of the components are cracked.

Do not exceed the rated load limit of the unit.

Do not make alterations or modifications to the unit.

Do not remove or obscure warning labels.

Do not use near water.

Before opening the unit, ensure the power cord is disconnected from the outlet.

Always strive for a single-point grounding system to avoid ground-loop current flows which could corrupt the scale.

## 1.2 Operating Requirements

The following are basic operating requirements for the *RoughDeck AX-1*.

### **Electrical Grounding**

For systems where the scale is connected to a 115 VAC circuit, the indicator must be directly connected to an earth ground with a ground interface cable of no more than  $3\Omega$  resistance throughout its length.

### **Load Cell Excitation**

Rated Excitation: 10 VDC

Maximum Excitation: 15 VDC

### **Grade Level Requirements**

The supporting surface for the four feet of the scale must be level within  $\frac{1}{4}$  " of horizontal.

### **End Load Capacity**

80% full scale at 50,000 lb

## 2.0 Installation

---

### 2.1 Installation Overview

Standard installation of the *RoughDeck AX-1* consists of the following steps:

1. Select a site with a level compacted surface.
2. Unpack scale equipment.
3. Setup and assemble the equipment.
4. Connect cable to junction box and indicator.
5. Calibrate the unit.

### 2.2 Site Preparation

Careful consideration must be taken when preparing a site to install the *RoughDeck AX-1*.



**Note** *The scale must be placed on a flat, level and hard surface equal to or better than 3000 psi concrete. In addition, the concrete slab must be able to withstand the dead weight and rated live loading of the scale without cracking or flexing under load.*

- Never load the scale beyond capacity, even momentarily.
- Do not select a site where overweight loads would have to swerve to avoid crossing the platform.
- Avoid areas where the scale could receive damaging side impacts or shock damage.
- Avoid areas where water may damage the scale (which is not meant for a washdown environment).
- The site should have a level grade for the approach and exit. In operation, the scale must be level within 1/4".
- If the *RoughDeck AX-1* is not on level ground, errors can occur due to weight being transferred. Additionally, friction in the vehicle's suspension system can draw the weight off the axle being weighed — especially if the brakes are applied.
- Ensure the scale is clear of rocks and debris.
- All cables must be protected against crushing, cutting and moisture. If the chosen site has such potential dangers, some method of protection, such as running the cable in conduit, is necessary.

## 2.3 Unpacking

Remove all packing material and inspect for visible damage caused during shipping. If any parts were damaged in shipping, notify Rice Lake Weighing Systems and the shipper immediately.

If the scale was purchased with a frame, it is necessary to remove the shipping tabs. After removing the shipping tabs, lift the scale out of the frame using the provided eye bolts (Figure 2-2 and Section 2.4 on page 5) and remove the shipping blocks located under the scale (Figure 2-1). Lower the scale back down into frame. Adjust the scale so it is flush with the frame.



**Note** Retain the shipping tabs for future use.

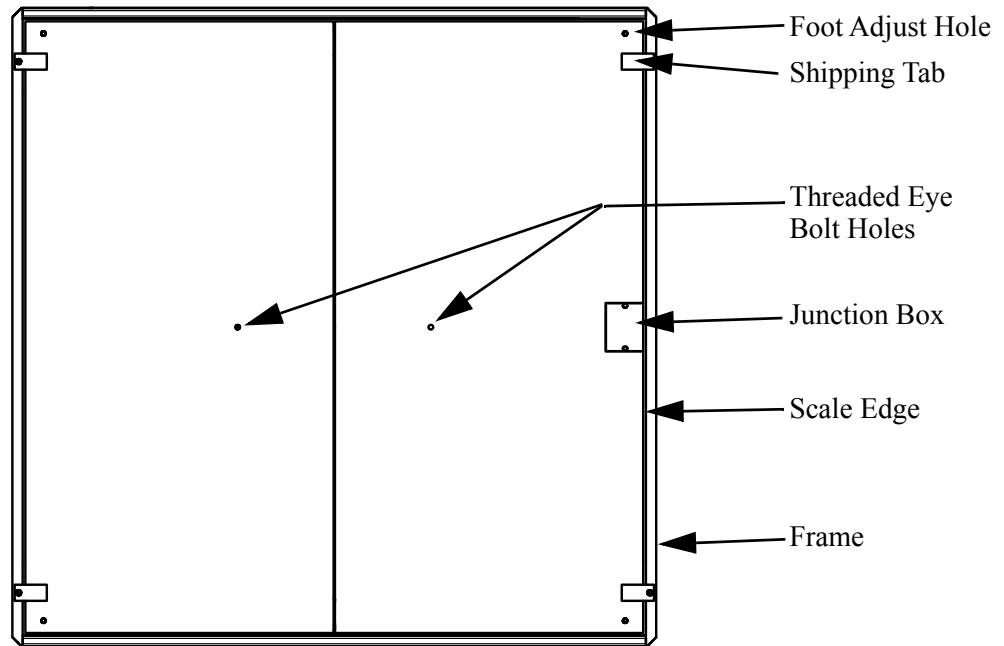

Figure 2-1. RoughDeck AX-1 with Frame

All *RoughDeck AX-1* models have threaded holes in the deck to allow the installation of eye bolts (included) for use when lifting the scale with chains or a spreader bar.



**Important** Lift the scale only with a properly designed spreader bar as shown in Figure 2-2. Lifting force must be vertical to avoid bending the eye bolts.



**WARNING** Eye bolts must be inserted into the threaded eye bolt holes on the top of the scale. Lifting must be done with the top plate facing up and the eye bolts securely attached through the nuts welded to the bottom side of the top plate.

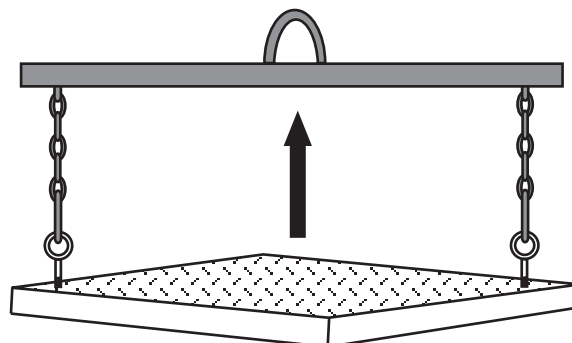

Figure 2-2. Proper Lifting Technique



## 2.4 Setup and Assembly

The *RoughDeck AX-1* can be set up with or without a frame on top of a level concrete pad with approach ramps installed.

Once the site has been properly prepared, lift the weighbridge into position ensuring that it corresponds to the wheel configurations and dimensions of the vehicle being weighed.

### 2.4.1 Positioning the Scale

1. Install provided eye bolts securely through the nuts welded to the bottom side of the top plate.
2. Attach chains to the eye bolts to lift and position the scale. See Figure 2-2.



**WARNING** Eye bolts must be inserted into the threaded eye bolt holes on the top of the scale. Lifting must occur with the top plate facing up and the eye bolts securely attached through the nuts welded to the bottom side of the top plate.

### 2.4.2 Installing Access Ramps

Access ramps are designed to fit securely with the *RoughDeck AX-1*.

#### Access Ramps with Scale (No Frame)

Once the *RoughDeck AX-1* is set in place, ramps can be positioned with the scale.

1. Lift the ramps using the provided eye bolts and set ramps in place. Orient the ramps along the longitudinal axis of the load cells. See Figure 2-3.



**WARNING** Eye bolts must be inserted into the threaded eye bolt holes on the top of the ramp. Lifting must occur with the top plate facing up and the eye bolts securely attached through the nuts welded to the bottom side of the top plate.

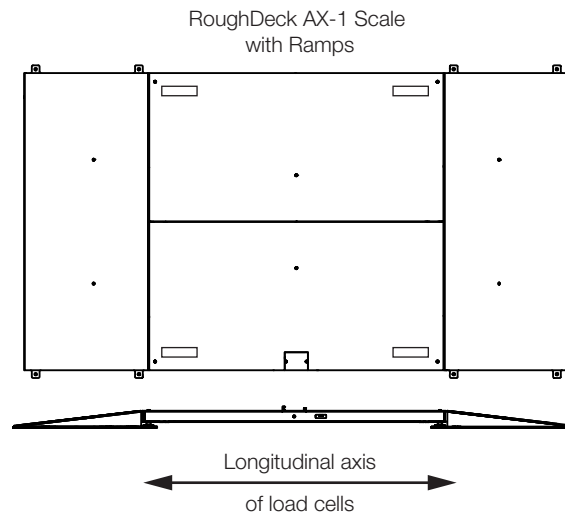

Figure 2-3. Align Ramps with Load Cells

2. Align the scale's feet with the foot holes of the ramp.

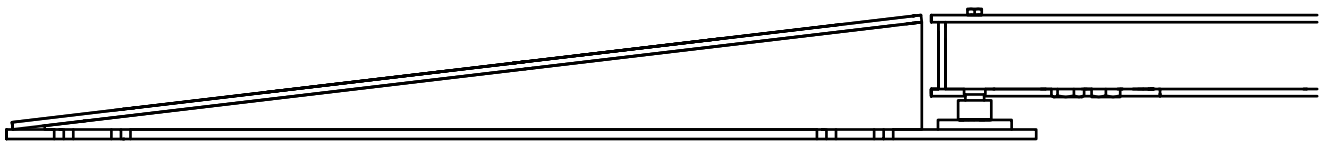

Figure 2-4. Align Scale's Feet with Foot Holes in Ramp

3. Secure the ramp in position by utilizing the four anchor tabs on the ramp.

## Access Ramps with Scale and Frame

Once the *RoughDeck AX-1* with frame is set in place, the ramps can be attached to the scale and frame.

1. Lift the ramps using the provided eye bolts and set the ramps in place. Orient the ramps along the longitudinal axis of the load cells. See Figure 2-5.



Eye bolts must be inserted into the threaded eye bolt holes on the top of the ramp. Lifting must occur with the top plate facing up and the eye bolts securely attached through the nuts welded to the bottom side of the top plate.

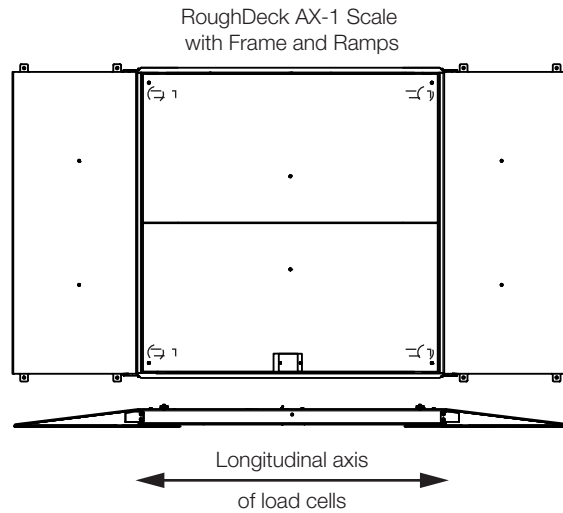

Figure 2-5. Align Ramps with Load Cells

2. Position the ramp so the holes of the mounting tabs align with the holes on the frame. Bolt in place.

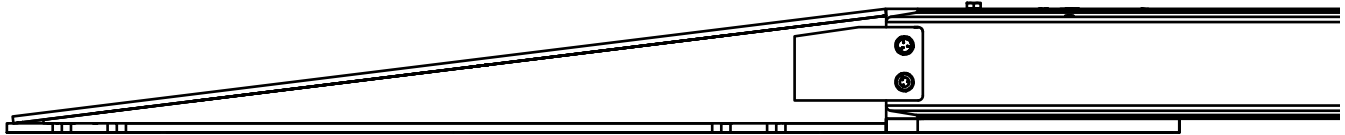

Figure 2-6. Align Access Ramp with Frame

3. Secure the ramp in position by utilizing the four anchor tabs on the ramp.

## 2.5 Junction Box

The junction box is located inside the of the *RoughDeck AX-1* as shown in Figure 2-7. The junction box comes pre-installed and pre-wired from the factory. To access the junction box area, remove the two bolts using a 9/16" socket and remove the top plate.

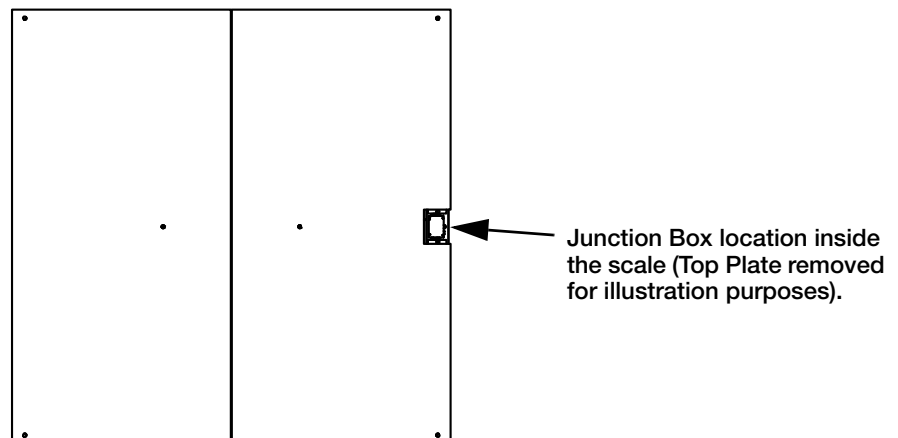

Figure 2-7. Junction Box Position

## 2.6 Electrical Ground Connections



**Important** *Improper grounding systems on axle scales can cause corrupted data from ground-loop current flows and costly lightning damage to electronics.*

Always strive for a single-point grounding system. Do not drive ground rods at the scale location to establish separate earth grounds for the scale. These separate earth grounds do not share the same zero reference as the existing earth ground for the AC power system. This difference in electrical potential invites ground-loop current flow between the separate grounds, often corrupting serial data like RS-232 which depends on a stable zero reference.

In addition, a separate earth ground system at the scale can actually invite lightning or power surge damage:

- A minor power line surge in the scale house electrical supply should immediately be shunted to ground. If a separate ground system exists at the scale with a lower potential than the main ground, the surge may travel out to the scale ground rod, damaging load cells on its way.
- A nearby lightning ground strike may instantly raise the zero potential of a ground rod at the scale location, while leaving the scale house ground rod unaffected. The lightning surge then takes the easiest path to the lower-potential ground—through the scale wiring and back to the scale house ground, possibly damaging the indicator on its way.

Therefore, the best grounding system for the scale is the same grounding system used for the incoming AC power system. The 120 VAC power source used to power the indicator is connected to an existing earth ground rod system at the scale house or other building where the indicator is located. This should consist of a double ground rod system of two 5/8" x 8' copper rods driven 8' deep at the service entrance where the local utility company brings their lines into the building.

The local utility company can test the resistance of the existing ground rods with a clamp-on megohmmeter that measures zero resistance. A reading of 3 3/4 or less is acceptable as a ground. If the test determines that the grounding system is inadequate, the utility company can suggest methods to improve the system. It is crucial that the scale owner authorize and make the recommended improvements to ensure an adequate electrical ground. Do not connect the scale to the AC power supply until the grounding system is adequate.

Be certain each load cell grounding strap is securely connected to the top plate and bottom plate of each load cell mount. Some models have ground straps included to install between modules if more than one segment is used. These inter-module straps ensure that the entire scale is connected to the same single point ground. There should be metal-to-metal contact with no presence of paint or grout. This strap is designed to channel power surges on the deck around—rather than through—the load cell to ground. These, and all, ground connections must be torqued to a specified value and re-torqued at regular service intervals. A thick coating of anti-oxidant grease should be maintained on all ground connections to prevent corrosion.

A separate grounding system conductor must extend uninterrupted from the main service panel ground to the scale to protect load cells and scale wiring from lightning and other transient damage. This ground wire conductor must be an unsheathed #10 copper wire or larger. Run the bare ground wire conductor intact from the AC power ground rod to the scale in a separate trench. Bring the wire up from the trench near the junction box and attach it to the ground lug located in the junction box pocket. This grounds the scale frame to the same single-point ground as the AC power for the indicator.

A ground wire is included to attach the junction box ground lug to the ground lug located in the junction box pocket. Grounding of the junction box is essential for operation of the DC transient protection incorporated into the junction box.

# 3.0 Adjustments and Calibration

## 3.1 Mechanical Adjustments

To accommodate minor unevenness, the scale feet can be used to adjust the scale height up or down. Adjust the feet using the top access foot adjust holes until the scale is level.



**CAUTION** When adjusting scale feet, use care to prevent scale foot from bottoming out against the underside of the load cell. Also, the foot stem may be damaged by bending or stripping threads if extended beyond the maximum height adjustment.

When adjustments are complete, recheck level of the deck with a spirit level. The deck must be level within 1/4".

## 3.2 Corner Correction

All assembled *RoughDeck AX-1* scales are delivered with the junction box corner trimmed. Corner trimming is only necessary after replacing a load cell.

Trimming is a process of equalizing the output from multiple individual load cells. If needed, load cell output can be individually trimmed with potentiometers. Whenever a substantial amount of trim (more than 5% of normal output), seems necessary to equalize output check for other possible problems. The best trim is always the least amount of trim. When all errors except cell mismatch and cable extensions or reductions have been corrected, continue with the trimming.

Use the following steps to properly trim the junction box.

1. Make sure jumpers are in place to enable trimming of the cells corresponding to each load cell. See Figure 3-1 for the location of jumpers JP1, JP2, JP3, and JP4.



**Note** Jumpers for unused cells must be removed.

2. Set all potentiometers fully clockwise to give maximum signal output from each cell (See Figure 3-1 for location of potentiometers).

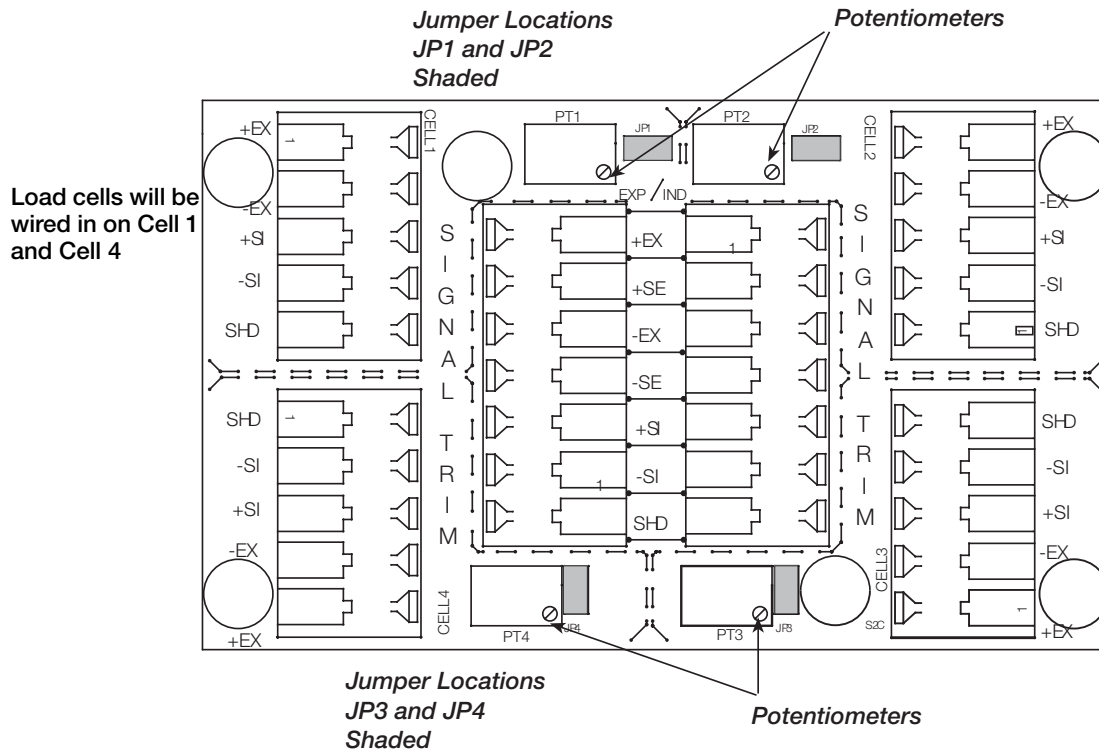

Figure 3-1. Potentiometer Locations

3. Zero the indicator and place calibrated test weights over each load cell, one at a time. The amount of test weight to be used will depend on the configuration. Rice Lake Weighing Systems recommends using 25% of the scale capacity.

4. Record the value displayed on the indicator after each test weight is placed, one at a time, on each end directly over the load cell, without allowing the weight to overhang the sides. Allow the *RoughDeck AX-1* to return to zero each time to check for friction or other mechanical problems. Select the load cell that has the lowest value as the reference point. This cell will not be trimmed and will be the reference load cell.
5. Place the same test load over each cell one at a time. Using the corresponding potentiometer, trim each cell down to equal the reference load cell. As end corrections are somewhat interactive, check all cells again for repeatability. If necessary, repeat steps 4 and 5.



**Note** *Trimming procedures must match in order to proceed to weigh pad/section trimming in Step 11.*

6. Pull excess cable out of the enclosure and tighten the cord grip assemblies with a wrench. To be watertight, each cord grip must be tightened so the rubber sleeve begins to protrude from the hub.
7. Unused hubs must be properly plugged to prevent moisture entry.
8. Remove the desiccant from the plastic bag, and insert the desiccant bag into the junction box before closing. Inspect the desiccant during normal service and change the desiccant as needed.
9. Replace the cover and torque the cover screws in an alternating pattern 15 in-lb to be certain the gasket is compressed equally in all locations.
10. When the home run cable is protected and in its final position, complete connection to the indicator. See the indicator installation manual for wiring information.
11. Perform calibration using 25% of the Rice Lake *RoughDeck AX-1* total capacity, referring to the indicator manual to determine the correct calibration procedure.

## 4.0 Service Information

### 4.1 Troubleshooting Guide

Issue	Cause	Solution
System does not operate - no display	Power disconnected	Check and reconnect
	Indicator fuse blown	Replace fuse. Check for cause
	Interface cable cut or disconnected	Repair
	Signal leads incorrectly installed at indicator	Install using indicator installation manual
Display stays at zero	Indicator faulty	Service indicator
	Load cell connections faulty	Check cable connections in junction box and at indicator
Erratic weights	Vibration near scale	Remove source of vibration or move scale
	Platform not level to within 1/4"	Level scale by adjusting feet or shiming if necessary
	Load cell or cable water damage	Replace
	Debris under load cells or platform	Clean
	Indicator faulty	Use simulator to test indicator for stability. Service indicator
Consistently high or low weights	Indicator not properly adjusted to zero	Zero the indicator according to indicator manual
	Platform binding	Obtain adequate clearance for free platform movement
	Indicator not calibrated	Calibrate according to indicator manual
	Load cells faulty	Test and replace load cells if necessary
	Feet touching deck underside	Adjust feet downward to provide clearance

Table 4-1. Troubleshooting

### 4.2 Periodic Maintenance

The space between the platform side and pit frame, and the surface beneath the platform must be periodically cleaned to prevent debris build up. More frequent cleaning of these areas is necessary with scales mounted in pits.



**Do not attempt to use scales with load cells that are not hermetically sealed in washdown applications. Water damage is a common cause of failure in non-hermetically-sealed load cells. Use care with high pressure steam wash downs for hermetically-sealed load cells. The steam may not damage the load cells, but the elevated temperatures may cause incorrect readings until the unit cools to room temperature.**

### 4.3 Load Cell Replacement

Disconnect the home run cable from the junction box and cut the cable ties. Lift the scale with chains and proper spreader bar and remove feet. Disconnect the defective load cell from the junction box. Pull the load cell and cable out of the scale frame channel. Reverse this procedure for the installation of a new load cell.

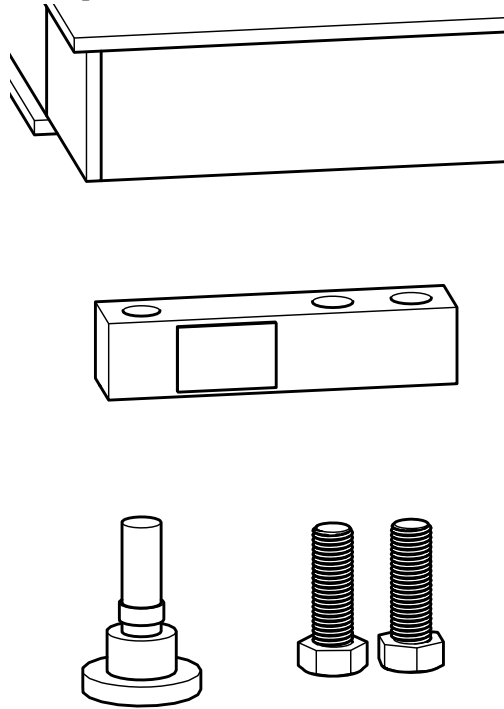

Figure 4-1. Load Cell Assembly

To reset overload stops after load cell installation, place a weight equal to 25% of the load cell capacity on the affected scale corner.

Lay out the four load cells near the corners where they are to be installed. Thread the cable from each load cell through the conduit tubing in the frame and into the junction box according to Table 4-1.

Note that in Figure 4-2 both the scale and the junction box are viewed from the bottom. To verify correct load cell/junction box terminal matching, see the numbers on the terminals inside the junction box and the corner numbering diagram in Figure 4-4.

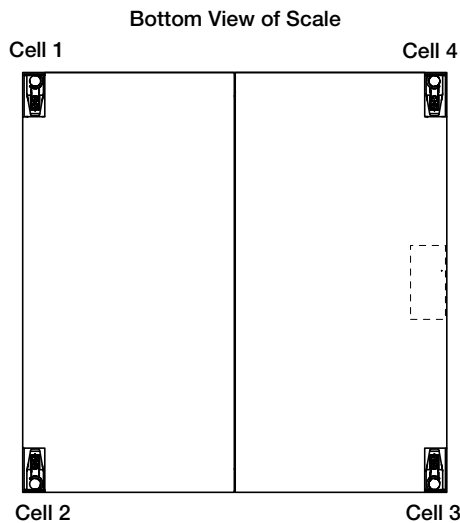

Figure 4-2. Bottom View of Scale

Check that the threaded holes for the load cell screws are free of debris. Use compressed air to blow out holes, if necessary. Position load cells with alignment arrows pointing up toward the deck. Loosely install the provided hex head cap screws as shown in Figure 4-1. Position the load cell to be centered within the channel. See Figure 4-3. Tighten all bolts to 250 ft-lb with a torque wrench.

**!** **Important** Do not cut load cell cables.

Coil extra cable before it enters the junction box, tie with cable ties and insert the coils into the channel.

After coiling excess cable, pass each individual end of the load cell cable through the cord grip in the junction box.

Corner trimming and calibration is necessary after load cell replacement.

Follow the instructions in Section 3.2 on page 8.

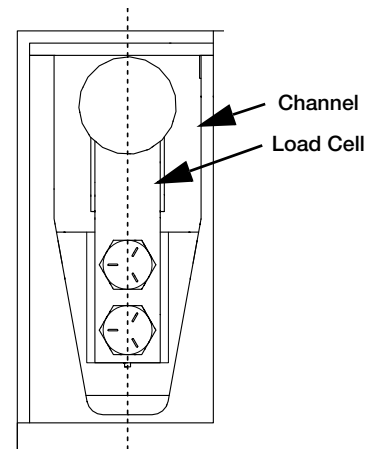

Figure 4-3. Center Load Cell

## 4.4 Load Cell Wiring to Junction Box

The four load cells are each wired to their respective terminals in the junction box according to the corner numbering system shown in Figure 4-2 and the coloring code in Table 4-2.

Pull excess cable out of the junction box enclosure and tighten the cord grip dome nuts with a wrench. To be watertight, the nuts must be tightened to the point where the rubber sleeving begins to protrude out of the nut. Finally, pull on each of the four cables to make sure that they do not slip.

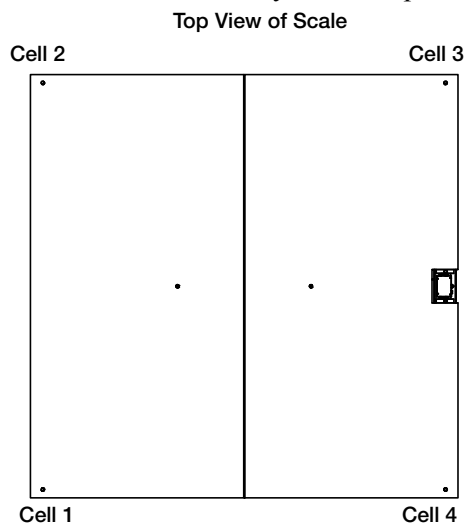

Figure 4-4. Corner Numbering - Top View

Color Cable Code	Junction Box Terminal
Red	+ Excitation
Black	- Excitation
Green	+ Signal
White	- Signal
Bare or Clear	Shield

Table 4-2. Load Cell Wiring



## 4.5 Dimension Drawings

### 4.5.1 RoughDeck AX-1 Scale

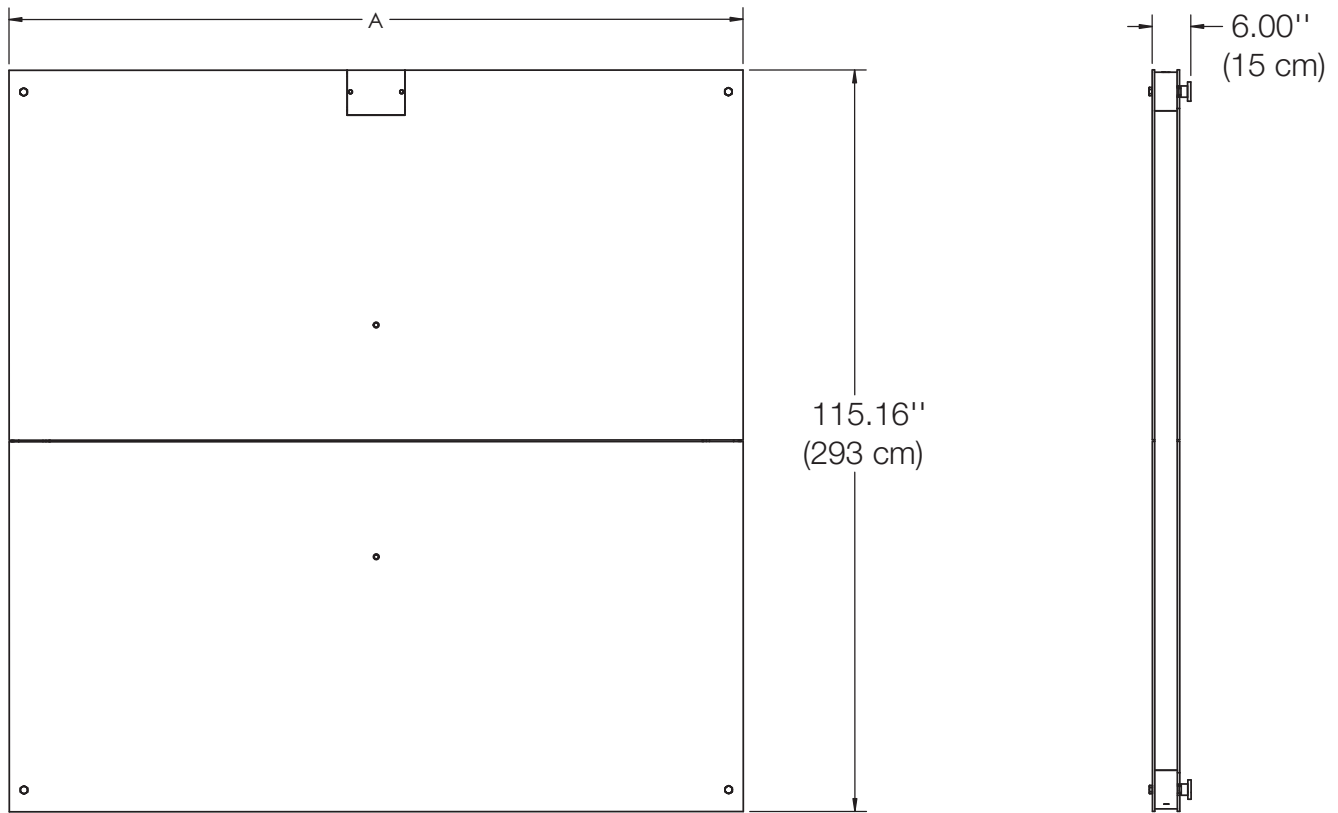

Figure 4-5. RoughDeck AX-1 Scale Dimensions Drawings

Description	A
RoughDeck AX-1 Scale 10'x8'	90.00" (229 cm)
RoughDeck AX-1 Scale 10'x10'	114.00" (290 cm)
RoughDeck AX-1 Scale 10'x12'	138.00" (351 cm)

Table 4-3. RoughDeck AX-1 Scale Dimensions

## 4.5.2 RoughDeck AX-1 Scale with Ramps

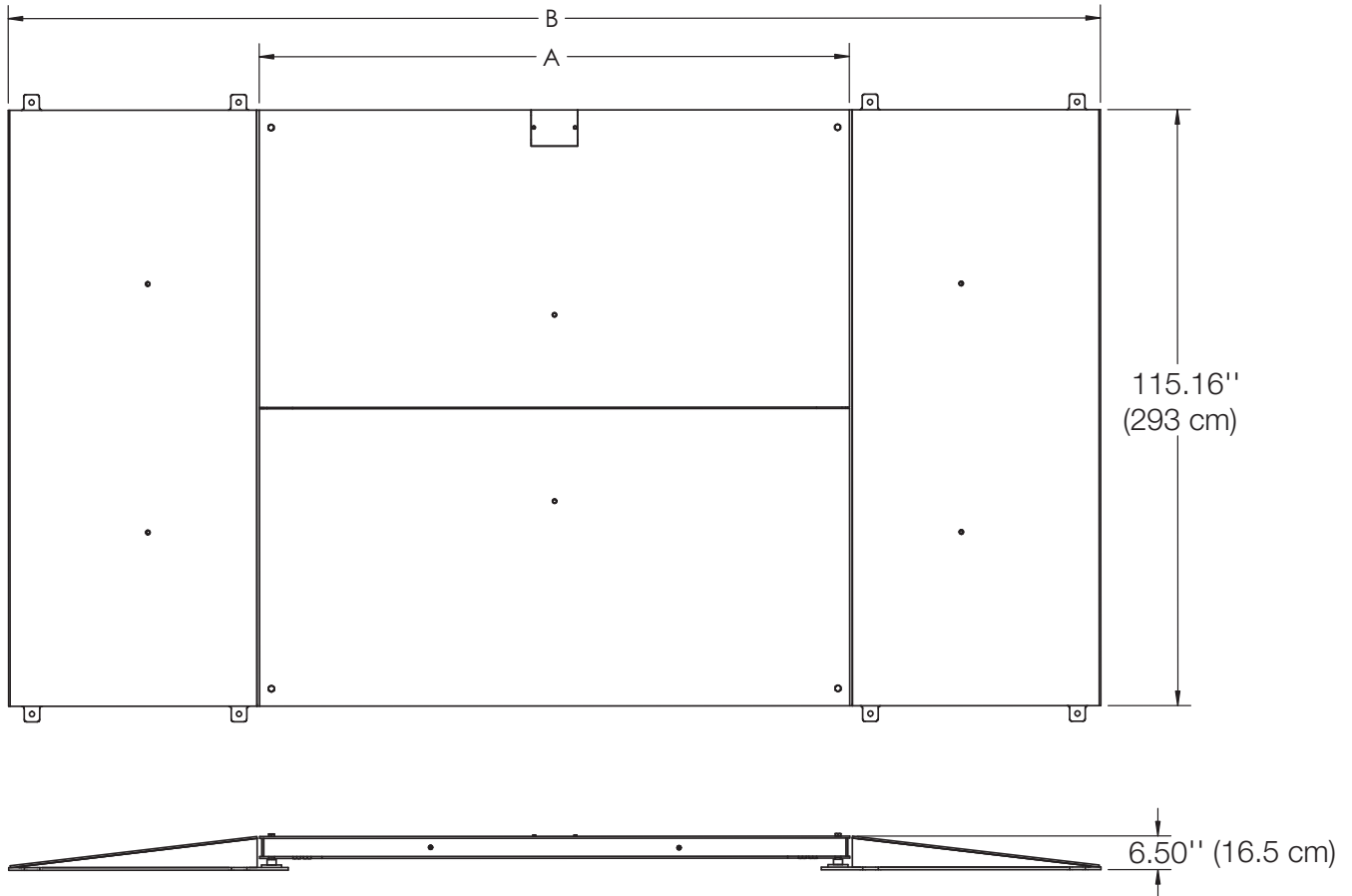

Figure 4-6. RoughDeck AX-1 Scale with Ramps Dimensions Drawing

Description	A	B
RoughDeck AX-1 Scale 10'x8' With Ramps	90.00'' (229 cm)	187.00'' (475 cm)
RoughDeck AX-1 Scale 10'x10' With Ramps	114.00'' (290 cm)	211.00'' (536 cm)
RoughDeck AX-1 Scale 10'x12' With Ramps	138.00'' (351 cm)	235.00'' (597 cm)

Table 4-4. RoughDeck AX-1 Scale with Ramps Dimensions

### 4.5.3 Frame

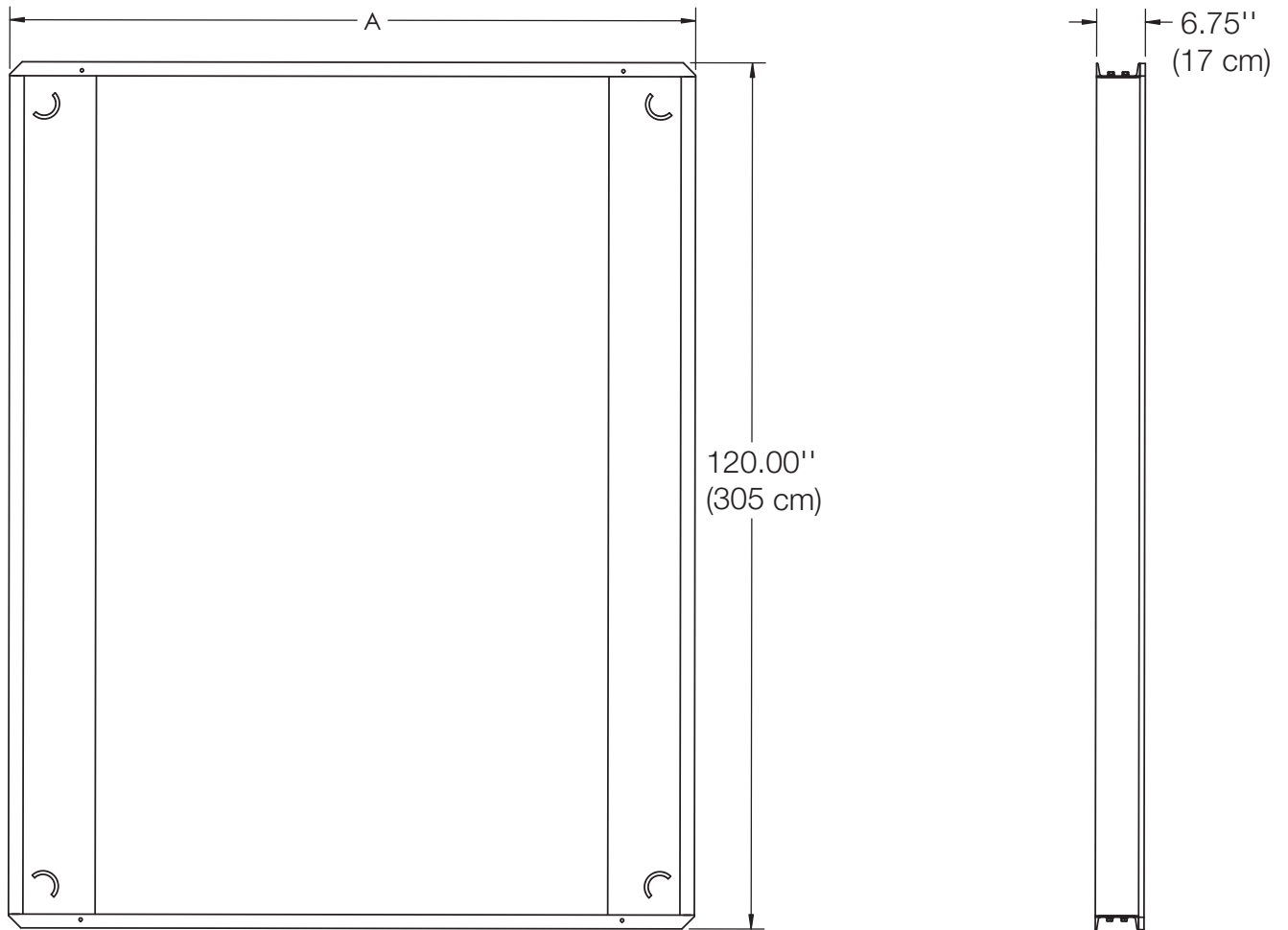

Figure 4-7. Frame Dimensions Drawing

Description	A
Pit Frame 10'x8'	95.00'' (241 cm)
Pit Frame 10'x10'	119.00'' (302 cm)
Pit Frame 10'x12'	143.00'' (363 cm)

Table 4-5. Frame Dimensions

#### 4.5.4 RoughDeck AX-1 Scale and Frame with Ramps

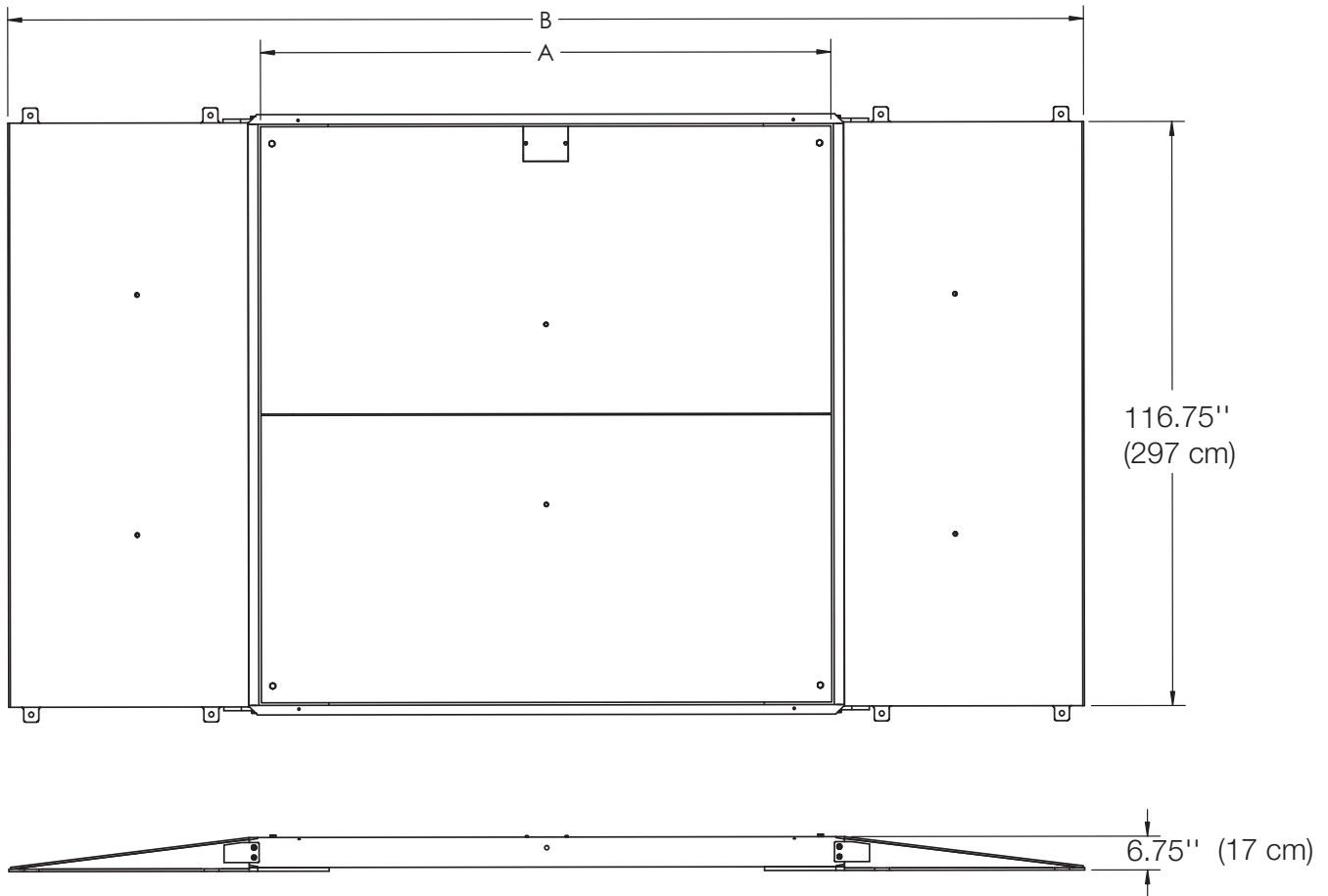

Figure 4-8. RoughDeck AX-1 Scale and Frame with Ramps Dimensions Drawing

Description	A	B
RoughDeck AX-1 Scale 10'x8' and Frame With Ramps	90.00" (229 cm)	191.00" (485 cm)
RoughDeck AX-1 Scale 10'x10' and Frame With Ramps	114.00" (290 cm)	215.00" (546 cm)
RoughDeck AX-1 Scale 10'x12' and Frame With Ramps	138.00" (351 cm)	239.00" (607 cm)

Table 4-6. RoughDeck AX-1 Scale and Frame with Ramps Dimensions





© Rice Lake Weighing Systems Specifications subject to change without notice.  
Rice Lake Weighing Systems is an ISO 9001 registered company.

230 W. Coleman St. • Rice Lake, WI 54868 • USA  
U.S. 800-472-6703 • Canada/Mexico 800-321-6703 • International 715-234-9171 • Europe +31 (0)26 472 1319

---

**[www.ricelake.com](http://www.ricelake.com) [www.ricelake.mx](http://www.ricelake.mx) [www.ricelake.eu](http://www.ricelake.eu) [www.ricelake.co.in](http://www.ricelake.co.in)**