

RoughDeck PC

Pancake Low-Profile Floor Scale

Installation Manual

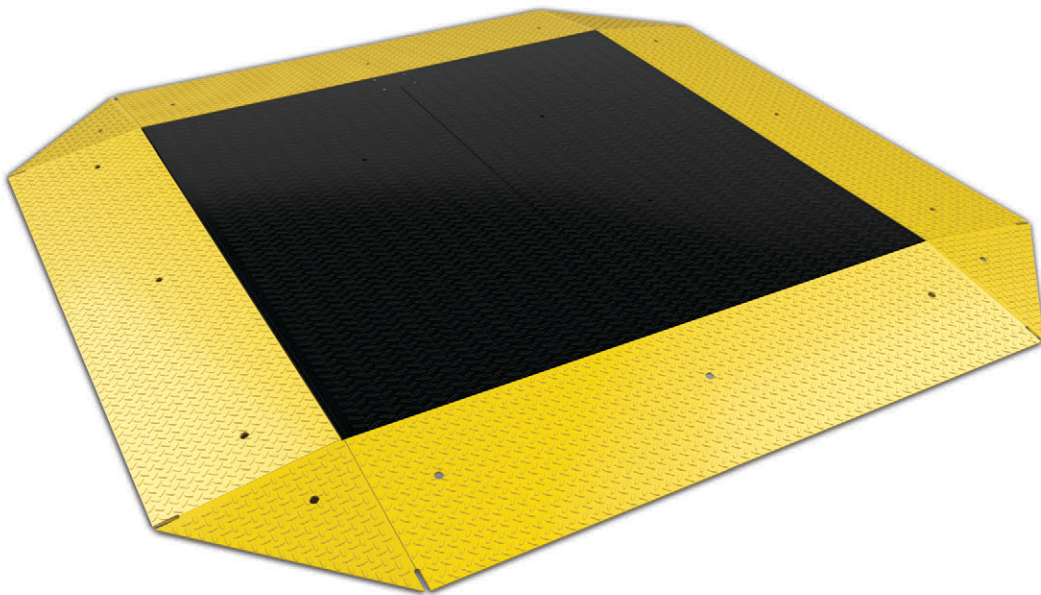

© Rice Lake Weighing Systems. All rights reserved.

Rice Lake Weighing Systems® is a registered trademark of
Rice Lake Weighing Systems.

All other brand or product names within this publication are trademarks or
registered trademarks of their respective companies.

All information contained within this publication is, to the best of our knowledge, complete and
accurate at the time of publication. Rice Lake Weighing Systems reserves the right to make
changes to the technology, features, specifications and design of the equipment without notice.

The most current version of this publication, software, firmware and all other product
updates can be found on our website:

www.ricelake.com

Revision History

This section tracks and describes manual revisions for awareness of major updates.

Revision	Date	Description
A	January 30, 2025	Initial release

Table i. Revision Letter History



Technical training seminars are available through Rice Lake Weighing Systems. Course descriptions and dates can be viewed at www.ricelake.com/training or obtained by calling 715-234-9171 and asking for the training department.

Contents

1.0 Introduction	5
1.1 Safety	5
1.2 Disposal	6
1.3 Operating Requirements	6
1.4 Dimensions	6
2.0 Installation	8
2.1 Installation Overview	8
2.2 Site Preparation	8
2.3 Unpacking	8
2.4 Assembly	9
2.4.1 Installing and Adjusting Feet	9
2.5 Junction Box Connections	9
2.5.1 Electrical Interface to Indicator	10
3.0 Adjustments and Calibration	11
3.1 Mechanical Adjustments	11
3.2 Corner Correction	11
3.3 Calibration Procedure	11
4.0 Service Information	12
4.1 Troubleshooting Guide	12
4.2 Periodic Maintenance	12
4.3 Load Cell Replacement	12
4.3.1 Load Cell Wiring to Junction Box	14



Rice Lake continually offers web-based video training on a growing selection of product-related topics at no cost. Visit www.ricelake.com/webinars

1.0 Introduction

The RoughDeck® PC Floor Scale is a fully electronic, low profile load receiver. The RoughDeck PC scale is 10 ft x 10 ft (3 m x 3 m) with 20,000 lb (10,000 kg) capacity. It uses four corner-mounted, FM-approved load cells, with the cells recessed into the frame channels for protection. Also included is a signal-trim summing board enclosed in a stainless steel, NEMA Type 4X junction box for any necessary corner corrections. All RoughDeck PC Floor Scales come pre-trimmed; corner corrections should not be necessary.

Load cell cables are enclosed in conduit through the main channels, and held down with replaceable cable ties near each corner, eliminating the possibility of cable damage in portable applications. Also useful for portable applications are threaded corner holes in the deck for removable eye bolts to allow lifting the scale from above with chains. Because of the possibility of foot and load cell damage from forklift tines, the scale should always be lifted from above with chains through the eye bolts.

The adjustable feet are used to allow leveling the scale to make up for minor floor irregularities. For permanent installations, two of the four feet can be held in place on the floor with optional floor mounting plates to guard against deck movement.

1.1 Safety

Safety Definitions:



DANGER: Indicates an imminently hazardous situation that, if not avoided, will result in death or serious injury. Includes hazards that are exposed when guards are removed.



WARNING: Indicates a potentially hazardous situation that, if not avoided, could result in serious injury or death. Includes hazards that are exposed when guards are removed.



CAUTION: Indicates a potentially hazardous situation that, if not avoided, could result in minor or moderate injury.



IMPORTANT: Indicates information about procedures that, if not observed, could result in damage to equipment or corruption to and loss of data.

General Safety



Do not operate or work on this equipment unless this manual has been read and all instructions are understood. Failure to follow the instructions or heed the warnings could result in injury or death. Contact any Rice Lake Weighing Systems dealer for replacement manuals.



WARNING

Failure to heed could result in serious injury or death.

Before attempting to operate this unit, make sure every individual who operates or works with this unit has read and understands the following safety information.

Failure to heed may result in serious injury or death.

DO NOT allow minors (children) or inexperienced persons to operate this unit.

DO NOT operate without all shields and guards in place.

DO NOT jump on the scale.

DO NOT use for purposes other than weight taking.

DO NOT place fingers into slots or possible pinch points.

DO NOT use any load bearing component that is worn beyond 5% of the original dimension.

DO NOT use this product if any of the components are cracked.

DO NOT exceed the rated load limit of the unit.

DO NOT make alterations or modifications to the unit.

DO NOT remove or obscure warning labels.

DO NOT use near water.

Before opening the unit, ensure the power cord is disconnected from the outlet.

Keep hands, feet and loose clothing away from moving parts.

1.2 Disposal



Product Disposal

The product must be brought to appropriate separate waste collection centers at the end of its life cycle.

Proper separate collection to recycle the product helps prevent possible negative effects on the environment and to health, and promotes the recycling of the materials. Users who dispose of the product illegally shall face administrative sanctions as provided by law.

1.3 Operating Requirements

The following are basic operating requirements for the *RoughDeck* PC floor scale.

Electrical Grounding

For systems where the scale is connected to a 115 VAC circuit, the indicator must be directly connected to an earth ground with a ground interface cable of no more than 3Ω resistance throughout its length.

Load Cell Excitation

Rated Excitation: 10 VDC

Maximum Excitation: 15 VDC

Grade Level Requirements

The supporting surface for the four feet of the scale must be level within 1/4 in of horizontal.

1.4 Dimensions

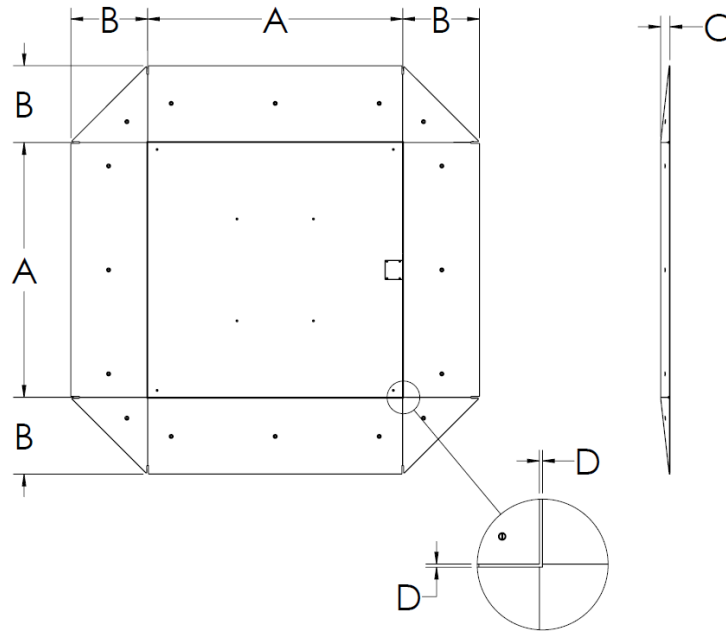

Figure 1-1. *RoughDeck* PC Dimensions

Side	Length (in)	Length (mm)
A	120.00	3048.00
B	35.80	909.32
C	4.37	110.00
D	0.38	9.65

Table 1-1. *RoughDeck* PC Dimensions

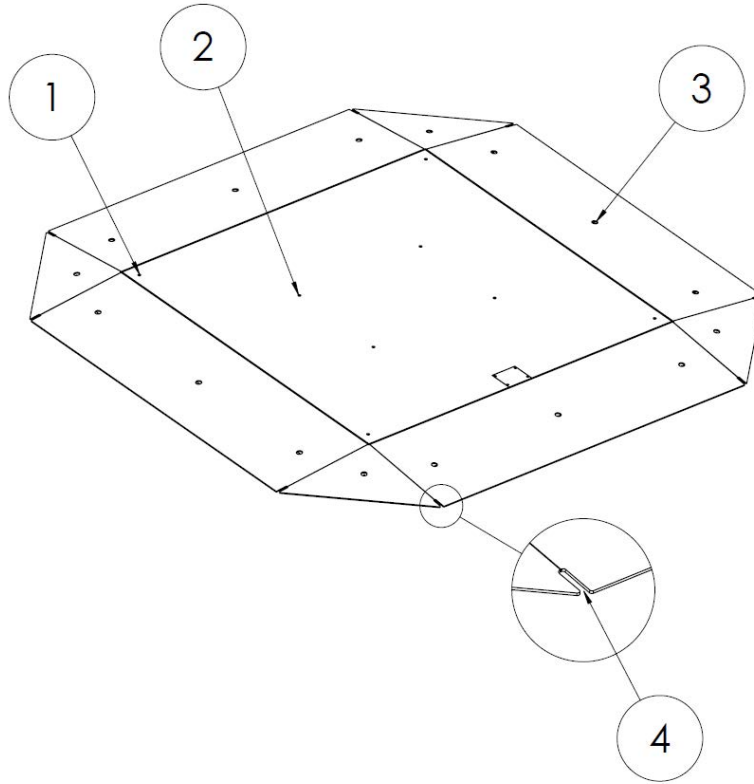

Figure 1-2. Hole Locations

No.	Function
1	Adjusts feet for ground contact
2	Screw in eye bolts to lift and relocate by crane
3	Anchor holes to keep bumpers in place
4	Slit to thread and secure wiring

Table 1-2. Hole Functions

2.0 Installation

2.1 Installation Overview

Standard installation of the *RoughDeck* PC floor scale consists of the following steps:

1. Select a site
2. Check the levelness and smoothness of the site
3. Unpack the scale and bumpers
4. Ensure the junction box side of the scale is closest to the indicator
5. Install scale feet in each corner load cell
6. Set ramps into position around the scale
7. Connect the cable to junction box and indicator
8. Route the cable out of corner nearest indicator
9. Level scale with foot adjust holes in each corner
10. Calibrate the unit

2.2 Site Preparation

The scale must not be loaded beyond its capacity, even momentarily. Do not select a site where overweight loads would have to maneuver to avoid crossing the platform. Avoid areas where the scale might receive damaging side impacts from wheels or forklift tines, or shock damage from falling objects. Avoid areas where water may damage a scale not meant for a washdown environment.

The interface cable between the scale and the indicator must be protected against crushing, cutting, or moisture damage. If the chosen site has such potential dangers, some method of protection, such as running the cable in conduit, will be necessary.

In operation, the scale must be level within 1/4 inch. Either choose a site where the floor is close to this standard to avoid excessive shimming, or modify the floor at the chosen site to meet this standard.

2.3 Unpacking

Remove all packing material and inspect scale for visible damage caused during shipment.

All *RoughDeck* models have threaded holes in the deck to allow installation of eye bolts with shoulders for use when lifting the scale with chains or using a spreader bar.



IMPORTANT: Lift the scale only with a properly designed spreader bar as shown in Figure 2-1. Lifting force must be vertical to avoid bending the eye bolts.



WARNING: Eye bolts must always be inserted into the top of the scale. Lifting should always occur with the top plate facing up and the eye bolts securely attached through the nuts welded to the bottom side of the top plate. Lifting from the bottom of the plate could cause nuts to break loose and the scale to fall.

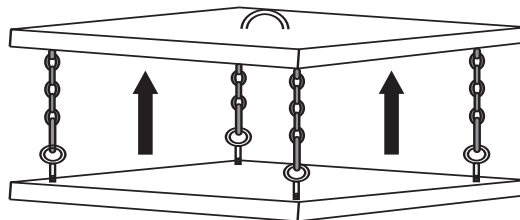

Use two 3/4 in eye bolts, insert into threaded holes in opposite corners of top plate for lifting.

Figure 2-1. Proper Lifting Technique

2.4 Assembly

The following paragraphs present instructions for installing and adjusting the scale feet and mounting plate installation.

2.4.1 Installing and Adjusting Feet

For load cell protection during shipping, the scale feet are shipped detached from the load cells. The feet are secured to the bottom of the shipping pallet along with the load cell cable, strain relief fitting and product literature. Remove all parts from the envelope.

Screw one foot into each load cell and turn all the way in until the foot touches either the load cell or the underside of the deck. Then unscrew each foot three complete turns.

Place a spirit level on the deck. Adjust any high corners not in contact with the floor by further unscrewing the feet on those corners until they just contact the floor surface. When all feet are in contact with the floor, check the deck with the spirit level to be sure the scale is within 1/4 inch of level.

2.5 Junction Box Connections

The indicator terminal strip is used to connect the main cable to the indicator which is shown in [Figure 2-2 on page 9](#). Determine the indicator's load cell input connections from the operating manual. Run a cable from your indicator terminal into the junction box and make the connections. The following table shows the correct junction box connections using the cable color code.

Cable Color Code	Junction Box
Red	+ Excitation
Black	- Excitation
Green	+ Signal
White	- Signal
Brown	Shield
Yellow	+ Sense
Blue	- Sense

Table 2-1. Junction Box Connections

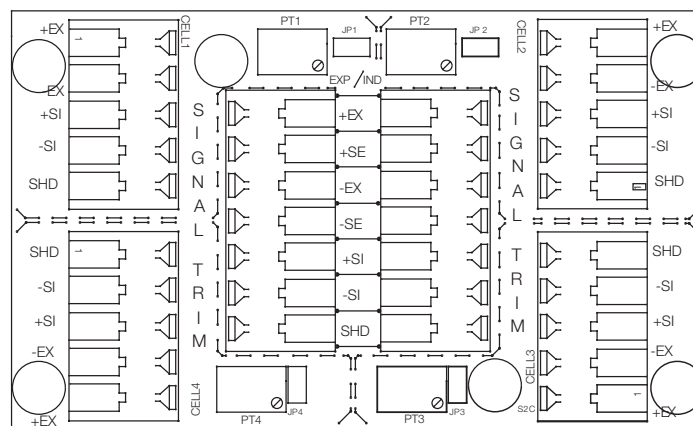

Figure 2-2. Junction Box Indicator Terminal

2.5.1 Electrical Interface to Indicator

Twenty feet of 6-wire cable to connect the scale to the weight indicator is supplied with each scale. The cable must be routed to the indicator in a manner that will protect the cable from damage. Two methods of cable protection in non-washdown applications are shown. When planning cable routing with either of these two methods, leave a loose coil of excess cable under the scale to facilitate future lifting of the scale for servicing or cleaning.

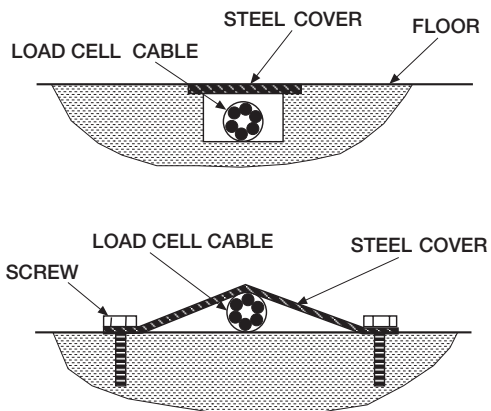

Figure 2-3. Electrical Interface to Indicator

When the interface cable is protected and in its final position, complete connections to the indicator. See indicator installation manual for wiring information.

If necessary, trim corners as described in [Section 3.2 on page 11](#).

Check all strain relief fittings for tightness.

Slide the junction box assembly into the cutout and secure it with the two #10 x 3/8 inch screws provided.

3.0 Adjustments and Calibration

3.1 Mechanical Adjustments

To accommodate minor floor unevenness, scale feet can be used to adjust scale height up or down a fraction of an inch. Use a flat head screwdriver in the foot adjustment holes to adjust the feet until they contact the floor equally. No jam nuts are supplied for locking the feet, as there is a slight decrease in accuracy when jam nuts are tightened. If the application requires the feet to be secured, use Teflon tape or Loctite.



CAUTION: When adjusting scale feet, use care to prevent scale foot from bottoming out against the underside of the load cell. Also, the foot stem may be damaged by bending or stripping threads if extended beyond the maximum height adjustment.

When height adjustments are complete, recheck level of the deck with a spirit level. The deck must be level within 1/4 in.

3.2 Corner Correction

All assembled *RoughDeck* PC scales are delivered with the junction box corner-trimmed. Corner trimming is only necessary after replacing a load cell.

To calibrate the scale, the output from each load cell must be matched by adjusting the signals with potentiometers at the junction box. This process is known as trimming.

Remove the junction box cover and identify the correct load cell terminal corresponding to each corner (labeled CELL 1, CELL 2, and so on). See [Figure 4-4 on page 14](#) for scale deck corner numbering.

The indicator must be connected and calibrated approximately, but it need not indicate the exact weight value. A test weight will be required. The recommended test weight for all *RoughDeck* models is 25% of scale capacity: for example, 500 lbs for 2K-lb models, 5000 lb for 20K-lb models.

With no weight on the scale, zero the indicator. Then turn all four potentiometers (shaded areas of Figure) to increase the reading until a clicking sound is heard from each potentiometer. This ensures the maximum signal from each load cell.

With all potentiometers at full signal, place the test weight over one corner and record the indicated weight. Repeat the process for each of the other three corners. The load cell with the lowest corner reading will be used as a reference point and will not be trimmed.

Next, place the test weight over one of the other three corners and use that cell's potentiometer to adjust the cell output down to the reference cell output. Repeat this procedure with the other two high corners.

Adjustments are somewhat interactive, and adjusting the three higher outputs may affect the reference cell output, especially in smaller scale decks. Rezero the indicator and repeat the test until all corners read within $\pm 1\%$ of the test weight used.

3.3 Calibration Procedure

Refer to the indicator manual to determine correct calibration procedures.

It is recommended that the scale be "exercised" before calibration to be certain that everything is seated. Load the scale to near capacity two or three times.

Then, with no load on the scale, place the indicator in its calibration mode and perform a zero calibration. Now place test weights on the platform equal to 70% - 80% of the scale's capacity. If several weights are used, they should be evenly distributed around the platform. Perform a span calibration.

Remove the test weights and check the zero reading. Repeat the calibration process if necessary.

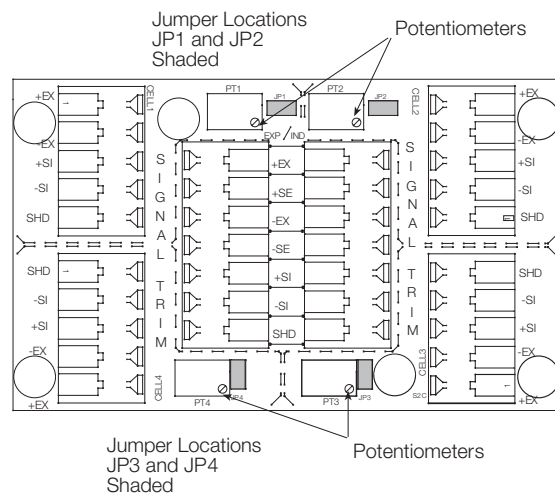

Figure 3-1. Trim Potentiometers

4.0 Service Information

4.1 Troubleshooting Guide

Issue	Possible Cause	Solution
System does not operate - no display	Power disconnected.	Check and reconnect.
	Indicator fuse blown.	Replace fuse. Check for cause.
	Interface cable cut or disconnected.	Repair.
	Signal leads incorrectly installed at indicator.	Install according to indicator installation manual
Display stays at zero	Indicator faulty.	<i>Service indicator</i>
	Load cell connections faulty.	Check cable connections in junction box and at indicator
Erratic weights	Vibration near scale.	Remove source of vibration or move scale.
	Platform not level to within 1/4 inch	Level scale by adjusting feet or shimming if necessary.
	Load cell or cable water damage	Replace
	Debris under load cells or platform	Clean
	Indicator faulty	Use simulator to test indicator for stability. Service indicator.
Consistently high or low weights	Indicator not properly adjusted to zero:	Zero the indicator according to indicator manual.
	Platform binding.	Obtain adequate clearance for free platform movement.
	Indicator not calibrated.	Calibrate according to indicator manual and Section 3.3 on page 11
	Load cells faulty.	Test and replace load cells if necessary.
	Feet touching deck underside.	Adjust feet downward to provide clearance.

Table 4-1. Troubleshooting

4.2 Periodic Maintenance

The space between the platform side and pit frame, and the surface beneath the platform must be periodically cleaned to prevent debris build up. More frequent cleaning of these areas is necessary with scales mounted in pits.



CAUTION: Do not attempt to use scales with load cells that are not hermetically sealed in washdown applications. Water damage is a common cause of failure in non-hermetically-sealed load cells. Use care with high pressure steam wash downs for hermetically-sealed load cells. The steam may not damage the load cells, but the elevated temperatures may cause incorrect readings until the unit cools to room temperature.

4.3 Load Cell Replacement

Lift scale with chains and proper spreader bar and remove foot, then remove defective load cell. Disconnect load cell cable from junction box and cut cable ties. When the cable is freed, pull cable out of the scale frame channels.

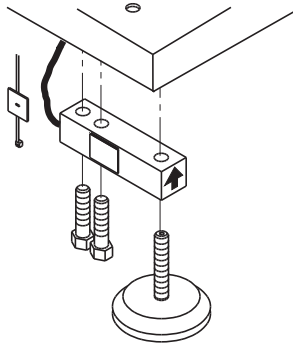

Figure 4-1. Load Cell Assembly

Follow the directions given below to install new load cells.

Overload stops should be loosened two full turns before installing new load cells. To reset overload stops after load cell installation, place a weight equal to 25% of the load cell capacity on the affected scale corner. Screw in the overload stop until the indicator reading changes. Then back off the overload stop 1/6 turn. Repeat for each corner where the load cell has been changed.

Lay out the four load cells near the corners where they are to be installed. Thread the cable from each load cell through the conduit tubing in the frame and into the junction box according to the wiring diagram in [Figure 4-2](#).

Note that in [Figure 4-2](#) both the scale and the junction box are viewed from the bottom. To verify correct load cell/junction box terminal matching, see the numbers on the terminals inside the junction box and the corner numbering diagram in [Figure 4-4](#).

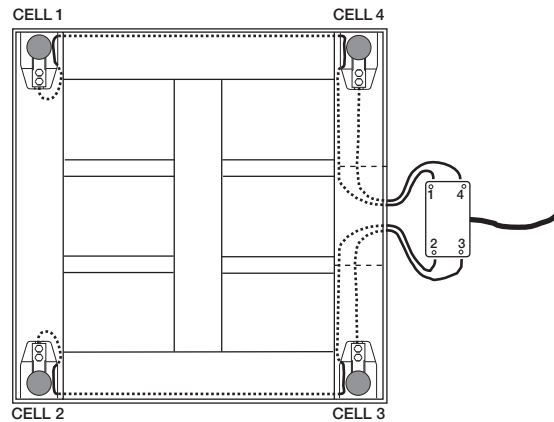

Figure 4-2. Bottom View of Scale

Check that the threaded holes for the load cell screws are free of debris. Use compressed air to blow out holes if necessary. Position load cells with alignment arrows point up toward the deck and loosely install the hex head cap screws provided, as shown in [Figure 4-1](#). If the base is used with a pit frame or access ramp, position the load cell to maintain the dimension shown in [Figure 4-3](#). With the torque wrench, tighten all bolts (outboard bolts first) to 250 ft-lb.

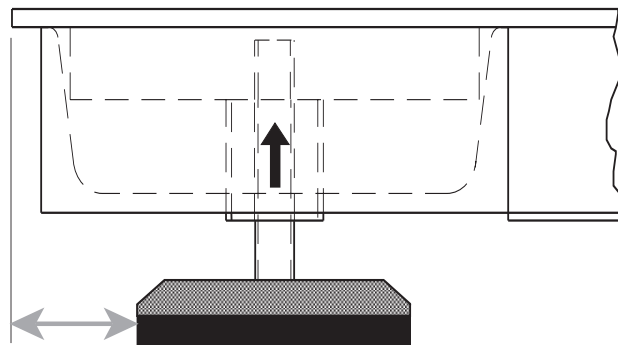

Figure 4-3. Foot Pad - Side View

Route the load cell cables near each corner so that the cable is free from possible contact with each foot. Hold the cable in position with the adhesive-backed cable ties supplied in the hardware kit.

Do not cut load cell cables. Coil extra cable before it enters the junction box, tie with cable ties, and insert the coils into the channel.

After coiling excess cable, pass each individual end of load cell cable through its cord grip in the NEMA Type 4X junction box. Corner correction trimming and calibration is necessary after load cell replacement. Follow instruction in [Section 3.2 on page 11](#) and [Section 3.3 on page 11](#).

4.3.1 Load Cell Wiring to Junction Box

The four load cells are each wired to their respective terminals in the junction box according to the corner numbering system shown in [Figure 4-4](#), and the coloring code in [Table 4-2](#).

Pull excess cable out of the junction box enclosure and tighten the cord grip dome nuts with a wrench. To be watertight, the nuts must be tightened to the point where the rubber sleeving begins to protrude out of the nut. Finally, pull on each of the four cables to make sure that they do not slip.

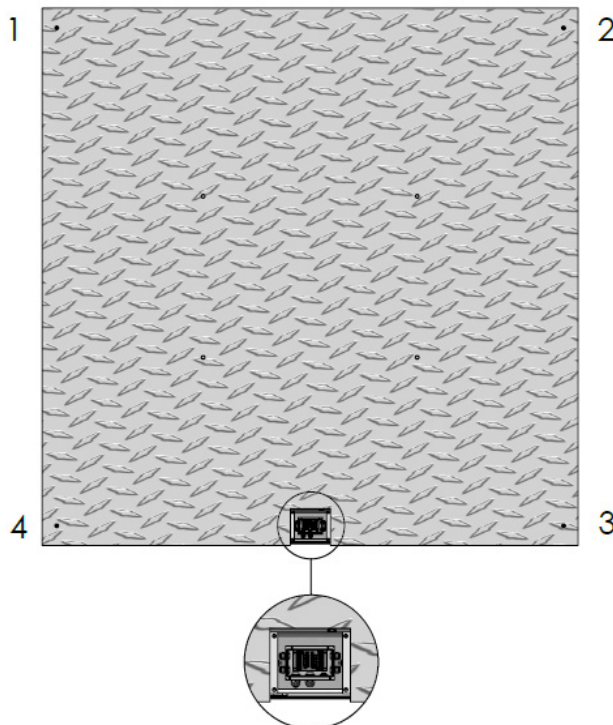

Figure 4-4. Corner Numbering - Top View

Color Cable Code	J-Box Terminal
Red	+ Excitation
Black	- Excitation
Green	+ Signal
White	- Signal
Bare or Clear	Shield

Table 4-2. Load Cell Wiring



© Rice Lake Weighing Systems Content subject to change without notice.

230 W. Coleman St. • Rice Lake, WI 54868 • USA USA: 800-472-6703 • International: +1-715-234-9171