

ScaleCore Webservice

Compatible with all ScaleCore-based MSI Products

Technical Manual



© Rice Lake Weighing Systems. All rights reserved.

Rice Lake Weighing Systems® is a registered trademark of
Rice Lake Weighing Systems.

All other brand or product names within this publication are trademarks or
registered trademarks of their respective companies.

All information contained within this publication is, to the best of our knowledge, complete and
accurate at the time of publication. Rice Lake Weighing Systems reserves the right to make
changes to the technology, features, specifications and design of the equipment without notice.

The most current version of this publication, software, firmware and all other product
updates can be found on our website:

www.ricelake.com

Revision History

This section tracks and describes the current and previous manual revisions for awareness of major updates and when the updates took place.

Revision	Date	Description
A	February 4, 2022	Initial manual release with the launch of the product
B	April 18, 2022	Rev history added; Wi-Fi connectivity updated due to antenna change
C	October 6, 2022	Quick start section added
D	December 13, 2024	Added: <ul style="list-style-type: none"> • Previously Paired Devices Setup • Disposal Warnings • Battery Removal Information • Troubleshooting Section

Table i. Revision Letter History



Technical training seminars are available through Rice Lake Weighing Systems. Course descriptions and dates can be viewed at www.ricelake.com/training or obtained by calling 715-234-9171 and asking for the training department.

Contents

1.0	Introduction	7
1.1	Safety	7
1.2	FCC Compliance	8
1.3	Disposal	8
1.4	Product Dimensions	9
1.5	Overlay Layout	10
2.0	Setup	11
2.1	Connection	11
2.1.1	Independent ScaleCore Webserver	11
2.1.2	ScaleCore Webserver with Wi-Fi Network	11
2.2	Quick Start	12
2.3	Manual Network Scan	14
3.0	Configuration	15
3.1	ScaleCore Webserver Interface	15
3.2	Connected Devices	16
3.3	Monitors Menu	16
3.3.1	Single Indicator	17
3.3.2	Multi Indicator	17
3.3.3	User Sum	18
3.4	Configuration Menu	19
3.4.1	Product Info	20
3.4.2	DAC Configuration	21
3.4.3	RF Configuration	23
3.4.4	Meter Features	24
3.4.5	Scan Lists	25
3.5	Load Cell Menu	26
3.5.1	General	27
3.5.2	Total	28
3.5.3	Math	29
3.5.4	Maintenance	30
3.6	Inputs / Outputs	31
3.6.1	Setpoints	32
3.6.2	Stream Print String	33
3.7	Network	38
3.7.1	Scan Devices	38
3.7.2	Network Setup	39
3.7.3	Previously Paired Devices Setup	40
3.8	User Group	41
3.8.1	Create User	42
3.8.2	Edit User	43
3.8.3	Remove User	43



Rice Lake continually offers web-based video training on a growing selection of product-related topics at no cost. Visit www.ricelake.com/webinars

4.0 Advanced Setup 44

4.1 Troubleshooting 44

4.2 Antenna Options 44

4.3 Server Updates 45

4.4 ScaleCore Webserver Mechanical Maintenance 45

 4.4.1 Open Enclosure 45

 4.4.2 Reseal Enclosure 46

 4.4.3 Cable Connections 46

 4.4.4 Replace Battery 47

4.5 Replacement Parts 48

4.6 Troubleshooting 50

5.0 Specifications 51



Technical training seminars are available through Rice Lake Weighing Systems. Course descriptions and dates can be viewed at www.ricelake.com/training or obtained by calling 715-234-9171 and asking for the training department.



Rice Lake continually offers web-based video training on a growing selection of product-related topics at no cost. Visit www.ricelake.com/webinars

1.0 Introduction

This manual is for configuration and service of the ScaleCore Webserver. The ScaleCore Webserver can be used to monitor and configure all MSI ScaleCore-based products. The ScaleCore Webserver provides a complete solution for ScaleCore family product networking and control. This manual supports all 3 available power supply options:

- ScaleCore Webserver 5 VDC (PN 207943)
- ScaleCore Webserver 7-14 VDC (PN 209704)
- ScaleCore Webserver 5 VDC w/ wall adapter (PN 210817)



Manuals are available from Rice Lake Weighing Systems at www.ricelake.com/manuals

Warranty information is available at www.ricelake.com/warranties

1.1 Safety

Safety Definitions:



DANGER: Indicates an imminently hazardous situation that, if not avoided, will result in death or serious injury. Includes hazards that are exposed when guards are removed.



WARNING: Indicates a potentially hazardous situation that, if not avoided, could result in serious injury or death. Includes hazards that are exposed when guards are removed.



CAUTION: Indicates a potentially hazardous situation that, if not avoided, could result in minor or moderate injury.



IMPORTANT: Indicates information about procedures that, if not observed, could result in damage to equipment or corruption to and loss of data.

General Safety



Do not operate or work on this equipment unless this manual has been read and all instructions are understood. Failure to follow the instructions or heed the warnings could result in injury or death. Contact any Rice Lake Weighing Systems dealer for replacement manuals.



WARNING

Failure to heed could result in serious injury or death.

Do not allow minors (children) or inexperienced persons to operate this unit.

Do not stand near the load being lifted as it is a potential falling hazard. Keep a safe distance.

Do not use for purposes other than monitoring and configuring Rice Lake Weighing Systems products.

Do not use any associated lifting product if any components of the load train are cracked, deformed, or show signs of fatigue.

Do not exceed the rated load limit of the associated Scale/Dynamometer unit, rigging elements, or the lifting structure.

Do not allow multi-point contact with the hook, shackle, or lifting eye of the associated Scale/Dynamometer unit.

Do not allow high torque on the Scale/Dynamometer unless it is specifically designed for high torque.

Do not make alterations or modifications to the unit or associated load bearing devices.

Do not remove or obscure warning labels.

For guidelines on the safe rigging and loading of overhead scales and dynamometers, read the "MSI Crane Scale Safety and Periodic Maintenance Manual" (available at www.ricelake.com).

Keep hands, feet and loose clothing away from moving parts.

There are no user serviceable parts within the ScaleCore Webserver. Any repairs are to be performed by qualified service personnel only.

1.2 FCC Compliance

United States

This equipment has been tested and found to comply with the limits for a Class A digital device, pursuant to Part 15 of the FCC Rules. These limits are designed to provide reasonable protection against harmful interference when the equipment is operated in a commercial environment. This equipment generates, uses, and can radiate radio frequency energy and, if not installed and used in accordance with the instruction manual, may cause harmful interference to radio communications. Operation of this equipment in a residential area is likely to cause harmful interference in which case the user will be required to correct the interference at his own expense.

Canada

This digital apparatus does not exceed the Class A limits for radio noise emissions from digital apparatus set out in the Radio Interference Regulations of the Canadian Department of Communications.

Le présent appareil numérique n'émet pas de bruits radioélectriques dépassant les limites applicables aux appareils numériques de la Class A prescrites dans le Règlement sur le brouillage radioélectrique édicté par le ministère des Communications du Canada.

1.3 Disposal



Product Disposal

The product must be brought to appropriate separate waste collection centers at the end of its life cycle.

Proper separate collection to recycle the product helps prevent possible negative effects on the environment and to health, and promotes the recycling of the materials. Users who dispose of the product illegally shall face administrative sanctions as provided by law.

Battery Disposal

Dispose of batteries at appropriate waste collection centers at the end of their life cycle in accordance with local laws and regulations. Batteries and rechargeable batteries may contain harmful substances that should not be disposed of in household waste. Batteries may contain harmful substances including but not limited to: cadmium (Cd), lithium (Li), mercury (Hg) or lead (Pb). Users who dispose of batteries illegally shall face administrative sanctions as provided by law.



WARNING: Risk of fire and explosion. Do not burn, crush, disassemble or short-circuit lithium batteries.

1.4 Product Dimensions

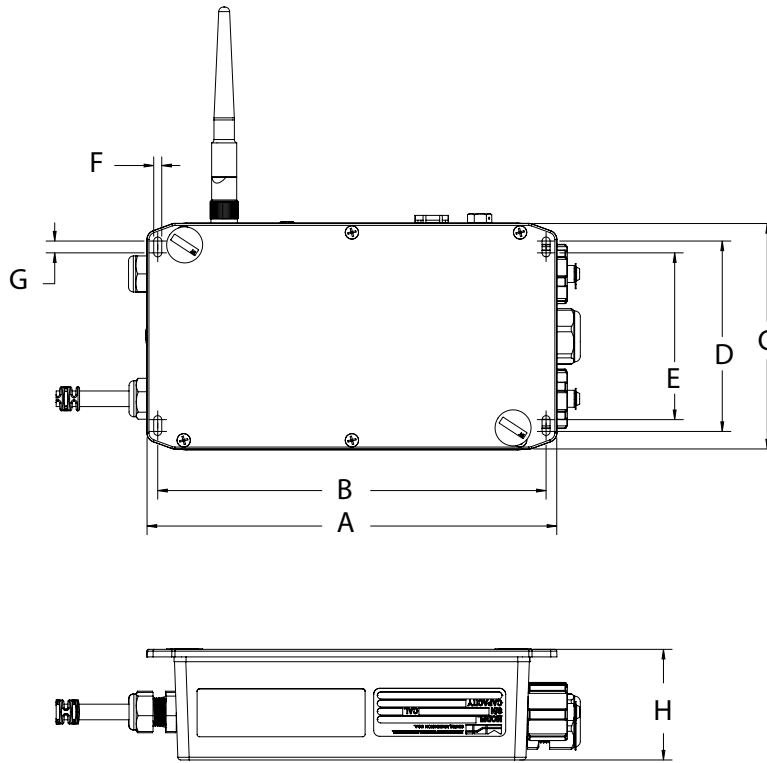

Figure 1-1. Product Diagram

A	B	C	D	E	F	G	H
8.540"	8.091"	4.700"	3.967"	3.474"	0.167"	0.246"	2.30"

Table 1-1. Product Dimensions

1.5 Overlay Layout

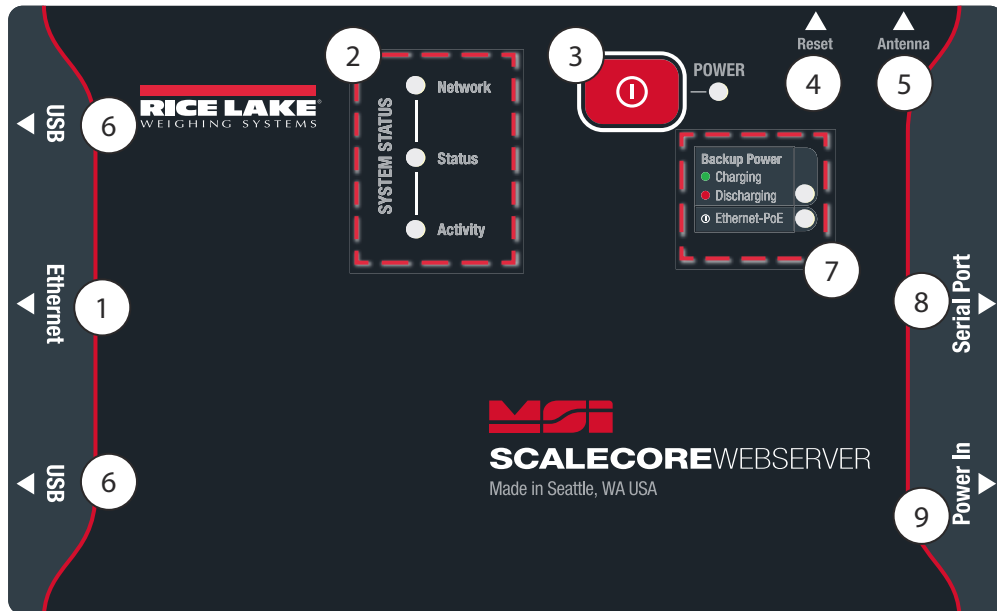

Figure 1-2. ScaleCore Webserver Overlay

Item No.	Description
1	Ethernet – RJ-45 (hardwire to TCP/IP connection)
2	System Status – indicate system status with network, status and activity annunciators
3	Power – Power button and Annunciator
4	Reset – Reset button
5	Antenna – Port for antenna
6	USB – Two USB ports
7	Power Annunciator – indicates backup power status Charging, Discharging, Ethernet PoE
8	Serial Port – RS-232
9	Power In – Location of Power cord

Table 1-2. Overlay Items

2.0 Setup

ScaleCore Webserver supports interfacing from an HTML browser on any network enabled device to MSI ScaleCore products. The ScaleCore Webserver is capable of functioning as an existing Wi-Fi network or as its own Wi-Fi router. The graphics below illustrate examples of the two setup options. Up to 7 devices can be connected directly to the ScaleCore Webserver in (Section 2.1.1), including any devices accessing the webserver through a web browser. If more than 7 devices are needed, an external access point may be created with a wifi router (Section 2.1.2).



NOTE: Recommended browsers are Microsoft Edge, Google Chrome and Safari. Outdated Browsers may cause issues.

2.1 Connection

The connection depends on the available interfaces of the ScaleCore product being used. Refer to the specific device manual for more details on the interface capabilities.

2.1.1 Independent ScaleCore Webserver

When the ScaleCore Webserver is independent of an existing network, all wireless devices connect directly to the ScaleCore Webserver. Only 7 total wireless devices may be connected directly to the ScaleCore Webserver. USB and serial devices are hardwired to the ScaleCore Webserver. If external access is needed, the ScaleCore Webserver can optionally be connected to TCP/IP network hardware.

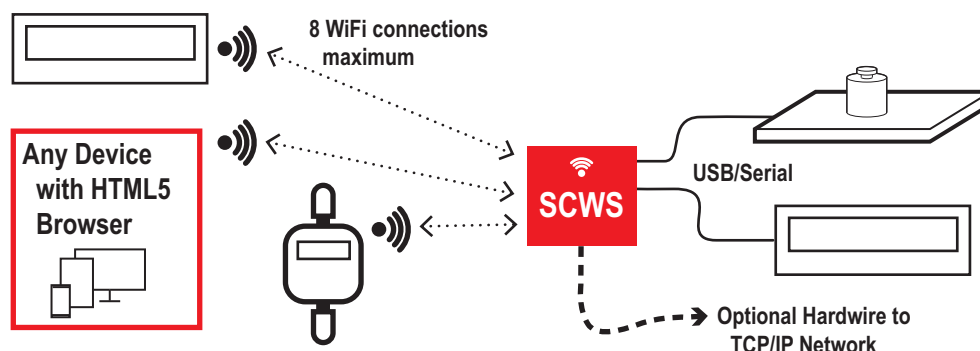

Figure 2-1. ScaleCore Webserver as Wi-Fi Network

2.1.2 ScaleCore Webserver with Wi-Fi Network

When the ScaleCore Webserver is integrated into an existing network, all wireless devices connect directly to the Wi-Fi router, USB and serial devices connect directly to the ScaleCore Webserver.

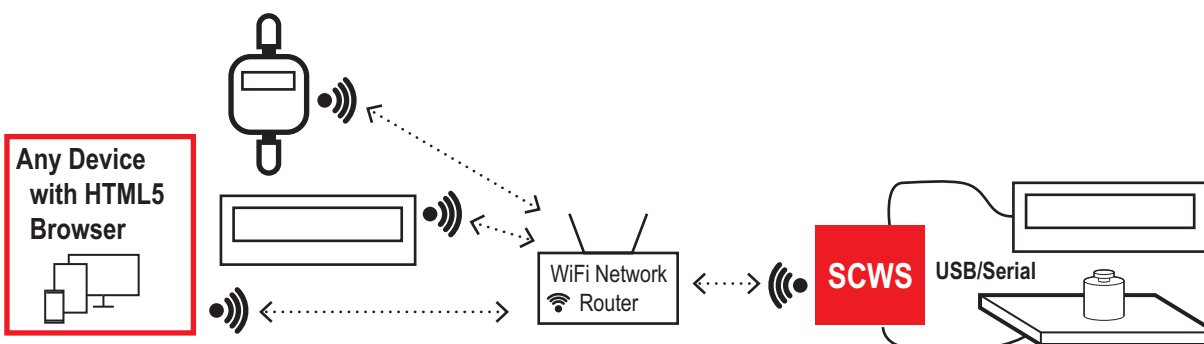

Figure 2-2. Connection Through Existing Wi-Fi Network

2.2 Quick Start

Devices must be powered on and scanned first for system-wide communications to be active.

1. Turn on all scales and devices associated with the system
2. Turn on the ScaleCore Webserver
3. Select the ScaleCore Webserver wireless network SSID using a PC, tablet or smart phone.



NOTE: SSID is "scserver" followed by the serial number of the ScaleCore WebServer; "scserver123456" for example

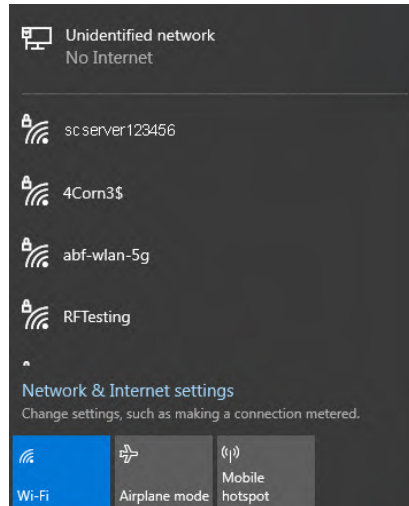

Figure 2-3. SSID

4. Enter the wireless password.



NOTE: Default password is "msi0199wf"

5. Open any HTML5 browser on the device.



NOTE: Recommended browsers are Microsoft Edge, Google Chrome and Safari. Outdated Browsers may cause issues.

6. Enter the programmed IP address followed by a colon and port 8080 (for example: http://10.171.1.72:8080/scserver).



NOTE: When PC, tablet, or smart phone is connected directly to the ScaleCore webserver wifi as in [Figure 2-1 on page 11](#), the default ip address is 192.168.1.1

Alternatively, "scserver.msi" may be used instead of the ip address (scserver.msi:8080/scserver)

The wired ethernet port has a DHCP client and should be connected to a network with DHCP server that will assign a IP address to the ScaleCore WebServer.

The login page may be saved as shortcut on the home screen or desktop. Do not save any pages as a favorite in a browser. Do not save any pages beyond the login wall.

If there is an unrecoverable error or other technical difficulty, close the browser and open a fresh login page to recover and re-scan.

- The following prompt displays when the device is connected to the ScaleCore Webserver:

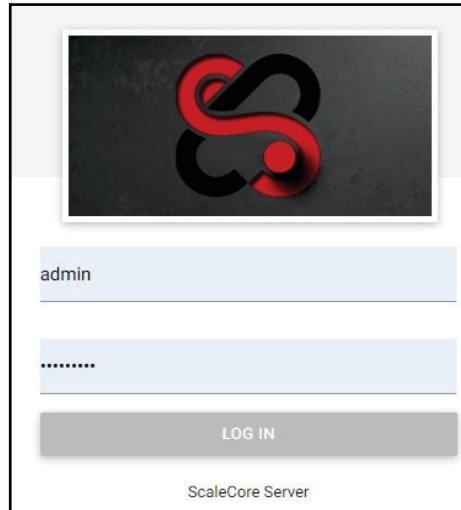

Figure 2-4. ScaleCore Webserver Login

- Enter User Name and Password.
 - Default User Name is **admin**
 - Default Password is **admin0199**



NOTE: Change Admin password during first log in to limit access to admin functions.
See [Section 3.8 on page 41](#) for more information on creating new users.

- Click **LOG IN**. The **ScaleCore Connected Devices** page displays.
- Ensure all scales and devices are listed.

2.3 Manual Network Scan

Upon initial login, system automatically scans for devices. If any expected ScaleCore scales, indicators or displays are missing from the connected devices list, perform server scan.

1. Select **Network** from the Scalecore Webserver Menu. (Figure 3-1 on page 15)
2. The following screen displays:

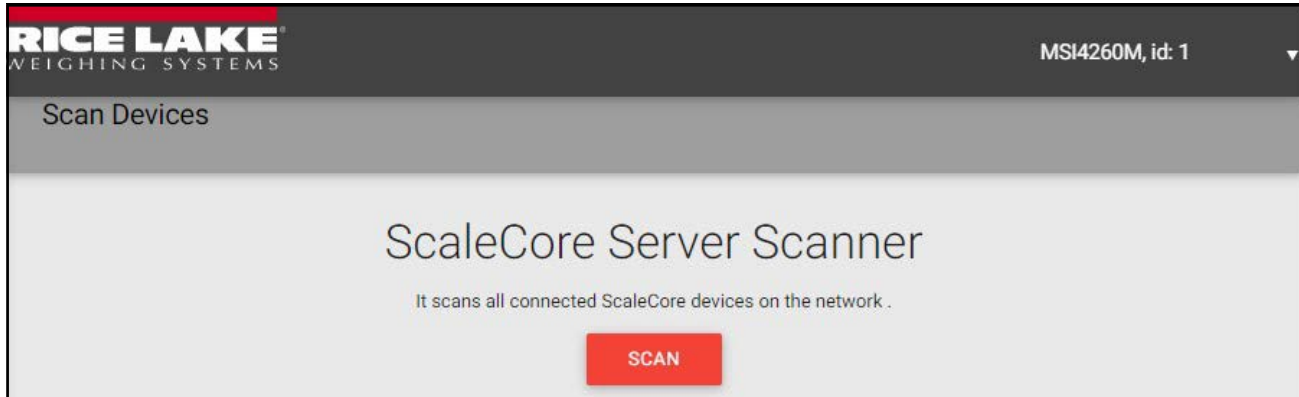

Figure 2-5. ScaleCore Server Scanner

3. Click **SCAN**. ScaleCore Webserver may take several minutes to displays connected devices (Figure 3-1 on page 15).



NOTE: Some devices may be delayed in connecting to the Webserver. If any devices from the system aren't displaying in the Connected Devices list, navigate to Network/Scan Devices and perform a scan. Repeat until all devices display.

If the ScaleCore board is replaced or ScaleCore connected device has been serviced or the firmware is updated, radio settings of the updated device must be updated to be compatible with the ScaleCore Webserver. Contact Rice Lake Weighing Systems for ScaleCore assistance.

3.0 Configuration

This section provides an overview of ScaleCore Webserver software configuration. This section is a guide for setting up the product being read by the ScaleCore Webserver.

3.1 ScaleCore Webserver Interface

Each page of the ScaleCore Webserver has the same navigation.

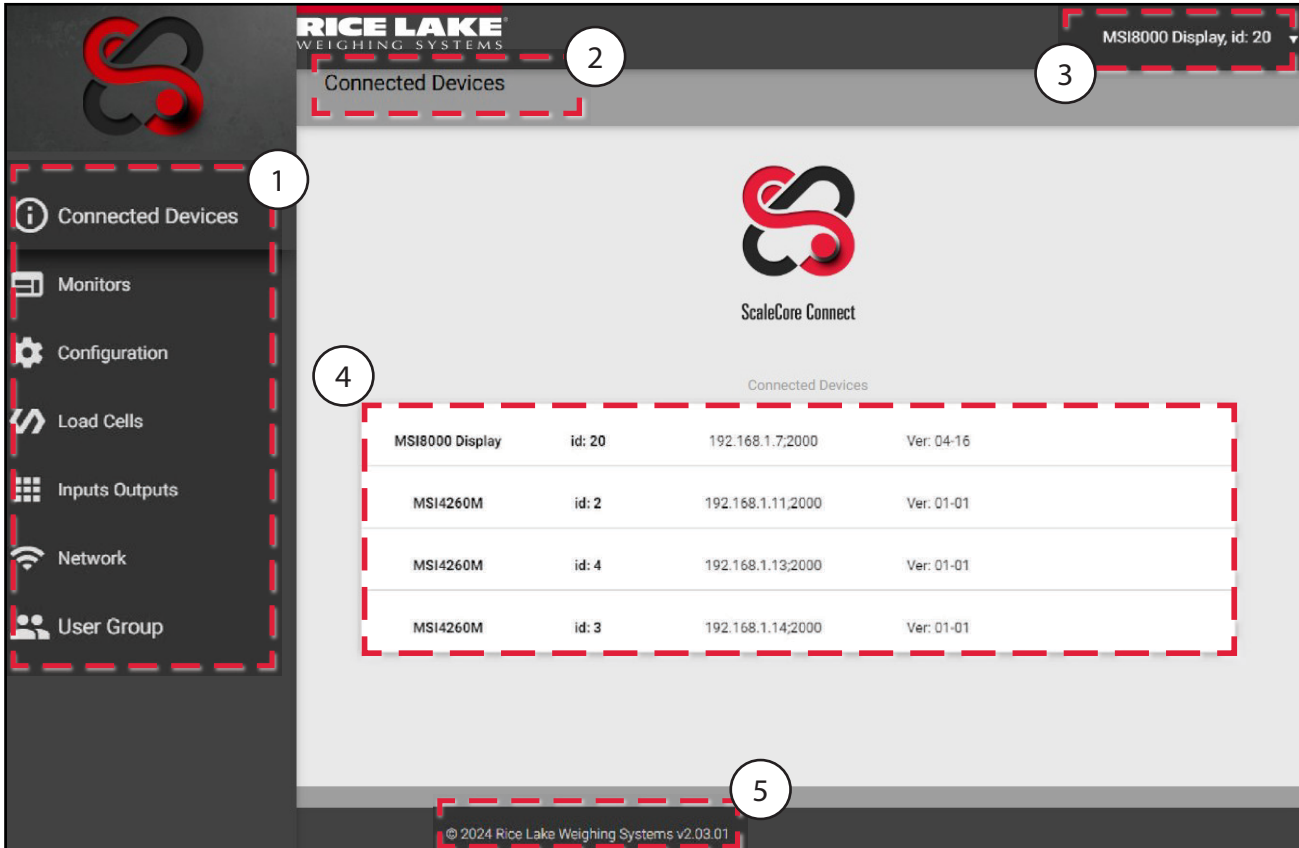

Figure 3-1. ScaleCore Webserver Interface

Number	Description
1	ScaleCore Webserver Menu
	Connected Devices — Displays currently connected devices that are powered on (see Section 3.2 on page 16)
	Monitors — Displays weight display of currently connected devices (see Section 3.3 on page 16)
	Configuration — Displays and enables changing of scale configuration (see Section 3.4 on page 19)
	Load Cells — Displays and enables changing of load cell configuration (see Section 3.5 on page 26)
	Inputs Outputs — Displays and enables changing of Setpoints and print streaming (see Section 3.6 on page 31)
	Network — Displays and enables changing of network configuration (see Section 3.7 on page 38)
User Group — Displays user accounts (see Section 3.8 on page 41)	
2	Page Title — Displays title of current screen information
3	Displayed Scale Identification — Displays model and id number of currently displayed scale information
4	Displayed Scale Information — Displays current screen information
5	Software Version Number — Displays copyright and current ScaleCore Webserver version number

Table 3-1. ScaleCore Webserver Interface

3.2 Connected Devices

Displays devices that are connected and powered on.

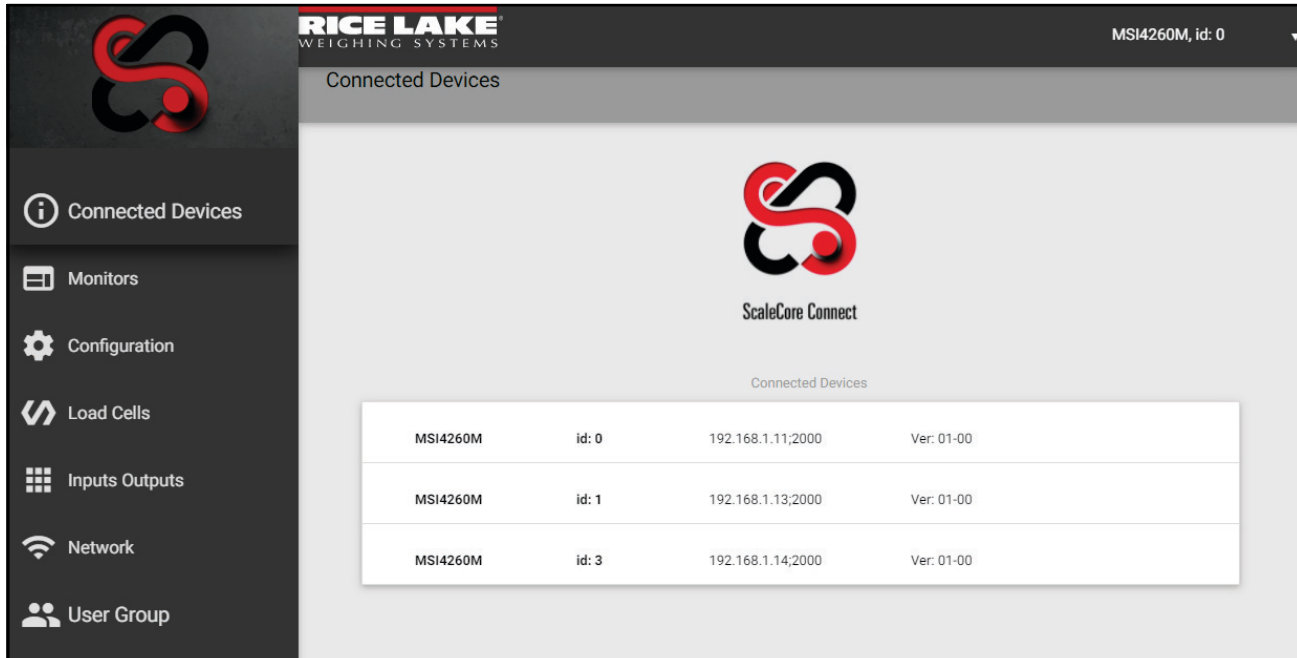

Figure 3-2. Connected Devices Screen



NOTE: If a connected device does not appear on this list, rescan the network ([Section 3.7 on page 38](#)) or power cycle the ScaleCore Webserver

3.3 Monitors Menu

The Monitors menu displays the three weight display options. Select **Monitors** in the ScaleCore Webserver menu. This section describes the Monitors menu and the three monitor options available.



NOTE: Remote Displays are not supported as indicators and will not display weight in the monitor menu.

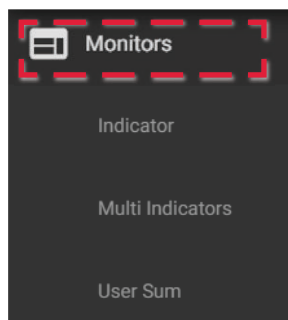

Figure 3-3. Monitors Menu

Option	Description
Indicator	Displays single indicator status and weight display Section 3.3.1 on page 17
Multi Indicators	Displays full indicator status of one indicator with a summary status of each of the connected indicators Section 3.3.2 on page 17
User Sum	Displays sum of one or more indicators Section 3.3.3 on page 18

Table 3-2. Monitors Menu Options

3.3.1 Single Indicator

Representation of single selected indicator scale display. Selected scale is displayed in the top right corner of the screen.

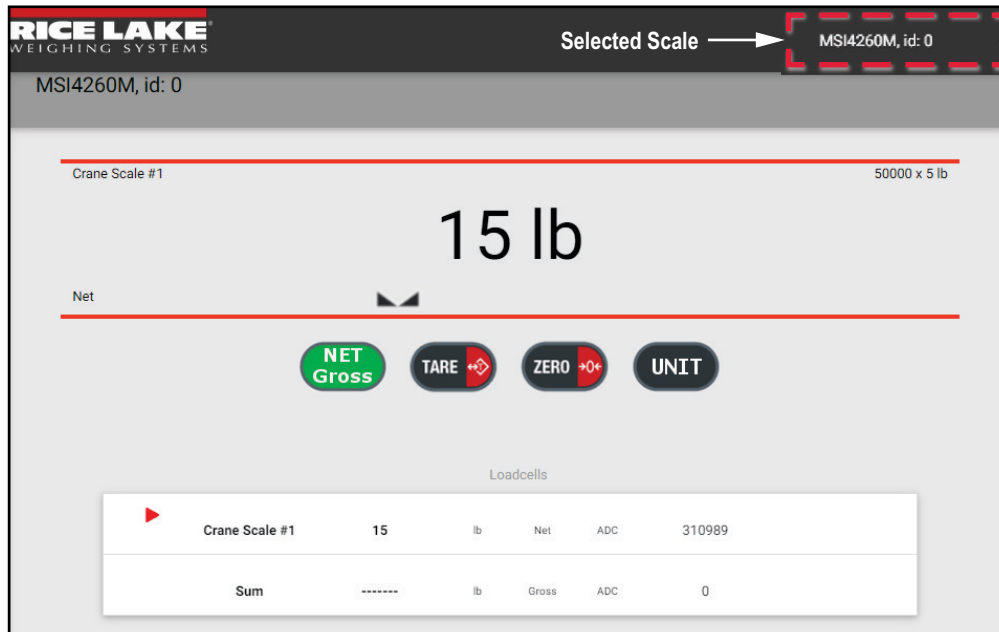

Figure 3-4. Single Indicator Scale Display

3.3.2 Multi Indicator

Displays full indicator status of the selected indicator with a summary status of each of the connected indicators. The active scale is marked by a red triangle pointer. Click on a scale to change the active scale.

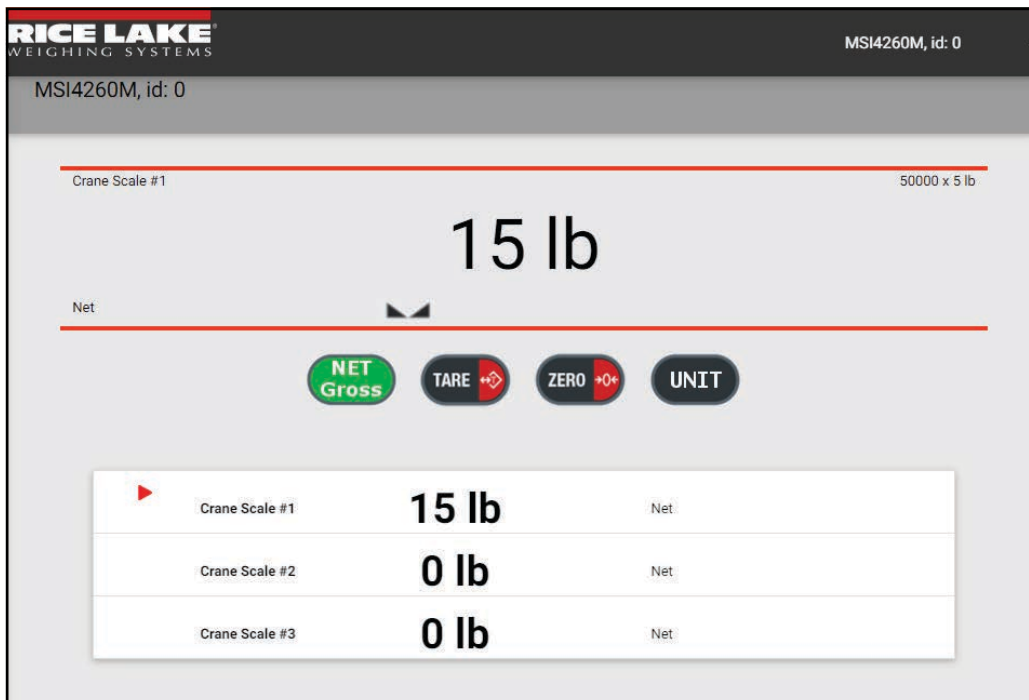

Figure 3-5. Multi Indicator Scale Display

3.3.3 User Sum

User Sum displays all available load cells. The following variations are available:

- Sum Mode — Displays Sum of all load cells toggled in the summed column
- Single Mode — Displays load of an selected single load cell

Sum of Selected Loadcells from All Connected Devices.

Sum 80000 x 5 lb

15 lb

Gross

NET Gross UNIT

Sum Mode → Sum Mode Single Mode ← Single Mode

Selected Load Cell in Single Mode →

Loadcells:					
Crane Scale #1	15	lb	Net	<input checked="" type="checkbox"/>	Summed
Crane Scale #2	0	lb	Net	<input checked="" type="checkbox"/>	Summed
Crane Scale #3	0	lb	Net	<input checked="" type="checkbox"/>	Summed

Selected Load Cells in Sum mode

Figure 3-6. User Sum Modes

3.4 Configuration Menu

The Configuration menu displays the titles of the configurable options. Select **Configuration** in the ScaleCore Webserver menu. This section describes the Configuration menu and all configurable options of a selected scale. Selected scale/device is displayed in the top right corner of the screen.

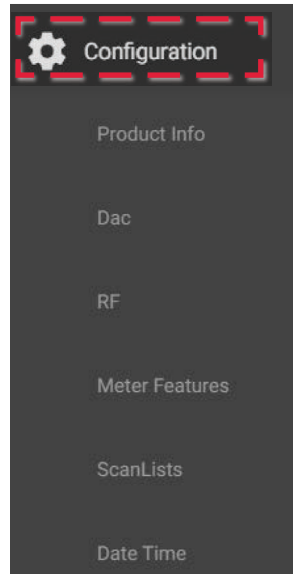

Figure 3-7. Configuration Menu

Option	Description
Product info	Displays product identification information Section 3.4.1 on page 20
Dac	Displays controls for DAC (Digital to Analog) output functions Section 3.4.2 on page 21
RF	Displays setup of radio frequency cards Section 3.4.3 on page 23
Meter Features	Displays parameters for remote displays Section 3.4.4 on page 24
Scan Lists	Displays list of remote devices connected to a remote display Section 3.4.5 on page 25
Date Time	Display sets current date and time on connected ScaleCore devices that support date and time; If there is no connected device with that supports Date and Time, display reads Remote device does not support Realtime Clock.

Table 3-3. Monitors Menu Options

3.4.1 Product Info

Displays product information.

! **IMPORTANT: Do not change these settings without consulting Rice Lake Weighing Systems or a local dealer.**

1. Select **Configuration** to expand the configuration menu [Figure 3-7 on page 19](#).
2. Select **Product Info**.
3. Confirm device from drop down menu in upper hand corner of screen.

Figure 3-8. Product Info Settings

4. Make any necessary changes in the following parameters:

Parameter	Description	
Device ID	Number given to the current product (selections: 1–255)	
User Defined Model	ATP 3 C Cells 6 D Cells 6V Battery 12V Battery 110V AC CHI 107 CHI 234 AC Power DC Power	Power source of current product; Used to set low battery light threshold; Parameter is set at the factory and should not be modified.
User Model Name	Enter a name for the product	
PCB Serial Number	Serial number for the PCB board, read only	
Product Serial Number	Serial number of displayed product, read only	
Software Version	Displays the version of software currently installed, read only	

Table 3-4. Product Info Settings Parameters

5. Press **SUBMIT** to save. New settings will not take affect until power is cycled on the connected device.

3.4.2 DAC Configuration

ScaleCore Webserver provides controls for DAC (Digital to Analog) output functions in ScaleCore products.

Controls include calibration and manual control. DAC configuration can only be used with products that have an analog output option installed

RICE LAKE
WEIGHING SYSTEMS

Selected Scale → MSI4260M, id: 1

DAC Configuration for: MSI4260M, id: 1

Dac Channel: 0, unCal

DAC Channel		Source Sensor ID	
0		1	
Status	Operation Mode	Unit	Value Type
Disabled ▼	Normal ▼	lb ▼	Gross ▼
Min Sensor Value	Max Sensor Value		
0	1000		
<input type="checkbox"/> Not Filtered Sensor Value		DAC Offset	
		0	
DAC Gain		Min DAC Count	
0		0	
Max DAC Count		Output Mode	
4095		0V to 5V ▼	

SUBMIT

Figure 3-9. DAC Configuration Screen

1. Select **Configuration** to expand the configuration menu [Figure 3-7 on page 19](#).
2. Select **DAC**.
3. Confirm device from drop down menu in upper hand corner of screen.
4. Make any necessary changes in the following parameters:

Parameter	Description	
DAC Channel	Select the channel to be used	
Source Sensor ID	Select a number 1–16	
Status	Select Disabled (default) or Enabled	
Operation Mode	Select Normal (default) or Manual	
Unit	lb kg Ton MTon oz gram k Newton V amp °C °F Kelvin Lux	Select unit to be used
Value Type	Gross Net Total Tare Zero Peak ADC count Current Mode	Select value type to be used
Min Sensor Value	Enter min sensor value acceptable	
Max Sensor Value	Enter max sensor value acceptable	
Not Filtered Sensor Value	Check box is applicable	
DAC Offset	Current calibration value	
DAC Gain	Current calibration value	
Min DAC Count	Enter min DAC Count acceptable	
Max DAC Count	Enter max DAC Count acceptable	
Output Mode	0V to 5V 0V to 10V +/- 5V +/- 10V 4-20mA 0-20mA 4-24mA	Select output mode to be used

Table 3-5. DAC Configuration Parameters

5. Press  to save.

3.4.3 RF Configuration

Allows the setup of RF (Radio Frequency) cards available in the products connected.



NOTE: See the individual MSI ScaleCore product manuals for proper RF setting configurations.

1. Select **Configuration** to expand the configuration menu [Figure 3-7 on page 19](#).
2. Select **RF**.
3. Confirm device from drop down menu in upper hand corner of screen.

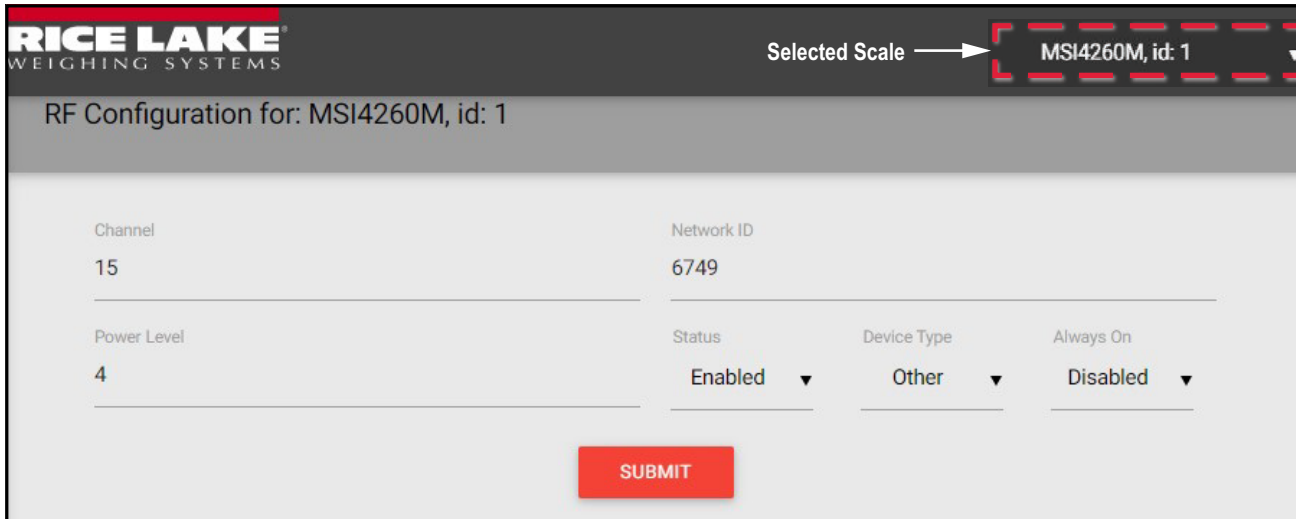

Figure 3-10. Product Info Settings

4. Make any necessary changes in the following parameters:

Parameter	Description
Channel	Select a channel from 12–23
Network ID	Enter a number from 0–65534 for an ID
Power Level	Select a level from 0–4
Status	Select Enabled (default) or Disabled
Device Type	Select XBee or Other (for all other cards installed)
Always On	Select Enabled (default) or Disabled

Table 3-6. RF Configuration Parameters



NOTE: Channel, Network ID, and Power Level are only used with the 802.15.4 radio option. If the device does not have a secondary 802.15.4 radio option installed, these settings will have no effect on the scale.

Changing the RF status may result in loss of connection between the scale and connected devices. Connection will need to be reconfigured using the front panel or the serial port.

Only set Always On to Enabled when using Rugged Remote. Having this parameter set to Enabled will drain the battery even when the scale is off. Disconnect the battery when not in use.

5. Press  to save. Power cycle the product to apply changes.

3.4.4 Meter Features

Meter Features are only available for remote display devices.

1. Select **Configuration** to expand the configuration menu [Figure 3-7 on page 19](#).
2. Select **Meter Features**.
3. Confirm device from drop down menu in upper hand corner of screen.

The screenshot shows the 'Meter Features Configuration' page for an MSI8000 Display. At the top right, a dropdown menu shows 'Selected Scale' pointing to 'MSI8000 Display, id: 26'. The main configuration area includes the following settings:

- Focus Loadcell ID: 0
- Max Number Loadcell: 2
- Reroute Mode: Disabled
- Summing Mode: Off
- Selected Summing Mode: None

Figure 3-11. Product Info Settings

4. Make any necessary changes in the following parameters:

Parameter	Description	
Focus Loadcell ID	Select a number from 1–5	
Max Number Load Cell	Select a number from 1–4	
Reroute Mode	Select Enabled or Disabled (default)	
Summing Mode	Off All Pairs Both User Defined	Select a combination to add loads
Selected Summing Mode	None All Pairs Loadcell 1 & 2 Pairs Loadcell 3 & 4	Select an option if further definition is needed for summing

Table 3-7. Meter Feature Settings Parameters

5. Press **SUBMIT** to save.

3.4.5 Scan Lists

A scan list is a list of remote devices/sensors (load cells) connected to a remote display. Remote displays are capable of supporting up to four remote sensors. See the connected device manual for more information on how the scan list works.

1. Select **Configuration** to expand the configuration menu [Figure 3-7 on page 19](#).
2. Select **Scan Lists**.
3. Confirm device from drop down menu in upper hand corner of screen.

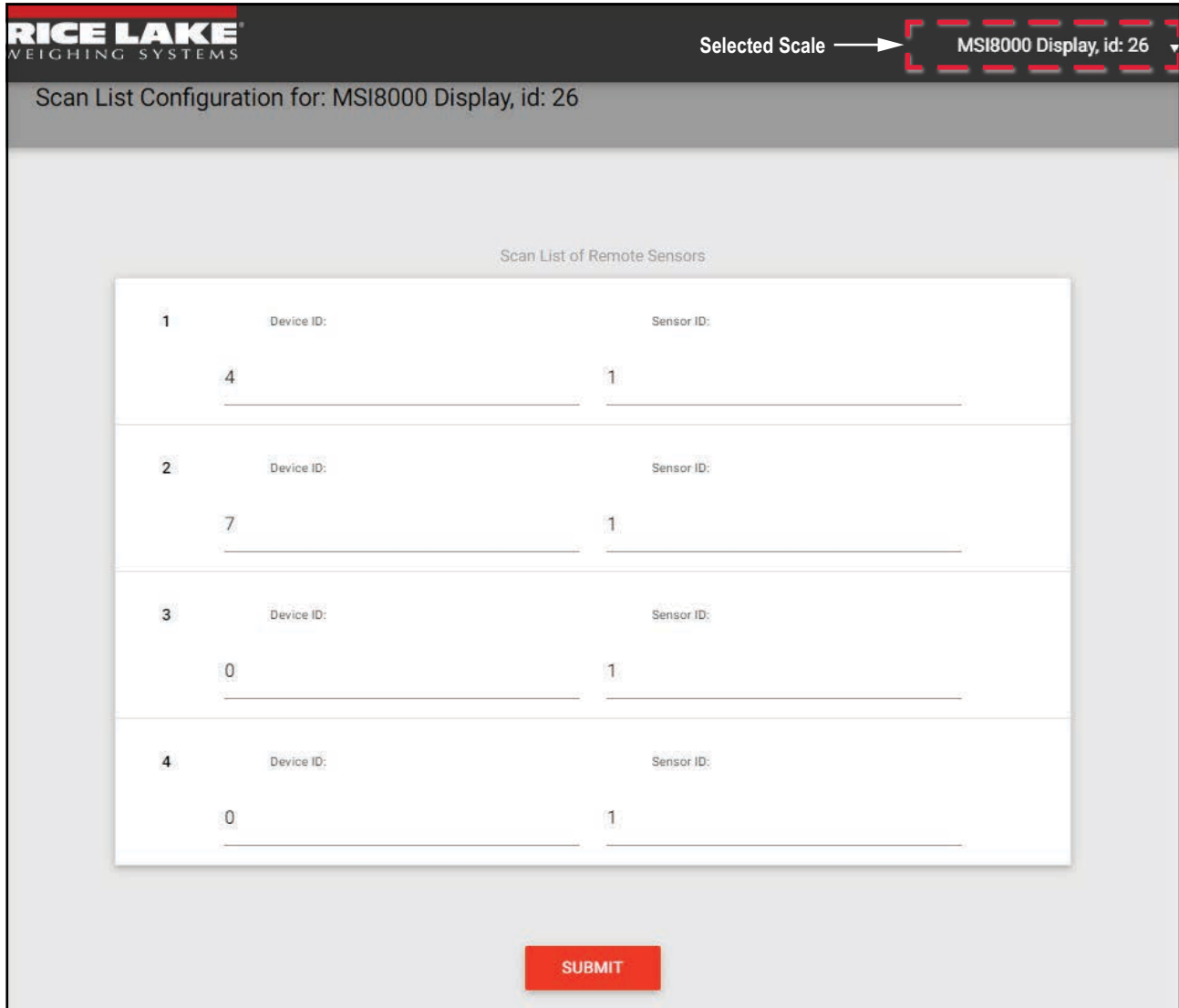

Figure 3-12. Product Info Settings

4. Make any necessary changes in the following parameters:

Parameter	Description
Scan List Number	Select a scan list number
Remote Device ID	Select a remote device ID number
Source Sensor ID	Select a source sensor ID number

Table 3-8. Sensor Scan List Settings Parameters

5. Press **SUBMIT** to save.

3.5 Load Cell Menu

Allows load cells parameters to be set for each load cell connected to any connected device.

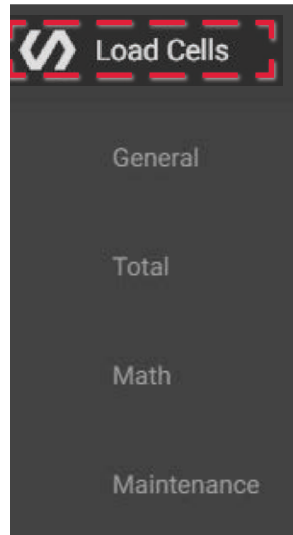

Figure 3-13. Load Cell Menu

Option	Description
General	General individual load cell configuration settings Section 3.5.1 on page 27
Total	Totaling configuration settings Section 3.5.2 on page 28
Math	Math expression configuration Section 3.5.3 on page 29
Maintenance	Load thresholds and a record of load information Section 3.5.4 on page 30

Table 3-9. Load Cell Menu Options

3.5.1 General

1. Select **Load Cells** to expand the Load Cell menu [Section 3.5 on page 26](#).
2. Select **General**.
3. Confirm device from drop down menu in upper hand corner of screen.

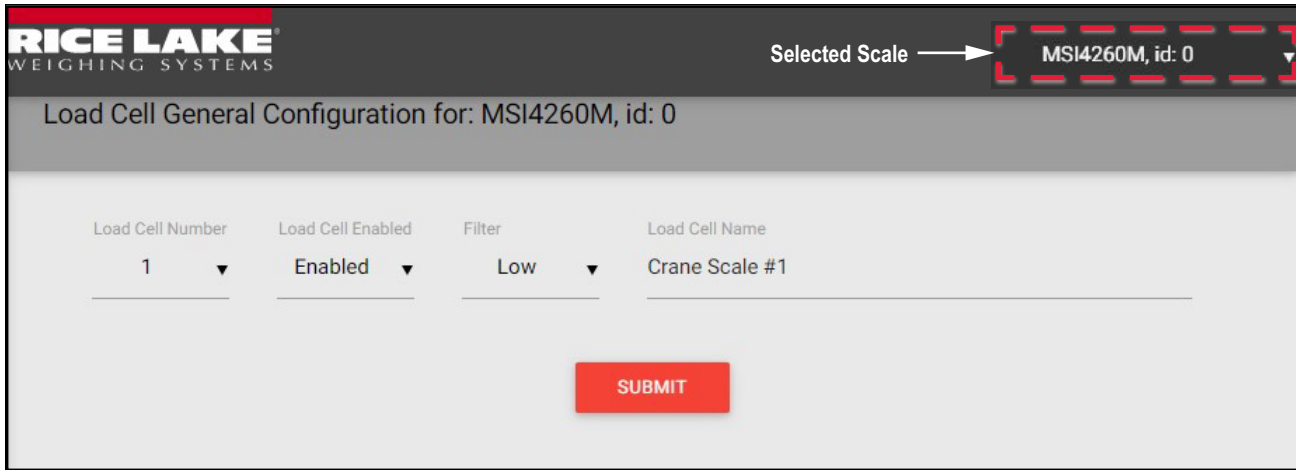

Figure 3-14. Load Cell General Configuration Screen

4. Make any necessary changes in the following parameters:

Parameter	Description
Load Cell Number	Select a load cell number 1–5
Load Cell Enabled	Select Enabled (default) or Disabled
Filter	Set filtering to Off, Low, Medium or High
Load Cell Name	Enter a name to identify the load cell

Table 3-10. Load Cell General Settings Parameters



NOTE: Crane scales and dynamometers have their own built-in load cell. Enabling additional load cell channels in a crane scale or dynamometer will have no effect on the product operation. Do not enable additional load cells for crane scales or dynamometers.



IMPORTANT: All changes to Load Cell parameters affect scale operation. Load Cell parameters must only be changed by qualified personnel.

5. Press  to save.

3.5.2 Total

1. Select **Load Cells** to expand the Load Cell menu [Section 3.5 on page 26](#).
2. Select **Total**.
3. Confirm device from drop down menu in upper hand corner of screen.

RICE LAKE
WEIGHING SYSTEMS

Selected Scale → MSI4260M, id: 0

Load Cell Total Configuration for: MSI4260M, id: 0

Load Cell Number: 1
Total Mode: Disabled
Minimum Stable Time in 50 mill Sec: 0

Lower Bound Weight Accept: 0
Upper Bound Weight Accept: 2000

The following are in Percentage of Capacity. For Example, 20, means 20% of Capacity.

Drop Threshold: 0
Rise Threshold: 1

SUBMIT

Figure 3-15. Load Cell Total Configuration

4. Make any necessary changes in the following parameters:

Parameter	Description
Load Cell Number	Select the load cell number from 1–5
Total Mode	Select the type of total mode for the connected product <ul style="list-style-type: none"> • Disabled • Auto Load • Auto Normal • Auto Peak • Load Drop • On Accept • On Command
Minimum Stable Time	Select the minimum stable time from 0–255 (in 50 ms)
Lower Bound Weight Accept	Enter the lower bound weight
Upper Bound Weight Accept	Enter the upper bound weight
Drop Threshold	Select the drop threshold number from 0–100 (in percentage of capacity)
Rise Threshold	Select the rise threshold number from 0–100 (in percentage of capacity)

Table 3-11. Load Cell Total Settings Parameters



NOTE: Crane scales only have 1 load cell. All other load cells should be disabled.

5. Press **SUBMIT** to save.

3.5.3 Math

1. Select **Load Cells** to expand the Load Cell menu [Section 3.5 on page 26](#).
2. Select **Math**.
3. Confirm device from drop down menu in upper hand corner of screen.

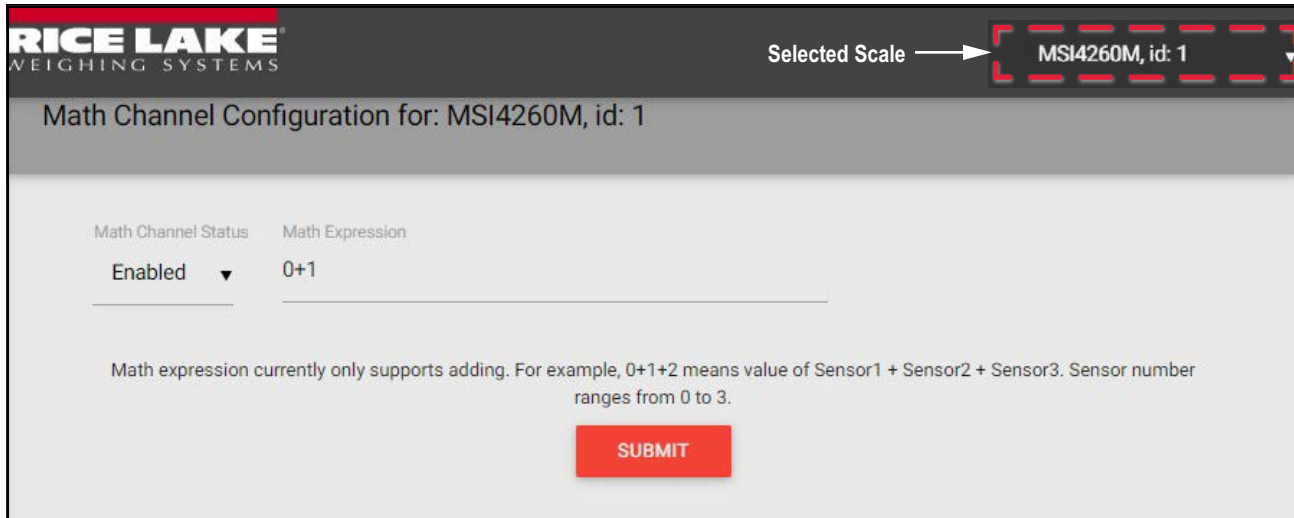

Figure 3-16. Math Channel Configuration

4. Make any necessary changes in the following parameters:

Parameter	Description
Enabled	Select Enabled or Disabled
Math Expression	Enter math expression

Table 3-12. Math Channel Settings Parameters

5. Press **SUBMIT** to save.

3.5.4 Maintenance

! **IMPORTANT:** Do not change these settings without consulting Rice Lake Weighing Systems or a local dealer.

1. Select **Load Cells** to expand the Load Cell menu [Section 3.5 on page 26](#).
2. Select **Maintenance**.
3. Confirm device from drop down menu in upper hand corner of screen.

The screenshot displays the 'Load Cell Maintenance' interface for a scale identified as 'MSI4260M, id: 1'. At the top, the 'RICE LAKE WEIGHING SYSTEMS' logo is on the left, and the 'Selected Scale' dropdown menu is on the right, showing 'MSI4260M, id: 1'. Below the header, the title 'Load Cell Maintenance for: MSI4260M, id: 1' is centered. The main area contains a 'Load Cell Number' dropdown menu set to '1'. Below this, the 'Lift Count' is 13 and the 'Overload Count' is 1. A note states 'Threshold as Percentage of Capacity. 0=0.5%, 1=1%, 100=100%'. There are two input fields: 'Lift Threshold' set to 5 and 'Drop Threshold' set to 1. A red 'SUBMIT' button is positioned at the bottom center of the form.

Figure 3-17. Load Cell Maintenance Screen

4. Make any necessary changes in the following parameters:

Parameter	Description
Load Cell Number	Select the load cell number from 1–4
Lift Count	Number of times the load cell has exceeded the Lift Threshold
Overload Count	Number of times the load cell has exceeded capacity
Lift Threshold	Select the lift threshold number from 0–100 (in percentage of capacity, 0=0.5%, 1=1%, 100=100%)
Drop Threshold	Select the drop threshold number from 0–100 (in percentage of capacity, 0=0.5%, 1=1%, 100=100%)

Table 3-13. Maintenance Settings Parameters

5. Press  to save.

3.6 Inputs / Outputs

Allows Input and Output parameters to be set for each load cell connected to any connected device.

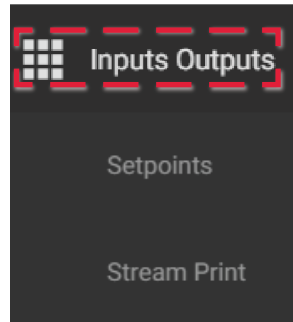

Figure 3-18. Inputs Outputs Menu

Option	Description
Setpoints	Provides trip points for load values Section 3.6.1 on page 32
Total	Provides output settings for streaming and printing Section 3.5.2 on page 28

Table 3-14. Load Cell Menu Options

3.6.1 Setpoints

Provides a trip point for load values.



WARNING: Safety systems with relay outputs for overload projection should utilize local relay outputs from load cell devices. Remote relays can be used, but will lose functionality in the event that the Scalecore Webserver loses power or communication with remote devices"

1. Select **Inputs Outputs** to expand the Input/Output Menu [Figure 3-18 on page 31](#).
2. Select **Setpoints**.
3. Confirm device from drop down menu in upper hand corner of screen.

The screenshot shows the 'Setpoint Configuration for: MSI4260M, id: 1' screen. At the top right, 'Selected Scale' points to a dropdown menu showing 'MSI4260M, id: 1'. The main configuration area includes:

- Setpoint Number:** 1
- Status:** Disabled
- Source Sensor ID:** 0
- Relay Output Mode:** Coil
- Comparison Logic:** Greater than
- Comparison Value:** 0
- Value Type:** Net Gross
- Hysteresis in D:** 3

A red **SUBMIT** button is located at the bottom center of the configuration area.

Figure 3-19. Setpoint Configuration Screen

4. Make any necessary changes in the following parameters:

Parameter	Description
Setpoint Number	Select the setpoint number from 1–3
Status	Select Disabled or Enabled
Source Sensor ID	Select the source sensor ID number from 1–5
Relay Output Mode	Select Coil or Latch
Comparison Logic	Select Undefined, Greater Than or Less Than
Comparison Value	Enter the comparison value
Value Type	Select the value type parameter
Hysteresis in D	Select the hysteresis in D number from 0–99

Table 3-15. Setpoints Configuration Parameters

5. Press **SUBMIT** to save.

3.6.2 Stream Print String



NOTE: Do not change these settings without consulting Rice Lake Weighing Systems or a local dealer.

Listeners

The Listeners feature controls the machine to machine communications interfaces.

1. Select **Inputs Outputs** to expand the Input/Output Menu [Figure 3-18 on page 31](#).
2. Select **Stream Print String**.
3. Confirm device from drop down menu in upper hand corner of screen.

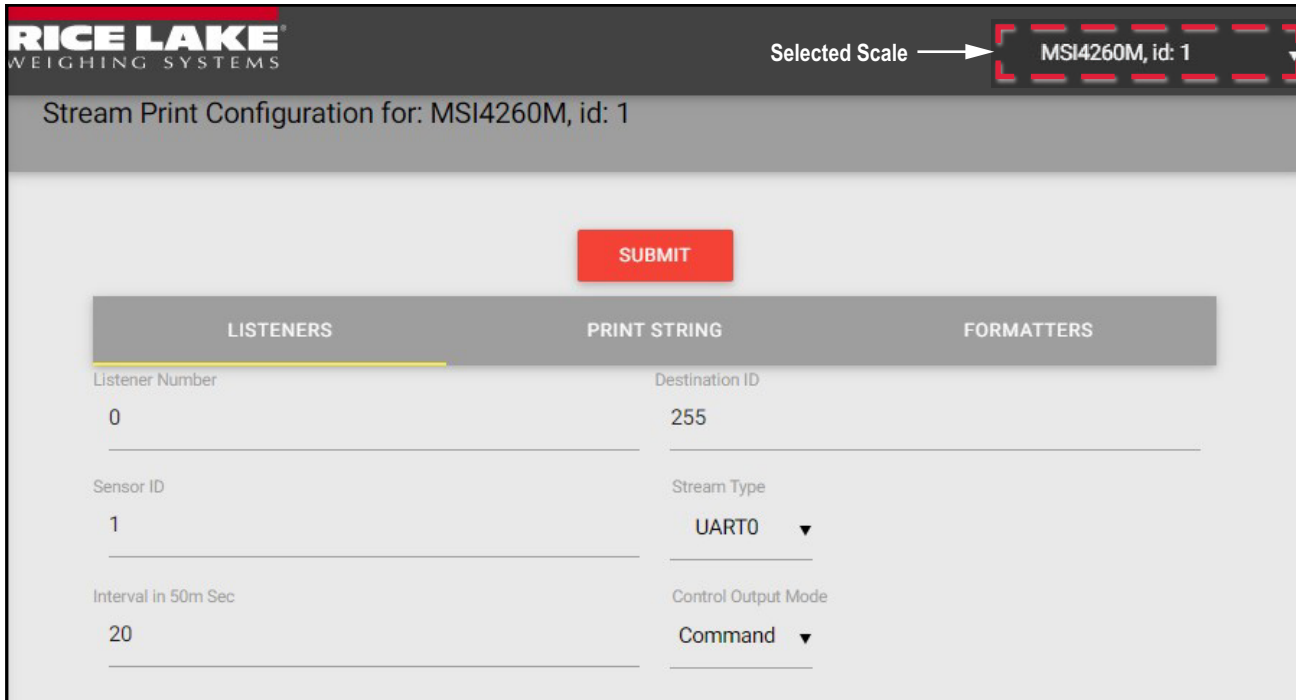

Figure 3-20. Listeners Screen

4. Select the **Listeners** tab.
5. Make any necessary changes in the following parameters:

Parameter	Description
Listener Number	Select stream listener number from 0–2
Destination ID	Select the ID assigned to the stream listener from 0–255; 255 indicates broadcast ID, it is for every device that attached
Sensor ID	Select the sensor the listener will observe from 1–5
Stream Type	Select the type of this stream listener
Interval (50 ms)	Select interval value from 0–255 Example: 20 means 20x50 ms = 1 second.
Control Output Mode	Select the mode for the listener

Table 3-16. Listener Parameters

6. Press **SUBMIT** to save.

Print String

The edit print string, allows the mode, interval and composite for a listener to be configured. The mode can be configured to print on command, on stable load, continuous, or it can be disabled. Print provides information provided by the configured print formatters in a single print.

1. Select **Inputs Outputs** to expand the Input/Output Menu [Figure 3-18 on page 31](#).
2. Select **Stream Print String**.
3. Select the **Print String** tab.
4. Confirm device from drop down menu in upper hand corner of screen.

The screenshot shows the 'Stream Print Configuration' interface for a scale identified as 'MSI4260M, id: 1'. At the top, there is a 'Selected Scale' dropdown menu. Below this, a red 'SUBMIT' button is centered. The main configuration area is divided into three tabs: 'LISTENERS', 'PRINT STRING' (which is active and highlighted with a yellow underline), and 'FORMATTERS'. Under the 'PRINT STRING' tab, there are four input fields: 'Listener Number' with the value '0', 'Control Output Mode' with a dropdown menu showing 'Command', 'Interval in Second' with the value '2', and 'Composite Formatters' with the value '1'.

Figure 3-21. Print String Screen

5. Make any necessary changes in the following parameters:

Parameter	Description
Listener Number	Select stream listener number from 0–2
Control Output Mode	Select the output mode for the print string; Disabled, Command, Stable Load, Continuous
Interval in Seconds	Select the interval period on continuous output from 0–255, 0 (fastest) up to 255 seconds
Composite Formatters	Add formatters from list; preview as needed; Clear to reset selected formatters

Table 3-17. Print String Parameters

6. Press **SUBMIT** to save.

Formatters

Displays a list of formatters.

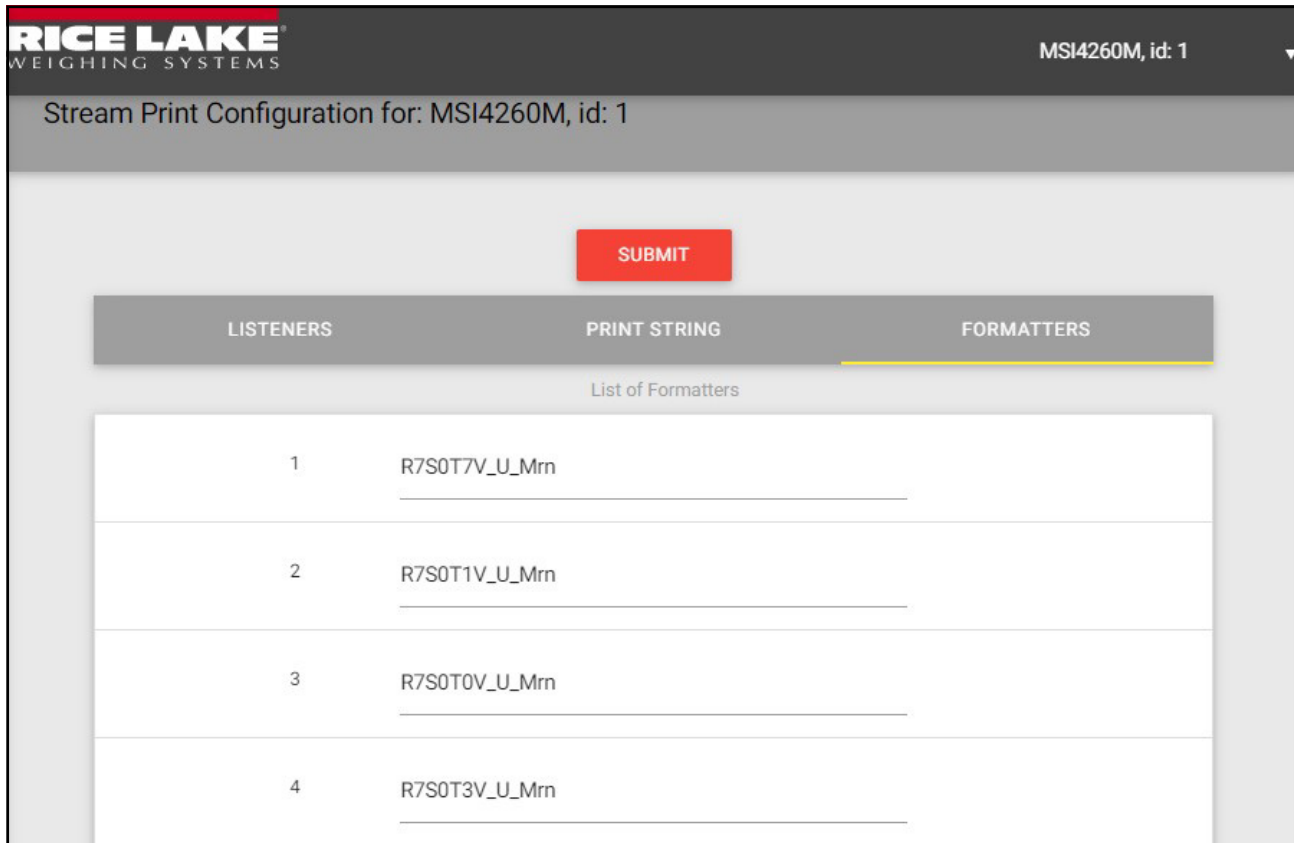

Figure 3-22. Formatters Screen

A print string formatter has 3 main types of characters. **Parameter Source** print characters control the basic structure of the print string, where the data information will be extracted from, and the type of data that will output. **Output** print characters control the type of information that is output in a print string. **Formatting** print characters control non-data related actions such as spaces and line breaks.



NOTE: All characters are case sensitive.

Character	Definition	Explanation
R##	Right justify length of next field	R5 means next item maximum width is 5 characters with padding leading spaces if needed; R0 means variable width without justify; It is only valid for one next field; ## maximum value is 12.
L##	Left justify length of next field	L5 means next item maximum width is 5 characters with padding trailing spaces if needed; L0 means variable width without justify. It is only valid for one next field. ## maximum value is 12.
S##	Defines sensor for fields V, I, M, N and U	S05 means that fields V, I, M, N and U will output values from sensor 05; Once S## is specified, following V, I, M, N and U fields are referred to current S## until new S## is specified; ## maximum value is 15. NOTE: If sensor is not specified, default sensor is Sensor#0
T#	Defines data type	# represents the type of data that trailing characters will output: 0==GROSS, 1==NET, 2==TOTAL, 3==TARE, 4==ZERO, 5==PEAK, 6==ADC COUNT, 7==CURRENT MODE. 8 == Total count Example, T1 means following value field is for NET weight value; NOTE: If data type is not specified, default type is GROSS

Table 3-18. Parameter Print Characters

Character	Definition	Explanation
V	Outputs real value	Output value is based on leading print string data type T# from sensor ID field S##;
I	Outputs integer value	Output precision is based on configured count-by d;
A	Outputs absolute value	See Table 3-18 on page 35
M	5-character string of specified data type	Output character field representing data type T#; character field is fixed at five characters with trailing padding spaces if needed; Example, T1 is NET mode; M field will print NET with two trailing blank characters T6 is ADC COUNT; M field will print ADC C with no trailing blank characters
m	First character of specified data type	Output character field representing data type T#; character field is fixed at one character; Example, T1 is NET mode; m field will print N T6 is ADC COUNT; m field will print A
N	Name of sensor	Output name of sensor S##; Name is defined by NOTE: Field can be controlled by R## and L##
U	2-character string of current unit of specified sensor	Unit output is always two characters; kg=kilogram, lb=Pound, T =Metric Ton, TN=English Ton
u	First character of current unit of specified sensor	Unit output is always one character
P	Polarity of specified sensor	Output '-' if negative; Output blank space if positive
t	Status of specified sensor	Output M= in-motion, Z=COZ, O=overload or underload; Blank space outputs if none
d#	Outputs date	# represents the date formatting: 0==yyyymmdd, 1==dd/mm/yy, 2==mm/dd/yy, 3==dd/mm/yyyy, 4==mm/dd/yyyy, 5==yyyy/mm/dd NOTE: Date can only be set on ScaleCore products that have internal clock circuitry and software.
h#	Outputs time	# represents the time formatting: 0==hhmmss, 1==hh:mm, 2==hh:mm:ss, 3==hh:mm AM/PM, 4==hh:mm:ss AM/PM NOTE: Time can only be set on ScaleCore products that have internal clock circuitry and software.

Table 3-18. Parameter Print Characters (Continued)

Character	Formatting
_	Space character
r	Carriage return
n	New line feed
^	String quote (^ABC D^ outputs "ABC D")
s	Start of text (STX)

Table 3-19. Formatting Print Characters

Examples:

String: R7S0T0V_U_Mrn

R7 - Right justify next output with 7 characters width

S0 - All values extracted from Sensor 0

T0 - All data extracted as GROSS mode

V - Output data value precision based on count-by

_ - Space

U - Output 2-character string unit

_ - Space

M - Output 5-character data type string

r - carriage return

n - line feed

Output: **12345 lb GROSS** <cr LF>

String: S0T0MR7V_Urn

Output: **GROSS 12345 lb** <cr LF>

String: S0R4NT0R7V_U_Mrn

Sensor name is "WestSide." Print string only outputs "West" because R4 limits the N output to 4 characters.

Output: **West 12345 lb GROSS** <cr LF>

String: ^Crane:1 ^S0T0R7V_U_Mrn

1st field is a string "Crane:1".

Output: **"Crane:1" 12345 lb GROSS** <cr LF>

Standard Rice Lake Serial Scale String: sPR7S0T7Aumtrn

3.7 Network

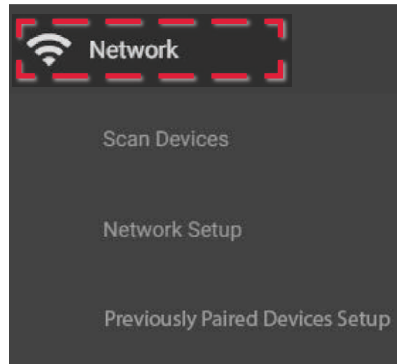

Figure 3-23. Inputs Outputs Menu

Option	Description
Scan Devices	Manually scan for new devices Section 3.7.1 on page 38
Network Setup	Provides network configuration settings Section 3.7.2 on page 39
Previously Paired Devices Setup	Enable and delete devices that are permanently part of the network Section 3.7.3 on page 40

Table 3-20. Load Cell Menu Options



IMPORTANT: Changing the Network Configuration settings may result in loss of connection to scales and displays. Wi-Fi Network settings for scales, indicators, and displays are not user configurable and may only be reset by Rice Lake Weighing Systems.

3.7.1 Scan Devices

Use Scan Devices to update the list of available scales when new scales that are not in the Previously Paired list are added. If there are available scales that do not display, run a server scan.

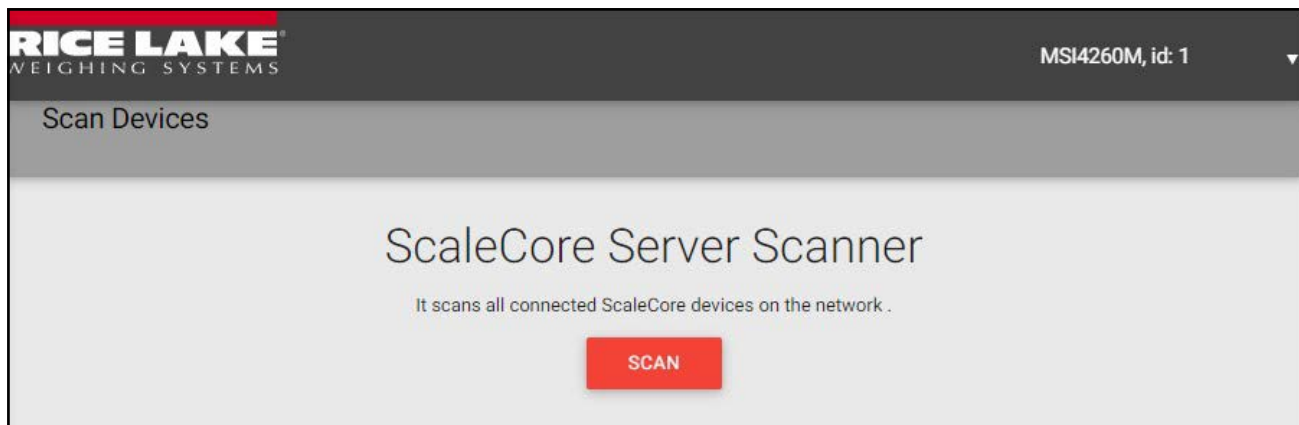

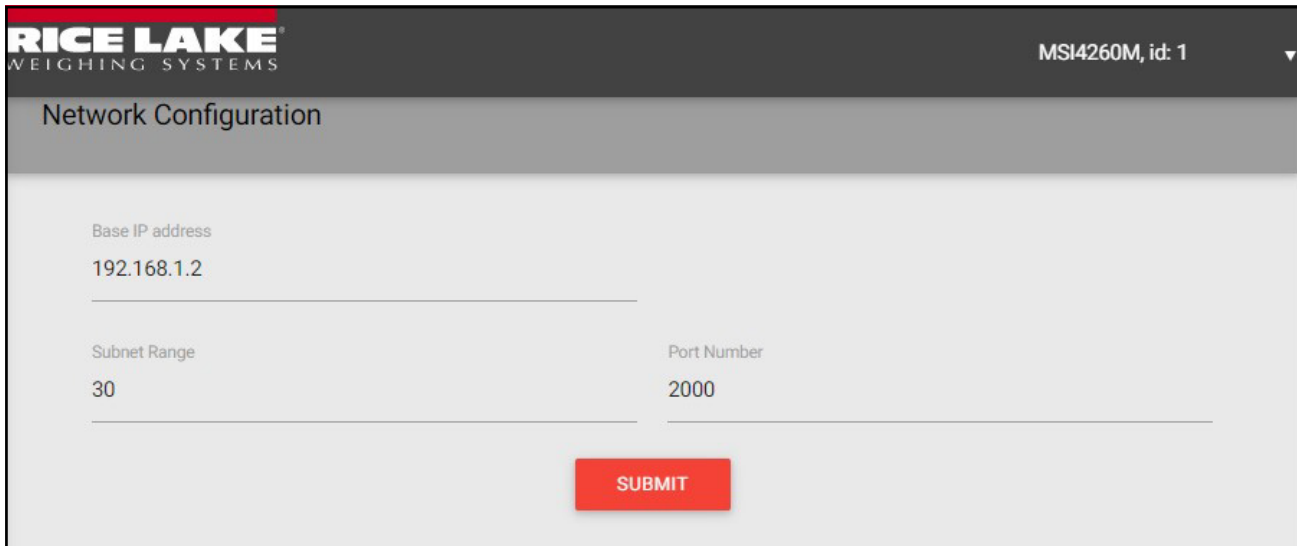

Figure 3-24. ScaleCore Server Scanner

3.7.2 Network Setup

Select Scan to scan for ScaleCore devices connected to the network.

 **NOTE:** Only administrator level users have access to Network Setup.



The screenshot shows a web browser window with the Rice Lake Weighing Systems logo in the top left and the user identifier 'MSI4260M, id: 1' in the top right. The page title is 'Network Configuration'. The form contains three input fields: 'Base IP address' with the value '192.168.1.2', 'Subnet Range' with the value '30', and 'Port Number' with the value '2000'. A red 'SUBMIT' button is centered below the fields.

Figure 3-25. ScaleCore Webserver Scanner

Subnet range will work in conjunction with the base IP address. For example, if the base IP address is 192.168.1.2 and the Subnet range is 30, the web server will search for devices with IP addresses between 192.168.1.2 and 192.168.1.32.

 **NOTE:** The subnet should be limited to cover only the address range being used by the network. A larger number increases Scan Device time both manually and at every power-up.

3.7.3 Previously Paired Devices Setup

The ScaleCore Webserver adds all devices to the Previously Paired Devices Setup list when they are first detected during a scan for devices, either manually or automatically on power up. The Previously Paired Devices list includes all indicators, scales or remote devices. If an enabled device is disconnected from the network or powered off, the ScaleCore Webserver continuously attempts to reconnect with the device. Devices are included on the Previously Paired Devices list until they are disabled or deleted by an admin level user.

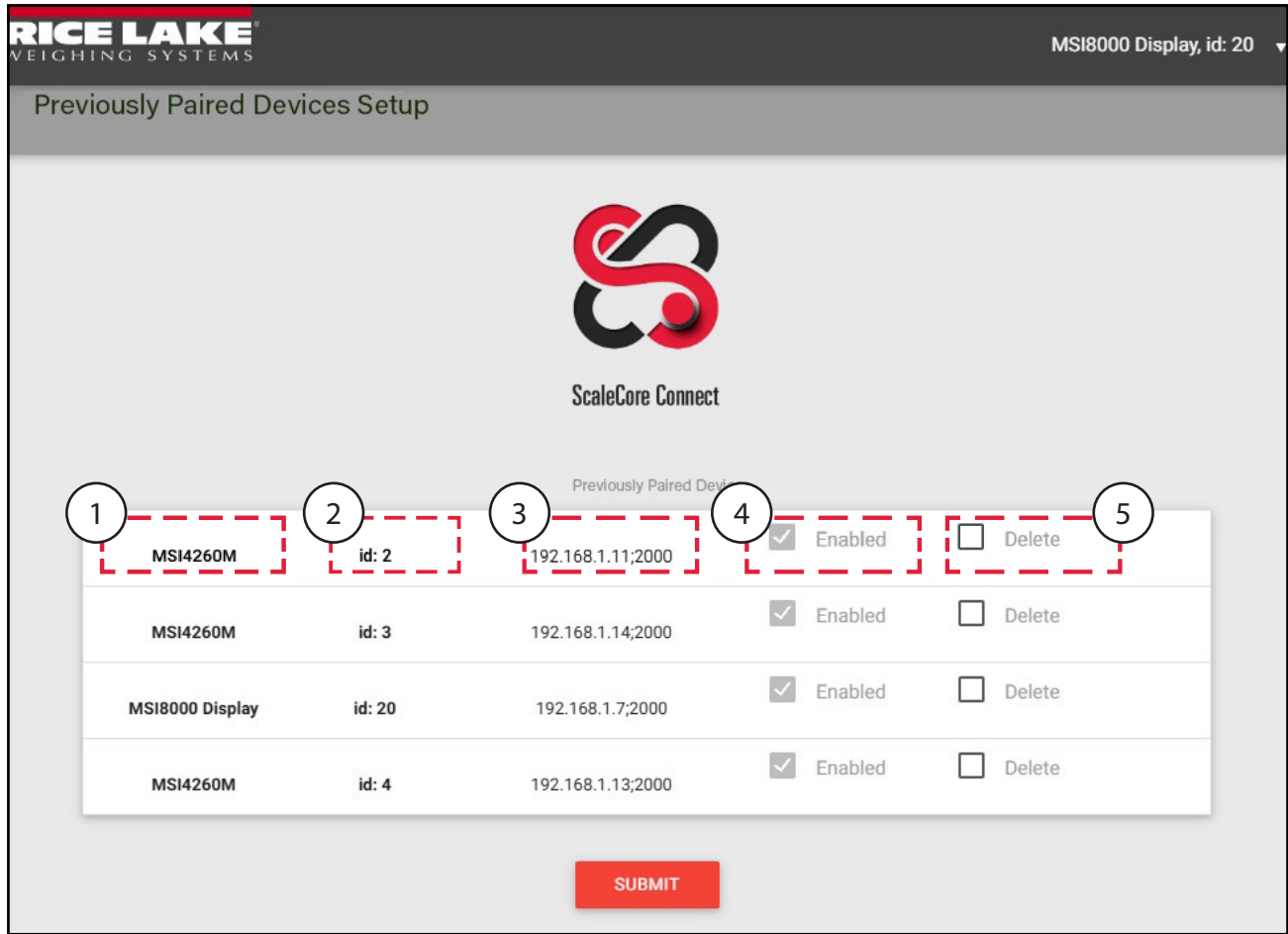

Figure 3-26. ScaleCore Webserver Scanner

Number	Parameter	Description
1	Device Model Name	Model name of persistently connected device
2	Device ID	Assigned identification number
3	Device IP Address	Device static IP address
4	Enabled	Toggled ON <ul style="list-style-type: none"> If device is powered on and in range, ScaleCore Webserver maintains connection with the enabled device. If device is not on or is not in range, ScaleCore Webserver continuously attempts to connect with the device. Toggled OFF <ul style="list-style-type: none"> ScaleCore Webserver disconnects from device and does not attempt to reconnect.
5	Delete	Toggle Delete ON and select SUBMIT to remove ScaleCore Webserver from the previously paired device list permanently.

Table 3-21. Maintenance Settings Parameters

3.8 User Group

User group allows the viewing and setup of users and user privileges. User privilege selections are Viewing, Scale User, Limited Admin and Admin (Table 3-22 on page 41). The User Group Network Configuration screen is only available if the user is signed in as Admin.

To switch users, close the current window and reopen and log into another.

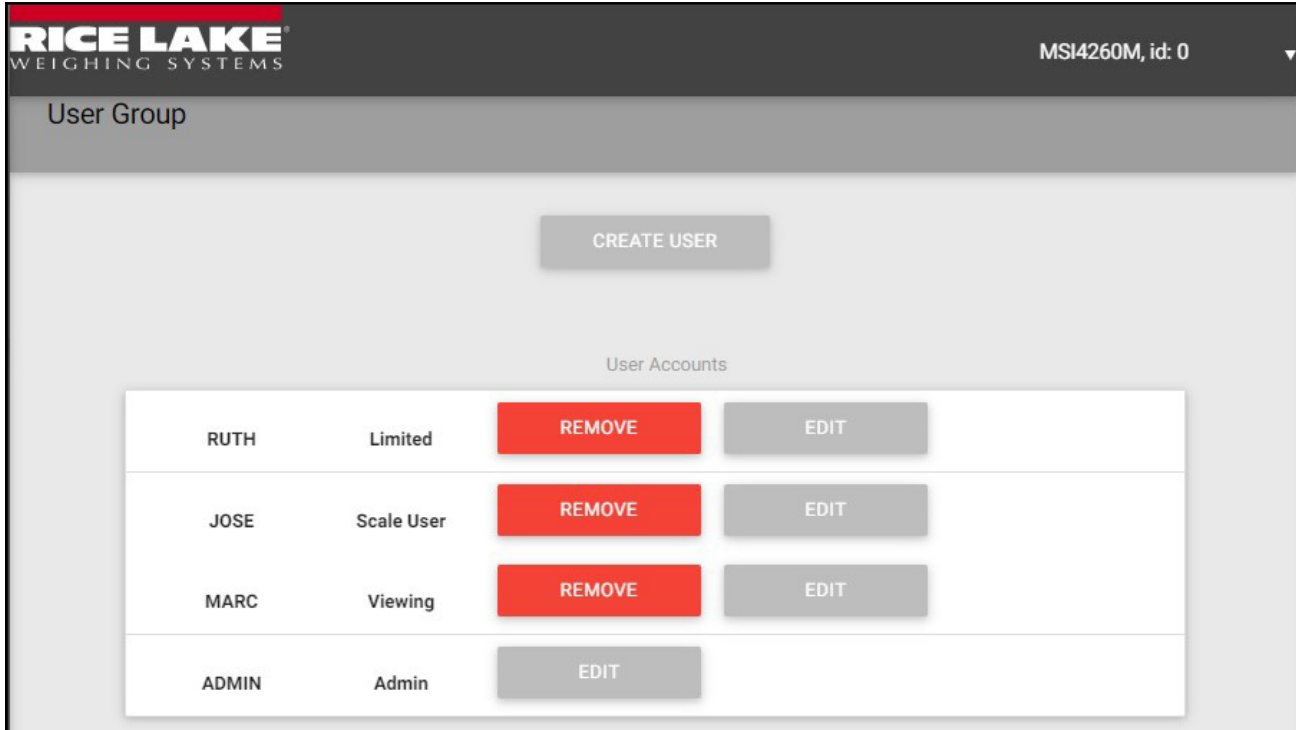

Figure 3-27. User Group Screen

New users can be assigned one of four user privilege levels. See Table 3-22. for capabilities of each user privilege level.

	Admin	Limited Admin	Scale User	Viewing
Monitors				
Indicator	Y	Y	Y*	Y**
Multi Indicator	Y	Y	Y*	Y**
User Sum	Y	Y	Y*	Y**
Configuration				
Product Info	Y	Y	N	N
DAC Configuration	Y	Y	N	N
RF Configuration	Y	Y	N	N
Meter Features	Y	Y	N	N
Scan Lists	Y	Y	N	N
Date Time	Y	Y	N	N
Load Cells				
General	Y	Y	N	N
Total	Y	Y	N	N
Math	Y	Y	N	N
Maintenance	Y	Y	N	N

Table 3-22. ScaleCore Webservice Permissions

	Admin	Limited Admin	Scale User	Viewing
Inputs/Outputs				
Setpoints	Y	Y	N	N
Stream Print String	Y	Y	N	N
Network				
Scan Devices	Y	Y	N	N
Network Setup	Y	Y	N	N
Previously Paired Device Setup	Y	Y	N	N
User Group	Y	N	N	N

Table 3-22. ScaleCore Webserver Permissions

* **Scale User** can control scale functions, such as zero and tare.

****Viewing** is read-only and is not able to configure or control the scale. **Viewing** can be used to set an account that allows for a customer to view live weight without affecting the scale operation.

3.8.1 Create User

To create a new user:

1. Select **User Group** to display User Accounts.
2. Select **Create User**. New user dialog box displays.

The screenshot shows a 'New User Dialog' form. At the top left, it says 'New User Name' and 'Password length must greater than 4 characters'. Below this, there is a text input field containing 'TestUserName'. To the right of this field is a password input field, also masked with dots. Below the password field is a 'Privilege Level' dropdown menu currently set to 'Viewing'. At the bottom right of the form are two buttons: a red 'SUBMIT' button and a grey 'CANCEL' button.

Figure 3-28. New User Dialog

3. Enter **New User Name**, **Password** and **Privilege Level** (Table 3-22.).
4. **Confirm Password** by re-entering password.
5. Select **Submit**. New user displays on the User Group screen.
6. Select **Yes**.

3.8.2 Edit User

To edit an existing user:

1. Select **User Group** to display User Accounts.
2. Select **Edit** to the right of the user to be edited (Figure 3-27 on page 41).

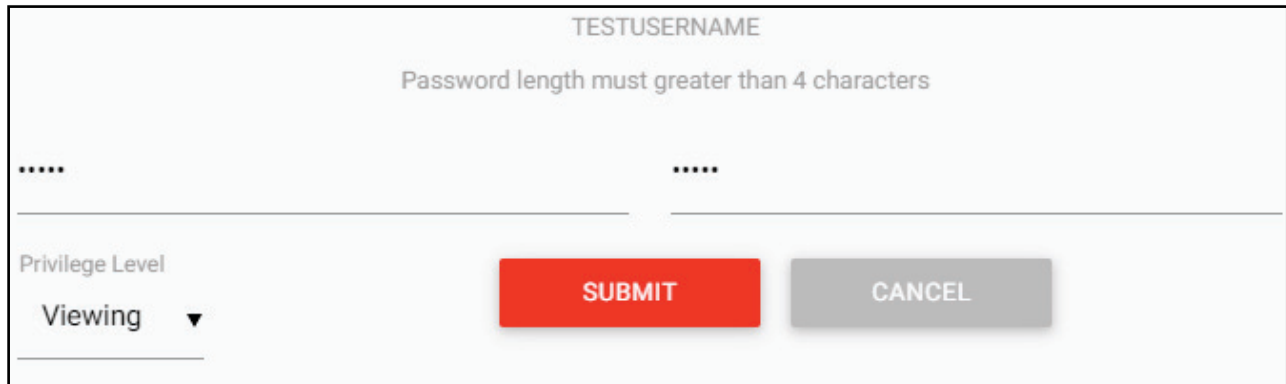

Figure 3-29. Edit User Dialog

3. **Password** and **Privilege Level** (Table 3-22 on page 41).
4. **Confirm Password** by re-entering password.
5. Select **Submit**.

3.8.3 Remove User

To remove an existing user:

1. Select **User Group** to display User Accounts.
2. Select **Remove** to the right of the user to be removed (Figure 3-27 on page 41). Confirmation box displays.

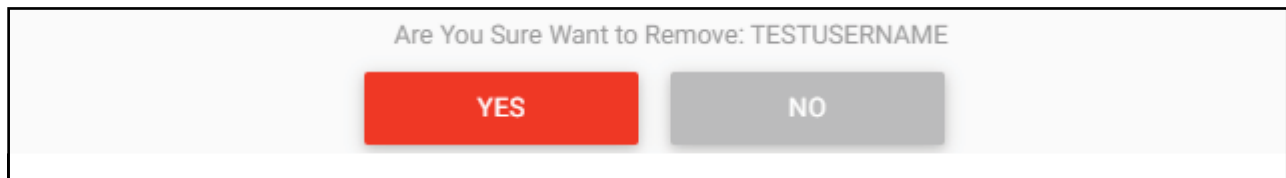

Figure 3-30. Remove User Confirmation Box

4.0 Advanced Setup

4.1 Troubleshooting

This is a good spot for troubleshooting info

4.2 Antenna Options



NOTE: To meet FCC licensing rules, use only antennas supplied or recommended by Rice Lake Weighing Systems.

Antenna placement is critical to problem-free use of the system.

- Ensure a relatively clear transmission path exists between the devices to be connected; Radio signals travel primarily by line of sight (LOS), obstructions between stations may degrade the system performance
- When using the long range antenna, mount the antenna on an elevated structure to ensure that you have a clear LOS transmission path; This will ensure the antenna will clear surrounding obstructions; Do not provide a ground plane for the antenna
- Fixed station locations often benefit from directional antennas when the location of the other components of the RF network are fixed and/or in the same direction; Never use a directional antenna on a mobile system
- If using the standard antenna, ensure the antenna is not blocked by any metal; Transmission is good through most kinds of glass so mounting a meter next to a window will work fine; If there is no clear line of sight place to mount the receiving device, consider switching to the long range antenna so the antenna can be set up remotely
- The standard and long range antennas are vertical plane devices; They should be vertical, pointing up or down, when high off the ground (like the underside of a large bridge crane); Do not mount them sideways; The long range 9 dBi antenna is particularly sensitive to off axis mounting; Use a level to ensure the antenna is exactly 90° perpendicular to the earth
- Do not mount an omni-directional antenna next to metallic or concrete surfaces; This can result in reflections and undesired RF characteristics; Use a corner reflector instead
- After installation, seal the antenna connection with an adhesive heat shrink boot; Failure to seal the antenna may result in liquid destroying the antenna and device it's connected to



NOTE: Rice Lake Weighing Systems does not generally recommend extending coaxial cable beyond three meters. There are cases where the signal loss from a longer cable is less than the signal improvement from moving the antenna to a better location. Please consult Rice Lake Weighing Systems if use of a longer coaxial cable is required.

Standard Antenna

The standard antenna is an articulated 1/2 wave 2 dBi gain design with a reverse TNC connector that mounts directly on the enclosure.

This antenna and coax connector, though resistant to water, is not water-proof. Seal the reverse TNC base with an adhesive heat shrink boot if this antenna might be exposed to rain or other weather conditions where it could get wet.

This antenna must be vertically oriented and is suitable for most short to medium range applications.



4.3 Server Updates

The ScaleCore Webserver is easily upgraded or downgraded using a USB drive. ScaleCore Webserver software updates can be found at www.ricelake.com.

1. Copy ScaleCore Webserver software .pkg file onto a USB drive.



**NOTE: USB drive must be formatted as FAT32
USB file must contain only one .pkg file.**

2. Insert USB drive into one of the USB ports. The web server automatically loads and installs software. Wait time depends on whether or not the web server is already powered up.
 - If the web server is ON, wait for about 2.5 minutes for installation.
 - If the web server was OFF, turn it on and wait for about 4.5 minutes for web server boot up and installation.
3. Clear HTML5 browser cookies.



NOTE: For optimal performance, set browser to auto-delete cookies and clear history upon browser exit. Process for clearing cookies is browser specific. Refer to help resources located in browser menu.

4. Restart HTML5 browser.
5. Remove USB drive.



IMPORTANT: If USB drive contains an older software version than what is currently installed on the ScaleCore Webserver, the software on the webserver will be downgraded to the version on the USB drive. Downgrading software may result in loss of product features, functionality or configuration data.

After updating software, repeat steps 3-5 on all web browsers that are connected to the Webserver.

If any other ScaleCore Device requires an update, refer to the device specific ScaleCore product manual for update instructions.

4.4 ScaleCore Webserver Mechanical Maintenance

The ScaleCore Webserver does not need to be opened for normal operation and should only be opened to attach a custom power cable to the power terminal block, to replace the battery for the Real Time Clock or to remove the Ethernet cable Opening

4.4.1 Open Enclosure

If the ScaleCore Webserver enclosure needs to be opened, follow the instructions below:

1. Remove tamper evident stickers.
2. Remove enclosure screws and enclosure lid with phillips head screwdriver.

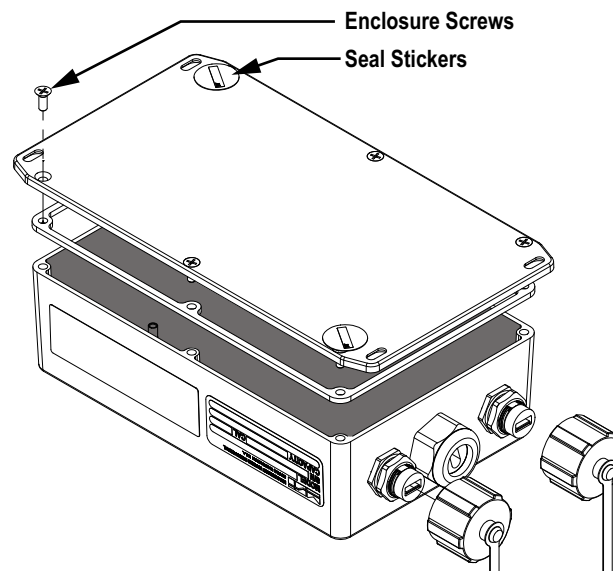

Figure 4-1. Enclosure Screw Locations

4.4.2 Reseal Enclosure

1. Align enclosure gasket with the open lip of the enclosure.
2. Replace lid of enclosure.
3. Replace enclosure screws (Figure 4-1 on page 45) with a philips head screwdriver.
4. Torque screws to 5 in-lb.

4.4.3 Cable Connections

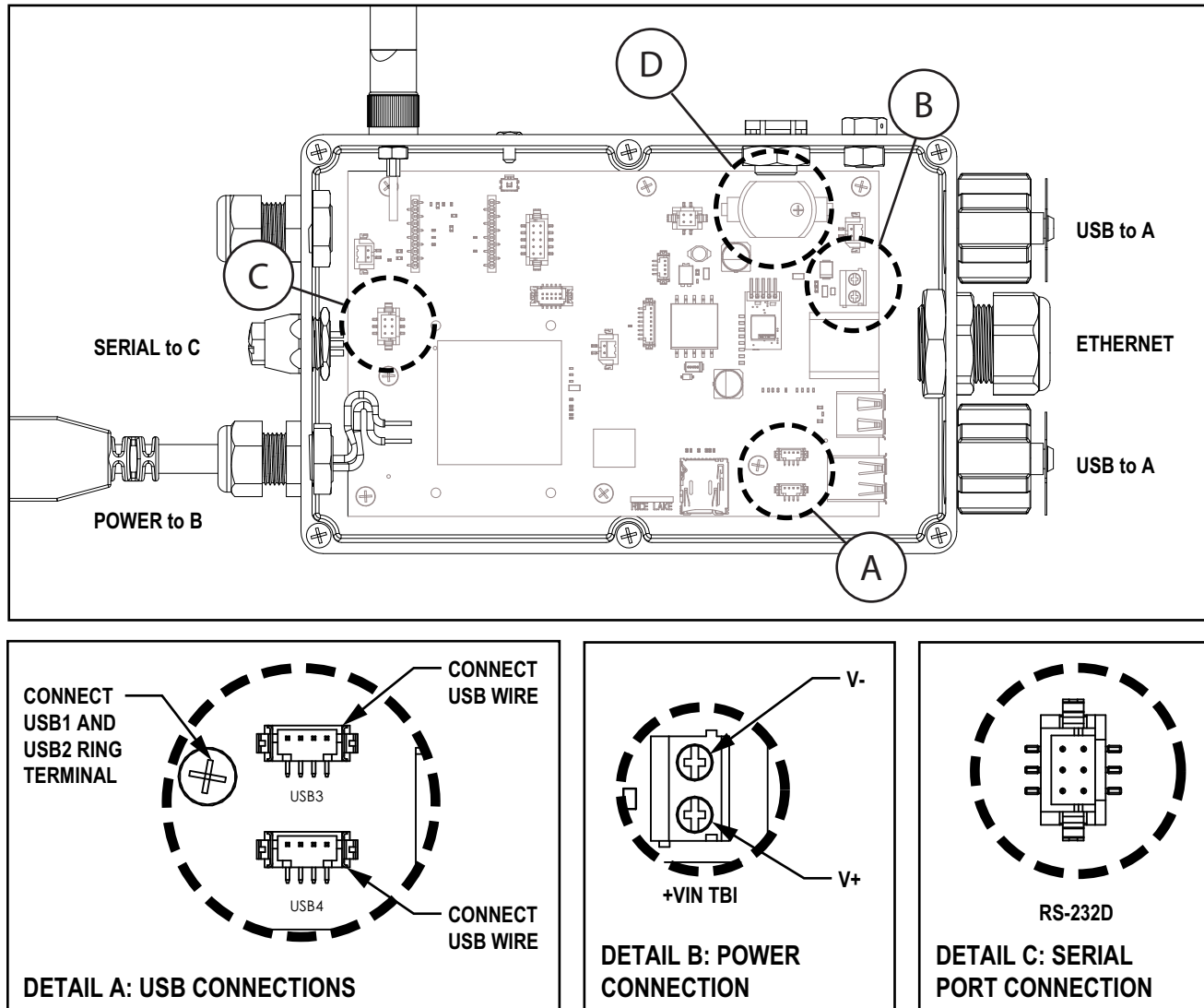

Figure 4-2. Connections

4.4.4 Replace Battery

The ScaleCore Webserver utilizes a CR2016 coin-cell battery to maintain time and date while the ScaleCore Webserver is disconnected from a power supply. If the ScaleCore Webserver no longer updates the time and date while the power is disconnected from a power supply, the battery may need to be replaced. Battery life is approximately 5 years with a fresh battery. A Phillips screwdriver and a flathead screwdriver are needed to remove the coin cell battery.



WARNING: Dispose of batteries at appropriate waste collection centers at the end of their life cycle in accordance with local laws and regulations. Batteries and rechargeable batteries may contain harmful substances that should not be disposed of in household waste. Batteries may contain harmful substances including but not limited to: cadmium (Cd), lithium (Li), mercury (Hg) or lead (Pb). Users who dispose of batteries illegally shall face administrative sanctions as provided by law.

1. Disconnect the ScaleCore Webserver from the external power source.
2. Open the enclosure. ([Section 4.4.1 on page 45](#))
3. Carefully remove the coin-cell battery from the battery holder with a small flathead screw driver.

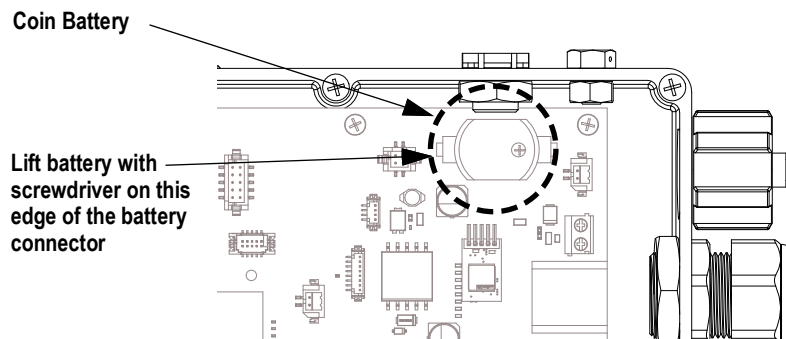

Figure 4-3. CPU Board Bottom



IMPORTANT: Attempting to directly lift the coin-cell battery without a screwdriver could result in pulling the battery holder off of the circuit board. If the battery holder is pulled off of the circuit board, the entire board must be replaced.

4. Replace the battery in the holder with the positive side facing up.
5. Reseal the Enclosure. ([Section 4.4.4 on page 47](#))

4.5 Replacement Parts

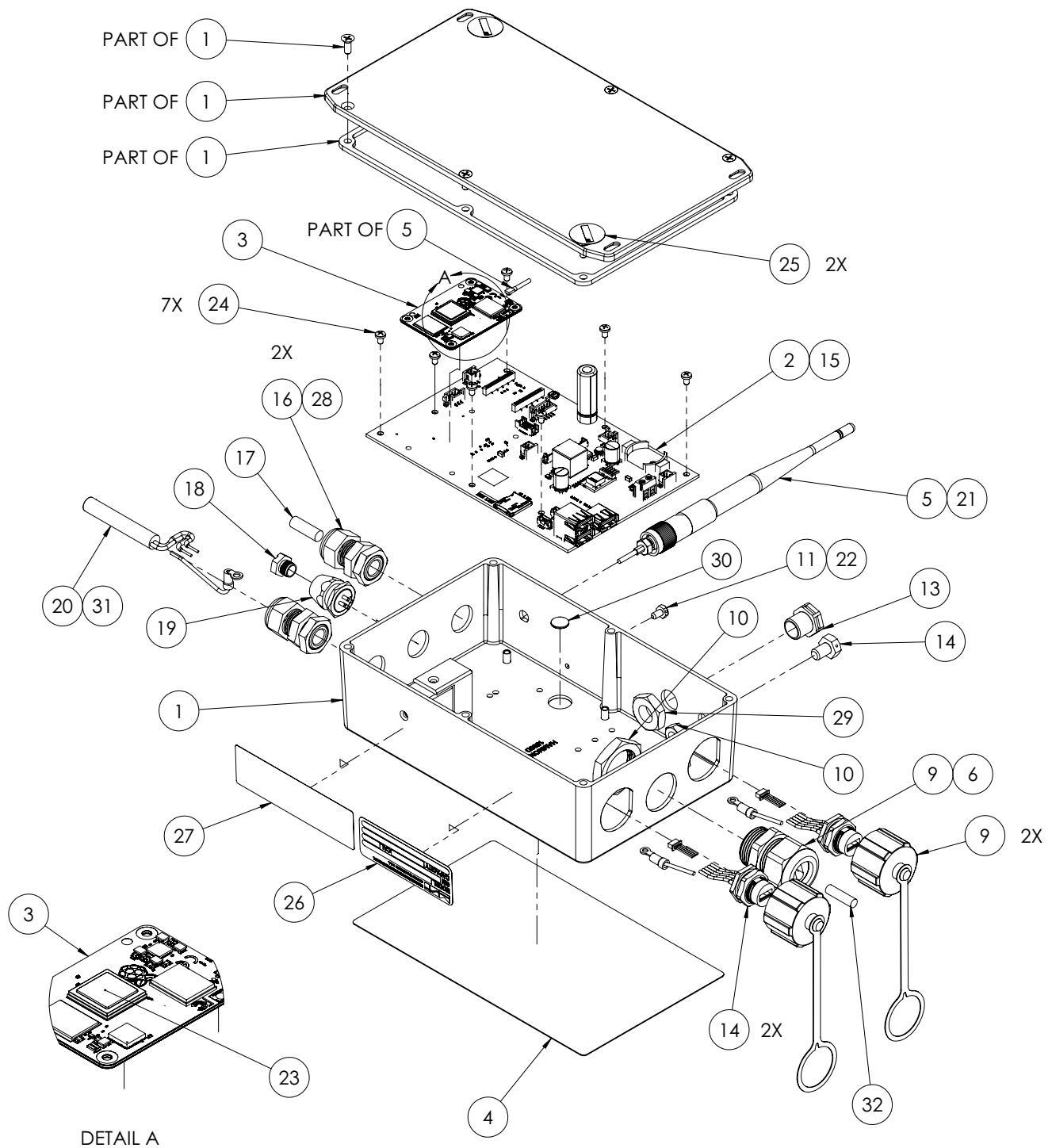

Figure 4-4. ScaleCore Webserver Replacement Parts

Replacement parts for the three ScaleCore Webserver options include all common part numbers. Unique parts for each option can be found in [Table 4-2](#), [Table 4-3](#) and [Table 4-4 on page 50](#):

Item No.	Part No.	Description	Qty
1	203681	ScaleCore Webserver, Enclosure Machined	1
2	--	Unique to each option; see Table 4-2 , Table 4-3 and Table 4-4 on page 50	1
3	208040	SoM, CM4, 4GB Ram, 32GB eMMC, Wi-Fi and Bluetooth with U.FL connector	1
4	208997	Overlay, ScaleCore Webserver	1
5	213125	Antenna, 2.4 GHz articulated with reverse TNC connector	1
6	210823	Sealcon PG16 O-ring	1
7	210821	Sealcon PG16 RJ45 Cord Grip	1
8	210822	Sealcon PG16 Lock Nut	1
9	210820	USB Waterproof Cap	2
10	14642	Nut, 1/4-20NC HEX SST	1
11	142574	SCREW, HH DR HD SS Blk 6-32 1/4	1
12	209700	Cable Assy USB 2.0	2
13	88733	Vent, Breather Sealed Goretex Membrane in black molded plastic chassis Gore IP69K rated	1
14	211031	Screw Seal 1/4-20 x .381g Hex Head SS	1
15	71408	Battery, Lithium CR2032 3 Volt for Welding Helmet, Metal	1
16	141593	Conn Feed Thru Liquid Tight Dome PG9 .16-.31 Cable Dia. W/ Nut	2
17	141991	Pin Round Acetal .25 Dia .75 LG	1
18	143352	Conn Closure Cap IP68 Male	1
19	139449	Cable Assy Comm Serial Data RS-232 4260B	1
20	--	Unique to each option; see Table 4-2 , Table 4-3 and Table 4-4 on page 50	
21	210824	ScaleCore Antenna Gasket	1
22	144645	Washer, Rubber #6 .120ID x .250D x .062 THK	1
23	211159	Pad Thermally Conductiver 15mm x 15mm 2.0mm Thick Square, Blue, Tacky both sides	1
24	142233	Screw LKG PCH MACH PNH PHH SS 4-40 3/16 LG	7
25	162882	Label, Tamper Evident	2
26	148637	SERIAL NUMBER TAG, 8000T, Void matte silver 05145RM, TTL 2.75 x 1.00 Wi-Fi	1
27	--	Unique to each option; see Table 4-2 , Table 4-3 and Table 4-4 on page 50	
28	177363	O-Ring, PG9, Buna-N 8004	2
29	88734	Nut, Breather Vent molded plastic	1
30	161540	Shim disk 3/8 x .035 w/ Adh Tact Switch Spacer	1
31	--	Unique to PN 210817 See Table 4-4 on page 50 Not included in PN 207943 or PN 209704	
32	211473	PIN ROUND ACETAL 3/16 DIA .75 LG	1

Table 4-1. ScaleCore Webserver Common Replacement Parts

Item No.	Part No.	Description	Qty
2	192023	PCA, ScaleCore Webserver, Assy, Main Board	1
20	210930	Cable Assy 5VDC Power 10 ft 7000	1
27	209613	Label, ScaleCore FCC, 5VDC	1

Table 4-2. ScaleCore Webserver, 5 VDC (PN 207943) Unique Replacement Parts

Item No.	Part No.	Description	Qty
2	203724	PCA, ScaleCore Webserver, Assy, Main Board	1
20	182076	Cable Assy 7-14VDC Power 10 ft 7000	1
27	209614	Label, ScaleCore FCC, 7-14VDC	1

Table 4-3. ScaleCore Webserver, 7-14 VDC (PN 209704) Unique Replacement Parts

Item No.	Part No.	Description	Qty
2	192023	PCA, ScaleCore Webserver, Assy, Main Board	1
20	159816	Cable w/DC Jack 15 ft TPU 2.1 DC Coaxial Power Jack	1
27	209613	Label, ScaleCore FCC, 5VDC	1
31	211450	ScaleCore Webserver A/C Power Adapter	1

Table 4-4. ScaleCore Webserver, 85-265 VAC w/ Wall Adapter (PN 210817) Unique Replacement Parts

4.6 Troubleshooting

For troubleshooting information related to the scales and weighments, refer directly to the device Technical Manual.

Problem	Possible Cause	Solution
Device does not appear on the list	Device powered off	Check that device is powered on
	Device settings don't match ScaleCore Webserver settings	Check that device network settings match ScaleCore Webserver settings
	Device not recognized in scan	Rescan the network or powercycle the Scalecore Webserver
The display does not function properly, or Front panel keys do not function normally, or Device will not turn off	Improperly loaded software	Reinstall the software
	Faulty circuit board	Requires authorized service
	Loose connectors	Requires authorized service
Devices appear to be duplicated		Wait at least 30 seconds and manually scan devices (Section 2.3 on page 14)
Weight on the device and ScaleCore Webserver do not match	Units are not paired	See setting the RF Network address procedures
Time and date do not stay updated when power is off	Coin-cell battery may be spent	Replace coin-cell battery (Section 4.4.4 on page 47)

Table 4-5. Troubleshooting Solutions

5.0 Specifications

Minimum System Requirements

Will display on any device with a web browser supporting HTML 5

Connected ScaleCore-based MSI scales and indicators are required to have the optional Wi-Fi radio module

Connectivity

Wi-Fi 2.4 GHz IEEE 802.11g

Gigabit Ethernet

2 x USB 2.0 Interface

RS-232 Serial

Status Annunciators

Units (lb, kg, short tons (tn), metric tons (t), (NONE) gross/net, motion, center of zero

Operating Temperature

-20 °C to 40 °C (-4 °F to 104 °F)

-10 °C to 40 °C (14 °F to 104 °F) **NTEP Approved**

Effective Range

Typically 100 ft to 300 ft, line of sight; for longer range consult factory

Enclosure

IP65, aluminum black powder coated

(excludes 85-265 VAC power supply)

Power

5-6 VDC

7-14 VDC

85-265 VAC, PoE

Warranty

One year limited

Approvals

NTEP CC 21-098 Classes III and IIIIL at 10,000d



© Rice Lake Weighing Systems Content subject to change without notice.

230 W. Coleman St. • Rice Lake, WI 54868 • USA USA: 800-472-6703 • International: +1-715-234-9171