

# Tracer AV2

*Aviation Weighing Solutions*

## Technical Manual

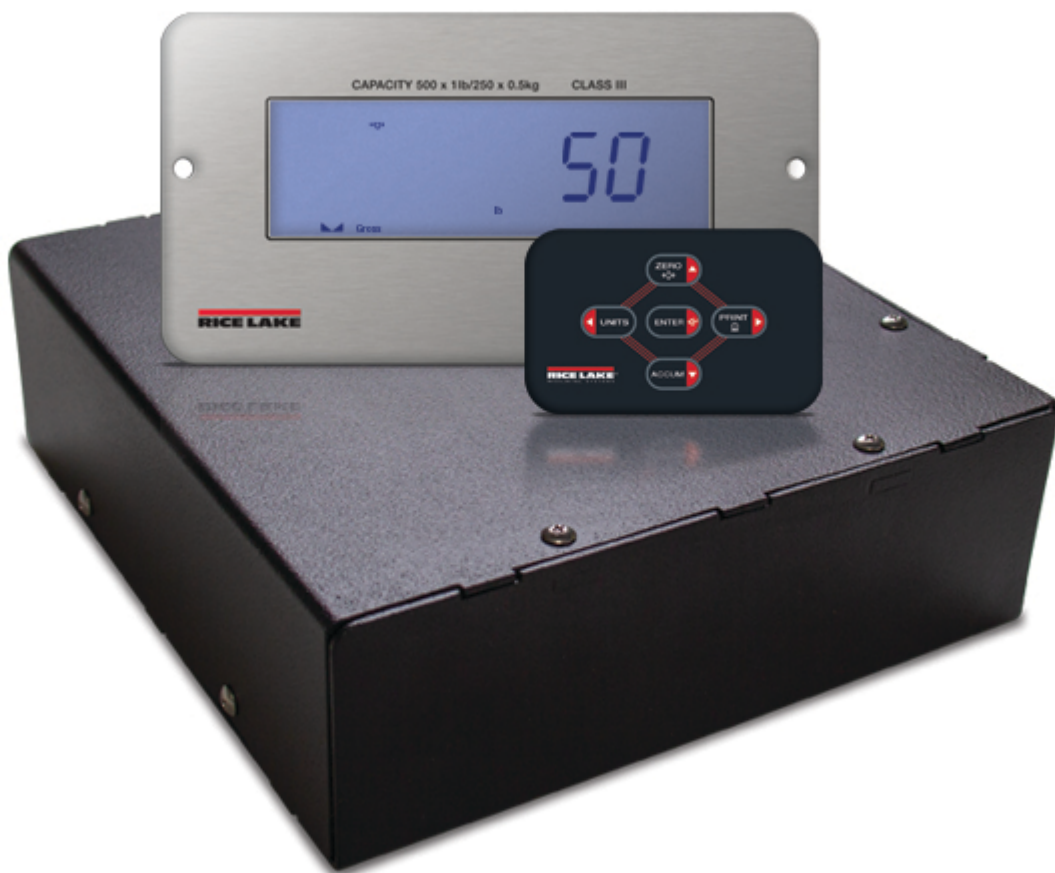

**RICE LAKE**<sup>®</sup>  
WEIGHING SYSTEMS

© Rice Lake Weighing Systems. All rights reserved.

Rice Lake Weighing Systems® is a registered trademark of  
Rice Lake Weighing Systems.

All other brand or product names within this publication are trademarks or  
registered trademarks of their respective companies.

All information contained within this publication is, to the best of our knowledge, complete and  
accurate at the time of publication. Rice Lake Weighing Systems reserves the right to make  
changes to the technology, features, specifications and design of the equipment without notice.

The most current version of this publication, software, firmware and all other product  
updates can be found on our website:

[www.ricelake.com](http://www.ricelake.com)

# Revision History

---

This section tracks and describes manual revisions for awareness of major updates.

Revision	Date	Description
C	March 10, 2023	Established revision history; updated menu access instructions; updated menu illustrations and tables; updated parameter commands
D	September 17, 2024	Updated replacement parts

*Table i. Revision Letter History*



*Technical training seminars are available through Rice Lake Weighing Systems. Course descriptions and dates can be viewed at [www.ricelake.com/training](http://www.ricelake.com/training) or obtained by calling 715-234-9171 and asking for the training department.*

# Contents

<b>1.0 Introduction</b>	<b>7</b>
1.1 Safety	7
1.2 FCC Compliance	8
1.3 Overview	8
1.4 Operating Modes	8
<b>2.0 Installation</b>	<b>9</b>
2.1 Unpacking	9
2.2 Component Dimensions	9
2.2.1 CPU Enclosure Assembly	9
2.2.2 Remote Keypad (Panel Mount)	10
2.2.3 Remote Display (Panel Mount)	11
2.2.4 Remote Display (External Mount)	12
2.3 Mounting Brackets	13
2.3.1 Bracket Assembly	13
2.3.2 Mounting Instructions	13
2.4 External Cable Connections	14
2.4.1 Load Cell Connector	14
2.4.2 Serial Connector	14
2.4.3 Remote Display Connectors	15
2.4.4 Remote Keypad Connector	15
2.5 System Illustrations	15
2.5.1 System Configuration 1	15
2.5.2 System Configuration 2	16
2.5.3 System Configuration 3	16
2.6 Interior Access	17
2.7 CPU Board	17
2.7.1 Load Cell	18
2.7.2 RS-232 Serial Communication	18
2.7.3 Remote Displays	18
2.8 Sealing the Indicator (Optional)	19
2.9 Replacement Parts	20
2.9.1 Replacement Parts List	21
2.9.2 Available Product Part Numbers	21
<b>3.0 Operation</b>	<b>22</b>
3.1 Display	22
3.1.1 LCD Annunciators	22
3.2 Remote Keypad	23
3.3 General Navigation	23
3.3.1 Numeric Value Entry	24
3.3.2 Alphanumeric Entry	24
3.4 General Operation	25
3.4.1 Zero Scale	25
3.4.2 Print Ticket	25
3.4.3 Print Accumulator Ticket	25
3.4.4 Toggle Units	25
3.4.5 View Legally Relevant Version	25



Rice Lake continually offers web-based video training on a growing selection of product-related topics at no cost. Visit [www.ricelake.com/webinars](http://www.ricelake.com/webinars)

3.4.6	View Audit Trail Counters . . . . .	26
3.4.7	Enter New Unit ID . . . . .	26
3.4.8	Wired, Wi-Fi and Bluetooth® MAC IDs . . . . .	27
3.4.9	Reset Configuration . . . . .	27
<b>4.0</b>	<b>Configuration . . . . .</b>	<b>28</b>
4.1	Setup Switch . . . . .	28
4.2	Main Menu . . . . .	28
4.3	Audit Menu . . . . .	29
4.4	Setup Menu . . . . .	29
4.4.1	Setup – Configuration Menu . . . . .	30
4.4.2	Setup – Format Menu . . . . .	31
4.4.3	Setup – Calibration Menu . . . . .	32
4.4.4	Setup – Communication Menu . . . . .	33
4.4.5	Setup – Stream Format Menu . . . . .	36
4.4.6	Setup – Print Format Menu . . . . .	36
4.4.7	Setup – Program Menu . . . . .	37
4.4.8	Setup – Digital I/O Menu . . . . .	39
4.5	MAC ID Menu . . . . .	39
<b>5.0</b>	<b>Calibration . . . . .</b>	<b>40</b>
5.1	Keypad Calibrations . . . . .	40
5.1.1	Span Calibration . . . . .	40
5.1.2	Linear Calibration . . . . .	41
5.2	Alternative Zero Calibrations . . . . .	41
5.2.1	Last Zero . . . . .	41
5.2.2	Temporary Zero . . . . .	41
5.2.3	Rezero . . . . .	41
5.3	EDP Command Calibration . . . . .	42
<b>6.0</b>	<b>Wi-Fi Configuration . . . . .</b>	<b>43</b>
6.1	Wi-Fi Setup . . . . .	43
6.2	Server Configuration . . . . .	46
6.3	Client Configuration . . . . .	47
6.4	Timeout Configuration . . . . .	49
6.5	Wireless Module Wi-Fi Specifications . . . . .	50
<b>7.0</b>	<b>Bluetooth® Configuration . . . . .</b>	<b>51</b>
7.1	Bluetooth® Setup . . . . .	51
7.2	Wireless Module Bluetooth® Specifications . . . . .	53
<b>8.0</b>	<b>Revolution . . . . .</b>	<b>54</b>
8.1	Connecting to the Indicator . . . . .	54
8.2	Saving and Transferring Data . . . . .	54
8.2.1	Saving Indicator Data to a PC . . . . .	54
8.2.2	Downloading Configuration Data from PC to Indicator . . . . .	54
8.3	Updating Firmware . . . . .	54
<b>9.0</b>	<b>EDP Commands . . . . .</b>	<b>55</b>
9.1	Key Press Commands . . . . .	55
9.2	Reporting Commands . . . . .	56
9.3	Reset Configuration Command . . . . .	56



Technical training seminars are available through Rice Lake Weighing Systems. Course descriptions and dates can be viewed at [www.ricelake.com/training](http://www.ricelake.com/training) or obtained by calling 715-234-9171 and asking for the training department.

9.4	Parameter Setting Commands	57
9.5	Serial Port Commands	58
9.6	USB Commands	58
9.7	TCP Server and Client Commands	59
9.8	Wi-Fi and Bluetooth® Commands	59
9.9	Wired Ethernet Commands	59
9.10	Stream Setting Commands	60
9.11	Feature Commands	60
9.12	Print Format Commands	60
9.13	Regulatory Commands	61
9.14	Digital I/O Commands	61
9.15	Weigh Mode Commands	61
<b>10.0</b>	<b>Maintenance</b>	<b>62</b>
10.1	Maintenance Checkpoints	62
10.2	Field Wiring	62
10.3	Troubleshooting Tips	62
<b>11.0</b>	<b>Appendix</b>	<b>63</b>
11.1	Error Messages	63
11.1.1	Displayed Error Messages	63
11.2	ZZ EDP Command	63
11.3	Audit Trail Support	63
11.4	Conversion Factors for Secondary Units	64
11.5	Continuous Data (Stream) Output Formats	64
11.5.1	Rice Lake Weighing Systems Stream Format (RLWS)	64
11.5.2	Cardinal Stream Format (cardnal)	65
11.5.3	Avery Weigh-Tronix Stream Format (wtronix)	65
11.5.4	Mettler Toledo Stream Format (toledo)	66
11.6	Digital Filtering	66
11.6.1	Digital Rolling Average Filter (AVGONLY)	66
11.6.2	Adaptive Filter (ADPONLY)	67
11.6.3	Damping Filter (DMPONLY)	68
11.7	ASCII Character Chart	69
11.8	Front Panel Display Characters	70
<b>12.0</b>	<b>Specifications</b>	<b>71</b>



Rice Lake continually offers web-based video training on a growing selection of product-related topics at no cost. Visit [www.ricelake.com/webinars](http://www.ricelake.com/webinars)

# 1.0 Introduction

This manual is intended for use by service technicians responsible for installing and servicing Tracer AV2 instrumentation. Configuration and calibration of the Tracer AV2 can be accomplished using the 5-button keypad or the EDP command set. See [Section 4.0 on page 28](#) and [Section 5.0 on page 40](#) for information about configuration and calibration.



Manuals are available from Rice Lake Weighing Systems at [www.ricelake.com/manuals](http://www.ricelake.com/manuals)

Warranty information is available at [www.ricelake.com/warranties](http://www.ricelake.com/warranties)

## 1.1 Safety

### Safety Definitions:



**DANGER:** Indicates an imminently hazardous situation that, if not avoided, will result in death or serious injury. Includes hazards that are exposed when guards are removed.



**WARNING:** Indicates a potentially hazardous situation that, if not avoided, could result in serious injury or death. Includes hazards that are exposed when guards are removed.



**CAUTION:** Indicates a potentially hazardous situation that, if not avoided, could result in minor or moderate injury.



**IMPORTANT:** Indicates information about procedures that, if not observed, could result in damage to equipment or corruption to and loss of data.

### General Safety



**Do not operate or work on this equipment unless this manual has been read and all instructions are understood. Failure to follow the instructions or heed the warnings could result in injury or death. Contact any Rice Lake Weighing Systems dealer for replacement manuals.**



#### WARNING

**Failure to heed could result in serious injury or death.**

**Some procedures described in this manual require work inside the enclosure. These procedures are to be performed by qualified service personnel only.**

**Ensure the power cord is disconnected from the outlet before opening the unit.**

**Do not allow minors (children) or inexperienced persons to operate this unit.**

**Do not operate without the enclosure completely assembled.**

**Do not use for purposes other than weight taking.**

**Do not place fingers into slots or possible pinch points.**

**Do not use this product if any of the components are cracked.**

**Do not exceed the rated specifications of the unit.**

**Do not make alterations or modifications to the unit.**

**Do not remove or obscure warning labels.**

**Do not use solvents or aggressive substances to clean the unit.**

**Do not submerge.**

## 1.2 FCC Compliance

### United States

This equipment has been tested and found to comply with the limits for a Class A digital device, pursuant to Part 15 of the FCC Rules. These limits are designed to provide reasonable protection against harmful interference when the equipment is operated in a commercial environment. This equipment generates, uses and can radiate radio frequency energy and, if not installed and used in accordance with the instruction manual, may cause harmful interference to radio communications. Operation of this equipment in a residential area is likely to cause harmful interference in which case the user will be required to correct the interference at his own expense.

### Canada

This digital apparatus does not exceed the Class A limits for radio noise emissions from digital apparatus set out in the Radio Interference Regulations of the Canadian Department of Communications.

Le présent appareil numérique n'émet pas de bruits radioélectriques dépassant les limites applicables aux appareils numériques de la Class A prescrites dans le Règlement sur le brouillage radioélectrique édicté par le ministère des Communications du Canada.

## 1.3 Disposal



### Product Disposal

The product must be brought to appropriate separate waste collection centers at the end of its life cycle.

Proper separate collection to recycle the product helps prevent possible negative effects on the environment and to health, and promotes the recycling of the materials. Users who dispose of the product illegally shall face administrative sanctions as provided by law.

## 1.4 Overview

The Tracer AV2 is a single-channel digital weight indicator comprised of three components:

- Tracer AV2 CPU Enclosure – houses the CPU board; there are five external DB-9 connectors for two remote displays, a remote keypad, a load cell and a serial communications connection; there is an external Micro USB port and Ethernet port for additional communications options
- RD-2A Remote Display – 0.8 in (20 mm), seven-digit, seven-segment LCD display
- Remote Keypad – five keys with different functions depending on the operating mode

## 1.5 Operating Modes

The Tracer AV2 has three modes of operation:

### Weigh Mode

Weigh mode is the default mode. The Tracer AV2 displays gross weights, using the annunciators to indicate scale status and the unit type of the displayed weight value. Once configuration is complete and a legal seal is affixed, this is the primary mode in which the Tracer AV2 can operate.

### Setup Mode

Most of the procedures described in this manual, including configuration and calibration, require the Tracer AV2 to be in setup mode. See [Section 4.0 on page 28](#) for the procedure to enter setup mode and all the parameters available.

### User Mode

User mode is accessible by pressing and holding the **ENTER** key on the remote keypad for 15 seconds. The indicator displays the Audit, MAC ID and Version menus when in user mode.



## 2.0 Installation

This section describes installation procedures for the Tracer AV2 components. Instructions and figures are provided on how to connect the load cell/scale, remote display(s), remote keypad(s) and communication cables to the Tracer AV2 CPU enclosure. Dimension drawings as well as instructions for mounting and sealing are also included. Lastly, this section includes an assembly drawing and parts list for the service technician.



**Risk of electrical shock.**  
**Risque de choc.**

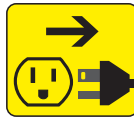

**Disconnect power before servicing.**  
**Débranchez l'alimentation avant l'entretien.**



**CAUTION: Risk of explosion if battery is replaced by an incorrect type. Dispose of used batteries according to state and local regulations.**



**AVERTISSEMENT: Risque d'explosion si la batterie est remplacée par un type incorrect. Mettre au rebut les batteries usagées selon les règlements d'état et locaux.**

Use anti-static protection for grounding and to protect components from electrostatic discharge (ESD) when working inside the Tracer AV2 components.

Procedures requiring work inside the Tracer AV2 components must be performed by qualified service personnel only.

The electric receptacle to the Tracer AV2 must be easily accessible.



**IMPORTANT: Only connect Ethernet and USB ports to equipment that has been certified to IEC 62368-1 or IEC 60950-1.**

**Only use the Rice Lake Weighing Systems 7.5 VDC 30 W power supply (PN 203937). Any replacement of the power supply and/or the detachable power cord must be a UL approved power supply and/or cord of the same rating or greater.**

### 2.1 Unpacking

Immediately after unpacking, visually inspect all components of the Tracer AV2 to ensure everything is included and undamaged. If any parts were damaged in shipment, notify Rice Lake Weighing Systems and the shipper immediately.

### 2.2 Component Dimensions

#### 2.2.1 CPU Enclosure Assembly

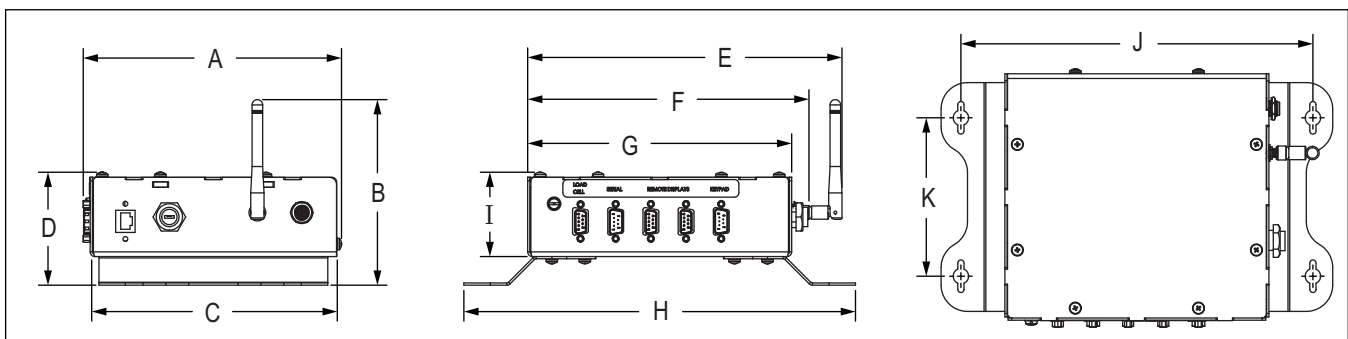

Figure 2-1. CPU Enclosure Assembly Diagram

A	B	C	D	E	F
7.3 in (18.55 cm)	5.3 in (13.47 cm)	7.0 in (17.78 cm)	3.2 in (8.13 cm)	8.9 in (22.61 cm)	8.0 in (20.32 cm)
G	H	I	J	K	
7.5 in (19.05 cm)	11.1 in (28.20 cm)	2.4 in (6.10 cm)	10.0 in (25.40 cm)	4.5 in (11.43 cm)	

Table 2-1. CPU Enclosure Assembly Dimensions

### 2.2.2 Remote Keypad (Panel Mount)

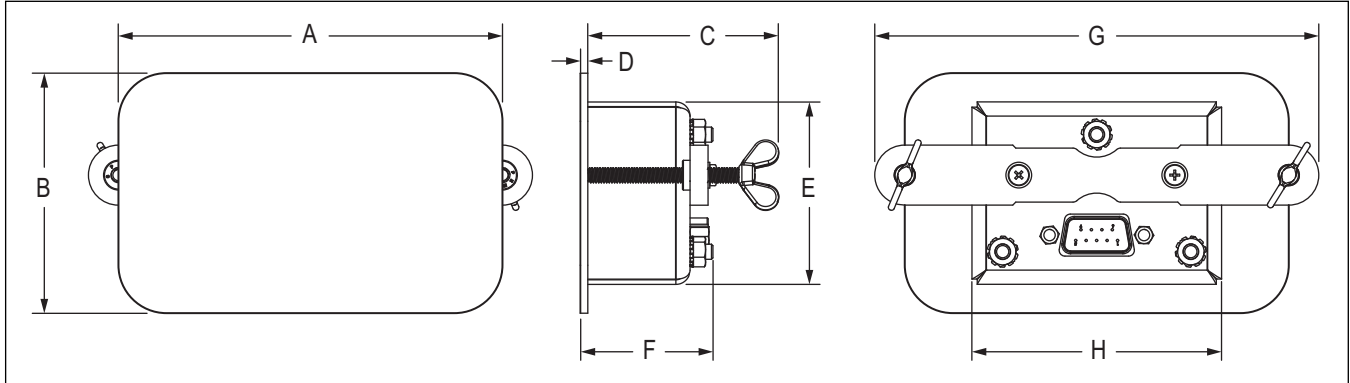

Figure 2-2. Keypad Panel Mount Diagram

A	B	C	D	E	F	G	H
4.00 in (10.16 cm)	2.50 in (6.35 cm)	1.98 in (5.03 cm)	0.063 in (0.16 cm)	1.90 in (4.83 cm)	1.38 in (3.51 cm)	4.63 in (11.76 cm)	2.60 in (6.61 cm)

Table 2-2. Keypad Panel Mount Dimensions

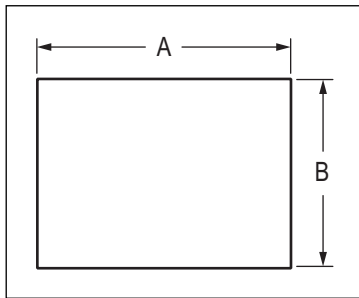

Figure 2-3. Keypad Panel Mount Cutout Diagram

A	B
2.70 in (6.86 cm)	2.00 in (5.08 cm)

Table 2-3. Keypad Panel Mount Cutout Dimensions

### 2.2.3 Remote Display (Panel Mount)

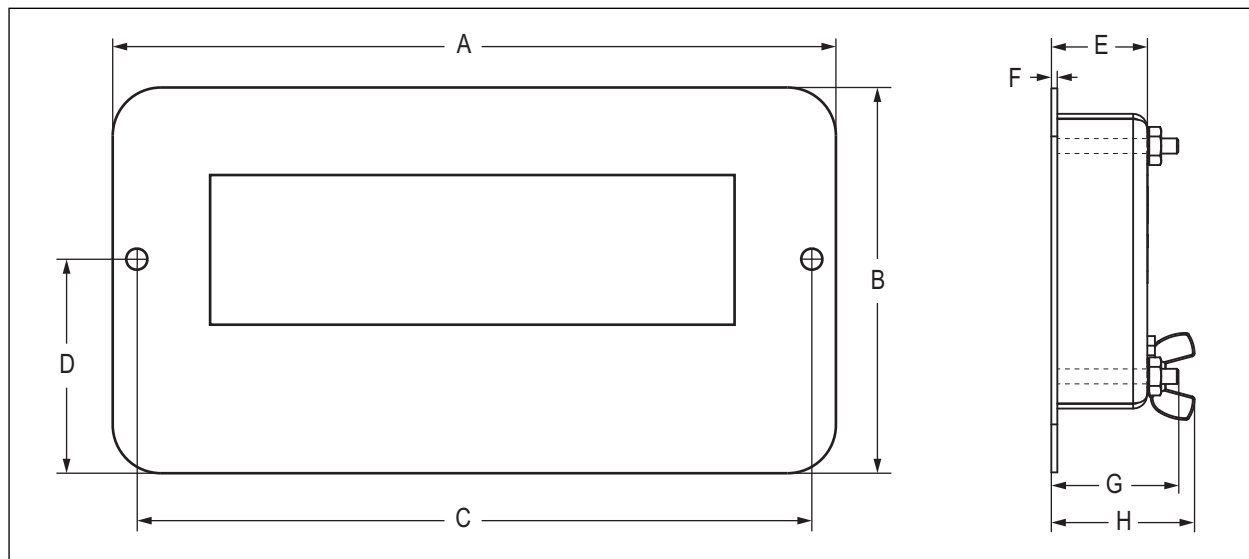

Figure 2-4. Remote Display Panel Mount Diagram

A	B	C	D	E	F	G	H
7.50 in (19.05 cm)	4.00 in (10.16 cm)	7.00 in (17.78 cm)	2.22 in (8 cm)	1.00 in (2.54 cm)	0.063 in (0.16 cm)	1.33 in (3.38 cm)	1.49 in (3.79 cm)

Table 2-4. Remote Display Panel Mount Dimensions

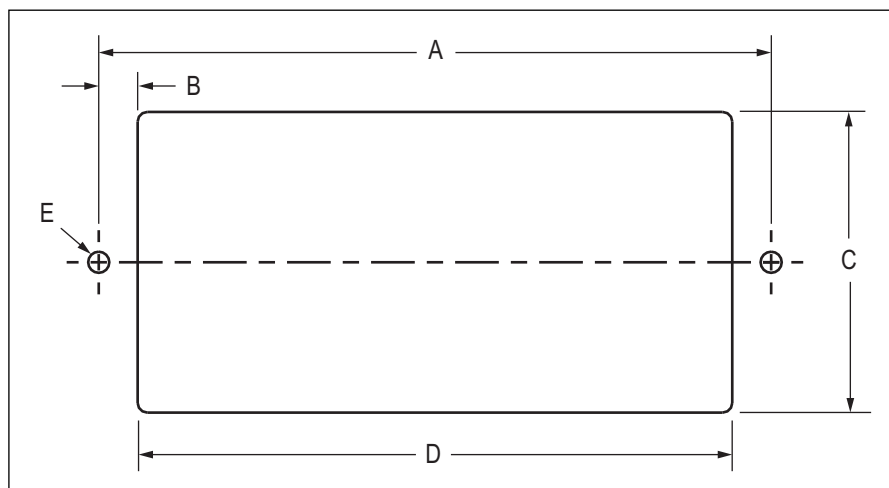

Figure 2-5. Remote Display Panel Mount Cutout Diagram

A	B	C	D	E
7.00 in (17.78 cm)	0.41 in (1.05 cm)	3.13 in (7.95 cm)	6.20 in (15.75 cm)	2X Ø 0.22 in (0.56 cm)

Table 2-5. Remote Display Panel Mount Cutout Dimensions

### 2.2.4 Remote Display (External Mount)

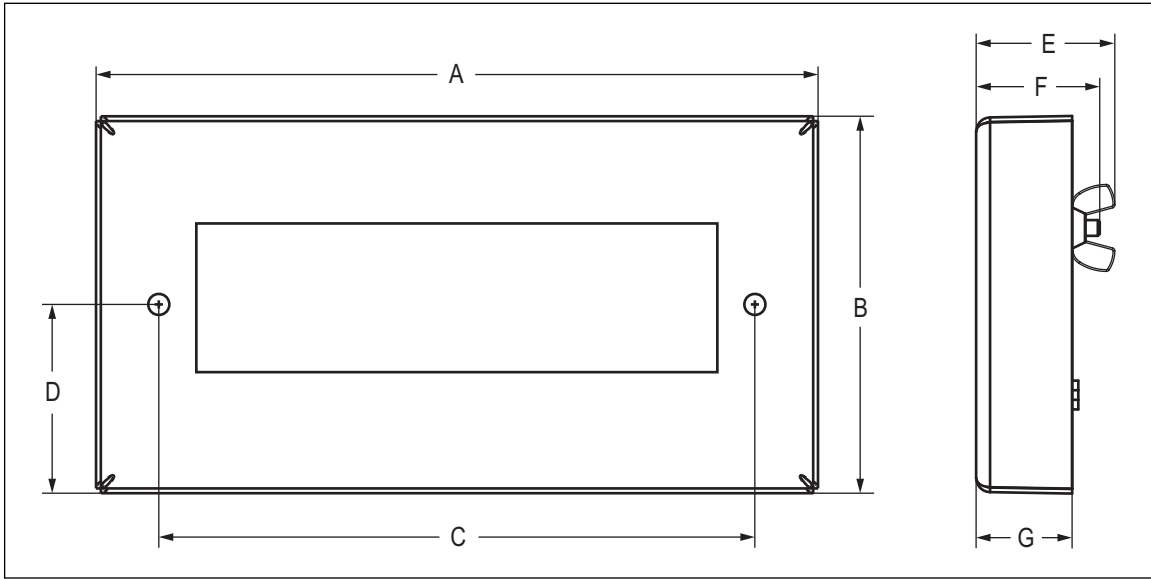

Figure 2-6. Remote Display External Mount Diagram

A	B	C	D	E	F	G
7.50 in (19.05 cm)	3.90 in (9.91 cm)	6.22 in (15.80 cm)	1.95 in (4.96 cm)	1.44 in (3.66 cm)	1.29 in (3.28 cm)	1.00 in (2.54 cm)

Table 2-6. Remote Display External Mount Dimensions

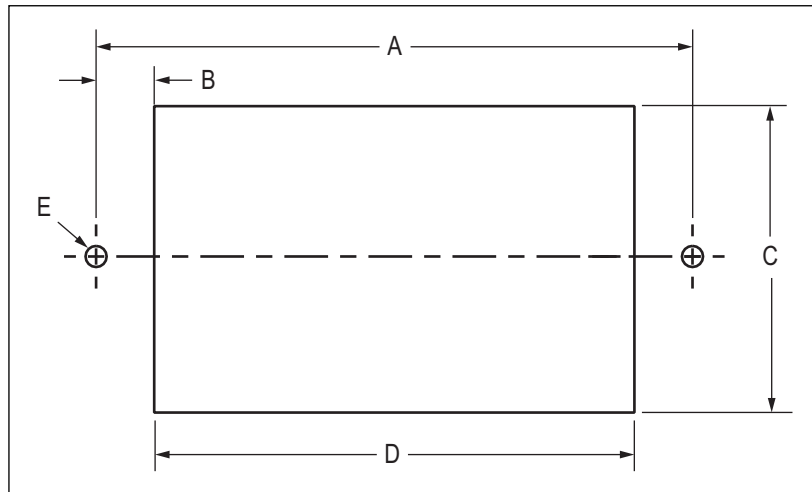

Figure 2-7. Remote Display External Mount Cutout Diagram

A	B	C	D	E
6.22 in (15.80 cm)	0.61 in (1.55 cm)	3.15 in (8.00 cm)	5.00 in (12.70 cm)	2X Ø 0.22 in (0.56 cm)

Table 2-7. Remote Display External Mount Cutout Dimensions

## 2.3 Mounting Brackets

The Tracer AV2 CPU enclosure can be mounted on a flat surface using the included mounting brackets.

### 2.3.1 Bracket Assembly

The mounting brackets come attached to the CPU enclosure, but can be removed and reassembled if needed.

1. Align the mounting brackets with the necessary holes on the underside of the CPU enclosure (Figure 2-8).
2. Secure the mounting brackets to the CPU enclosure with the six included screws. Torque screws to 10 in-lb (1.13 N-m).

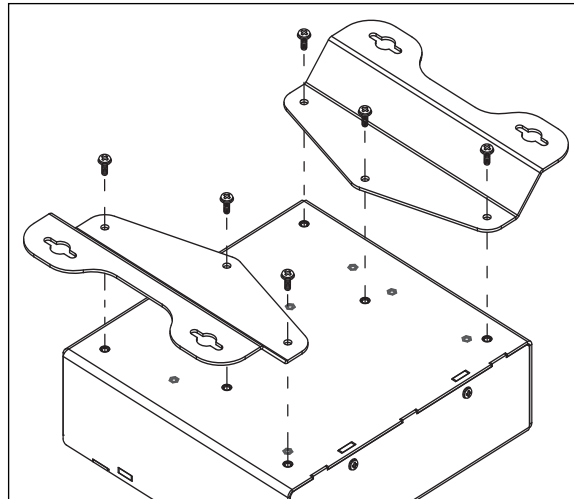

Figure 2-8. Secure Mounting Brackets

### 2.3.2 Mounting Instructions

Mounting fasteners are not included. Make sure to select appropriate fasteners based on the width and material of the flat mounting surface.

1. Using the mount as a template, mark the fastener locations on the mounting surface.



**NOTE:** See [Section 2.2.1 on page 9](#) for mounting hole dimensions.

2. Drill appropriately sized holes for the fasteners at the marked locations.
3. Secure the CPU enclosure assembly to the mounting surface with fasteners.

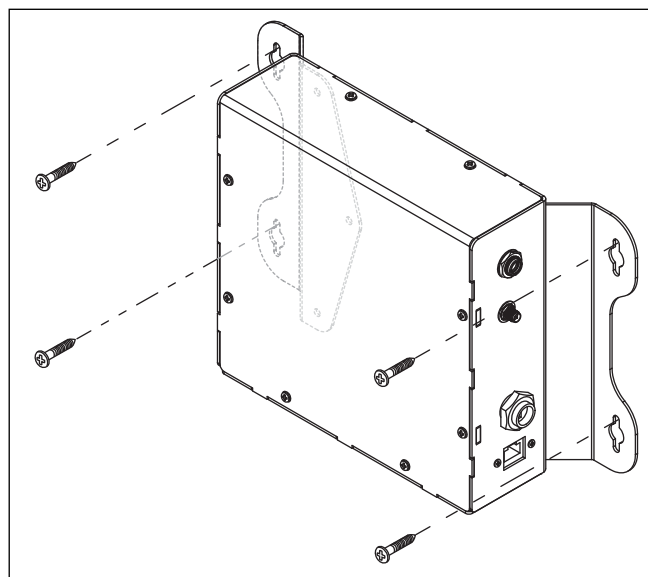

Figure 2-9. Secure CPU Enclosure Assembly to Mounting Surface

## 2.4 External Cable Connections

The Tracer AV2 CPU enclosure provides external connectors for all necessary cable connections. See the following sections to connect cables as required for the application. See [Figure 2-10](#) and [Table 2-8](#) for the cable connection locations and uses.

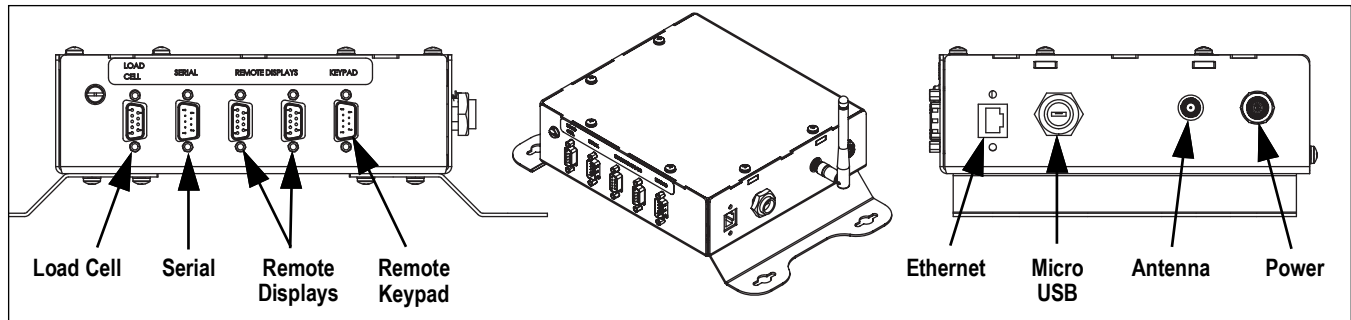

Figure 2-10. Cable Connection Locations

Use	Connector	Qty	Use	Connector	Qty
Load Cell	Female DB-9	1	Ethernet Comm	RJ45	1
Serial	Male DB-9	1	USB Comm	Micro USB	1
Remote Display	Female DB-9	2	Antenna	RSMA	1
Keypad	Male DB-9	1	Power	Barrel Jack	1

Table 2-8. Cable Connection Uses



**NOTE:** The antenna hole is keyed. Ensure the notches of the hole and the antenna are aligned for proper installation.

### 2.4.1 Load Cell Connector

A female DB-9 connector for the load cell cable connection is located on the exterior of the CPU enclosure. See [Figure 2-11](#) and [Table 2-9](#) for the connector pin assignments.

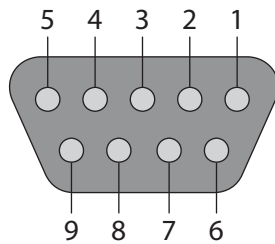

Figure 2-11. Load Cell Connector

Pin	Wire Color	Function
3	White	SIG-
4	Red	EXC+
6	Black	EXC-
7	Green	SIG+
1, 2, 5, 8, 9	-	-

Table 2-9. Load Cell Connector Pin Assignments

### 2.4.2 Serial Connector

A male DB-9 connector for the serial cable connection is located on the exterior of the CPU enclosure. See [Figure 2-12](#) and [Table 2-10](#) for the connector pin assignments.

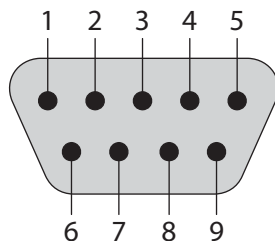

Figure 2-12. Serial Connector

Pin	Wire Color	Function
2	Red	TX1
3	Green	RX1
5	Black	GND
1, 4, 6, 7, 8, 9	-	-

Table 2-10. Serial Connector Pin Assignments

### 2.4.3 Remote Display Connectors

Two female DB-9 connectors for the remote display cable connections are located on the exterior of the CPU enclosure. See [Figure 2-13](#) and [Table 2-11](#) for the pin assignments for both connectors.

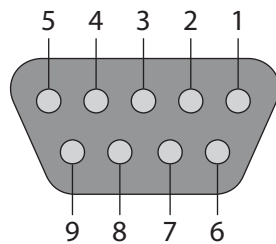

Figure 2-13. Display Connector

Pin	Wire Color	Function
1	Red	6V-10V
2	Black	GND
9	Blue	TX (RS-232)
3, 4, 5, 6, 7, 8	–	–

Table 2-11. Display Connector Pin Assignments

### 2.4.4 Remote Keypad Connector

A male DB-9 connector for the remote keypad cable connection is located on the exterior of the CPU enclosure. When a key is pressed, it shorts two pins as shown in [Table 2-12](#) with the X's. For example, by pressing the ENTER key, pin 6 is shorted to pin 8. See [Figure 2-14](#) and [Table 2-12](#) for the connector pin assignments.

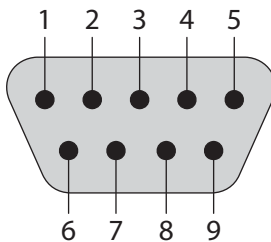

Figure 2-14. Keypad Connector

Pin	ENTER	PRINT	ZERO	UNITS	ACCUM
1		X			
6	X				X
7			X	X	
8	X	X		X	
9			X		X
2, 3, 4, 5	–	–	–	–	–

Table 2-12. Keypad Connector Pin Assignments Matrix

## 2.5 System Illustrations

### 2.5.1 System Configuration 1

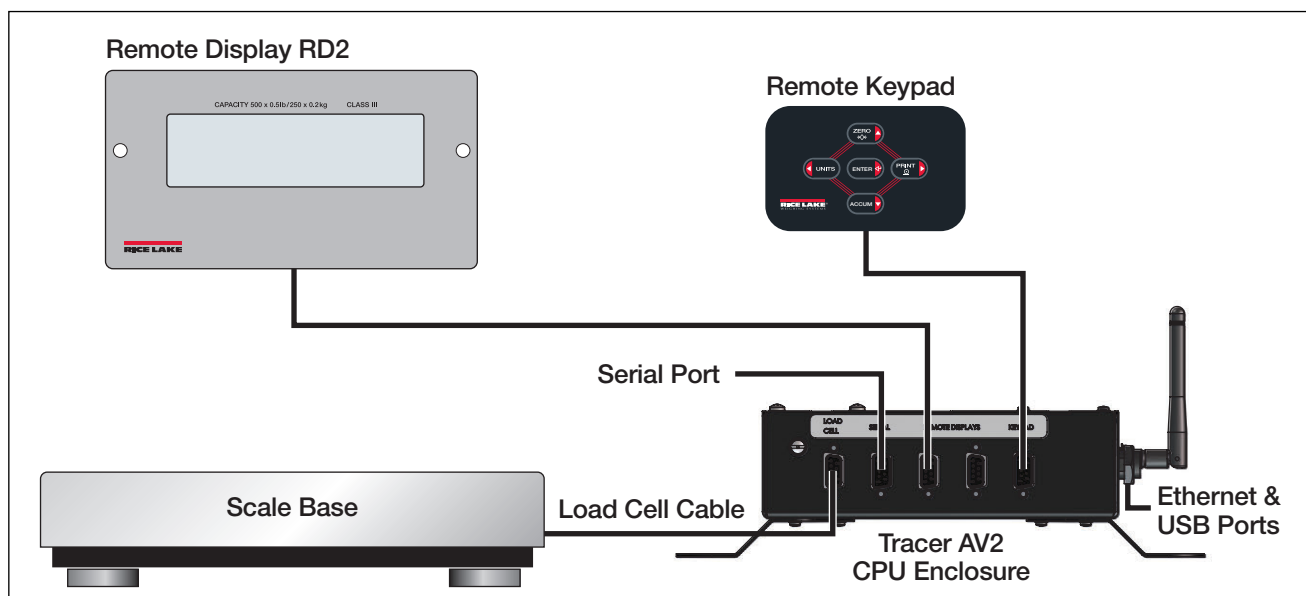

Figure 2-15. System Configuration 1 – Single Display with Single Keypad

### 2.5.2 System Configuration 2

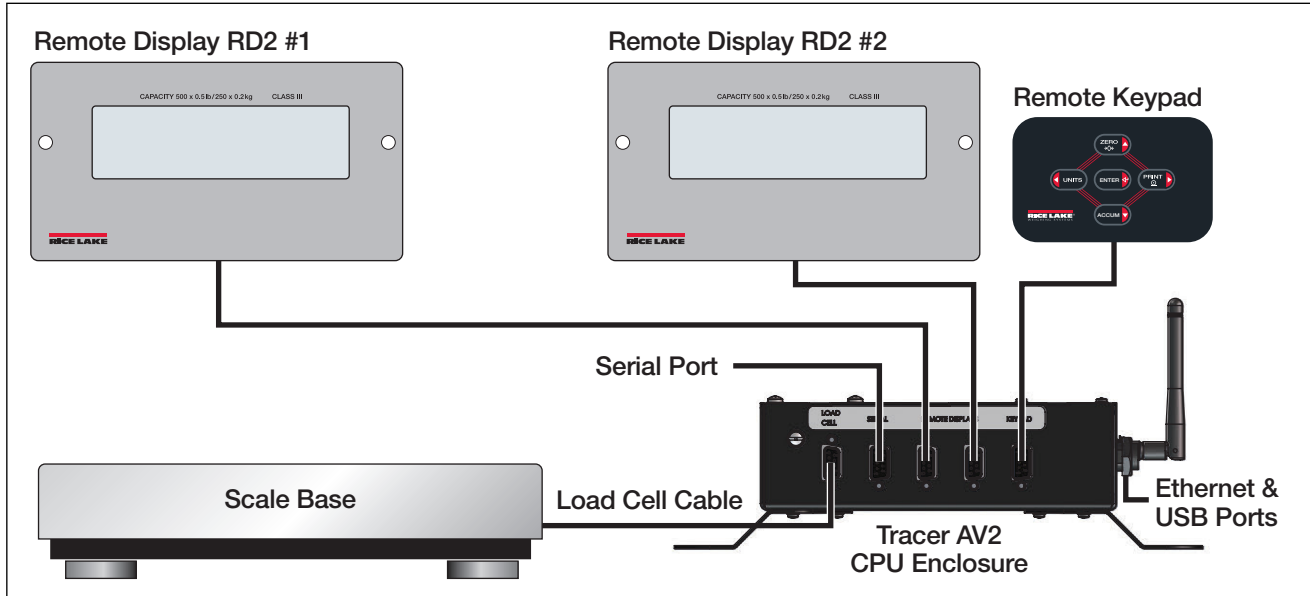

Figure 2-16. System Configuration 2 – Dual Displays with Single Keypad

### 2.5.3 System Configuration 3

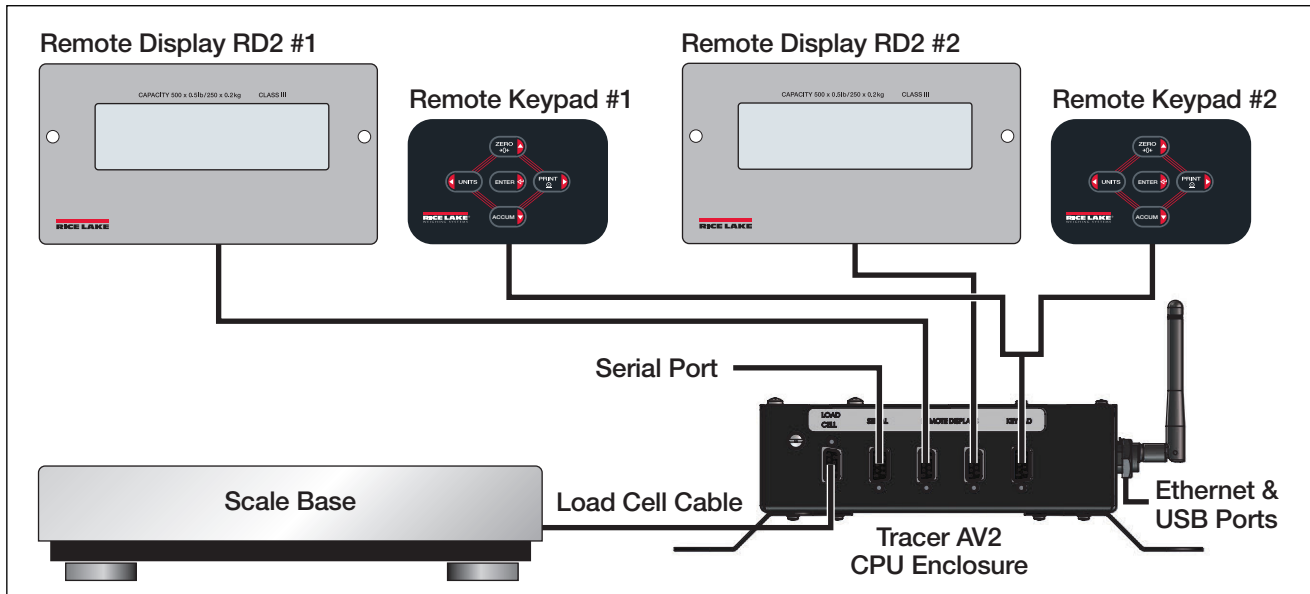

Figure 2-17. System Configuration 3 – Dual Displays with Dual Keypads



**NOTE:** The Tracer AV2 PN 207287 includes a DB-9 splitter (PN 207302) and two DB-9 cables (PN 50749) for dual keypad use. The DB-9 splitter connects to the keypad connector and DB-9 cables used to connect DB-9 splitter to keypads.



## 2.6 Interior Access

Open the Tracer AV2 CPU enclosure by removing the eight screws that secure the cover plate. The removal of a wire seal voids any Legal for Trade certification.

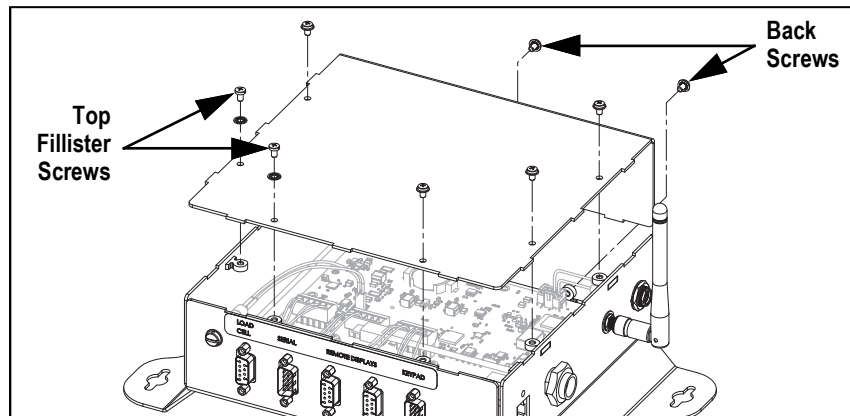

Figure 2-18. Cover Plate Screw Locations

Once work inside of the CPU enclosure is complete, reattach the cover plate to the enclosure assembly. Align the cover plate and install the six top screws and two back screws. Torque screws to 10 in-lb (1.13 N-m).

## 2.7 CPU Board

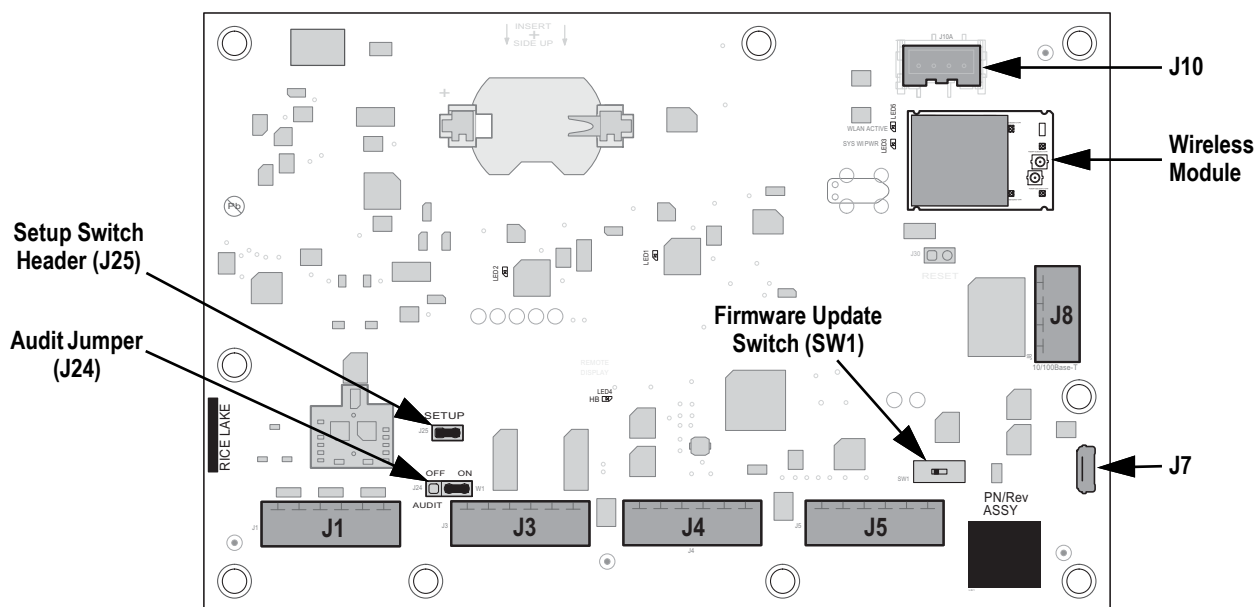

Figure 2-19. Tracer AV2 CPU Board

### Connectors

- Load Cell (J1)
- Display 1-2 (J4)
- Micro USB (J7)
- Power (J10)
- RS-232 1-2 (J3)
- Digital I/O (J5)
- Ethernet (J8)
- Wireless Module



**NOTE:**  $\mu$ .FL end of the antenna cable is connected to the wireless module.

RJ45 port cable assembly is connected to J8 Ethernet connector.

Micro USB service port cable is connected to J7 Micro USB connector.

Keypad ribbon cable is connected to J26 overlay/HMI connector on the backside of the CPU board.

The Tracer AV2 does not support real-time clock (RTC) and therefore doesn't need or include a battery.

### 2.7.1 Load Cell

The J1 connector on the CPU board ([Section 2.7 on page 17](#)) is factory wired to the exterior DB-9 load cell connector. See [Table 2-13](#) for the pin assignments for the J1 connector.

J1 Pin	Load Cell Function	Wire Color	DB-9 Pin
1	+SIG	Green	7
2	-SIG	White	3
3	+SENSE	-	-
4	-SENSE	-	-
5	+EXC	Red	4
6	-EXC	Black	6

Table 2-13. J1 Pin Assignments (Load Cell)



**NOTE:** For a 4-wire installation leave pins 3 and 4 empty on the connector. 4-wire is the default load cell wiring. For a 6-wire installation set the SENSE parameter to 6-WIRE in the CONFIG menu ([Section 4.4.1 on page 30](#)).

### 2.7.2 RS-232 Serial Communication

The J3 connector on the CPU board ([Section 2.7 on page 17](#)) is factory wired to the exterior DB-9 serial connector. Only RS-232 port 1 is available through the DB-9 connector. See [Table 2-14](#) for the pin assignments for the J3 connector.

J3 Pin	RS-232 Function	Wire Color	DB-9 Pin
1	GND	Black	5
2	RX1	Green	3
3	TX1	Red	2
4, 5, 6	-	-	-

Table 2-14. J3 Pin Assignments (Serial Communication)

### 2.7.3 Remote Displays

The J4 connector on the CPU board ([Section 2.7 on page 17](#)) is factory wired to two exterior DB-9 connectors for dual remote displays. See [Table 2-15](#) for the pin assignments for the J4 connector.

J4 Pin	Display #1 Function	Wire Color	DB-9 #1 Pin	J4 Pin	Display #2 Function	Wire Color	DB-9 #2 Pin
1	GND	Black	2	4	GND	Black	2
2	6V-10V	Red	1	5	6V-10V	Red	1
3	TX (RS-232)	Blue	9	6	TX (RS-232)	Blue	9

Table 2-15. J4 Pin Assignments (Remote Displays)

## 2.8 Sealing the Indicator (Optional)

Use a lead wire seal through three fillister screws. This restricts access of the setup switch, electronics, electrical contacts and Legal for Trade configuration parameters. This wire prevents the Tracer AV2 from being tampered with by an unauthorized individual. If the wire seal is removed, NTEP certification will become void.

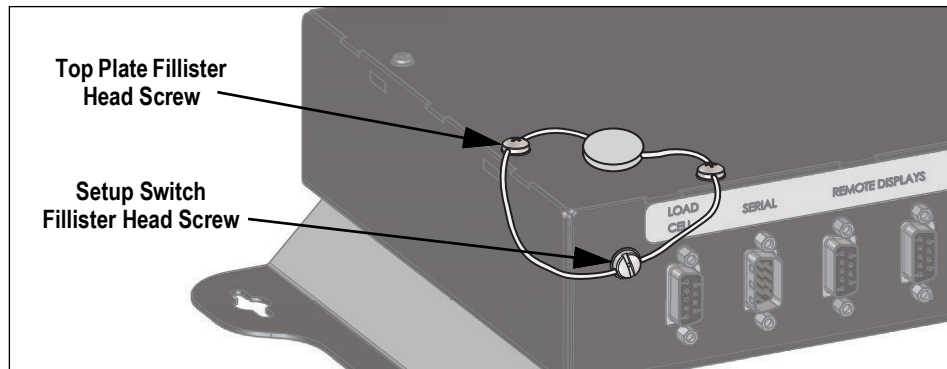

Figure 2-20. Sealing the Indicator – No Access

1. Navigate the sealing wire through the fillister head screws on the top plate and the fillister head screw on the side next to the DB-9 connectors (setup switch screw), as shown in [Figure 2-20](#).
2. Seal the wire to secure.

## 2.9 Replacement Parts

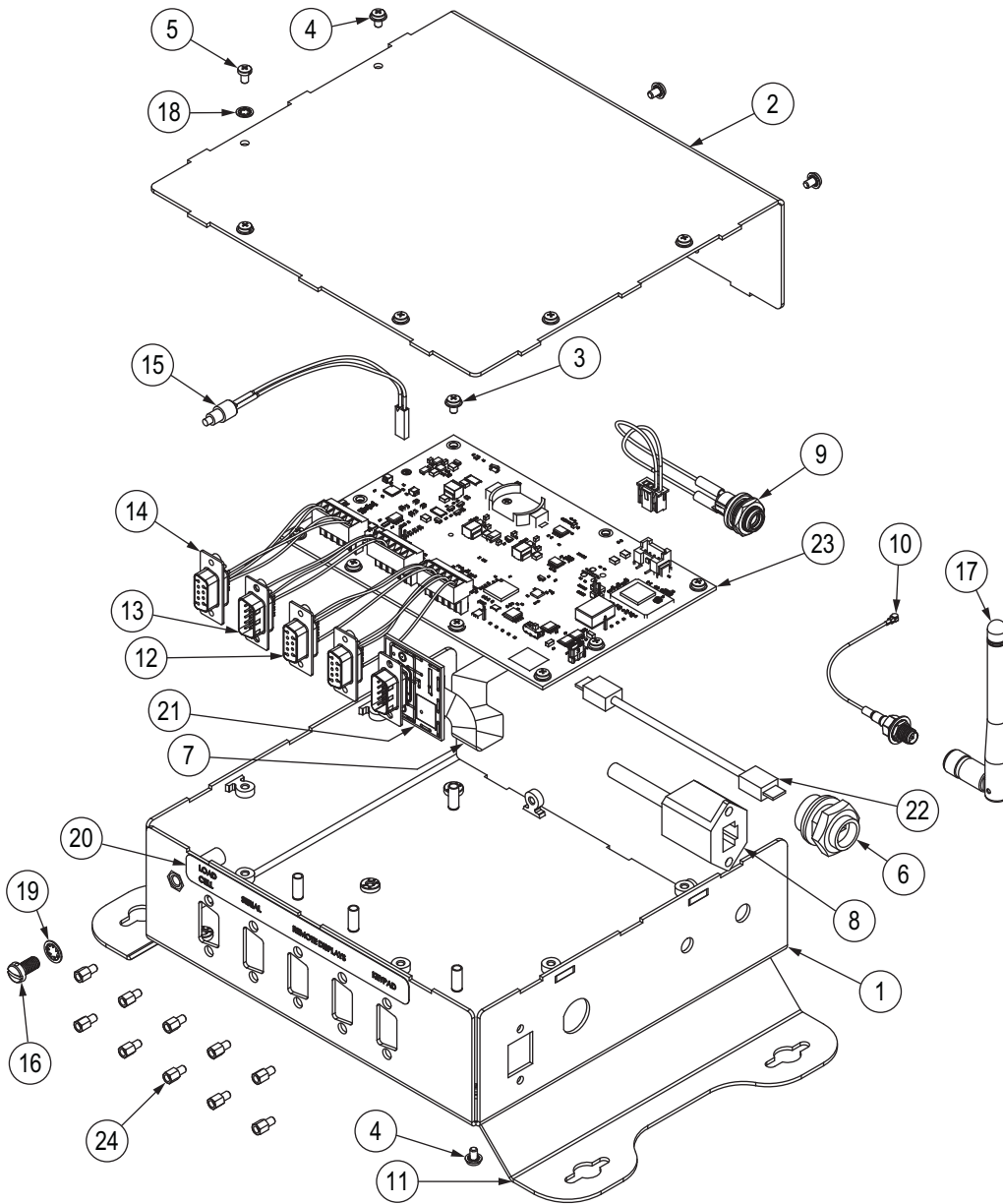

Figure 2-21. Replacement Parts Diagram



**NOTE:** All hardware should be torqued to 10 in-lb (1.13 N-m).

## 2.9.1 Replacement Parts List

Item No.	Part No.	Description	Qty
1	202088	Enclosure, Tracer AV2 CPU Box	1
2	202089	Cover, Tracer AV2 CPU Box	1
3	206442	Screw, M3-0.5x10 Phillips Pan Head Zinc Finish Steel External Tooth Washer SEMS	7
4	202140	Screw, M4-0.7x10 Phillips Pan Head Zinc Finish Steel External Tooth Washer SEMS	12
5	194219	Screw, M4x0.7 X 10 Phillips Drilled Cheese Head SST	2
6	203731	Connector, USB A to B Micro Panel	1
7	207172	Ribbon Cable, 14 Position 1.0 mm Pitch, 5.98 Inch Fpc	1
8	208686	Cable Assembly, RJ45 Jack to 4 Position Connector	
9	203773	Cable Assembly, Power Harness, 2 Position, 2.5 mm Barrel Jack	1
10	112228	Cable, RF UFL to RSMA, 6 Inch Length	1
11	203827	Bracket, Tracer AV2 Wall Mount	2
12	204340	Cable Assembly, Dual Remote Displays, Dual Female DB-9 Connectors	1
13	204341	Cable Assembly, Serial, Male DB-9 Connector	1
14	204342	Cable Assembly, Load Cell, Female DB-9 Connector	1
15	193108	Setup Switch Assembly, Remote	1
16	180861	Screw, M5x0.8x10 mm Slotted Drilled Cheese Head SST	1
17	98357	Antenna, 2.4 GHz 802.11b/g	1
18	15134	Washer, Lock No 8 Type A Internal Tooth Steel Zinc Plated	2
19	15140	Washer, Lock No 10 Type A Internal Tooth	1
20	207163	Label, Tracer AV2 I/O	1
21	201805	Board Assembly, 5 Button Keypad Adapter Board, Male DB-9 Connector	1
22	203733	Cable, USB Micro-B Male to Micro-B Male, 8 Inch	1
23	209642	Board Assembly, CPU Tracer AV2 Indicator, ROHS	1
24	15704	Connector, Mounting Kit D-Sub Chassis Mounting Hardware	10
–	205206	Assembly, Tracer AV2 CPU Box Airline Kiosk	–
–	207288	Kit, RD-2A LCD Display Panel Mount	–
–	207289	Kit, RD-2A LCD Display External Mount	–
–	207290	Kit, Single 5 Button Keypad	–
–	207292	Kit, Dual 5 Button Keypad	–
–	207302	Cable, RS-232 Splitter, DB-9 Female to Two DB-9 Male Connectors	–
–	50749	Cable, DB-9 Female to DB-9 Female, Straight Through Wired	–

Table 2-16. Replacement Parts

## 2.9.2 Available Product Part Numbers

Item	Description	Panel Mount Display	External Mount Display	Keypad
202532	Tracer AV2, Single LCD Panel Mount Display, Single Keypad for Baggage Scale	1	–	1
202531	Tracer AV2, Dual LCD Panel Mount Display, Single Keypad for Baggage Scale	2	–	1
207287	Tracer AV2, Dual LCD Panel Mount Display, Dual Keypad for Baggage Scale	2	–	2
204452	Tracer AV2, Single LCD External Mount Display, Single Keypad for Baggage Scale	–	1	1
204451	Tracer AV2, Dual LCD External Mount Display, Single Keypad for Baggage Scale	–	2	1

Table 2-17. LED Annunciators



**NOTE:** The Tracer AV2 PN 207287 includes a DB-9 splitter (PN 207302) and two DB-9 cables (PN 50749) for dual keypad use. The DB-9 splitter connects to the keypad connector and DB-9 cables used to connect DB-9 splitter to keypads.

## 3.0 Operation

The front panel consists of a seven-segment display with seven 0.8 in (20 mm) tall digits. A negative number displays as six digits plus the negative symbol. There are five LCD annunciators for units and scale functions.

### 3.1 Display

Figure 3-1 shows the Tracer AV2 LCD display with annunciators showing.



Figure 3-1. Front Panel Display

#### 3.1.1 LCD Annunciators

The Tracer AV2 display uses a set of five LCD annunciators to provide additional information about the value being displayed.

Item	Description
<b>Gross</b>	Gross – Displays when weight is in Gross weight
→0←	Center of Zero – Indicates the current gross weight reading is within $\pm 0.25$ display divisions of the acquired zero, or is within the center of zero band; A display division is the resolution of the displayed weight value, or the smallest incremental increase or decrease which can be displayed or printed; This annunciator displays when scale is zeroed
▽ ▾	Standstill – Scale is at standstill or within the specified motion band; Some operations, including zero and print, can only be done when the standstill annunciator is shown
<b>lb</b>	Pound (lb) and Kilogram (kg) – Displays which unit of measure is being used; lb and kg annunciators indicate the units associated with the displayed value; The lb and kg annunciators function as primary and secondary unit annunciators
<b>kg</b>	

Table 3-1. LCD Annunciators

## 3.2 Remote Keypad

Figure 3-2 shows the Tracer AV2 remote keypad, which includes five tactile buttons on a flat membrane panel. In setup mode, the keys are used to navigate through menus, select digits within numeric values and increment/decrement values.

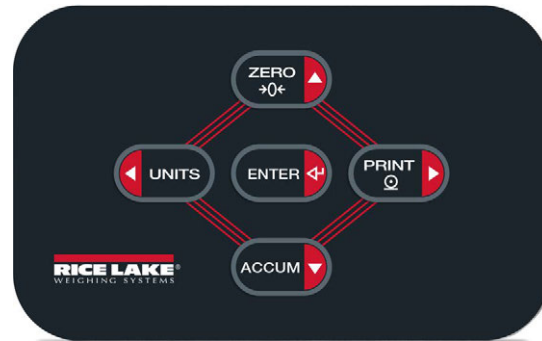

Figure 3-2. 5-Button Keypad

Key	Function
	Sets the current gross weight to zero, provided the amount of weight to be removed or added is within the specified zero range and the scale is not in motion; The zero band is defaulted to $\pm 1.9\%$ of full scale, but can be configured for up to 100% of full scale; Also used as the up key to navigate menus and to exit to weigh mode
	Switches the weight display to an alternate unit; The alternate unit is defined in the Configuration menu, and could be kg or lb; Also used as the left key to navigate menus or to toggle to another digit when editing a value
	Sends on-demand print format out the configured port, provided the conditions for standstill are met; RS-232 port 1 is the default print port; Also used as the right key to navigate menus or to toggle to another digit when editing a value
	Used to access user mode; Acts as an enter key for numeric or parameter entry; Key hold time to access user menu is configurable from 0 to 30 seconds in the key hold menu with the menudly parameter (defaulted to 10 seconds)
	Performs accumulator print function, when the print format MODE is set to MULTI (Section 4.4.6 on page 36); Also used as the down key to navigate menus

Table 3-2. Buttons and Descriptions

## 3.3 General Navigation

The remote keypad's function buttons are also used to navigate through the menu structure.

- Press and hold to access user menu









**NOTE:** Default enter key hold time to access user menu is 10 seconds. Time is configurable from 0 to 30 seconds in the `KEYHOLD` menu with the `MENUDLY` parameter (see Table 4-14 on page 37).





- and move left and right (horizontally) in a menu level
- and move up and down to different menu levels
- to exit menu and return to weigh mode
- selects parameter settings or values

### 3.3.1 Numeric Value Entry

Several parameters in the menu structure require the operator to enter a numeric value rather than make a selection. Follow this procedure to enter a numeric value:

1. Press  to enter into a parameter. The current parameter value displays with the first digit flashing.
2. Press  or  to move to the digit to be edited.
3. Press  or  to increase/decrease the value of the digit.
4. For integers, press  to save the value and the next parameter in the menu displays.

– OR –

For decimal numbers, press  to select the decimal point, causing it to blink. Press  or  to move the decimal point. Press  again to save the value and the next parameter in the menu displays.













### 3.3.2 Alphanumeric Entry

Several parameters in the menu structure require the operator to enter an alphanumeric value rather than make a selection.



**NOTE:** *The end of the alphanumeric character string is indicated by a space.*

Follow this procedure to enter an alphanumeric value:

1. Press  to enter into the parameter. The current parameter entry displays with the first digit flashing.
2. Press  or  to move to the digit to be edited.
3. Press  to enter into the character options for the digit location (includes space at the far right of the string).
4. Press  or  to scroll through available characters. Available characters are in order of their ASCII value. Refer to [Section 11.7 on page 69](#) for ASCII values of characters.
5. Press  to select the currently displayed character. The display returns to the current parameter entry with the next digit to the right flashing or with the space at the end of the entry as the next available digit location.
6. Press  to enter into the character options again for the next digit location.
7. Press  again to clear the current character.
8. Press  to insert a new “space” character to the left of the currently selected digit location and then press  to enter into the character options for the new “space” location.
9. Repeat the previous steps until alphanumeric entry is complete.
10. Press  to save the entry and the next parameter in the menu displays.





**NOTE:** *It is not possible to exit the value with an invalid entry. Double pressing  to delete digits is a good way to clear the entry to start over.*



## 3.4 General Operation

This section summarizes basic Tracer AV2 operations.



### 3.4.1 Zero Scale



1. In gross mode, remove all weight from the scale and wait for the  LED to light.
2. Press . The  LED lights to indicate the scale is zeroed.



**NOTE:** The scale must be stable and within the configured zero range for the scale to be zeroed.



### 3.4.2 Print Ticket



1. Place item to be weighed on the scale.
2. Wait for the  LED to be lit.
3. Press  to send data to the configured port(s).

If the  LED is not lit and  is pressed, the print action only occurs if the scale comes out of motion within three seconds. If the scale stays in motion for over three seconds, the  press is ignored.

### 3.4.3 Print Accumulator Ticket

The accumulator function in the Tracer AV2 is not a standard, NTEP accumulator. It is an alternate print format that can be activated by the **ACCUM** key, when the print format MODE is set to MULTI ([Section 4.4.6 on page 36](#)).







1. Place item to be weighed on the scale.
2. Wait for the  LED to be lit.
3. Press  to save the weight data of the item and begin a new transaction. The weight data of the item is sent to the configured port(s) along with the associated bag number.
4. Remove item and let the scale return to zero.
5. Repeat [Steps 1-4](#) for all items to be weighed.
6. Press  to send total (accumulated) weight data to the configured port(s) and close out the transaction.

If the  LED is not lit and  is pressed, the print accumulator action only occurs if the scale comes out of motion within three seconds. If the scale stays in motion for over three seconds, the  press is ignored.

### 3.4.4 Toggle Units









Press  to toggle between primary and secondary units. The current unit LCD annunciator displays.

### 3.4.5 View Legally Relevant Version

1. Press . **AUDIT** displays.
2. Press . **LRU** displays.
3. Press . The legally relevant version displays.
4. Press  or  to return the audit menu parameters.
5. Press  twice to return to weigh mode.









### 3.4.6 View Audit Trail Counters

The audit trail calibration and configuration counters can be viewed in user mode.

1. Press . **AUDIT** displays.
2. Press . **CRU** displays.
3. Press . **CRUBR** displays.
4. Press . The audit trail calibration counter displays.
5. Press . **CONF** displays.
6. Press . The audit trail configuration counter displays.
7. Press  or  to return the audit menu parameters.
8. Press  twice to return to weigh mode.













### 3.4.7 Enter New Unit ID

Entering a new Unit ID requires access to setup mode ([Section 4.1 on page 28](#)).

1. Press . **AUDIT** displays.
2. Press . **SETUP** displays.
3. Press . **CONF** displays.
4. Press  to scroll until **PRGRN** displays.
5. Press . **PRUPN** displays.
6. Press  to scroll until **UID** displays.
7. Press . The current unit ID value displays.
8. Edit the value using the alphanumeric entry procedure ([Section 3.3.2 on page 24](#)).
9. Press  when the value is correct.
10. Press  three times to return to weigh mode.











### 3.4.8 Wired, Wi-Fi and Bluetooth® MAC IDs

The Wired MAC ID (⎓, rEd), the Wi-Fi MAC ID (⎓, F,) and the Bluetooth® MAC ID (bEoOeH) can be viewed through the top-level menu (Section 4.5 on page 39).

1. Press , RUD, t displays.
2. Press  or  to scroll through the menu options until ⎓RĒ, d displays.
3. Press , ⎓, rEd displays.
4. Press , 88-88-88-88-88-88 displays. Press  to scroll through the entire MAC address.
5. Press , ⎓, F, displays.
6. Press , 88-88-88-88-88-88 displays. Press  to scroll through the entire MAC address.
7. Press , bEoOeH displays.
8. Press , 88-88-88-88-88-88 displays. Press  to scroll through the entire MAC address.
9. Press  three times to return to weigh mode.

### 3.4.9 Reset Configuration

Resetting the configuration requires access to setup mode (Section 4.1 on page 28).

1. Press , RUD, t displays.
2. Press , SEtUP displays.
3. Press , COnF, G displays.
4. Press , dFLtCFG displays.
5. Press , nO displays.
6. Press , YES displays.
7. Press  or  to reset the configuration setting. oH displays indicating process is complete.
8. Press  or , nO displays again.
9. Press  three times to return to weigh mode.

## 4.0 Configuration

There are two types of configuration parameters in the Tracer AV2, setup mode parameters (or Legal for Trade configuration) and user mode parameters (or non-legal configuration). Setup mode parameters are accessed by pressing the setup switch (Section 4.1). User mode parameters are accessed by pressing and holding the **ENTER** key and do not require pressing the setup switch.

The following sections provide graphic representations of the Tracer AV2 menu structures. Most menu diagrams are accompanied by a table which describes all parameters and parameter values associated with the menu. The factory default setting appears at the top of each column in bold type.

The Audit, MAC ID and Version menus do not require pressing the setup switch.

The Setup menu is accessed by pressing the setup switch (Section 4.1).



**NOTE:** All weight-related parameters must be configured prior to calibrating the unit.

### 4.1 Setup Switch

In order to configure the Tracer AV2, it must be placed in setup mode with the setup switch. The setup switch is accessed through a small hole on the side of the CPU enclosure. Remove the setup switch screw and insert a non-conductive tool into the access hole to press the setup switch.



**IMPORTANT:** Use caution when inserting the non-conductive tool into the enclosure. Insert the tool about 3/4 in (19 mm), until the switch is engaged. Do not use excessive force which could damage the switch.

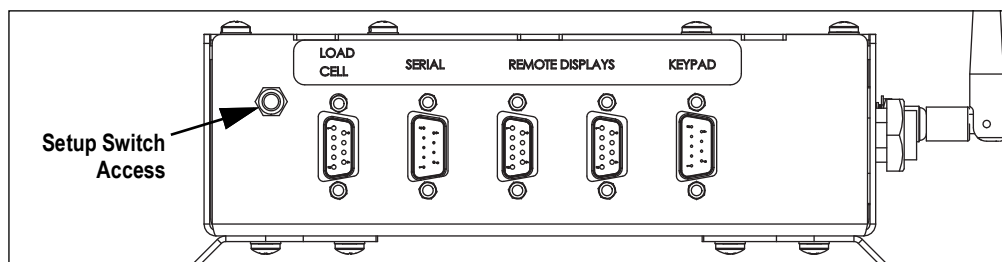

Figure 4-1. Setup Switch Access

When the Tracer AV2 is placed in setup mode, the setup menu is accessed and config displays. See Section 4.4 on page 29 for a detailed breakdown of this menu. Torque the setup switch screw to 10 in-lb (1.13 N-m) when reinserting.

### 4.2 Main Menu



Figure 4-2. Main Menu

Menu	Description
AUDIT	Audit – Displays the legally relevant firmware version and allows access to view/print audit trail information; See Section 4.3 on page 29
SETUP	Setup – Set configuration parameters for indicator (only accessible in setup mode); See Section 4.4 on page 29
MAC ID	MAC ID – Displays the wired Ethernet, Wi-Fi, and Bluetooth® MAC Addresses (read only); See Section 4.5 on page 39
VER5	Version – Displays the installed firmware version number

Table 4-1. Main Menu Descriptions

### 4.3 Audit Menu

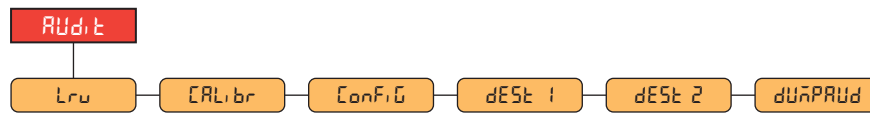

Figure 4-3. Audit Menu

Parameter	Description
Lrv	LRV – Legally relevant firmware version
CALibr	Calibration – Displays total number of calibration events (read only)
ConFIG	Configuration – Displays total number of configuration events (read only)
dESt 1	Destination Port 1 – Audit trail port; Settings: <b>RS232-1</b> (default), RS232-2, TCPC, TCPS, WIFI/BT, USB, NONE
dESt 2	Destination Port 2 – Audit trail port; Settings: <b>NONE</b> (default), RS232-1, RS232-2, TCPC, TCPS, WIFI/BT, USB
dUñPRUD	Dump Audit Trail – Sends the audit values to the configured print port(s)

Table 4-2. Audit Menu Descriptions

### 4.4 Setup Menu



Figure 4-4. Setup Menu

Menu	Description
ConFIG	Configuration – See <a href="#">Section 4.4.1 on page 30</a> for menu structure and parameter descriptions of the Configuration menu
ForñARt	Format – See <a href="#">Section 4.4.2 on page 31</a> for menu structure and parameter descriptions of the Format menu
CALibr	Calibration – See <a href="#">Section 4.4.3 on page 32</a> for menu structure and parameter descriptions of the Calibration menu
Coññ	Communication – See <a href="#">Section 4.4.4 on page 33</a> for menu structure and parameter descriptions of the Communication menu
SForñARt	Stream Format – See <a href="#">Section 4.4.5 on page 36</a> for menu structure and parameter descriptions of the Stream Format menu
PForñARt	Print Format – See <a href="#">Section 4.4.6 on page 36</a> for menu structure and parameter descriptions of the Print Format menu
ProGRñ	Program – See <a href="#">Section 4.4.7 on page 37</a> for menu structure and parameter descriptions of the Program menu
diG io	Digital I/O – See <a href="#">Section 4.4.8 on page 39</a> for menu structure and parameter descriptions of the Digital I/O menu
dFLtCFG	Default Configuration – See <a href="#">Section 3.4.9 on page 27</a> for instructions to reset the configuration settings

Table 4-3. Setup Menu Descriptions

### 4.4.1 Setup – Configuration Menu

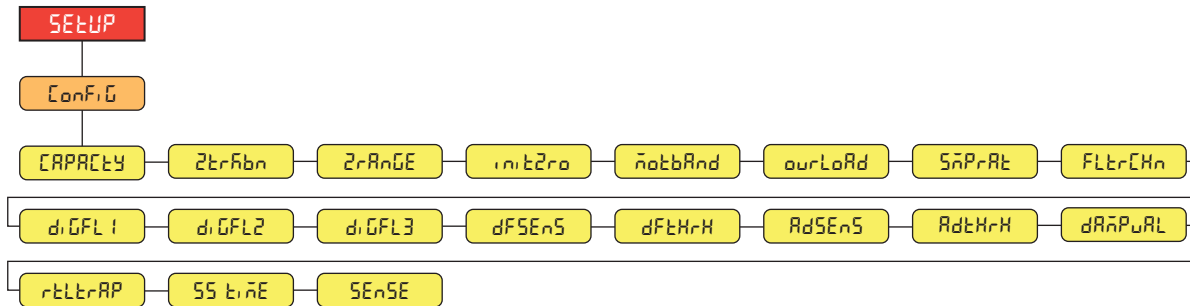

Figure 4-5. Setup – Configuration Menu

Menu	Description
CAPACITY	Capacity – Maximum rated capacity of the scale; <i>Enter value: 0.0000001–9999999.0, 500.0 (default)</i>
Zero Track Band	Zero Track Band – Automatically zeros the scale when within the range specified, as long as the input is within the Zero Range and scale standstill; When weight is within the zero band, the center of zero annunciator displays; Max legal value depends on local regulations; Specify the zero tracking band in $\pm$ display divisions; <i>Enter value: 0.0–100.0, 0.0 (default)</i>
Zero Range	Zero Range – The total amount the scale can be zeroed; Zero range represents a percentage of capacity; The default value of 1.9 represents $\pm 1.9\%$ around the calibrated zero point, for a total range of 3.8%; A value of 0.0 prevents zeroing; Maximum legal value depends on local regulations; <i>Enter value: 0.0–100.0, 1.9 (default)</i>
Initial Zero	Initial Zero Range – When the indicator is turned on and the weight value is between the $\pm$ percent range specified in Calibrated Zero, the indicator automatically zeros off the weight; <i>Enter value: 0.0–100.0, 0.0 (default)</i>
Motion Band	Motion Band – Sets the level, in display divisions, at which scale motion is detected; If motion is not detected for the time defined by SS t.rE, the standstill symbol lights; Some operations, including print and zero, require the scale to be at standstill; Maximum legal value varies depending on local regulations; If this parameter is set to 0, the standstill annunciator is always lit and operations requiring standstill are performed regardless of scale motion; If 0 is selected, Zero Track Band must also be set to 0; <i>Enter value: 0–100, 1 (default)</i>
Overload	Overload – Determines the point at which the display blanks and the overload error message displays (^^^^^^); Maximum legal value varies depending on local regulations; <i>Settings: FS+2% (default), FS+1D, FS+9D, FS</i>
Sample Rate	Sample Rate – Selects measurement rate, in samples per second, of the analog-to-digital converter; Lower sample rate values provide greater signal noise immunity; <i>Settings: 6.25HZ, 7.5HZ, 12.5HZ, 15HZ, 25HZ, 30HZ (default), 50HZ, 60HZ, 100HZ, 120HZ</i>
Filter Chain	Filter Chain Type – Sets the filter type to be used; <i>Settings:</i> <b>AVGONLY</b> (default) – Digital Rolling Average Filter; Uses DIGFL1-3, DSENS and DFTHR ADPONLY – Adaptive Filter; Uses ADSENS and ADTHR DMPONLY – Damping Filter; Uses DMPVAL RAW – No filtering
DIGFL 1-3	Digital Filters – Sets the digital filtering rate used to reduce the effects of environmental influences from the immediate area of the scale; Settings indicate the number of A/D conversions per update which are averaged to obtain the displayed reading; a higher number gives a more accurate display by minimizing the effect of a few noisy readings, but slows down the response time of the indicator; <i>Settings: 1, 2, 4, 8, 16, 32 (default), 64, 128, 256</i>
DSENS	Digital Filter Sensitivity – Specifies the number of consecutive A/D readings which fall outside the Filter Threshold before filtering is suspended; <i>Settings: 2OUT (default), 4OUT, 8OUT, 16OUT, 32OUT, 64OUT, 128OUT</i>
DFTHR	Digital Filter Threshold – Sets a threshold value, in display divisions; when a number of consecutive A/D readings (Digital Filter Sensitivity) falls outside of this threshold value (when compared to the output of the filter), filtering is suspended and the A/D value is sent straight through the filter; Filtering is not suspended if the threshold is set to NONE; <i>Settings: NONE, 2D, 5D (default), 10D, 20D, 50D, 100D, 200D, 250D</i>
ADSENS	Adaptive Filter Sensitivity – Controls the stability and response time of the scale; <i>Settings:</i> <b>LIGHT</b> (default) – Fastest response to small weight changes, but less stable <b>MEDIUM</b> – Has a quicker response time than heavy, but more stable than light <b>HEAVY</b> – Results in an output which is more stable but settles slowly; small changes in weight data (a few grads) on the scale base are not seen quickly
ADTHR	Adaptive Filter Threshold – Sets the adaptive filter weight threshold value (in display divisions); a weight change exceeding the threshold resets the filtered values; must be set above the noise disturbances in the system (if set to zero, the filter is disabled); <i>Enter value: 0–2000, 10 (default)</i>

Table 4-4. Setup – Configuration Menu Descriptions

Menu	Description
dRĀPĀRL	Damping Value – Sets the damping time constant (in 0.1 sec intervals); <i>Enter value: 0–2560, 10 (default)</i>
rĒLĒrĀP	RattleTrap – Enables RattleTrap filtering; Effective at eliminating vibration effects, environmental influences and mechanical interference from nearby machinery, may increase response time over standard digital filtering; <i>Settings: OFF (default), ON</i>
55 ĒĀĒ	Standstill Time – Specifies the length of time the scale must be out of motion, before the scale is considered to be at standstill (in 0.1 sec intervals); <i>Enter value: 0–600, 10 (default)</i>
5ĒĀ5Ē	Sense – Specifies the type of load cell cable connected to the J1 connector; <i>Settings: 4-WIRE (default), 6-WIRE</i>

Table 4-4. Setup – Configuration Menu Descriptions (Continued)

## 4.4.2 Setup – Format Menu

### 4.4.2.1 Primary and Secondary Menus

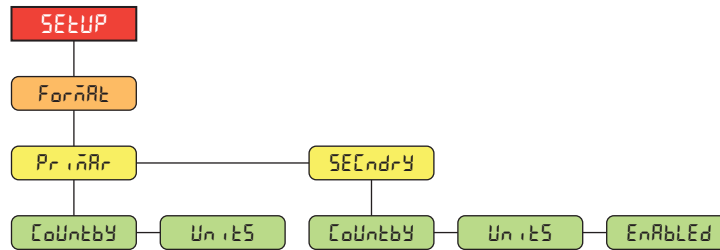

Figure 4-6. Format – Primary and Secondary Menus

Parameter	Description
Countby	Countby – Sets the decimal point and the display divisions for the Primary (PrĀrĀ) and Secondary (5ĒĒĒrĀ) display weight format; For example, select 8888.885 if a count by of 0.005 is needed or select 8888820 if a count by of 20 is needed (the 8s serve as placeholders and show a breakdown of how digits will display); <i>Settings: 888881 (Primary default), 888882, 888885, 8888810, 8888820, 8888850, 8888100, 8888200, 8888500, 88.88881, 88.88882, 88.88885, 888.8881, 888.8882, 888.8885, 8888.881, 8888.882, 8888.885, 88888.81, 88888.82, 88888.85, 88888.1, 888888.2, 888888.5 (Secondary default)</i>
Units	Units – Sets the units type; <i>Settings: LB (Primary default), KG (Secondary default)</i>
Enabled	Enabled – Enables the remote keypad <b>UNITS</b> key to toggle between the primary and secondary formats (only displays under Secondary); <i>Settings: ON (default), OFF</i>

Table 4-5. Format – Primary and Secondary Menu Parameters

### 4.4.3 Setup – Calibration Menu

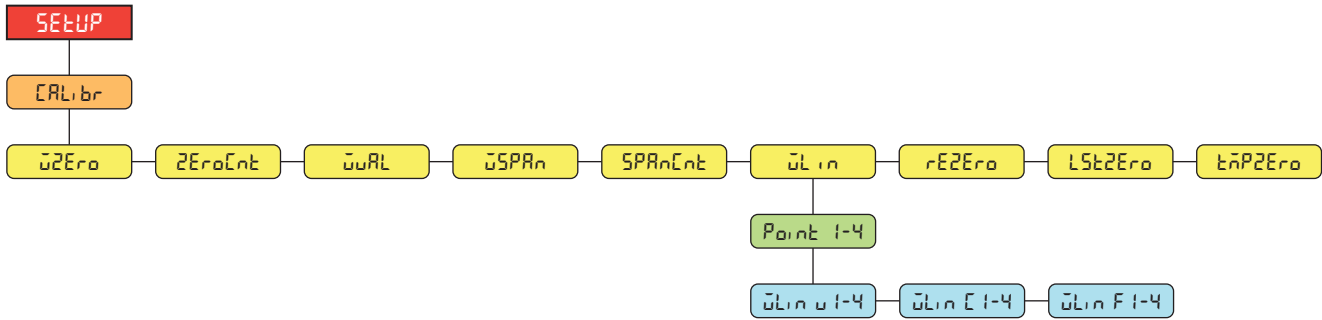

Figure 4-7. Setup – Calibration Menu

Parameter	Description
WZERO	Zero Calibration – Executes the zero calibration process; See <a href="#">Section 5.1 on page 40</a>
ZEROCount	Zero Calibration Count – Displays the raw count value at the zero weight; A zero calibration (WZERO) generates this raw count value; Manually changing this count value changes the zero weight and negates the zero calibration
WWT	Test Weight Value – Sets the weight value for the span calibration; See <a href="#">Section 5.1 on page 40</a> ; Enter value: 0.000001–9999999.999999, <b>500.0</b> (default)
WSPAN	Span Calibration – Executes the span calibration process; See <a href="#">Section 5.1.1 on page 40</a>
SPANCount	Span Calibration Count – Displays the raw count value at the span weight; A span calibration (WSPAN) generates this raw count value; Manually changing this count value changes the span weight and negates the span calibration
WLIN	Linear Calibration – A linear or multi-point calibration is performed by entering up to four additional calibration points; See <a href="#">Section 5.1.2 on page 41</a> WLIN V# – Sets the test weight value for linear calibration point WLIN C# – Executes the linear calibration process for the point; generates the raw count value (F) for the test weight value (V) WLIN F# – Displays the raw count value at the linear point weight; A linear calibration (WLIN C#) generates this raw count value; Manually changing this count value changes the linear point weight and negates the linear calibration for the point
REZERO	Rezero – Removes an offset value from the zero and span calibrations; See <a href="#">Section 5.2.3 on page 41</a>
LASTZERO	Last Zero – Takes the last pushbutton zero in the system (from weigh mode) and uses it as the new zero reference point, after which a new span calibration must be performed; This calibration cannot be performed when calibrating a scale for the first time; See <a href="#">Section 5.2.1 on page 41</a>
TEMPZERO	Temporary Zero – Temporarily zeros the displayed weight of a non-empty scale, after a span calibration was performed; The difference between the temporary zero and the previously calibrated zero value is used as an offset; See <a href="#">Section 5.2.2 on page 41</a>

Table 4-6. Setup – Calibration Menu Parameter



### 4.4.4 Setup – Communication Menu

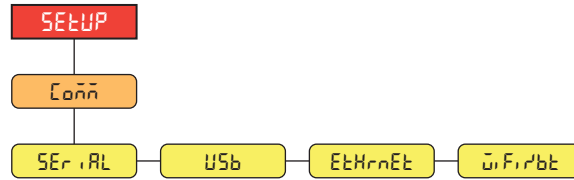

Figure 4-8. Setup – Communication Menu

Menu	Description
SERIAL	Serial Port – Supports RS-232 full duplex to host serial communications; See <a href="#">Section 4.4.4.1</a>
USB	USB – Intended to be connected to a PC only; appears as a Virtual COM Port and is assigned a “COMx” designation; applications communicate through the port like a standard RS-232 communications port; See <a href="#">Section 4.4.4.2 on page 34</a>
Ethernet	Ethernet – Features Ethernet TCP/IP 10Base-T/100Base-TX communication and can support two simultaneous connections, one as a server, the other as a client; See <a href="#">Section 4.4.4.3 on page 34</a>
Wi-Fi/Bt	Wi-Fi/Bluetooth® – Supports Wi-Fi and Bluetooth® communications; See <a href="#">Section 4.4.4.4 on page 35</a>

Table 4-7. Setup – Communication Menu Descriptions

#### 4.4.4.1 Serial Port Menu

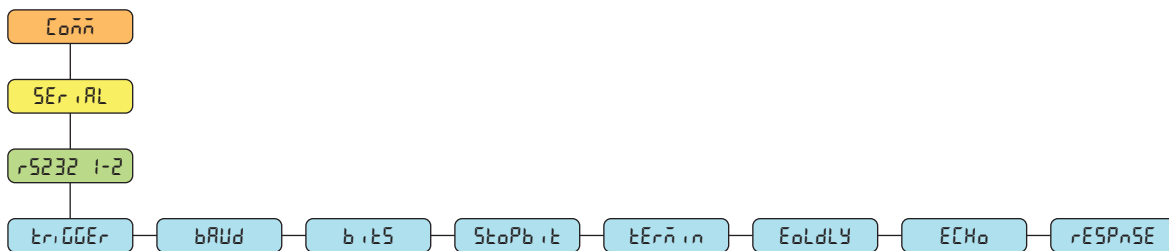

Figure 4-9. Communication – Serial Port Menu

Parameter	Description
trIGGER	Trigger – Sets the input trigger type; <i>Settings:</i> <b>CMD</b> (default) – Command: allows operation of EDP commands and printing <b>STRIND</b> – Stream Industrial Scale Data: data is updated up to the configured sample rate; allows operation of EDP commands and printing <b>STRLFT</b> – Stream Legal for Trade Data: data is updated at the configured display update rate; allows operation of EDP commands and printing
baud	Baud Rate – Sets the transmission speed for the port; <i>Settings:</i> 1200, 2400, 4800, <b>9600</b> (default), 19200, 28800, 38400, 57600, 115200
bits	Data Bits – Sets number of data bits transmitted or received by the port and specifies the parity bit to odd, even or none; <i>Settings:</i> <b>8NONE</b> (default), 7EVEN, 7ODD
Stopbits	Stop Bits – Sets the number of stop bits transmitted or received by the port; <i>Settings:</i> <b>1</b> (default), 2
Termin	Outgoing Line Termination – Sets the termination character for data sent from the port; <i>Settings:</i> <b>CR/LF</b> (default), CR
EoLDLY	End of Line Delay – Sets the delay period from when a formatted line is terminated to the beginning of the next formatted serial output (measured in 0.1 second intervals); a value of 10 equals 1 second; <i>Enter value:</i> 0–255, <b>0</b> (default)
ECHO	Echo – Specifies if characters received by the port are echoed back to the sending unit; <i>Settings:</i> <b>ON</b> (default), OFF
rESPnSE	Response – Specifies if the port transmits replies to serial commands; <i>Settings:</i> <b>ON</b> (default), OFF

Table 4-8. Communication – Serial Port Menu Parameters

### 4.4.4.2 USB Menu

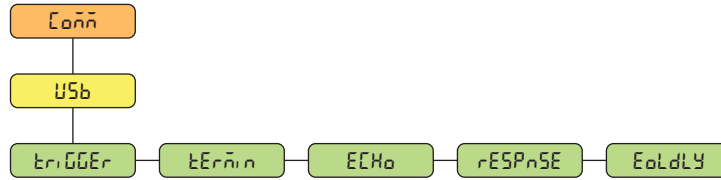

Figure 4-10. Communication – USB Menu

Parameter	Description
TRIGGER	Trigger – Sets the input trigger type; Settings: <b>CMD</b> (default) – Command: setting input trigger to command allows operation of EDP commands and printing <b>STRIND</b> – Stream Industrial Scale Data: data is updated up to the configured sample rate; allows operation of EDP commands and printing <b>STRLFT</b> – Stream Legal for Trade Data: data is updated at the configured display update rate; allows operation of EDP commands and printing
Termin	Outgoing Line Termination – Sets the termination character for data sent from the port; Settings: <b>CR/LF</b> (default), CR
Echo	Echo – Specifies if characters received by the port are echoed back to the sending unit; Settings: <b>ON</b> (default), OFF
RESPONSE	Response – Specifies if the port transmits replies to serial commands; Settings: <b>ON</b> (default), OFF
EoLDLY	End of Line Delay – Sets the delay period from when a formatted line is terminated to the beginning of the next formatted serial output (measured in 0.1 second intervals); a value of 10 equals 1 second; Enter value: 0–255, <b>0</b> (default)

Table 4-9. Communication – USB Menu Parameters

### 4.4.4.3 Ethernet Menu

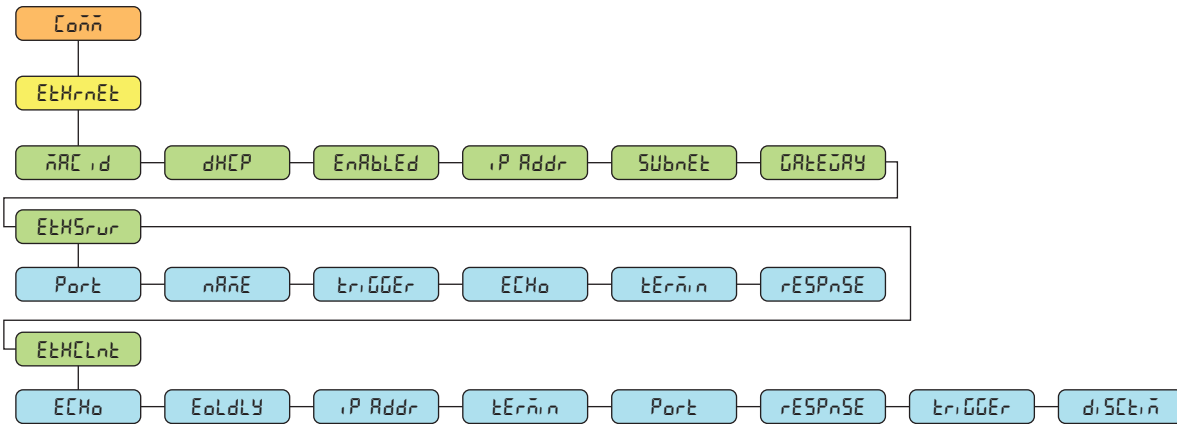

Figure 4-11. Communication – Ethernet Menu

Parameter	Description
MAC ID	Wired MAC ID – Read only; Settings: 00:00:00:00:00:00
DHCP	DHCP – Dynamic Host Configuration Protocol (static allocation of IP address when OFF); Settings: <b>ON</b> (default), OFF
ENABLED	Enabled – Enables Ethernet communications; Settings: <b>OFF</b> (default), ON
IP Addr	IP Address; Enter value: 0.0.0.0
SUBNET	Subnet Mask; Enter value: 255.255.255.0
GATEWAY	Default Gateway; Enter value: 0.0.0.0

Table 4-10. Communication – Ethernet Menu Parameters

Parameter	Description
EETHER	Ethernet Server – Allows the Tracer AV2 to receive external EDP commands; <i>Sub-parameters:</i> PORT – Specifies IP Address port to open to establish communications; <i>Enter value: 1025–65535, 10001 (default)</i> NAME – Host name for Ethernet Server; <i>Enter characters: Alphanumeric entry up to 30 characters, 0 (default)</i> TRIGGER – Sets the input trigger type; <i>Settings: CMD (default), STRIND, STRLFT</i> ECHO – Specifies if characters received by the port are echoed back to the sending unit; <i>Settings: OFF (default), ON</i> TERMIN – Line Termination: Sets the termination character for data sent from the port; <i>Settings: CR/LF (default), CR</i> RESPONSE – Specifies if the port transmits replies to serial commands; <i>Settings: ON (default), OFF</i>
EETHERC	Ethernet Client – Allows the Tracer AV2 to send EDP commands to external devices; <i>Sub-parameters:</i> ECHO – Specifies if characters received by the port are echoed back to the sending unit; <i>Settings: ON (default), OFF</i> EOLDLY – End of Line Delay: Sets the delay period from when a formatted line is terminated to the beginning of the next formatted serial output (measured in 0.1 second intervals); a value of 10 equals 1 second; <i>Enter value: 0–255, 0 (default)</i> IP ADDR – IP Address; <i>Enter value: 0.0.0.0</i> TERMIN – Line Termination: Sets the termination character for data sent from the port; <i>Settings: CR/LF (default), CR</i> PORT – Specifies IP Address port to look for to establish communications; <i>Enter value: 1025–65535, 10001 (default)</i> RESPONSE – Specifies if the port transmits replies to serial commands; <i>Settings: ON (default), OFF</i> TRIGGER – Sets the input trigger type; <i>Settings: CMD (default), STRIND, STRLFT</i> DISCTIM – Disconnect Timeout (in seconds); <i>Enter value: 0–60, 0 (default)</i>

Table 4-10. Communication – Ethernet Menu Parameters (Continued)

#### 4.4.4.4 Wi-Fi/Bluetooth® Menu

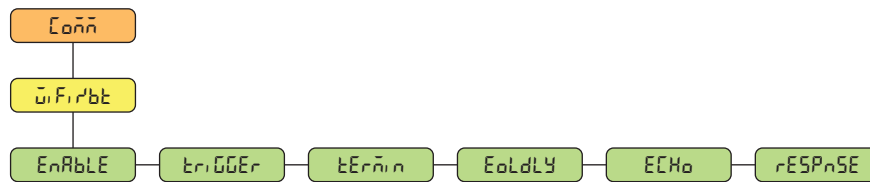

Figure 4-12. Communication – Wi-Fi/BT Menu

Parameter	Description
EnRbLE	Enable – Enables the wireless module and specifies Wi-Fi or Bluetooth® communication; <i>Settings: OFF (default), WIFI, BTOOTH</i>
tRiGGEr	Trigger – Sets the input trigger type; <i>Settings:</i> <b>CMD</b> (default) – Command: setting input trigger to command allows operation of EDP commands and printing STRIND – Stream Industrial Scale Data: data is updated up to the configured sample rate; allows operation of EDP commands and printing STRLFT – Stream Legal for Trade Data: data is updated at the configured display update rate; allows operation of EDP commands and printing
tErMiN	Outgoing Line Termination – Sets the termination character for data sent from the port; <i>Settings: CR/LF (default), CR</i>
EoLdLY	End of Line Delay – Sets the delay period from when a formatted line is terminated to the beginning of the next formatted serial output (measured in 0.1 second intervals); a value of 10 equals 1 second; <i>Enter value: 0–255, 0 (default)</i>
ECHO	Echo – Specifies if characters received by the port are echoed back to the sending unit; <i>Settings: ON (default), OFF</i>
rESPnSE	Response – Specifies if the port transmits replies to serial commands; <i>Settings: ON (default), OFF</i>

Table 4-11. Communication – Wi-Fi/BT Menu Descriptions

### 4.4.5 Setup – Stream Format Menu

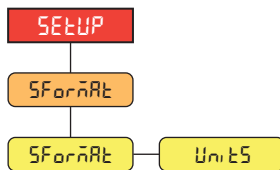

Figure 4-13. Setup – Stream Format Menu

Parameter	Description
SForARt	Stream Format – Specifies the stream format used for streaming output of scale data or specifies the expected input for a serial scale; <i>Settings:</i> <b>RLWS</b> (default) – Rice Lake Weighing Systems stream format; See <a href="#">Section 11.5.1 on page 64</a> <b>CARDNAL</b> – Cardinal stream format; See <a href="#">Section 11.5.2 on page 65</a> <b>WTRONIX</b> – Avery Weigh-Tronix stream format; See <a href="#">Section 11.5.3 on page 65</a> <b>TOLEDO</b> – Mettler Toledo stream format; See <a href="#">Section 11.5.4 on page 66</a>
UNtS	Units - Determines the source for the Units character sent in the RLWS stream format. Static (default) - L is sent for Primary Units, K is sent for Secondary Units. Dynamic - L is sent if displaying pounds, K is sent if displaying kilograms, no matter if primary or secondary.

Table 4-12. Setup – Stream Format Menu Parameters

### 4.4.6 Setup – Print Format Menu

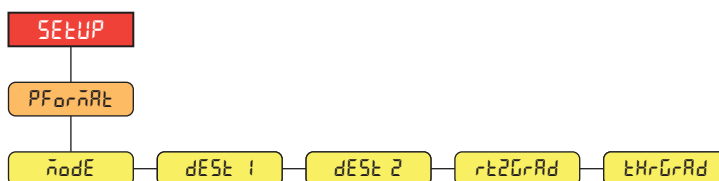

Figure 4-14. Setup – Print Format Menu

Parameter	Description
ModE	Mode – Print format modes; <i>Settings:</i> <b>STANDRD</b> (default) – Standard printing mode using the <b>PRINT</b> key; prints the transaction number and the gross weight <b>AUTO</b> – Automatic printing mode causes a ticket to be printed automatically when the following conditions are met: <ul style="list-style-type: none"> <li>• The weight is currently at or above the <b>THRGARD</b> value</li> <li>• The scale has reached a stable weight</li> <li>• The weight must return to the <b>RTZGRAD</b> value or below before subsequent automatic prints may occur</li> </ul> <b>MULTI</b> – Multiple printing mode enables the <b>ACCUM</b> key print function; each time the <b>ACCUM</b> key is pressed, a new weighment is added to the total; pressing the <b>PRINT</b> key prints the current number of weighments with the current total weight and closes out the current transaction; the same conditions as <b>AUTO</b> must be met for <b>MULTI</b>
dEst 1	DEST 1 – Destination port 1; <i>Settings:</i> <b>RS232-1</b> (default), RS232-2, TCPC, TCPS, WIFI/BT, USB, NONE
dEst 2	DEST 2 – Destination port 2; <i>Settings:</i> <b>NONE</b> (default), RS232-1, RS232-2, TCPC, TCPS, WIFI/BT, USB
rTzGRAd	RTZGRAD – Return to zero graduation value; only available when <b>AUTO</b> and <b>MULTI</b> printing modes are selected; hidden in <b>STNDRD</b> mode; <i>Enter value:</i> 0-9999999, <b>0</b> (default)
tHrGRAd	THRGRAD – Threshold graduation value; only available when <b>AUTO</b> and <b>MULTI</b> printing modes are selected; hidden in <b>STNDRD</b> mode; <i>Enter value:</i> 0-9999999, <b>10</b> (default)

Table 4-13. Setup – Print Format Menu Parameters

### 4.4.7 Setup – Program Menu

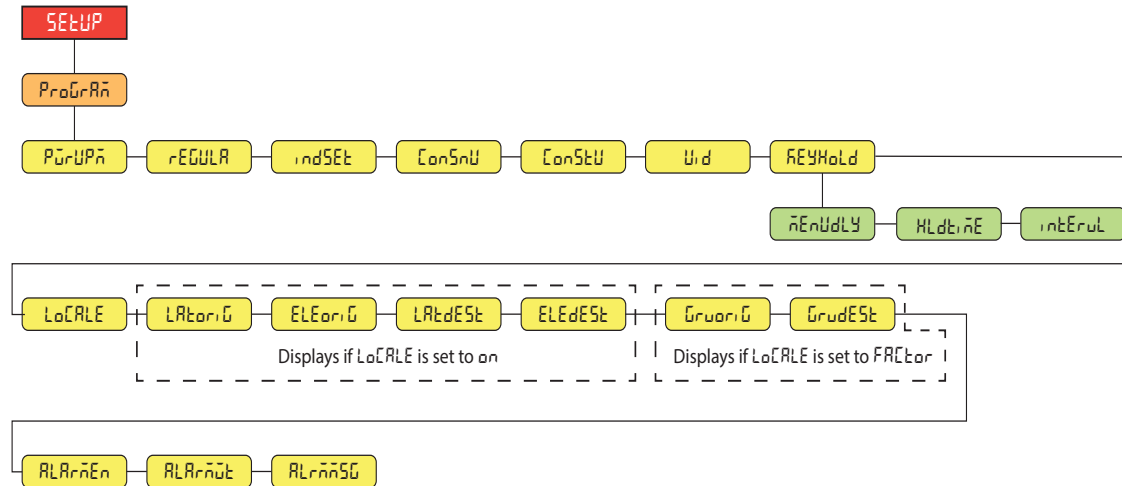

Figure 4-15. Setup – Program Menu

Parameter	Description
PwrUPn	Power Up Mode – When the indicator is turned on, it performs a display test, then enters a warm up period; <i>Settings:</i> <b>GO</b> (default) – Performs display test, then enters weigh mode after brief warm up period <b>DELAY</b> – Performs display test, then enters a warm up period of 30 seconds <ul style="list-style-type: none"> <li>• If no motion is detected during warm up period, indicator enters weigh mode when warm up period ends</li> <li>• If motion is detected, the 30 second timer is reset and the warm up period is repeated</li> </ul>
REGULA	Regulatory Mode – Specifies the regulatory agency having jurisdiction over the scale site; the value specified for this parameter affects the function of the keypad <b>ZERO</b> key; <i>Settings:</i> <b>NTEP</b> (default), <b>OIML</b> , <b>CANADA</b> , <b>INDUST</b> , <b>NONE</b> <ul style="list-style-type: none"> <li>• NONE, NTEP and CANADA modes allow the scale to be zeroed as long as the current weight is within the specified ZRANGE; In OIML mode, the scale must be in gross mode before it can be zeroed</li> <li>• INDUST provides a set of sub-parameters to allow function customization in non-Legal for Trade scale installations</li> </ul>
INDSET	Industrial Settings – Displays when REGULA parameter is set to INDUST; See <a href="#">Section 4.4.7.1 on page 38</a>
CONSNU	Consecutive Numbering – Allows sequential numbering for print operations; the value is incremented following each print operation which includes <CN> in the ticket format; <i>Enter value:</i> 0–9999999, <b>0</b> (default)
CONSNU	Consecutive Number Startup Value – Specifies the initial consecutive number (CONSNU) value used when the consecutive number is reset by sending CLEARCN digital input; <i>Enter value:</i> 0–9999999, <b>0</b> (default)
UID	Unit ID – Specifies the unit identification number with an alphanumeric value; <i>Enter characters:</i> Up to 6 alphanumeric characters, <b>1</b> (default)
KEYHOLD	Key Hold – Allows setting of the key hold time and interval <b>MENDLY</b> - The amount of time (in seconds) the Enter key must be held to access the user menu; <i>Enter Value:</i> 0–30, <b>10</b> (default) <b>HLDTIME</b> – Key hold time (in tenths of a second); how long a key needs to be held before a key hold action is initiated; 20 equals 2 seconds; <i>Enter value:</i> 10–50, <b>20</b> (default) <b>INTERVL</b> – Key hold time interval (in twentieths of a second); the amount of time between increments during a key hold; 2 equals a tenth of a second (10 increments per second during a key hold); <i>Enter value:</i> 1–100, <b>2</b> (default)
LOCALE	Location Gravity Compensation – Enables gravity compensation; <i>Settings:</i> <b>OFF</b> (default) – gravity compensation disabled <b>ON</b> – calculates gravity compensation using the origin and destination latitudes and elevations <b>FACTOR</b> – uses origin and destination gravity factors to find gravity compensation
LATORIG	Latitude Origin – Original latitude (to nearest degree) for gravity compensation; displays when LOCALE parameter is set to ON; <i>Enter value:</i> 0–90, <b>45</b> (default)
ELEVORIG	Elevation Origin – Original elevation (in meters) for gravity compensation; displays when LOCALE parameter is set to ON; <i>Enter value:</i> -9999–9999, <b>345</b> (default)
LATDEST	Latitude Destination – Destination latitude (to nearest degree) for gravity compensation; displays when LOCALE parameter is set to ON; <i>Enter value:</i> 0–90, <b>45</b> (default)

Table 4-14. Setup – Program Menu Parameters

Parameter	Description
ELdESEt	Elevation Destination – Destination elevation (in meters) for gravity compensation; displays when LOCALE parameter is set to ON; Enter value: -9999–9999, <b>345</b> (default)
GravOrIG	Gravity Origin – Original gravity factor (in m/s <sup>2</sup> ) for gravity compensation; displays when LOCALE parameter is set to FACTOR; Enter value: 9.00000–9.99999, <b>9.80665</b> (default)
GravdESEt	Gravity Destination – Destination gravity factor (in m/s <sup>2</sup> ) for gravity compensation; displays when LOCALE parameter is set to FACTOR; Enter value: 9.00000–9.99999, <b>9.80665</b> (default)
ALRnEn	Alarm Enable – Enables alarm, scrolls a message across display when set weight value is exceeded; Settings: ON, <b>OFF</b> (default)
ALRnWt	Alarm Weight Value – Sets the weight value at which alarm is tripped; Enter value: 0.000001–9999999, <b>50</b> (default)
ALRnMSG	Alarm Message – Sets the alarm message that displays when the alarm is tripped; Enter characters: Up to 20 alphanumeric characters, <b>OVERWEIGHT</b> (default)

Table 4-14. Setup – Program Menu Parameters (Continued)

### 4.4.7.1 Industrial Settings Menu

The industrial settings menu (INDSET) only displays if the regulation parameter (REGULR) is set to industrial (INDUST).

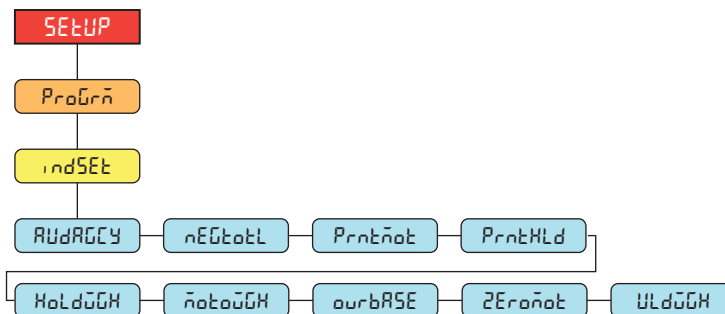

Figure 4-16. Industrial Settings Menu

Parameter	Description
AUDAGCY	Audit Agency – Audit trail display agency format; Settings: <b>NTEP</b> (default), CANADA, NONE, OIML
NEGtotL	Negative Total – Allow total scale to display negative value; Settings: <b>NO</b> (default), YES
PrntInot	Print In Motion – Allow print while in motion; Settings: <b>NO</b> (default), YES
PrntHLd	Print Hold – Print during display hold; Settings: <b>NO</b> (default), YES
HoldWtGH	Hold Weighment – Allow weighment during display hold; Settings: <b>NO</b> (default), YES
MotWtGH	Motion Weighment – Allow weighment in motion; Settings: <b>NO</b> (default), YES
OverbRSE	Overload Base – Zero base for overload calculation; Settings: <b>CALIB</b> (default), SCALE
ZeroInot	Zero In Motion – Allow scale to be zeroed while in motion; Settings: <b>NO</b> (default), YES
ULdWtGH	Underload Weight – Underload weight value in display divisions; Enter value: 1–9999999, <b>20</b> (default)

Table 4-15. Industrial Settings Menu Parameters

#### 4.4.8 Setup – Digital I/O Menu

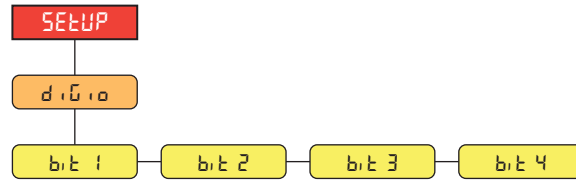

Figure 4-17. Setup – Digital I/O Menu

Parameter	Description
bit 1-4	Digital I/O Bit 1-4 – Specifies the mode and function of the digital I/O pins; <i>Settings: OFF (default), PRINT, ACCUM, ZERO, UNITS, PRIM, SEC, CLEAR, CLEARCN, KBDLOC, OUTPUT</i>

Table 4-16. Setup – Digital I/O Menu Parameters

#### 4.5 MAC ID Menu



Figure 4-18. MAC ID Menu

Menu	Description
wired	Wired – Displays the wired Ethernet MAC Address (read only)
Wi-Fi	Wi-Fi – Displays the Wi-Fi MAC Addresses (read only)
bluetooth	Bluetooth® – Displays the Bluetooth® MAC Addresses (read only)

Table 4-17. MAC ID Menu Descriptions

## 5.0 Calibration

The Tracer AV2 can be calibrated using the remote keypad or EDP commands. The following sections describe the procedures required for these calibration methods.

**NOTE:** The Tracer AV2 requires WZERO and WSPAN points to be calibrated. The linear calibration points (WLIN) are optional; they must fall between zero and span, but must not duplicate zero or span.

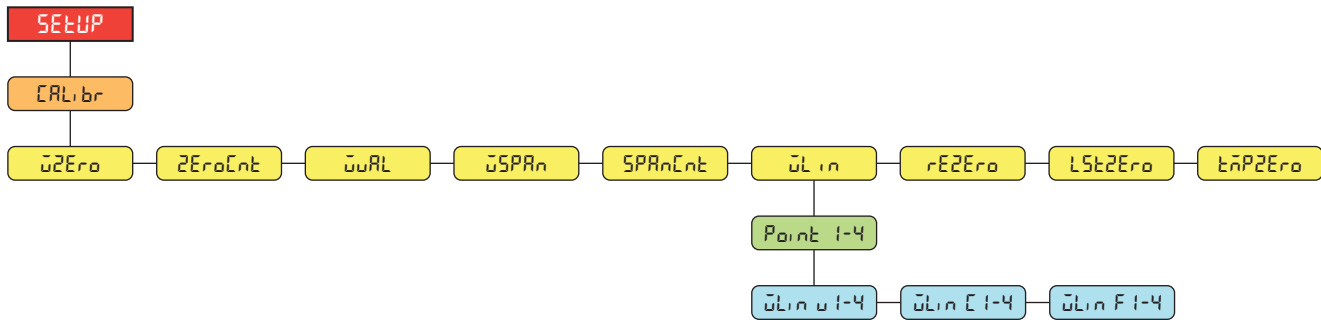

Figure 5-1. Calibration Menu

### 5.1 Keypad Calibrations

#### 5.1.1 Span Calibration

Use the following steps to perform a span calibration on a connected scale. Calibration requires access to setup mode.

1. Access the setup menu by pressing the setup switch (Section 4.1 on page 28). `CONF` displays.
2. Press twice. `CALibr` displays.
3. Press . `WZERO` displays.

**NOTE:** See Section 5.2 on page 41 if the application requires a rezero, last zero or temporary zero.

4. Ensure there is no weight on the scale.
5. Press to perform a zero calibration. `oF` displays.
6. Press . `ZEROEnt` displays. See Section 4.4.3 on page 32 for more information on `ZEROEnt`.
7. Press . `WRL` displays.
8. Press . The current test weight value displays.
9. Use the numeric value entry procedure to enter a new value (Section 3.3.1 on page 24), if necessary.
10. Press to accept value. `WSPRn` displays.
11. Place the specified amount of test weight on the scale.
12. Press to perform a span calibration. `oF` displays.
13. Press . `SPRnEnt` displays. See Section 4.4.3 on page 32 for more information on `SPRnEnt`.









**NOTE:** Span calibration is complete. To continue with a linear calibration, see Section 5.1.2 on page 41 before returning to weigh mode.

14. Press three times to return to weigh mode.



## 5.1.2 Linear Calibration

Linear calibration points provide increased scale accuracy by calibrating the indicator at up to four additional points between the zero and span calibrations. Calibration requires access to setup mode.

1. Complete [steps 1–13 in Section 5.1.1 on page 40](#). Press .  $\bar{L}IN$  displays.
2. Press .  $P_{01}$  displays.
3. Press .  $\bar{L}IN$  displays.
4. Press . The current test weight value for point 1 displays.
5. Use the numeric value entry procedure to enter a new value ([Section 3.3.1 on page 24](#)), if necessary.
6. Press  to accept value.  $\bar{L}IN$  displays.
7. Place the specified amount of test weight on the scale.
8. Press  to perform a linear point calibration.  $\bar{L}IN$  displays.
9. Press .  $\bar{L}IN$  F# displays. See [Section 4.4.3 on page 32](#) for more information on WLIN F#.
10. Press .  $P_{01}$  displays.
11. Press .  $P_{02}$  displays.
12. Repeat previous steps for points 2-4, if necessary.



**NOTE:** The linear calibration for a point is saved once the point is calibrated.

13. Press  multiple times to return to weigh mode.

## 5.2 Alternative Zero Calibrations

During a calibration, the zero value ( $\bar{Z}ERO$ ) can be replaced with a temporary zero ( $\bar{T}EMP$ ) or last zero ( $\bar{L}AST$ ). A rezero ( $\bar{R}EZO$ ) can be done after calibration. See below for information on these alternative zeros.

### 5.2.1 Last Zero

This takes the last push-button zero in the system (from weigh mode) and uses it as the new zero reference point, after which a new span calibration must be performed. This calibration cannot be performed when calibrating a scale for the first time.

A last zero calibration is typically used on truck scales to allow a scale verification to become a calibration without having to remove the test weights.

### 5.2.2 Temporary Zero

A temporary zero calibration temporarily zeros the displayed weight of a non-empty scale. After span calibration, the difference between the temporary zero and the previously calibrated zero value is used as an offset.

A temporary zero calibration is typically used on hopper scales to calibrate the span without losing the original zero calibration.

### 5.2.3 Rezero

A rezero calibration is needed to remove a calibration offset when hooks or chains are required to suspend the test weights.

Once a span calibration is complete, remove the hooks or chains and the test weights from the scale. With all the weight removed, a rezero calibration is used to adjust the zero and span calibration values.

### 5.3 EDP Command Calibration

Use the following instructions to calibrate the Tracer AV2 using EDP commands. Calibration requires access to setup mode.



**NOTE:** The indicator must respond with **OK** after each step or the calibration procedure must be done again.

1. Press the setup switch to place indicator in setup mode ([Section 4.1 on page 28](#)).
2. For a standard calibration, remove all weight from scale (except hooks or chains which are needed to attach weights).
3. Send the command **SC.WZERO#1** to perform a standard calibration of the zero point.
  - Send **SC.TEMPZERO#1** to perform a temporary zero calibration
  - Send **SC.LASTZERO#1** to perform a last zero calibration
4. Apply the span calibration weight to the scale.
5. Send the command **SC.WVAL#1=xxxxx**, where **xxxxx** is the value of the span calibration weight applied to the scale.
6. Send the command **SC.WSPAN#1** to calibrate the span point. Continue on to [step 7](#) to calibrate additional linear calibration points, or proceed to [step 11](#).
7. Apply weight equal to the first linear calibration point to the scale.
8. Send the command **SC.WLIN.Vn#1=xxxxx**, where **n** is the linear calibration point number (1-4) and **xxxxx** is the exact value of the weight applied.
9. Send the command **SC.WLIN.Cn#1** to calibrate the linear calibration point, where **n** is the linear calibration point number (1-4).
10. Repeat [steps 7–9](#) for up to four linear calibration points.
11. If hooks or chains were used to attach the weights, remove all weight, including the hooks and chains, and send the command **SC.REZERO#1** to remove the zero offset.
12. Send the command **KSAVEEXIT** to return to weigh mode.

## 6.0 Wi-Fi Configuration

The Tracer AV2 is a Wi-Fi or Bluetooth® device. The Tracer AV2 creates a Wi-Fi network that can be connected to with a computer or the location's network. Configuration of the wireless settings is done through the built-in Web Manager. The Web Manager can be accessed through the built-in Soft AP (Access Point) and by default, the Soft AP is available any time the unit is powered up.

The Soft AP can be used to connect to a location's network using the Web Manager. In applications that don't have a local network to connect to or if the network is not in range, the Soft AP connection can also be used to talk to a Tracer AV2 by connecting to IP 192.168.0.1, port 10001.

The Tracer AV2 features a Lantronix® xPico 200 Series wireless module. Visit [www.lantronix.com](http://www.lantronix.com) to view the xPico 200 Series User Guide for detailed instructions on the module.



**NOTE:** The use of a web browser on a computer or smartphone is needed to access the wireless module's built-in Web Manager. See [Section 3.4.8 on page 27](#) to view the Wi-Fi and Bluetooth® MAC Addresses from the Tracer AV2 display.

### Soft AP (Access Point) Details

- Name: **RLWS\_XXXXXX**
- Password: **PASSWORD**
- Configuration Page: **http://192.168.0.1**



**NOTE:** The Soft AP only shows up as a 5 GHz network. The connecting device must be capable of using the 5 GHz band to connect to the Soft AP.

## 6.1 Wi-Fi Setup

The following procedure is for setting up the Wi-Fi network using the wireless module's built-in Web Manager.

1. Power on the Tracer AV2.
2. To enable the wireless module and specify Wi-Fi in the Tracer AV2 menu:
  - In setup mode ([Section 4.1 on page 28](#)), navigate to SETUP→COMM→WIFI/BT→ENABLE, and set to WI-FI
  - Press the **ZERO** key multiple times to return to weigh mode
3. Scan for available Wi-Fi networks using a computer or phone and connect to the Soft AP. It might take a few attempts before the Soft AP appears on the computer or phone. The Soft AP only shows up as a 5 GHz network.
  - Soft AP Name: **RLWS\_XXXXXX**
  - Soft AP Password: **PASSWORD**



**IMPORTANT:** It is recommended to change default passwords to limit access and for security.

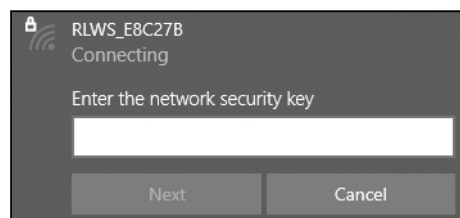

**NOTE:** The X's in the name represent the last 6 digits of the Wi-Fi MAC address. The serial number on the wireless module's label is almost the same, other than the last digit being one number/character less than the Wi-Fi MAC address.

For example, if the module's serial number is "0080A3E8C27A", then the SSID would be "RLWS\_E8C27B". The MAC address is a Hexadecimal value, so the letter A follows the number 9, and this continues to F before incrementing the next most significant digit and returning to 0.

The wireless module's serial number is the same as the Bluetooth® MAC address.

- Once connected to the Soft AP, use a web browser and enter **192.168.0.1** as the URL address and press **Enter**.

 **NOTE:** Once connected to a network, a web browser on that network can connect to the Web Manager by simply navigating to the wireless module's IP Address (available on the Status page of the Web Manager).

- Enter the default login credentials for the Web Manager.

- Username: **admin**
- Password: **PASSWORD**

 **IMPORTANT:** It is recommended to change default passwords to limit access and for security.

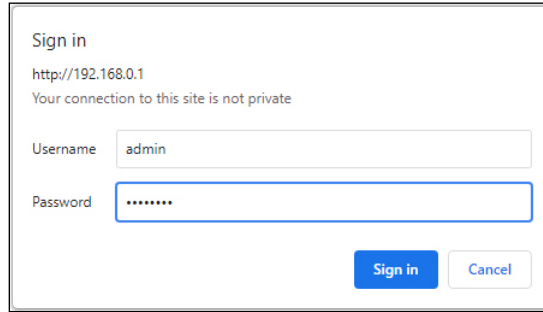

- Press **Sign in**. The Web Manager loads in the browser and the **Status** page appears.
- Click **QuickConnect** at the top of the left nav.

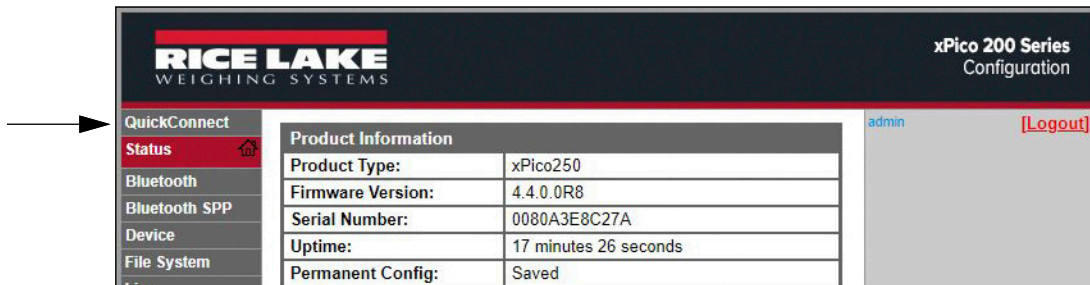

- A list of wireless networks appear. Click the network name intended to connect the wireless module's Wi-Fi network to.

 **NOTE:** If the necessary network does not show up, just click the **Scan** button again. It may take a few tries to show the network. If the network is hidden, enter the network name in the box provided.

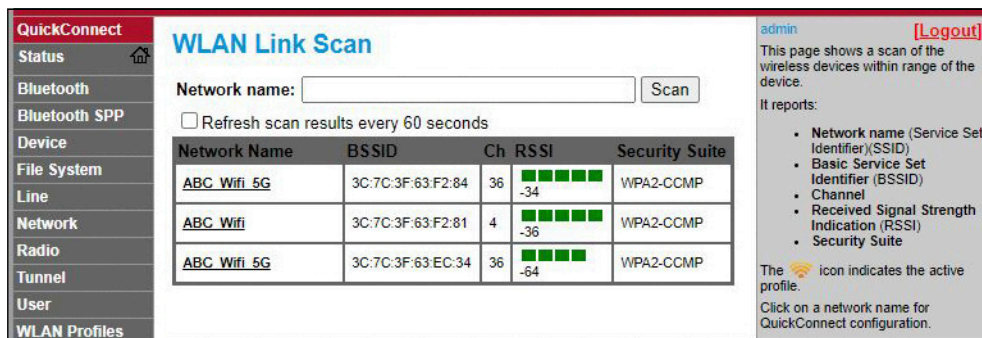

Network Name	BSSID	Ch	RSSI	Security Suite
ABC Wifi 5G	3C:7C:3F:63:F2:84	36	-34	WPA2-CCMP
ABC Wifi	3C:7C:3F:63:F2:81	4	-36	WPA2-CCMP
ABC Wifi 5G	3C:7C:3F:63:EC:34	36	-64	WPA2-CCMP

 **NOTE:** The Web Manager provides notes and information related to the current page in the far right column. Descriptions for options and settings are also provided when hovering over the item in question.

9. The wireless network information page appears. Enter the network password (if applicable).

 **NOTE: Contact location's IT administrator to obtain network credentials as needed based on the security in place.**

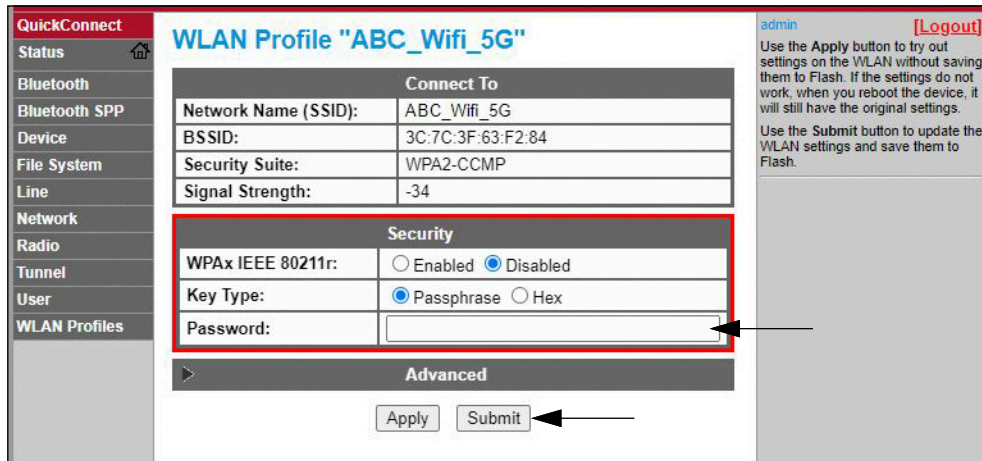

**QuickConnect** | **WLAN Profile "ABC\_Wifi\_5G"** | admin [Logout]

**Status** | **Connect To**

Network Name (SSID):	ABC_Wifi_5G
BSSID:	3C:7C:3F:63:F2:84
Security Suite:	WPA2-CCMP
Signal Strength:	-34

**Security**

WPAx IEEE 80211r:  Enabled  Disabled

Key Type:  Passphrase  Hex

Password:

**Advanced**

Apply Submit

Use the Apply button to try out settings on the WLAN without saving them to Flash. If the settings do not work, when you reboot the device, it will still have the original settings.  
Use the Submit button to update the WLAN settings and save them to Flash.

10. Click **Submit** to apply and save the settings. A message displays at the top of the page to show if the new network's Profile saved successfully. It does not necessarily mean it is connected to the network.

 **NOTE: The Apply button only applies the settings for the current session, but does NOT save them.**

11. To verify that the wireless module is connected to the location's network, click **Status** near the top of the left nav.

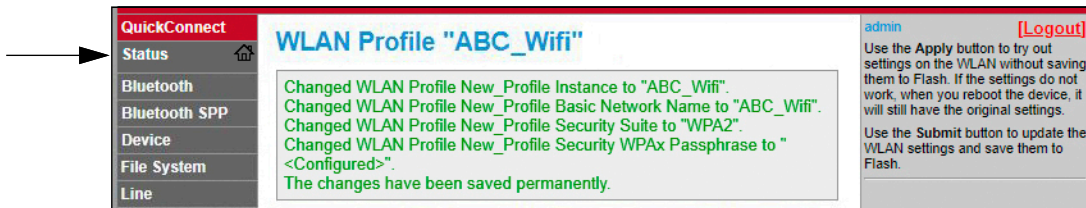

**QuickConnect** | **WLAN Profile "ABC\_Wifi"** | admin [Logout]

**Status** | **Bluetooth** | **Bluetooth SPP** | **Device** | **File System** | **Line**

Changed WLAN Profile New\_Profile Instance to "ABC\_Wifi".  
Changed WLAN Profile New\_Profile Basic Network Name to "ABC\_Wifi".  
Changed WLAN Profile New\_Profile Security Suite to "WPA2".  
Changed WLAN Profile New\_Profile Security WPAx Passphrase to "<Configured>".  
The changes have been saved permanently.

Use the Apply button to try out settings on the WLAN without saving them to Flash. If the settings do not work, when you reboot the device, it will still have the original settings.  
Use the Submit button to update the WLAN settings and save them to Flash.

12. The **Status** page shows all of the network connections on the device under **Network Settings**.

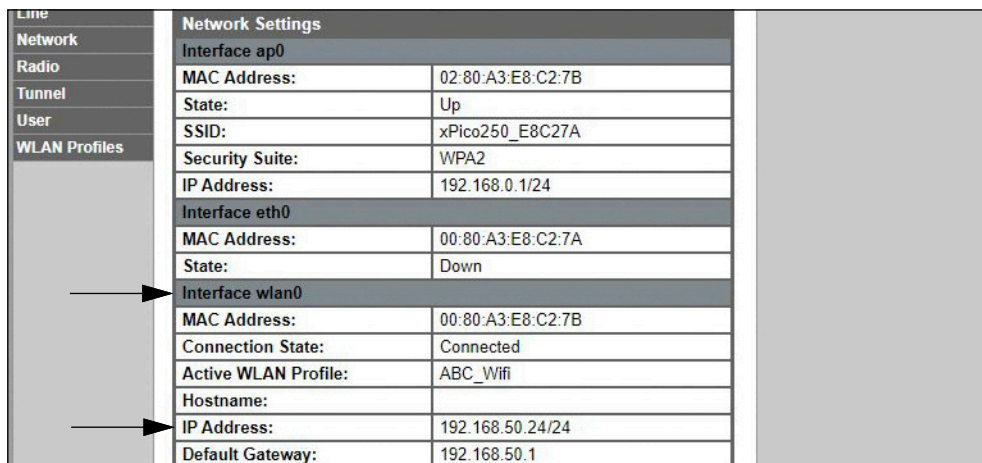

**Line** | **Network** | **Radio** | **Tunnel** | **User** | **WLAN Profiles**

**Network Settings**

**Interface ap0**

MAC Address:	02:80:A3:E8:C2:7B
State:	Up
SSID:	xPico250_E8C27A
Security Suite:	WPA2
IP Address:	192.168.0.1/24

**Interface eth0**

MAC Address:	00:80:A3:E8:C2:7A
State:	Down

**Interface wlan0**

MAC Address:	00:80:A3:E8:C2:7B
Connection State:	Connected
Active WLAN Profile:	ABC_Wifi
Hostname:	
IP Address:	192.168.50.24/24
Default Gateway:	192.168.50.1

- If Connected: **Interface wlan0** is listed with **Connection State** showing **Connected** and the **IP Address** populated.

 **NOTE: The "/24" at the end of the IP Address indicates the number of bits set for the network subnet mask and is not part of the IP Address itself. There are 32 bits in a subnet mask and "/24" indicates the subnet mask is 255.255.255.0.**

- If Not Connected: First try refreshing the browser to see if the information populates, then click **WLAN Profiles** at the bottom of the left nav to change the network settings and try again.

13. Connecting to the wireless module's server with a remote client is now possible.
14. Using a Terminal Emulation program, such as PuTTY, as a remote client connection to the wireless module's server over Telnet is possible using the IP Address that was noted in [Step 12 on page 45](#) and the Local Port number, which by default is 10001.

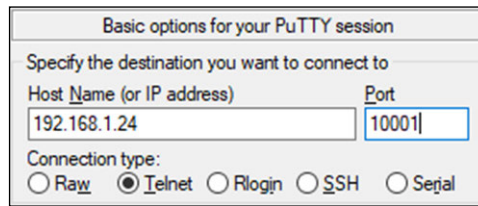

Figure 6-1. PuTTY Example

**NOTE:** If the card's IP address changed and there is no longer access to the card through the location's wireless network, connect to the Soft AP and use the Web Manager to learn the new IP Address.

For more information on all the features of this card, visit [www.lantronix.com](http://www.lantronix.com) to view the xPico 200 Series User Guide.

## 6.2 Server Configuration

The wireless module is configured to be a server by default, with the ability to accept the connection of a client to it.

- A **Server** is waiting to **Accept** a connection from a Client.
- A **Client** is looking to **Connect** to a remote Server (host).

**NOTE:** Even though a device can be set up for both, typically it is only set up as one or the other.

The following procedure shows where the wireless module's server settings are found using the Web Manager.

**NOTE:** Making changes to the Tunnel 1 Accept Configuration settings may impact the wireless module's connection to the location's network, established in [Wi-Fi Setup \(Section 6.1 on page 43\)](#).

1. Refer to [Steps 1-6 in Section 6.1 on page 43](#) to sign in to the Web Manager.
2. Click **Tunnel** in the left nav.



3. Click **Accept** towards the top of the **Tunnel 1 Status** page.

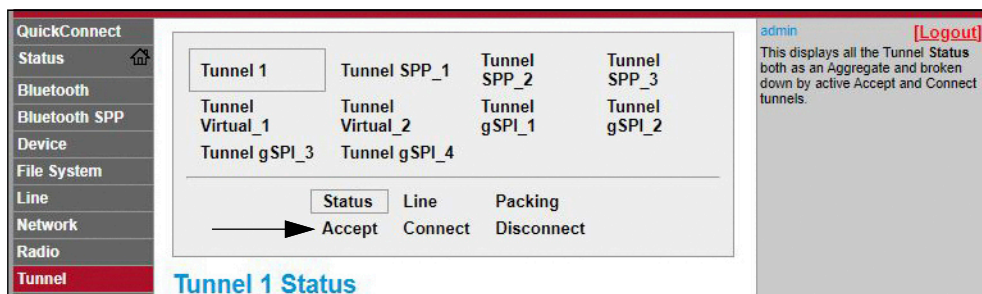

- Change the **Mode** and **Local Port** settings if needed.

Accept Connect Disconnect	
<b>Tunnel 1 Accept Configuration</b>	
Mode:	Always
Local Port:	10001
Multiple Connections:	<input type="radio"/> Enabled <input checked="" type="radio"/> Disabled
Protocol:	TCP
Flush Line:	<input type="radio"/> Enabled <input checked="" type="radio"/> Disabled
Block Line:	<input type="radio"/> Enabled <input checked="" type="radio"/> Disabled
Block Network:	<input type="radio"/> Enabled <input checked="" type="radio"/> Disabled
Password:	

- Click **Submit** at the bottom of the page to apply and save the settings. A message displays at the top of the page to confirm the changes have been saved permanently.

### 6.3 Client Configuration

The wireless module is configured to be a server by default, with the ability to accept the connection of a client to it.

- A **Server** is waiting to **Accept** a connection from a Client.
- A **Client** is looking to **Connect** to a remote Server (host).

The following procedure is for configuring the wireless module as a client, using the Web Manager, to be able to connect the wireless module to an available server connection.

- Refer to [Steps 1-6 in Section 6.1 on page 43](#) to sign in to the Web Manager.
- Click **Tunnel** in the left nav.

- Click **Connect** towards the top of the **Tunnel 1 Status** page.

Tunnel 1	Tunnel SPP_1	Tunnel SPP_2	Tunnel SPP_3
Tunnel Virtual_1	Tunnel Virtual_2	Tunnel gSPI_1	Tunnel gSPI_2
Tunnel gSPI_3	Tunnel gSPI_4		

Status Line Packing  
Accept Connect **Connect**

- Use the drop-down to change the **Mode** setting, and then click **[Edit]** to display available **Host 1** settings.



**NOTE:** The Web Manager provides notes and information related to the current page in the far right column. Descriptions for options and settings are also provided when hovering over the item in question.

<b>Tunnel</b>	Accept <input type="button" value="Connect"/> <input type="button" value="Disconnect"/>	<p>Mode may be "Disable", "Always", "Any Character", "Start Character" or "Modem Control Asserted".</p> <p>A Connect Tunnel can be started in a number of ways, according to its Mode:</p> <p>"Disabled": never started.</p> <p>"Always": always started.</p> <p>"Any Character": started when any character is read on the Serial Line.</p> <p>"Start Character": started when the Start Character is read on the Serial Line.</p>	
User	<b>Tunnel 1 Connect Configuration</b>		
WLAN Profiles	Mode: <input type="text" value="Disable"/>		
	Host 1: <input type="text" value="&lt;None&gt;"/> <input type="button" value="[ Edit ]"/>		
	Connections: <input type="text" value="Sequential"/>		
	Reconnect Time: <input type="text" value="15 seconds"/>		

- Set the **Address** and **Port** as needed to connect to the intended available server connection.

Network	Accept <input type="button" value="Connect"/> <input type="button" value="Disconnect"/>		
Radio	<b>Tunnel 1 Connect Configuration</b>		
<b>Tunnel</b>	Mode: <input type="text" value="Any Character"/>		
User	<b>Host 1</b> <input type="button" value="[ Summary ]"/>		
WLAN Profiles	Address: <input type="text" value="XXX.XXX.XXX.XXX"/>		
	Port: <input type="text" value="XXXX"/>		
	Protocol: <input type="text" value="TCP"/>		
	Initial Send: <input type="text"/>		
	Local Port: <input type="text" value="&lt;Random&gt;"/>		

- Click **Submit** at the bottom of the page to apply and save the settings. A message displays at the top of the page to confirm the changes have been saved permanently.



**NOTE:** While the wireless module's server is still available, it is necessary to adjust the server and client mode settings to allow both to function in unison. Even though a device can be set up for both, typically it is only set up as one or the other. Refer to the xPico 200 Series User Guide at [www.lantronix.com](http://www.lantronix.com) for more information.



## 6.4 Timeout Configuration

The wireless module has an optional Disconnect feature that can be configured to break a connection after a set amount of time. This feature applies to both server and client connections.

The following procedure shows where the wireless module's timeout setting is found using the Web Manager.

1. Refer to [Steps 1-6 in Section 6.1 on page 43](#) to sign in to the Web Manager.
2. Click **Tunnel** in the left nav.

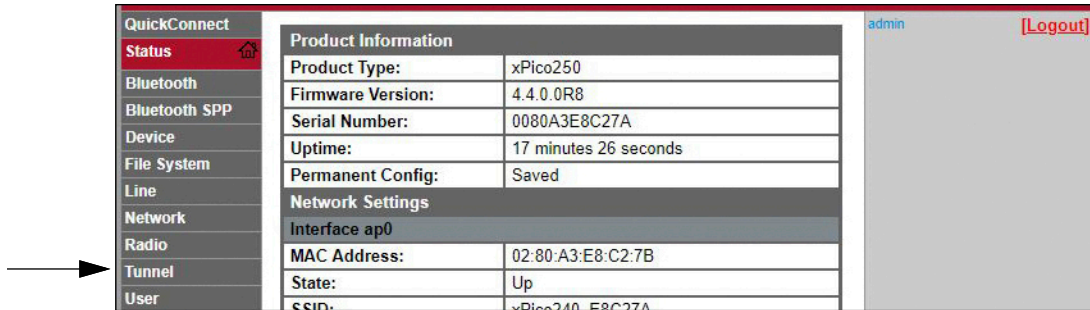

3. Click **Disconnect** towards the top of the **Tunnel 1 Status** page.

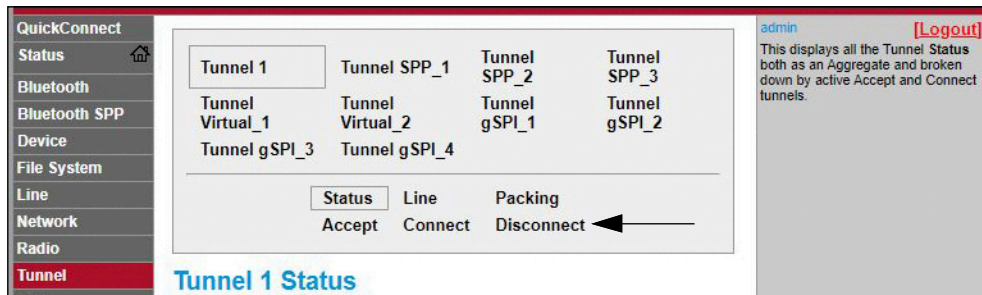

4. Enter the desired value in milliseconds for the **Timeout** setting. A value entry of 0 disables the Disconnect feature.

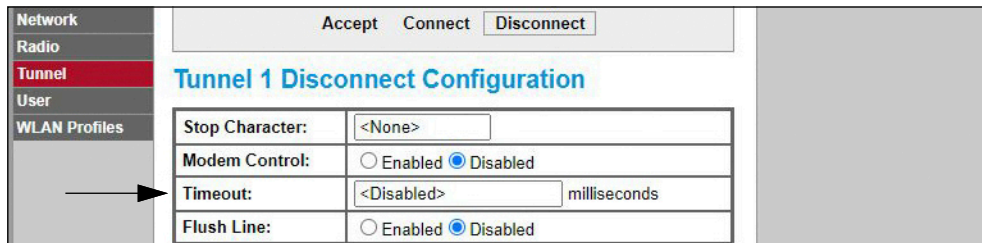

5. Click **Submit** at the bottom of the page to apply and save the settings. A message displays at the top of the page to confirm the changes have been saved permanently.

## 6.5 Wireless Module Wi-Fi Specifications

The Tracer AV2 features a Lantronix® xPico 200 Series wireless module. Visit [www.lantronix.com](http://www.lantronix.com) to view the latest list of technical specifications on the wireless module.

### Wireless Specifications

- IEEE 802.11 a/b/g up to 54 Mbps; 802.11 n (1×1) up to 150 Mbps
- 20 and 40 MHz channel width with optional SGI
- Dual Band 2.4 GHz and 5 GHz, Channels 1-13, UNII-1, 2a, 2e and 3
- Supports IEEE 802.11 d/h/i
- Bluetooth®/WLAN Coexistence
- 802.11r fast roaming

### Data Communication

- TruPort® Serial Technology – TCP and UDP Server Mode, TCP and UDP Client Mode, Multi-host Connect; TLS Client and Server
- TruPort® Socket – Multi-host Client and Server Modes, HTTP(S), Sockets, TLS
- Authenticated SMTP Support – Send email directly from device

### Security and Authentication

- TruPort® Security Software
  - Secure Boot, Secure Firmware-Over-the-Air (FOTA) Updates
  - Secure Key Storage, Encrypted Configuration
  - Secure Connections with SSL/TLS, HTTPS
  - Software Controlled Network Service Ports Enable/Disable
  - Role Based Access Control
- AES/CCMP and TKIP encryption, WPA/WPA2 Personal
- WPA2 Enterprise (EAP-TLS, EAP-TTLS, EAP-PEAP, EAP-FAST)
- SSLv3/TLS 1.2 with PKI and X.509 Certificates (up to 4096-bit Keys)
- AES Algorithm, 256-bit, 192-bit, 128-bit

### Management Interfaces

- Lantronix ConsoleFlow™ Cloud Software Platform, REST, MQTT
- Lantronix Discovery Protocol (77FE)
- Serial Port, Internal Web Server (HTTP/HTTPS)
- XML Configuration and XML Status (CLI, API)
- Secure Firmware Upgrade via HTTPS, ConsoleFlow™

### Protocol Support

- DHCP Client, Server (Soft AP), HTTP Server/Client
- IPv4, TCP/IP, UDP/IP, ARP, ICMP, Auto-IP, DNS
- SNMP v1/v2
- IPv6

### Wireless Features

- Concurrent Soft AP + STA (Client), Client, Soft AP
- Up to 5 simultaneous client connections to Soft AP interface
- Up to 4 in Concurrent Mode
- Connect to multiple WLAN networks, WLAN QuickConnect

### Certifications & Compliance

- Type Approvals: USA (FCC Part 15), Canada (IC RSS), EU (RED), Japan (MIC), China (SRRC), AU/NZS
- Safety: IEC 62368 EN 62368, EN 62311, UL 60950
- RoHS, REACH
- FCC ID: R68XPICO200
- CMIIT ID: 2017AJ6663(M)

## 7.0 Bluetooth® Configuration

The Tracer AV2 is a Wi-Fi or Bluetooth® device. Configuration of the wireless settings is done through the built-in Web Manager. The Web Manager can be accessed through the built-in Soft AP (Access Point) and by default, the Soft AP is available any time the unit is powered up.

The Soft AP connection can also be used to talk to a Tracer AV2 by connecting to IP 192.168.0.1, port 10001.

The Tracer AV2 wireless module, by default, has the connected antenna set for Wi-Fi communications. The radio antenna setting must be changed to Bluetooth® in order to use the Bluetooth® communications feature of the wireless module.



**NOTE:** *Even with the antenna set to Bluetooth®, it is still possible to scan for available Wi-Fi networks using a computer or phone and connect to the Soft AP to access the wireless module's Web Manager.*

The Tracer AV2 features a Lantronix® xPico 200 Series wireless module. Visit [www.lantronix.com](http://www.lantronix.com) to view the xPico 200 Series User Guide for detailed instructions on the module.



**NOTE:** *The use of a web browser on a computer or phone is needed to access the wireless module's built-in Web Manager. See Section 3.4.8 on page 27 to view the Wi-Fi and Bluetooth® MAC Addresses from the Tracer AV2 display.*

### 7.1 Bluetooth® Setup

The following procedure is for setting the antenna to Bluetooth® communications using the wireless module's built-in Web Manager and then pairing to a Bluetooth® device.

1. Power on the Tracer AV2.
2. To enable the wireless module and specify Bluetooth® in the Tracer AV2 menu:
  - In setup mode (Section 4.1 on page 28), navigate to SETUP→COMM→WIFI/BT→ENABLE, and set to BTOOTH
  - Press the **ZERO** key multiple times to return to weigh mode
3. Scan for available Wi-Fi networks using a computer or phone and connect to the Soft AP. It might take a few attempts before the Soft AP appears on the computer or phone. The Soft AP only shows up as a 5 GHz network.
  - Soft AP Name: **RLWS\_XXXXXX**
  - Soft AP Password: **PASSWORD**



**IMPORTANT:** *It is recommended to change default passwords to limit access and for security.*

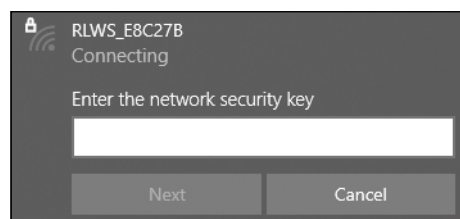

**NOTE:** *The X's in the name represent the last 6 digits of the Wi-Fi MAC address. The serial number on the wireless module's label is almost the same, other than the last digit being one number/character less than the Wi-Fi MAC address.*

*For example, if the wireless module's SSID is "RLWS\_E8C27B", then the Bluetooth® MAC address would be "0080A3E8C27A". The MAC address is a Hexadecimal value, so the letter A follows the number 9, and this continues to F before incrementing the next most significant digit and returning to 0.*

*The wireless module's serial number is the same as the Bluetooth® MAC address.*

4. Once connected to the Soft AP, use a web browser and enter **192.168.0.1** as the URL address and press **Enter**.
5. Enter the default login credentials for the Web Manager.
  - Username: **admin**
  - Password: **PASSWORD**

 **IMPORTANT:** It is recommended to change default passwords to limit access and for security.

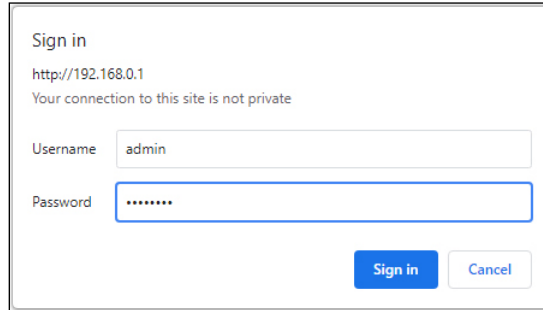

6. Press **Sign in**. The Web Manager loads in the browser and the **Status** page appears.
7. Click **Radio** in the left nav.

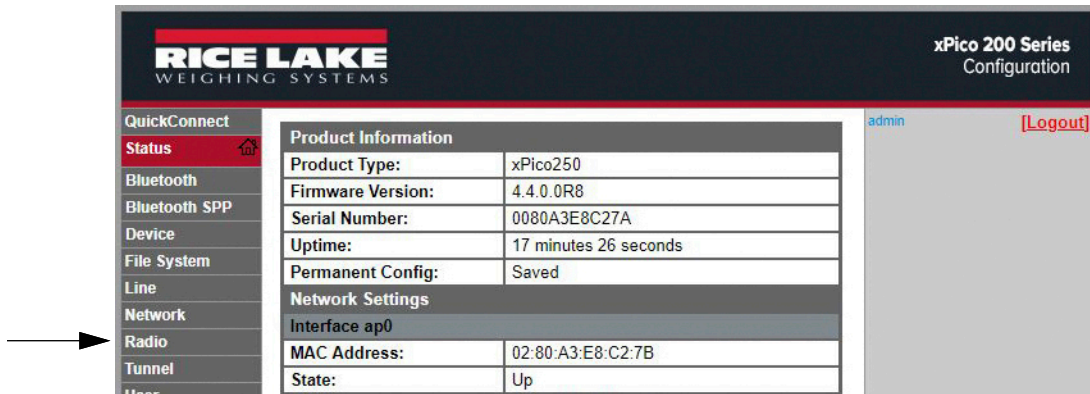

8. Click **Configuration** at the top of the **Radio Status** page.

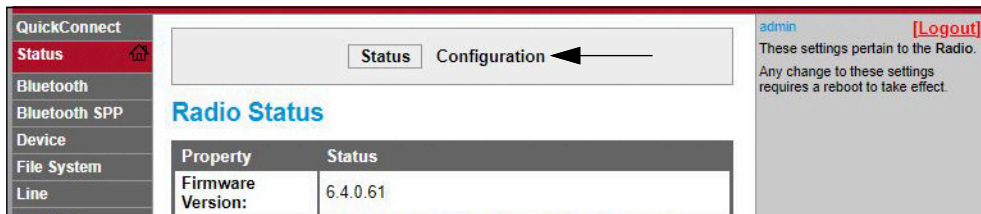

9. Change the **Antenna 1 Supports** drop-down option to **Bluetooth®**.

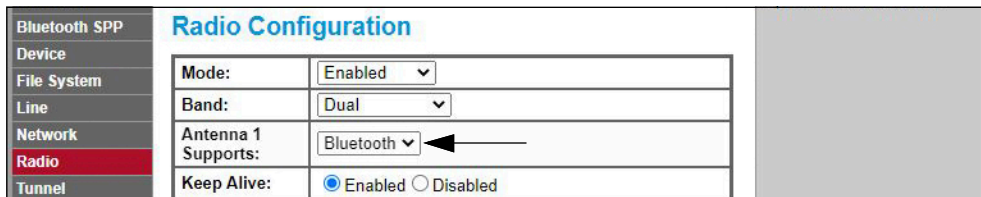

- Click **Submit** to apply and save the settings. A message displays at the top of the page to warn that the new radio settings won't take effect until after the next reboot.

Bluetooth SPP	<b>Radio Configuration</b>	
Device	<p>Changed Radio Antenna 1 Supports to "Bluetooth". The changes have been saved permanently.</p> <p><b>WARNING: Change in Radio settings will take effect on the next reboot.</b></p>	
File System		
Line		
Network		
<b>Radio</b>	Mode:	Enabled ▾
Tunnel	Band:	Dual ▾
User	Antenna 1 Supports:	Bluetooth ▾
WLAN Profiles		

- Cycle power to the Tracer AV2.
- Scan for available Bluetooth® devices on the device that is intended to be paired with the Tracer AV2. The Tracer AV2 wireless module's Bluetooth® device name is **RLWS\_XXXXXXXXXXXX**.



**NOTE:** The X's in the name represent the entire Bluetooth® MAC address.

- Pair the intended Bluetooth® device with the Tracer AV2 wireless module's Bluetooth® connection.

## 7.2 Wireless Module Bluetooth® Specifications

The Tracer AV2 features a Lantronix® xPico 200 Series wireless module. Visit [www.lantronix.com](http://www.lantronix.com) to view the latest list of technical specifications on the wireless module.

- Compliant to Bluetooth® Core Specification version 4.2 (BR/EDR/Bluetooth® LE)
- Bluetooth® LE Central and Peripheral Roles
- Support for Generic Access Profile (GAP), Generic Attribute Profile (GATT), Device ID Profile
- Serial Port Profile (SPP)



**NOTE:** See [Section 6.5 on page 50](#) for the general wireless module specifications.

## 8.0 Revolution

The Revolution utility provides a suite of functions used to support the customization, calibration and backup of the Tracer AV2 configuration.

Calibration values and scale configuration can both be saved and restored to the Tracer AV2 using Revolution.



**NOTE:** For system requirements visit the Revolution product page on [Rice Lake Weighing Systems website](#).

### 8.1 Connecting to the Indicator

Connect the PC serial port to COM 1 of the Tracer AV2, then click **Connect** in the toolbar. Revolution attempts to establish communications to the indicator. If communications settings need to be adjusted, select **Options...** from the Tools menu.

#### Downloading to the Indicator

The **Send Configuration to Device** function in the Revolution Communications menu allows a Revolution configuration file (with or without scale calibration data) or ticket formats to be sent/downloaded to a connected indicator in setup mode.

The **Send Section to Device** function in the Communications menu allows the download of only the currently displayed object, such as a scale configuration.

Because less data is transferred using the **Send Section to Device**, it is typically faster than a full configuration download, but there is an increased possibility the download fails due to dependencies on other objects. If the download fails, try performing a complete download using the **Send Configuration to Device** function.

#### Uploading Configuration to Revolution

The **Get Configuration from Device** function in the Revolution Communications menu allows the existing configuration of a connected indicator to be saved to a file on the PC. Once saved, the configuration file provides a backup which can be quickly restored to the indicator if needed. Alternatively, the file can be edited within Revolution and sent back to the indicator.

### 8.2 Saving and Transferring Data



**NOTE:** Revolution has a module to save and transfer data. It is the preferred method over using ProComm or Hyper Terminal.

#### 8.2.1 Saving Indicator Data to a PC

Configuration data can be saved to a PC connected to the selected port. The PC must be running a communications program such as PROCOMMPLUS®.

When configuring the indicator, ensure the values set for the baud and bits parameters on the serial menu match the baud rate, bits and parity settings configured for the serial port on the PC.

To save all configuration data, first put the communications program into data capture mode, then place the indicator in setup mode and send the DUMPALL command to the indicator. The Tracer AV2 responds by sending all configuration parameters to the PC as ASCII-formatted text.

#### 8.2.2 Downloading Configuration Data from PC to Indicator

Configuration data saved on a PC or disc can be downloaded from the PC to an indicator. This procedure is useful when a number of units with similar configurations are set up or when a unit is replaced.

To download configuration data, connect the PC to the selected port as described in [Section 8.2.1](#). Place the Tracer AV2 in setup mode and use the PC communications software to send the saved configuration data to the indicator. When transfer is complete, calibrate the Tracer AV2 as described in [Section 5.0 on page 40](#).

### 8.3 Updating Firmware

Revolution is used to update the firmware of the Tracer AV2. The link to begin this process is available on the Revolution home screen. Updating the firmware defaults configuration settings.

## 9.0 EDP Commands

The Tracer AV2 can be controlled by a computer connected to one of the communication ports. Control is provided by a set of commands which can simulate keypad key press functions, return and change setup parameters, and perform reporting functions. The commands provide the capability to print configuration data or to save data to an attached personal computer. This section describes the EDP command set and procedures for saving and transferring data using the communication ports.

When the Tracer AV2 processes a command, it either responds with a value (for reporting commands, or when querying parameter settings), or with the message **OK**. The **OK** response verifies the command was received and has been executed. If the command is unrecognized, the Tracer AV2 responds with **?? invalid command**. If the command cannot be executed in the current mode, the Tracer AV2 responds with **?? invalid mode**. If the command is recognized, but the type is invalid or the value is out of range, the Tracer AV2 responds with **??** followed by the type and the range.

### 9.1 Key Press Commands

Key press serial commands simulate the pressing of keys. These commands can be used in setup and weigh mode. Several of the commands serve as pseudo keys, providing functions which are not represented by a key on the optional keypad.

For example, to zero the scale and switch units using serial commands:

1. Type **KZERO** and press **Enter** (or **Return**).
2. Type **KUNITS** and press **Enter**.

Command	Function
KZERO	In weigh mode, this command acts like pressing the <b>ZERO</b> key
KGROSS	Displays Gross mode (pseudo key)
KUNITS	In weigh mode, this command acts like pressing the <b>UNITS</b> key
KPRIM	Displays primary units (pseudo key)
KSEC	Displays secondary units (pseudo key)
KPRINT	In weigh mode, this command acts like pressing the <b>PRINT</b> key
KACCUM	In weigh mode, this command acts like pressing the <b>ACCUM</b> Key and performs the accumulator print function
KCLRCN	Clears consecutive number (pseudo key)
KLEFT	In setup mode, this command moves <b>Left</b> in the menu
KRIGHT	In setup mode, this command moves <b>Right</b> in the menu
KUP	In setup mode, this command moves <b>Up</b> in the menu
KDOWN	In setup mode, this command moves <b>Down</b> in the menu
KEXIT	In setup mode, this command exits to weigh mode (pseudo key)
KSAVE	In setup mode, this command saves the current configuration (pseudo key)
KSAVEEXIT	In setup mode, this command saves the current configuration and exits to weigh mode (pseudo key)
KENTER	This command acts like pressing the <b>ENTER</b> key
KMENU	This command acts like pressing the <b>ENTER</b> key
KYBDLK	In setup mode, this command locks the keys, except for the <b>ENTER</b> key
KLOCK=x	In setup mode, this command locks specified front panel key; x = KPRINT, KUNITS, KZERO, KACCUM, KENTER (example: to lock the <b>ZERO</b> key, enter KLOCK=KZERO)
KUNLOCK=x	In setup mode, this command unlocks specified front panel key; x = KPRINT, KUNITS, KZERO, KACCUM, KENTER (example: to unlock the <b>PRINT</b> key, enter KUNLOCK=KPRINT)

Table 9-1. Key Press Commands

## 9.2 Reporting Commands

Reporting commands send specific information to the communications port. The commands listed in [Table 9-2](#) can be used in either setup mode or weigh mode.

Command	Function
DUMPALL	Returns a list of all parameter values
DUMPAUDIT	Returns the Audit Trail information
KDUMPAUDIT	Returns the Audit Trail information on the same port which the EDP command was sent
AUDIT.LRVERSION	Returns the legally relevant firmware version
AUDIT.CONFIG	Returns the number of times configuration has changed
AUDIT.CALIBRATE	Returns the number of calibrations
AUD.PORT	Sets audit destination port 1; <i>Settings: RS232-1 (default), RS232-2, TCPC, TCPS, WIFIBT, USB, NONE</i>
AUD.PORT2	Sets audit destination port 2; <i>Settings: NONE (default), RS232-1, RS232-2, TCPC, TCPS, WIFIBT, USB</i>
AUDITJUMPER	Returns the position of the audit jumper (ON or OFF)
VERSION	Returns the firmware version
BUILD	Returns the firmware version with a build number
HWSUPPORT	Returns the CPU board part number

Table 9-2. Reporting Commands

## 9.3 Reset Configuration Command

The following command can be used to reset the configuration parameters of the Tracer AV2.

Command	Function
RESETCONFIGURATION	Restores all configuration parameters to default values (setup mode only)

Table 9-3. Reset Configuration Command



**NOTE:** All scale calibration settings are lost when the **RESETCONFIGURATION** command is run.



## 9.4 Parameter Setting Commands

Parameter setting commands allow the current value for a configuration parameter to be displayed or changed. Current configuration parameter settings can be displayed in setup mode or weigh mode using the following syntax:  
command<ENTER>

Most parameter values can be changed in setup mode only.

Use the following command syntax when changing parameter values: command=value<ENTER>, where **value** is either a number or a parameter value. Use no spaces before or after the equal (=) sign. If an incorrect command is typed or an invalid value is specified, the indicator returns ?? followed by the error message.

*Example: to set the motion band parameter on Scale #1 to 5 divisions, type the following:*

**SC.MOTBAND#1=5<ENTER>**

To return a list of the available values for parameters with specific values, enter the command and equal sign, followed by a question mark (command=?<ENTER>). The indicator must be in setup mode to use this function.

After changes are made to configuration parameters using EDP commands, use the **KSAVE** or **KSAVEEXIT** commands to commit the changes to memory.



**NOTE:** The operator must stop the current batch for new values to take effect.

Command	Description	Values
SC.CAPACITY#n	Scale capacity	0.0000001–9999999.0, <b>500.0</b> (default)
SC.CAPACITYLABEL#n	Returns the following scale information separated by a   character:  primary capacity   primary division size   primary units   secondary capacity   secondary division size   secondary units	—
SC.ZTRKBND#n	Zero track band (in display divisions)	0.0–100.0, <b>0.0</b> (default)
SC.ZRANGE#n	Zero range (%)	0.0–100.0, <b>1.9</b> (default)
SC.MOTBAND#n	Motion band (in display divisions)	0–100, <b>1</b> (default)
SC.SSTIME#n	Standstill time (in 0.1 second intervals; 10 = 1 second)	0–600, <b>10</b> (default)
SC.OVERLOAD#n	Overload	<b>FS+2%</b> (default), FS+1D, FS+9D, FS
SC.WMTTHR#n	Weighment threshold	0.0–9999999.0, <b>1000.0</b> (default)
SC.NUMWEIGH#n	Number of weighments	0–4294967295 (uint_32_t_max), <b>0</b> (default)
SC.DIGFLTR1#n SC.DIGFLTR2#n SC.DIGFLTR3#n	Number of A/D samples averaged for the individual stages (1-3) of the three stage digital filter	1, 2, 4, 8, 16, <b>32</b> (default), 64, 128, 256
SC.DFSENS#n	Digital filter cutout sensitivity	<b>2OUT</b> (default), 4OUT, 8OUT, 16OUT, 32OUT, 64OUT, 128OUT
SC.DFTHR#n	Digital filter cutout threshold	NONE, 2D, <b>5D</b> (default), 10D, 20D, 50D, 100D, 200D, 250D
SC.RATLTRAP#n	Rattletrap filtering	<b>OFF</b> (default), ON
SC.SMPRAT#n	Scale A/D sample rate	6.25HZ, 7.5HZ, 12.5HZ, 15HZ, 25HZ, <b>30HZ</b> (default), 50HZ, 60HZ, 100HZ, 120HZ
SC.PWRUPMD#n	Power up mode	<b>GO</b> (default), DELAY
SC.PRI.FMT#n	Primary units format (decimal point and display divisions)	8888100, 8888200, 8888500, 8888810, 8888820, 8888850, <b>8888881</b> (default), 8888882, 8888885, 888888.1, 888888.2, 888888.5, 88888.81, 88888.82, 88888.85, 8888.881, 8888.882, 8888.885, 888.8881, 888.8882, 888.8885, 88.88881, 88.88882, 88.88885
SC.PRI.UNITS#n	Primary units	<b>LB</b> (default), KG
SC.SEC.FMT#n	Secondary units format (decimal point and display divisions)	8888100, 8888200, 8888500, 8888810, 8888820, 8888850, 8888881, 8888882, 8888885, 888888.1, 888888.2, <b>888888.5</b> (default), 88888.81, 88888.82, 88888.85, 8888.881, 8888.882, 8888.885, 888.8881, 888.8882, 888.8885, 88.88881, 88.88882, 88.88885

For commands ending with #n, n is the scale number (1)

Table 9-4. Scales Commands

Command	Description	Values
SC.SEC.UNITS# <i>n</i>	Secondary units	LB, <b>KG</b> (default)
SC.SEC.ENABLED# <i>n</i>	Enable the secondary units	<b>ON</b> (default), OFF
SC.FILTERCHAIN# <i>n</i>	Defines what filter to use	<b>AVGONLY</b> (default), ADPONLY, DMPONLY, RAW
SC.DAMPINGVALUE# <i>n</i>	Sets the damping time constant	0–2560 (in 0.1 second intervals), <b>10</b> (default)
SC.ADTHRESHOLD# <i>n</i>	Adaptive filter weight threshold value	0–2000 (in display divisions), <b>10</b> (default)
SC.ADSENSITIVITY# <i>n</i>	Adaptive filter sensitivity	<b>LIGHT</b> (default), MEDIUM, HEAVY
SC.WZERO# <i>n</i>	Perform zero calibration	—
SC.TEMPZERO# <i>n</i>	Perform temporary zero calibration	—
SC.LASTZERO# <i>n</i>	Perform last zero calibration	—
SC.REZERO# <i>n</i>	Perform the Rezero calibration function	—
SC.WVAL# <i>n</i>	Test weight value	0.000001–9999999.999999, <b>500.0</b> (default)
SC.WSPAN# <i>n</i>	Perform span calibration	—
SC.WLIN.F1# <i>n</i> – SC.WLIN.F4# <i>n</i>	Actual raw count value for linearization points 1–4	0–16777215, <b>0</b> (default)
SC.WLIN.V1# <i>n</i> – SC.WLIN.V4# <i>n</i>	Test weight value for linearization points 1–4 (A setting of 0 indicates the linearization point is not used)	0.000001–9999999.999999, <b>0.0</b> (default)
SC.WLIN.C1# <i>n</i> – SC.WLIN.C4# <i>n</i>	Perform linearization calibration on points 1–4	—
SC.LC.CD# <i>n</i>	Deadload coefficient raw count value	0–16777215, <b>8386509</b> (default)
SC.LC.CW# <i>n</i>	Span coefficient raw count value	0–16777215, <b>2186044</b> (default)
SC.LC.CZ# <i>n</i>	Temporary zero raw count value	0–16777215, <b>2186044</b> (default)
SC.INITIALZERO# <i>n</i>	Initial Zero range in % of full scale	0.0–100.0, <b>0.0</b> (default)
SC.SENSE# <i>n</i>	Specifies the type of load cell cable connected	<b>4-WIRE</b> (default), 6-WIRE

For commands ending with #*n*, *n* is the scale number (1)

Table 9-4. Scales Commands (Continued)

## 9.5 Serial Port Commands

Command	Description	Values
EDP.TRIGGER# <i>p</i>	Port serial input trigger type	<b>CMD</b> (default), STRIND, STRLFT
EDP.BAUD# <i>p</i>	Port baud rate	1200, 2400, 4800, <b>9600</b> (default), 19200, 28800, 38400, 57600, 115200
EDP.BITS# <i>p</i>	Port data bits/parity	<b>8NONE</b> (default), 7EVEN, 7ODD
EDP.TERMIN# <i>p</i>	Port line termination character	<b>CR/LF</b> (default), CR
EDP.STOPBITS# <i>p</i>	Port stop bits	<b>1</b> (default), 2
EDP.ECHO# <i>p</i>	Port echo	<b>ON</b> (default), OFF
EDP.RESPONSE# <i>p</i>	Port response	<b>ON</b> (default), OFF
EDP.EOLDLY# <i>p</i>	Port end-of-line delay	0–255 (0.1 second intervals), <b>0</b> (default)

For commands ending with #*p*, *p* is the port number (1-2)

Table 9-5. Serial Port Commands

## 9.6 USB Commands

Command	Description	Values
USB.TRIGGER	USB input trigger type	<b>CMD</b> (default), STRIND, STRLFT
USB.LINETERM	USB line terminator	<b>CR/LF</b> (default), CR
USB.ECHO	USB echo	<b>ON</b> (default), OFF
USB.RESPONSE	USB response	<b>ON</b> (default), OFF
USB.EOLDLY	USB end of line delay	0–255 (0.1 second intervals), <b>0</b> (default)

Table 9-6. Communications Commands

## 9.7 TCP Server and Client Commands

Command	Description	Values
TCPC1.ECHO	TCP Client 1 echo	<b>ON</b> (default), OFF
TCPC1.EOLDLY	TCP Client 1 end-of-line delay	0–255 (0.1 second intervals), <b>0</b> (default)
TCPC1.IPADDR	TCP Client 1 remote server IP	Valid IP xxx.xxx.xxx.xxx*, <b>0.0.0.0</b> (default)
TCPC1.LINETERM	TCP Client 1 line termination	<b>CR/LF</b> (default), CR
TCPC1.PORT	TCP Client 1 remote server port	1025–65535, <b>10001</b> (default)
TCPC1.RESPONSE	TCP Client 1 response	<b>ON</b> (default), OFF
TCPC1.TRIGGER	TCP Client 1 input trigger type	<b>CMD</b> (default), STRIND, STRLFT
TCPC1.DISCTIME	TCP Client 1 disconnect time (in seconds)	0–60 (0= do not disconnect), <b>0</b> (default)
TCPS.PORT	TCP Server port number	1025–65535, <b>10001</b> (default)
TCPS.HOSTNAME	TCP Server host name	Up to 30 alphanumeric characters, <b>0</b> (default)
TCPS.TRIGGER	TCP Server input trigger type	<b>CMD</b> (default), STRIND, STRLFT
TCPS.ECHO	TCP Server echo	<b>ON</b> (default), OFF
TCPS.LINETERM	TCP Server line termination	<b>CR/LF</b> (default), CR
TCPS.RESPONSE	TCP Server response	<b>ON</b> (default), OFF

\*A valid IP consists of four numbers, in the range of 0 to 255, separated by a decimal point (127.0.0.1 and 192.165.0.230 are valid IP addresses)

Table 9-7. Communications Commands

## 9.8 Wi-Fi and Bluetooth® Commands

Command	Description	Values
WIFIBT.ENABLED	Enables the wireless module and specifies Wi-Fi or Bluetooth®	<b>OFF</b> (default), WIFI, BLUETOOTH
WIFIBT.TRIGGER	Wi-Fi/Bluetooth® input trigger type	<b>CMD</b> (default), STRIND, STRLFT
WIFIBT.TERMIN	Wi-Fi/Bluetooth® line terminator	<b>CR/LF</b> (default), CR
WIFIBT.ECHO	Wi-Fi/Bluetooth® echo	<b>ON</b> (default), OFF
WIFIBT.RESPONSE	Wi-Fi/Bluetooth® response	<b>ON</b> (default), OFF
WIFIBT.EOLDLY	Wi-Fi/Bluetooth® end of line delay	0–255 (0.1 second intervals), <b>0</b> (default)
BLUETOOTH.MACID	Bluetooth® MAC address (read only)	xx:xx:xx:xx:xx:xx
WIFI.MACID	Wi-Fi MAC address (read only)	xx:xx:xx:xx:xx:xx

Table 9-8. Communications Commands

## 9.9 Wired Ethernet Commands

Command	Description	Values
WIRED.MACID	Ethernet hardware MAC ID (read only)	xx:xx:xx:xx:xx:xx
WIRED.DHCP	Enable Ethernet DHCP	<b>ON</b> (default), OFF
WIRED.ENABLED	Enable wired Ethernet adapter	ON, <b>OFF</b> (default)
WIRED.IPADDR	Ethernet IP address	Valid IP xxx.xxx.xxx.xxx*, <b>0.0.0.0</b> (default)
WIRED.SUBNET	Ethernet subnet mask	Valid IP xxx.xxx.xxx.xxx*, <b>255.255.255.0</b> (default)
WIRED.GATEWAY	Ethernet gateway	Valid IP xxx.xxx.xxx.xxx*, <b>0.0.0.0</b> (default)

\*A valid IP consists of four numbers, in the range of 0 to 255, separated by a decimal point (127.0.0.1 and 192.165.0.230 are valid IP addresses)

Table 9-9. Communications Commands

## 9.10 Stream Setting Commands

Command	Description	Values
STRM.FORMAT#n	Stream format	<b>RLWS</b> (default), CARDNAL, WTRONIX, TOLEDO
STRM.UNITS#n	Stream updates with unit configuration	<b>STATIC</b> (default), DYNAMIC
For commands ending with #n, n is the stream format number (1)		

Table 9-10. Stream Formatting Commands

## 9.11 Feature Commands

Command	Description	Values
CONSNUM	Consecutive numbering	0–9999999, <b>0</b> (default)
CONSTUP	Consecutive number start-up value	0–9999999, <b>0</b> (default)
UID	ID of the indicator	Up to 8 alphanumeric characters, <b>1</b> (default)
KYBDLK	Keyboard lock (disable keypad)	<b>OFF</b> (default), ON
ZERONLY	Disable all keys except ZERO	<b>OFF</b> (default), ON
MENUACCESSDELAY	Enter key hold time (in seconds) to access user menu	0-30, <b>10</b> (default)
KHOLDTIME	Key hold time (in tenths of a second); 20 equals 2 seconds	10–50, <b>20</b> (default)
KHOLDINTERVAL	Key hold time interval; the amount of time between increments during a key hold (in twentieths of a second); 2 equals a tenth of a second (10 increments per second during a key hold)	1–100, <b>2</b> (default)
LOCALE	Enable gravity compensation	<b>OFF</b> (default), ON, FACTOR
LAT.LOC	Origin latitude (to nearest degree) for gravity compensation	0–90, <b>45</b> (default)
ELEV.LOC	Origin elevation (in meters) for gravity compensation	-9999–9999, <b>345</b> (default)
DEST.LAT.LOC	Destination latitude (in degrees) for gravity compensation	0–90, <b>45</b> (default)
DEST.ELEV.LOC	Destination elevation (in meters) for gravity compensation	-9999–9999, <b>345</b> (default)
GRAV.LOC	Origin gravity factor (in m/s <sup>2</sup> ) for gravity compensation	9.00000–9.99999, <b>9.80665</b> (default)
DEST.GRAV.LOC	Destination gravity factor (in m/s <sup>2</sup> ) for gravity compensation	9.00000–9.99999, <b>9.80665</b> (default)
ALARM.ENABLE	Enables alarm	ON, <b>OFF</b> (default)
ALARM.VALUE	Sets the weight value at which alarm is tripped	0.000001–9999999, <b>50</b> (default)
ALARM.MESSAGE	Sets the alarm message displayed when alarm is tripped	Up to 20 alphanumeric characters, <b>OVERWEIGHT</b> (default)

Table 9-11. Feature Commands

## 9.12 Print Format Commands

Command	Description	Values
GFMT.MODE	Gross format print modes	<b>STANDARD</b> (default), AUTO, MULTI
GFMT.PORT	Primary gross format print port	<b>RS232-1</b> (default), RS232-2, TCPC, TCPS, WIFIBT, USB, NONE
GFMT.PORT2	Secondary gross format print port	<b>NONE</b> (default), RS232-1, RS232-2, TCPC, TCPS, WIFIBT, USB
GFMT.RTZ	Print format return to zero graduation value; available for AUTO and MULTI; hidden for STANDARD	0-9999999, <b>0</b> (default)
GFMT.THRH	Print format threshold graduation value; available for AUTO and MULTI; hidden for STANDARD	0-9999999, <b>10</b> (default)
See <a href="#">Section 4.4.6 on page 36</a> for information about print format modes		

Table 9-12. Print Format Commands

## 9.13 Regulatory Commands

Command	Description	Values
REGULAT	Regulatory mode	<b>NTEP</b> (default), CANADA, INDUST, NONE, OIML
AUDAGNCY	Audit Agency (Industrial Mode)	<b>NTEP</b> (default), CANADA, NONE, OIML
REG.NEGTOTAL	Allow total scale to display negative value	<b>NO</b> (default), YES
REG.PRTMOT	Allow print while in motion	<b>NO</b> (default), YES
REG.PRTHLD	Print during display hold	<b>NO</b> (default), YES
REG.HLDWGH	Allow weighment during display hold	<b>NO</b> (default), YES
REG.MOTWGH	Allow weighment in motion	<b>NO</b> (default), YES
REG.OVRBASE	Zero base for overload calculation	<b>CALIB</b> (default), SCALE
REGWORD	Regulatory word	<b>GROSS</b> (default), BRUTTO
REG.ZEROINMOTION	Allows scale to be zeroed while in motion	<b>NO</b> (default), YES
REG.UNDERLOAD	Underload weight value in display divisions	1–9999999, <b>20</b> (default)

NTEP defaults shown for regulatory command values

Table 9-13. Regulatory Commands

## 9.14 Digital I/O Commands

Command	Description	Values
DIO. <i>b</i> # <i>s</i>	Sets DIO type	<b>OFF</b> (default), PRINT, ACCUM, ZERO, UNITS, PRIM, SEC, CLEAR, CLRRCN, KBDLOC, OUTPUT
DOFF. <i>b</i> # <i>s</i>	Sets digital output to OFF	–
DON. <i>b</i> # <i>s</i>	Sets digital output to ON	–
DIN# <i>s</i>	Returns a bit-weighted integer number based on the state of the DIO pins; the command looks at the raw state of the pins (input or output); if all are inactive, it returns 0; if all are active, it returns 15	–

Valid bit values (*b*) are 1-4; For commands ending with #*s*, *s* is the slot assigned to the digital I/O (0); Slot 0 is onboard

Table 9-14. Digital I/O Commands

## 9.15 Weigh Mode Commands

These commands function in the weigh mode. Non-weight-related commands work in setup mode.

Command	Description	Values
P	Returns what the indicator is currently displaying	–
ZZ	Returns what is currently displayed by the indicator, along with an integer number representing the currently displayed annunciators	See <a href="#">Section 11.2 on page 63</a>
S	Returns a single stream frame from the current scale using the configured string format	–
RS	Resets system	Soft reset; Used to reset the indicator without resetting the configuration to the factory defaults
SX	Starts all serial data streams	–
EX	Stops all serial data streams	–
SX# <i>p</i>	Starts serial data stream for port <i>p</i>	OK or ??
EX# <i>p</i>	Stops serial data stream for port <i>p</i>	An EX command sent while in setup mode does not take effect until the indicator is returned to weigh mode
SF# <i>n</i>	Returns a single stream frame from scale <i>n</i> using the configured string format	–
XG# <i>n</i>	Returns the gross weight in displayed units	nnnnnnnnn UU
XGP# <i>n</i>	Returns the gross weight in primary units	
XGS# <i>n</i>	Returns the gross weight in secondary units	

For commands ending with #*n*, *n* is the scale number (1); For commands ending with #*p*, *p* is the serial port number (1-2)

Table 9-15. Weigh Mode Commands

## 10.0 Maintenance

The maintenance information in this manual is designed to cover aspects of maintaining and troubleshooting the Tracer AV2. Contact the local Rice Lake Weighing Systems dealer if a problem requires technical assistance.



**NOTE:** Have the scale model number and serial number available when calling for assistance.

### 10.1 Maintenance Checkpoints

The scale must be checked frequently to determine when a calibration is required. It is recommended a zero calibration be checked every other day and a calibration checked every week for several months after installation. Observe the results and change the period between calibration checks, depending upon the accuracy desired.



**NOTE:** Establish a routine inspection procedure. Report changes in the scale function to the individual or department responsible for the scales' performance.

### 10.2 Field Wiring

If a problem with the wiring is suspected, check the electrical portion of the scale.

- Check for proper interconnections between the components of the system
- Check wiring meets all specifications in the installation drawings
- Check all wiring and connections for continuity, shorts and grounds using an ohmmeter with the scale off
- Check for loose connections, poor solder joints, shorted or broken wires and unspecified grounds in wiring; these issues cause erratic readings and shifts in weight readings
- Check all cable shields to ensure grounding is made at only the locations specified in the installation drawings

### 10.3 Troubleshooting Tips

Table 10-1 lists general troubleshooting tips for hardware and software error conditions

Symptom	Possible Cause	Remedy
Tracer AV2 does not power up	Bad power supply	Check power supply; Check presence of AC or DC power – breaker tripped or unit unplugged; Power supply outputs around 12 VDC – replace if bad
Battery backed corrupt error message at startup	Dead battery	Perform configuration reset then check for low battery warning on display; If battery is low, replace battery, perform another configuration reset, then reload files/configuration
##### or #####	Over or under range scale condition	Check scale; For out-of-range conditions in total scale display, check all scale inputs for positive weight values
Cannot enter setup mode	Bad switch	Test switch
Serial port not responding	Configuration error	Ensure port INPUT parameter is set to CMD for command input
A/D scale out of range	Scale operation Load cell connection Bad load cell	Check source scale for proper mechanical operation Check load cell and cable connection Check Tracer AV2 operation with load cell simulator Check status of sense settings

Table 10-1. Basic Troubleshooting

## 11.0 Appendix

### 11.1 Error Messages

The Tracer AV2 provides a number of error messages. When an error occurs, the message appears on the display.

#### 11.1.1 Displayed Error Messages

The Tracer AV2 provides a number of front panel error messages to assist in problem diagnosis. [Table 11-1](#) lists these messages and their meanings.

Error Message	Description
-----	Overflow error – Weight value too large to be displayed
nnnnnnnn	Gross > overload limit – Gross value exceeds overload limit; Check configuration or signal input level; Overload can be caused by input signal > 45 mV or common mode voltage > 950 mV
uuuuuuuu	Gross < underload limit – Gross value exceeds underload limit
INITIAL ZERO FAILED	Scrolls across display when an attempt to perform an initial zero fails, only possible at startup
PLEASE CAL	Scrolls across display when calibrating
OVERWEIGHT	Displays when the weight on the scale exceeds the alarm weight value; See <a href="#">Section 4.4.7 on page 37</a> to set text

Table 11-1. Error Messages

### 11.2 ZZ EDP Command

The ZZ command can be used to remotely query what is currently on the display of the Tracer AV2. The ZZ command returns what is currently displayed by the indicator, along with a number representing the currently lit annunciators ([Table 11-2](#)).

*Example: If the annunciator status value returned on the ZZ command is 145, the gross, standstill and lb annunciators are lit. The number 145 represents the sum of the values for the gross mode annunciator (16), the standstill annunciator (128) and the lb annunciator (1).*

Decimal Value	Annunciator
1	lb/primary units
2	kg/secondary units
4	—
8	—
16	Gross
32	—
64	Center of zer
128	Standstill

Table 11-2. Status Codes Returned on the ZZ Command



**NOTE:** Tracer AV2 does not return values 4, 8 or 32.

### 11.3 Audit Trail Support

Audit trail support provides tracking information for configuration and calibration events. To prevent potential misuse, all configuration and calibration changes are counted as change events.

Audit trail information can be printed from Revolution or by sending the DUMPAUDIT serial command. Revolution can be used to display audit trail information. The audit trail display includes the legally relevant (LR) version number (firmware version for the code which provides audit trail information), a calibration count and a configuration count.

See [Section 3.4.6 on page 26](#) for steps to view the Audit Trail counters with the Tracer AV2 display.

## 11.4 Conversion Factors for Secondary Units

The Tracer AV2 has the capability to mathematically convert a weight between pounds and kilograms and instantly display those results with a press of the **UNITS** key.

Primary and secondary units can be specified in the Format menu ([Section 4.4.2.1 on page 31](#)).



**NOTE:** Multipliers are preconfigured within the indicator.

Ensure the secondary decimal point position is set appropriately for the scale capacity in the secondary units.

## 11.5 Continuous Data (Stream) Output Formats

When the trigger setting for a port is set to STRIND or STRLFT, data is continuously streamed from the appropriate port in one of the four fixed format options or a custom format option.

### Fixed Format Options:

- Rice Lake Weighing Systems ([Section 11.5.1](#))
- Cardinal ([Section 11.5.2](#))
- Avery Weigh-Tronix ([Section 11.5.3 on page 65](#))
- Mettler Toledo ([Section 11.5.4 on page 66](#))

### 11.5.1 Rice Lake Weighing Systems Stream Format (rL5)

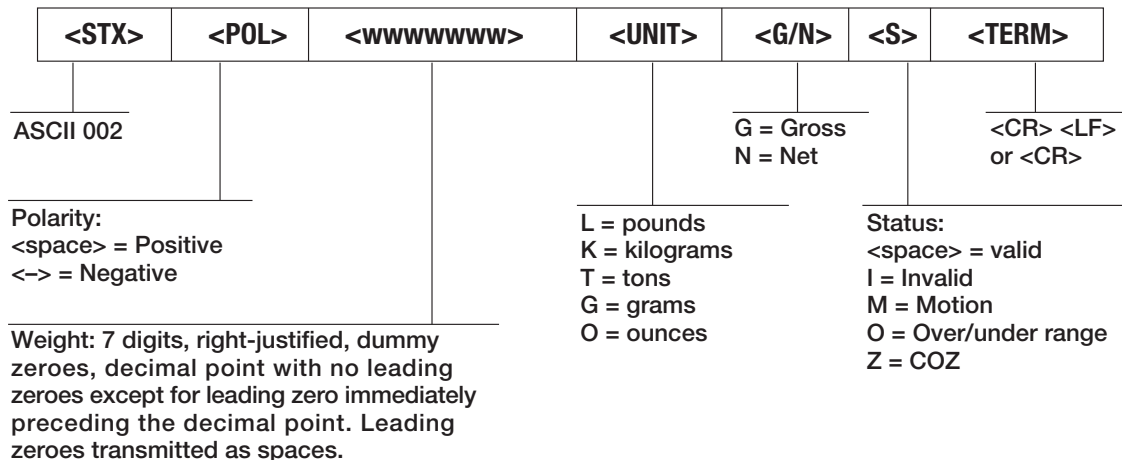

Figure 11-1. Rice Lake Weighing Systems Stream Data Format



### 11.5.2 Cardinal Stream Format (CARDL)

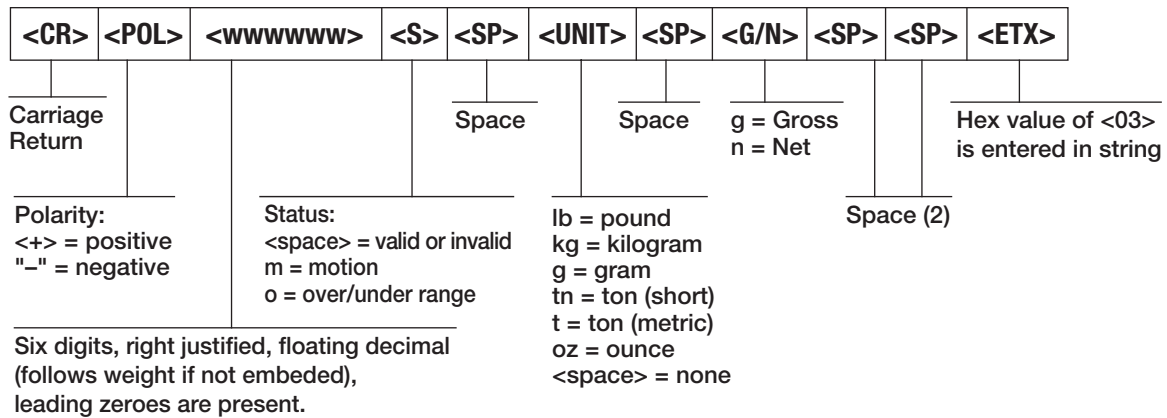

Figure 11-2. Cardinal Stream Data Format

### 11.5.3 Avery Weigh-Tronix Stream Format (AVERY)

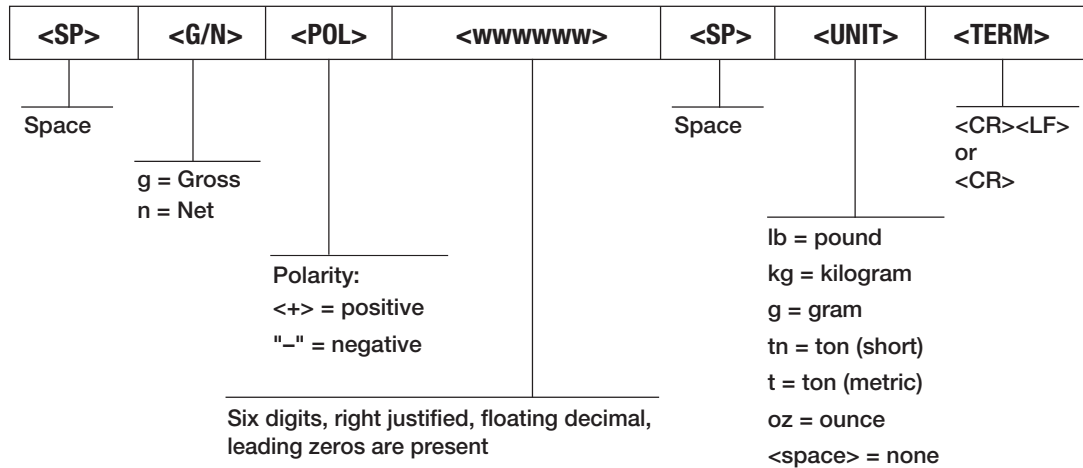

Figure 11-3. Avery Weigh-Tronix Stream Data Format

### 11.5.4 Mettler Toledo Stream Format (L0LEd0)

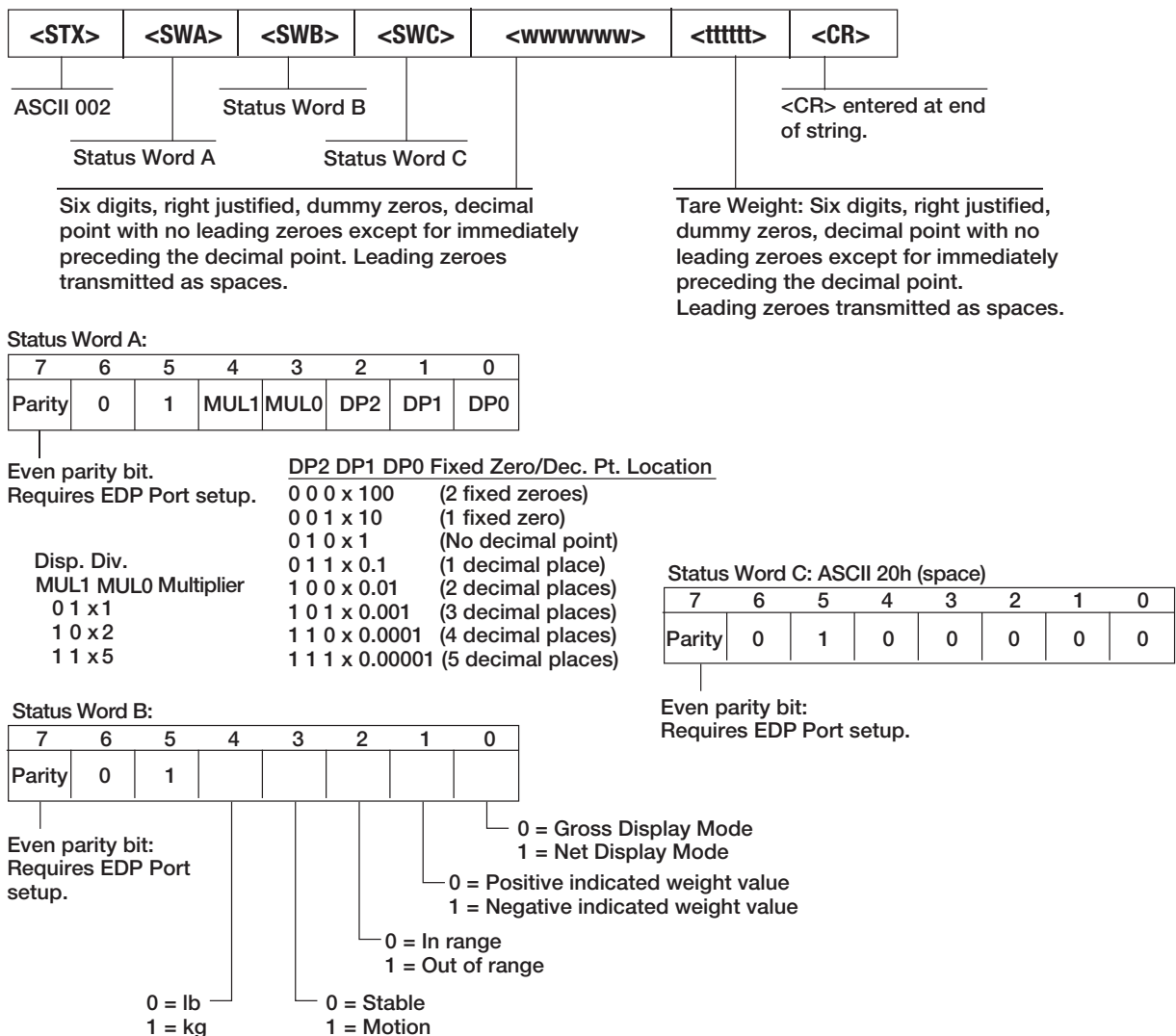

Figure 11-4. Mettler Toledo Stream Data Format

## 11.6 Digital Filtering

Digital filtering is used to create a stable scale reading in challenging environments. The Tracer AV2 allows selection of **Digital Rolling Average Filtering** (Section 11.6.1), **Adaptive Filtering** (Section 11.6.2 on page 67), **Damping** (Section 11.6.3 on page 68) or **None** (RAW) for no filtering. See Section 4.4.1 on page 30 for configuration menu layout and the location of FLTRCHN parameter.

The scale's sample rate effects all types of filtering. The A/D sample rate is selected by the SMPRAT scale parameter. The A/D sample rate is the number of weight readings the indicator takes per second (SMPRAT). This can be 6.25, 7.5, 12.5, 15, 25, 30, 50, 60 or 120 hertz (readings per second). Set the A/D sample rate to the lowest setting required for the application. Lower settings result in better stability.

### 11.6.1 Digital Rolling Average Filter (AVGONLY)

The digital rolling average filter uses mathematical averaging with three stages. These configurable stages control the effect of a single A/D reading on the displayed weight. When an A/D reading outside of a predetermined band is encountered, the digital rolling average filter is overridden and the display jumps directly to the new value.

### Digital Filter Stages (DGFLTR1-3)

The filter stages can each be set to a value of 1–256. The value assigned to each stage sets the number of readings received from the preceding filter stage before averaging. Setting the filter stages to 1 effectively disables the rolling filter.

A rolling average is passed to successive filtering stages for an overall filtering effect which is effectively a weighted average of the product of the values assigned to the filter stages ( $DGFLTR1 \times DGFLTR2 \times DGFLTR3$ ) within a time frame corresponding to the sum of the values ( $DGFLTR1 + DGFLTR2 + DGFLTR3$ ).

### Digital Filter Sensitivity (DFSENS) and Threshold (DFTHR)

The rolling averaging filter can be used by itself to eliminate vibration effects, but heavy filtering also increases settling time. The *DFSENS* and *DFTHR* parameters can be used to temporarily override filter averaging and improve settling time.

- *DFSENS* specifies the number of consecutive A/D readings which must fall outside the filter threshold (*DFTHR*) before filtering is suspended
- *DFTHR* sets a threshold value, in display divisions; When the specified number of consecutive A/D readings (*DFSENS*) fall outside of this threshold, filtering is suspended; Set *DFTHR* to *NONE* to turn off the filter override

### Digital Rolling Average Filter Procedure

1. In setup mode, set the rolling filter stage parameters (*DGFLTR1-3*) to 1.
2. Set *DFTHR* to *NONE*.
3. Return to weigh mode.
4. Remove all weight from scale, then watch the indicator to determine the magnitude of vibration effects on the scale.
5. Record weight below which all but a few readings fall. This value is used to calculate the *DFTHR* parameter in [step 8](#).  
*Example – if a heavy-capacity scale (10000 x 5 lb) produces vibration-related readings of up to 50 lb, with occasional spikes up to 75 lb, record 50 as the threshold weight value.*
6. Place the indicator in setup mode and set the filter stage parameters (*DGFLTR1-3*) to eliminate the vibration effects on the scale (leave *DFTHR* set to *NONE*).
7. Find the lowest effect value for the *DGFLTR1-3* parameters.

If needed, the digital filter cutout sensitivity (*DFSENS*) and the digital filter cutout threshold (*DFTHR*) can be used to reset the digital rolling average filter so the response to a rate change is faster.

8. Calculate the *DFTHR* parameter value by converting the weight value recorded in [step 5](#) to display divisions ( $\text{Threshold\_Weight\_Value} / \text{Display\_Divisions}$ ).  
*In the example in [step 5](#), with a threshold value of 50, and a display divisions value of 5, set the *DFTHR* parameter to 10 display divisions.*
9. Set the *DFSENS* parameter high enough to ignore transient peaks. Longer transients (typically caused by lower vibration frequencies) cause more consecutive out-of-band readings; set the *DFSENS* parameter higher to counter low frequency transients.

### 11.6.2 Adaptive Filter (ADPONLY)

The adaptive filter has two settings, sensitivity (*ADSENS*) and threshold (*ADTHR*). It maintains a running average of the A/D readings when the weight change remains less than the defined threshold value. The filter automatically applies less value to each successive A/D reading the longer the weight change is less than the threshold value. The amount of value given to the most recent A/D reading is determined by the sensitivity setting.

#### Adaptive Filter Sensitivity (ADSENS)

Adaptive filter sensitivity (*ADSENS*) can be set to *HEAVY*, *MEDIUM* or *LIGHT*. A *HEAVY* setting results in an output which is more stable to weight changes than the *LIGHT* setting. A *HEAVY* setting also results in small changes in weight data (a few grads) on the scale base to not be seen as quickly as with the *LIGHT* setting.

If the difference in typical subsequent weight values on the scale are only a few display divisions, use a *LIGHT* setting. On a truck scale where the changes in subsequent weight values are 100s of display divisions, a *HEAVY* setting is more appropriate.

### Adaptive Filter Threshold (ADTHRH)

Set the adaptive filtering threshold (*ADTHRH*) for the amount of observed instability in the system. This parameter can be set in the range of 0–2000 and is entered as a weight value. When a new sampled weight value is acquired, the adaptive filter compares the new value to the previous (filtered) output value.

If the difference between the new value and the previous output value is greater than the *ADTHRH* parameter the adaptive filter is reset to the new weight value.

If the difference between the new value and the previous output value is less than the *ADTHRH* parameter, the two values are averaged together using a weighted average. The weighted average is based on the amount of time the system has been stable, and selected *ADSENS* sensitivity.

With the adaptive filter threshold set at zero, determine the amount of instability present. Enter this amount of weight instability to set the threshold of the adaptive filter. The adaptive filter is set to *OFF*, the *ADTHRH* parameter is set to zero.

### 11.6.3 Damping Filter (DMPONLY)

The damping filter is a simple filter which adjusts the amount of time it takes for a change in weight to be processed through the scale. The *DAMPVAL* parameter is a time interval specified in tenths of a second (10 = 1 second). This damping value is used to determine the amount of time it takes for the scale to reach its final weight output. When *DAMPVAL* is set to ten, a transition from 0 lb to 500 lb on the scale takes one second. The closer the weight gets to its final amount, the slower the weight changes on the display.

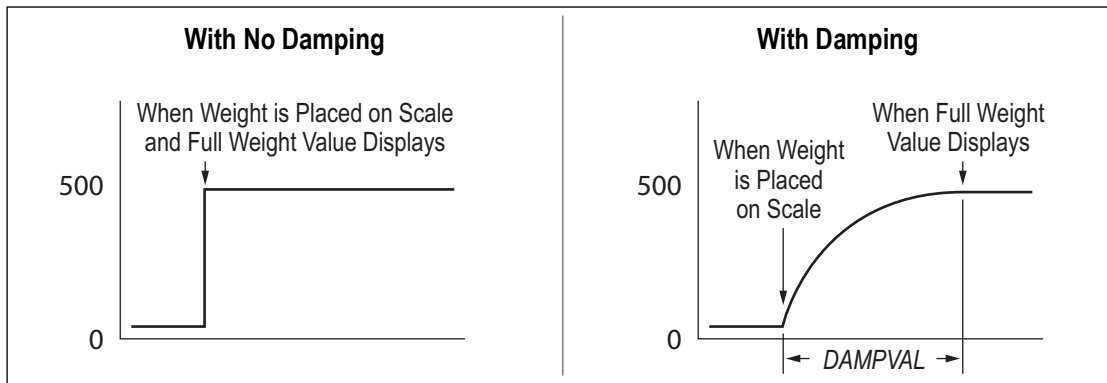

Figure 11-5. 500 lb Displayed Weight Progression

## 11.7 ASCII Character Chart

Use the decimal values for ASCII characters listed in [Table 11-3](#) when specifying alphanumeric strings in the Tracer AV2 menu. The actual character printed depends on the character mapping used by the output device.

The Tracer AV2 can send or receive ASCII character values (decimal 0–255), but displays are limited to numbers, uppercase, unaccented letters and a few special characters. See [Section 11.8 on page 70](#) for information about the display characters.

Control	ASCII	Dec	Hex	ASCII	Dec	Hex	ASCII	Dec	Hex	ASCII	Dec	Hex
Ctrl-@	NUL	00	00	space	32	20	@	64	40	`	96	60
Ctrl-A	SOH	01	01	!	33	21	A	65	41	a	97	61
Ctrl-B	STX	02	02	"	34	22	B	66	42	b	98	62
Ctrl-C	ETX	03	03	#	35	23	C	67	43	c	99	63
Ctrl-D	EOT	04	04	\$	36	24	D	68	44	d	100	64
Ctrl-E	ENQ	05	05	%	37	25	E	69	45	e	101	65
Ctrl-F	ACK	06	06	&	38	26	F	70	46	f	102	66
Ctrl-G	BEL	07	07	'	39	27	G	71	47	g	103	67
Ctrl-H	BS	08	08	(	40	28	H	72	48	h	104	68
Ctrl-I	HT	09	09	)	41	29	I	73	49	i	105	69
Ctrl-J	LF	10	0A	*	42	2A	J	74	4A	j	106	6A
Ctrl-K	VT	11	0B	+	43	2B	K	75	4B	k	107	6B
Ctrl-L	FF	12	0C	,	44	2C	L	76	4C	l	108	6C
Ctrl-M	CR	13	0D	-	45	2D	M	77	4D	m	109	6D
Ctrl-N	SO	14	0E	.	46	2E	N	78	4E	n	110	6E
Ctrl-O	SI	15	0F	/	47	2F	O	79	4F	o	111	6F
Ctrl-P	DLE	16	10	0	48	30	P	80	50	p	112	70
Ctrl-Q	DC1	17	11	1	49	31	Q	81	51	q	113	71
Ctrl-R	DC2	18	12	2	50	32	R	82	52	r	114	72
Ctrl-S	DC3	19	13	3	51	33	S	83	53	s	115	73
Ctrl-T	DC4	20	14	4	52	34	T	84	54	t	116	74
Ctrl-U	NAK	21	15	5	53	35	U	85	55	u	117	75
Ctrl-V	SYN	22	16	6	54	36	V	86	56	v	118	76
Ctrl-W	ETB	23	17	7	55	37	W	87	57	w	119	77
Ctrl-X	CAN	24	18	8	56	38	X	88	58	x	120	78
Ctrl-Y	EM	25	19	9	57	39	Y	89	59	y	121	79
Ctrl-Z	SUB	26	1A	:	58	3A	Z	90	5A	z	122	7A
Ctrl-[	ESC	27	1B	;	59	3B	[	91	5B	{	123	7B
Ctrl-\	FS	28	1C	<	60	3C	\	92	5C		124	7C
Ctrl-]	GS	29	1D	=	61	3D	]	93	5D	}	125	7D
Ctrl-^	RS	30	1E	>	62	3E	^	94	5E	~	126	7E
Ctrl-_	US	31	1F	?	63	3F	_	95	5F	DEL	127	7F

Table 11-3. ASCII Character Chart

## 11.8 Front Panel Display Characters

Refer to [Figure 11-6](#) for the seven-segment LED character set used on the front panel display for alphanumeric characters.

!		7		Ff		Ss	
"		8		Gg		Tt	
+		9		Hh		Uu	
-		:		li		Vv	
.		;		Jj		Ww	
/		<		Kk		Xx	
0		=		Ll		Yy	
1		>		Mm		Zz	
2		Aa		Nn		[	
3		Bb		Oo		\	
4		Cc		Pp		]	
5		Dd		Qq		_	
6		Ee		Rr			

Figure 11-6. Display Characters

## 12.0 Specifications

### Display

Stainless steel, panel mounted, LCD display  
Seven 0.8 in (20 mm) tall, seven-segment digits

### Operator Keypad

Stainless steel, panel mounted  
Five keys: Zero, Units, Enter, Print, Accum

### A/D Sample Rate

6.25–120 Hz, software selectable

### Voltage Input

Controller box: 7.5 VDC, 4.0 A  
External power supply: 100–240 VAC, 47–63 Hz, 0.93 A

### Power Consumption:

6 W (current is ~2 W with one 350 $\Omega$  load cell connected)

### Communication Ports

RS-232 full duplex to host, up to 115.2 kbps,  
data seven odd, seven even, eight none  
Wi-Fi or Bluetooth® configurable (see [Section 6.5 on page 50](#) and  
[Section 7.2 on page 53](#) for wireless module specifications)  
Ethernet TCP/IP  
Micro USB (device)

### Remote Display Ports

RS-232 receive simplex, 19.2 kbps, data eight none  
Input: 7.5 VDC

### Load Cell Excitation

5 VDC

### Analog Signal Input Range

-0.5 mV/V to +4.5 mV/V

### Dimensions (W x H x D)

CPU enclosure: 8.9 x 7.3 x 2.4 in  
(without mounting feet) (22.61 x 18.55 x 6.10 cm)  
CPU enclosure: 11.1 x 7.3 x 3.2 in  
(with mounting feet) (28.20 x 18.55 x 8.13 cm)  
Panel mount keypad: 4.0\* x 2.5 x 2.1 in [\*4.63 with bracket]  
(10.16\* x 6.35 x 5.33 cm) [\*11.76]  
Panel mount display: 7.5 x 4.0 x 1.49 in  
(19.05 x 10.16 x 3.79 cm)  
Extended mount display: 7.5 x 3.9 x 1.44 in  
(19.05 x 9.91 x 3.66 cm)

### Weight

5.25 lb (2.38 kg)

### Environmental

Temperature range: 14–104°F (-10–40°C)  
Recommended use: Indoor only  
Pollution degree: 2  
Operating altitude: 2,000 m  
Relative humidity: 0% to 95%, non-condensing  
operating and storage

### Warranty

Two-year limited warranty

### Certifications and Approvals



#### NTEP

CoC Number: 21-015  
Accuracy Class: III/IIIL;  $n_{max}$ : 10 000



#### Measurement Canada

Approval: AM-6168C  
Accuracy Class: III;  $n_{max}$ : 10 000



#### UL

cULus Marked









© Rice Lake Weighing Systems Content subject to change without notice.

230 W. Coleman St. • Rice Lake, WI 54868 • USA USA: 800-472-6703 • International: +1-715-234-9171