

# TuffSeal®

*Heavy Capacity Junction Box  
JB8SP*

## Installation Manual



**RICE LAKE**  
WEIGHING SYSTEMS

PN 174208 Rev A

An ISO 9001 registered company  
© Rice Lake Weighing Systems. All rights reserved.

Rice Lake Weighing Systems® is a registered trademark of  
Rice Lake Weighing Systems.

All other brand or product names within this publication are trademarks or  
registered trademarks of their respective companies.

All information contained within this publication is, to the best of our knowledge, complete  
and accurate at the time of publication. Rice Lake Weighing Systems reserves the right to  
make changes to the technology, features, specifications and design of the equipment  
without notice.

The most current version of this publication, software, firmware and all other product  
updates can be found on our website:

**[www.ricelake.com](http://www.ricelake.com)**

# Contents

---

<b>1.0</b>	<b>Introduction</b> .....	<b>1</b>
	1.1 Safety .....	2
	1.2 Special Conditions of Use .....	2
<b>2.0</b>	<b>TuffSeal Junction Box Installation</b> .....	<b>3</b>
<b>3.0</b>	<b>Wiring the Junction Box</b> .....	<b>4</b>
<b>4.0</b>	<b>Trimming Procedure</b> .....	<b>6</b>



*Technical training seminars are available through Rice Lake Weighing Systems. Course descriptions and dates can be viewed at [www.ricelake.com/training](http://www.ricelake.com/training) or obtained by calling 715-234-9171 and asking for the training department.*

© Rice Lake Weighing Systems. All rights reserved. Printed in the United States of America.  
Specifications subject to change without notice.  
Rice Lake Weighing Systems is an ISO 9001 registered company.  
June 7, 2017



*Rice Lake continually offers web-based video training on a growing selection of product-related topics at no cost. Visit [www.ricelake.com/webinars](http://www.ricelake.com/webinars)*

# 1.0 Introduction

---

The *TuffSeal*® eight-channel signal trim junction box can accommodate up to eight load cells and is used in NTEP required truck scale installations. Additional load cells can be accommodated by wiring multiple junction boxes using the expansion terminal located on the main board.

The junction box has a Prevent® breather vent which inhibits the buildup of pressure caused by sudden temperature or environmental changes. The breather vent inhibits the buildup of pressure caused by sudden temperature or environmental changes. It should be changed every six months to a year as it will become dirty over time. When correctly installed and torqued to 10 lb/in, all models can withstand 900 PSI water pressure.

The *TuffSeal* junction box will function properly without modification. If needed, load cell output can be individually trimmed with potentiometers. For more information, see Section 4.0 on page 6.



Manuals can be viewed or downloaded from the Rice Lake Weighing Systems website at [www.ricelake.com/manuals](http://www.ricelake.com/manuals)

Warranty information can be found on the website at [www.ricelake.com/warranties](http://www.ricelake.com/warranties)



*Figure 1-1. TuffSeal Truck Scale Junction Box*

## 1.1 Safety

### Safety Signal Definitions:



**DANGER** Indicates an imminently hazardous situation that, if not avoided, will result in death or serious injury. Includes hazards that are exposed when guards are removed.



**WARNING** Indicates a potentially hazardous situation that, if not avoided could result in serious injury or death. Includes hazards that are exposed when guards are removed.



**CAUTION** Indicates a potentially hazardous situation that, if not avoided, could result in minor or moderate injury.



**Important** Indicates information about procedures that, if not observed, could result in damage to equipment or corruption to and loss of data.

---

### General Safety

---



Do not operate or work on this equipment unless this manual has been read and all instructions are understood. Failure to follow the instructions or heed the warnings could result in injury or death. Contact any Rice Lake Weighing Systems dealer for replacement manuals.



Failure to heed may result in serious injury or death.



Do not install where water may accumulate; this could cause electric shock and damage to the unit.

Do not use if wiring is frayed or worn.

Do not use if the cover is off or the unit has not been sealed properly.

Do not place fingers into slots or possible pinch points.

Do not use this product if any of the components are cracked.

Do not make alterations or modifications to the unit.

Do not remove or obscure warning labels.

Ensure load cells are correctly wired; incorrect wiring could cause damage to the unit.

## 1.2 Special Conditions of Use

- Clean the J-Box enclosure with a damp cloth only - Electrostatic Charging Hazard.
- This equipment was examined and approved for connection to a single Indicator only.

## 2.0 TuffSeal Junction Box Installation

The *TuffSeal* junction box should be mounted in a location that is convenient for servicing and away from standing water. Mount the enclosure in a location so that the load cell cable need not be cut, nor length added. Load cell output is temperature compensated for the supplied cable length; altering the cable length can change the cell's signal output.

Depending on the mounting surface, the enclosure is attached using four pan-head screws, bolts or other suitable fasteners (not included). [Figure 2-1](#) shows the dimensions for mounting the enclosure.

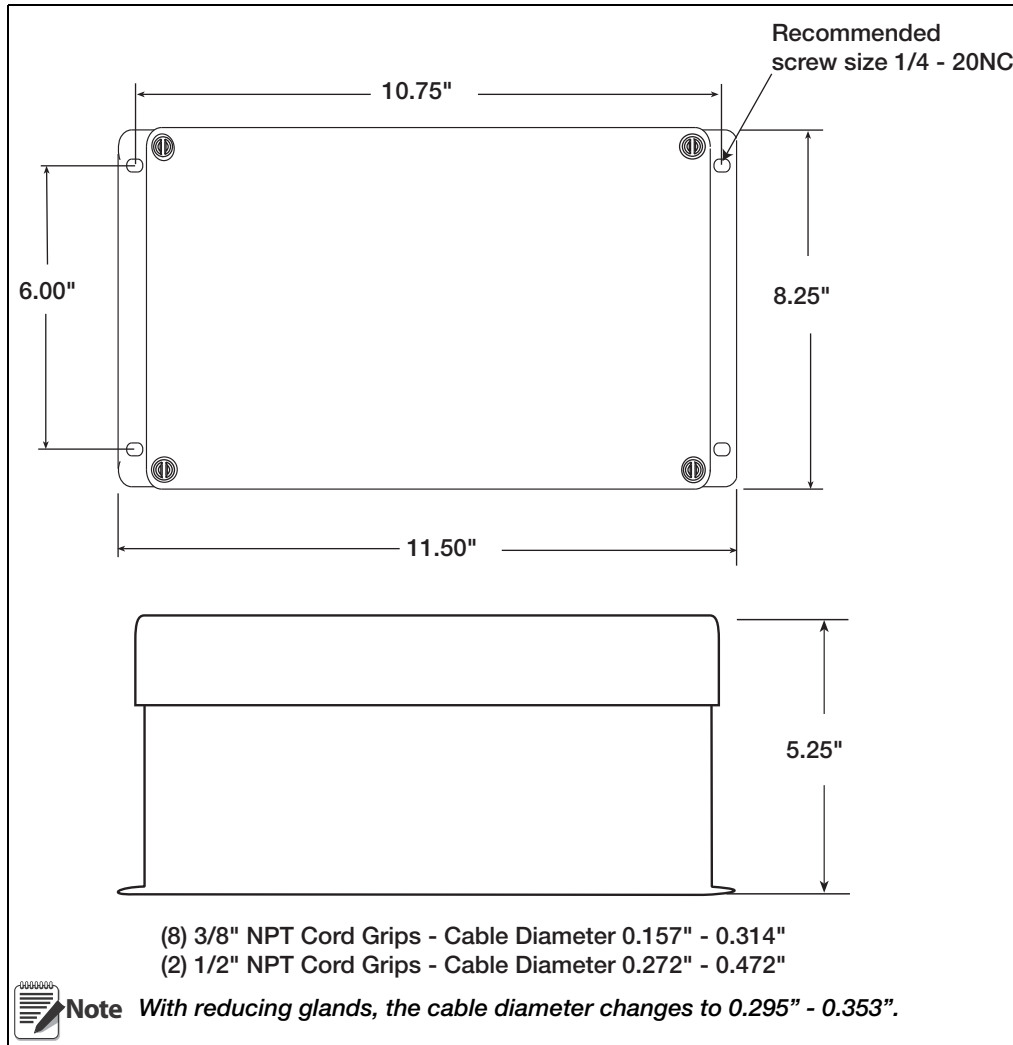

Figure 2-1. JB8SP Enclosure Dimensions

## 3.0 Wiring the Junction Box

The *TuffSeal* junction box is designed to connect and trim up to eight load cells per board. However, it is possible to use this box with two, four, six and eight load cell combinations. Use the expansion port on the main board to connect multiple junction boxes in series to accommodate applications having ten or more load cells.

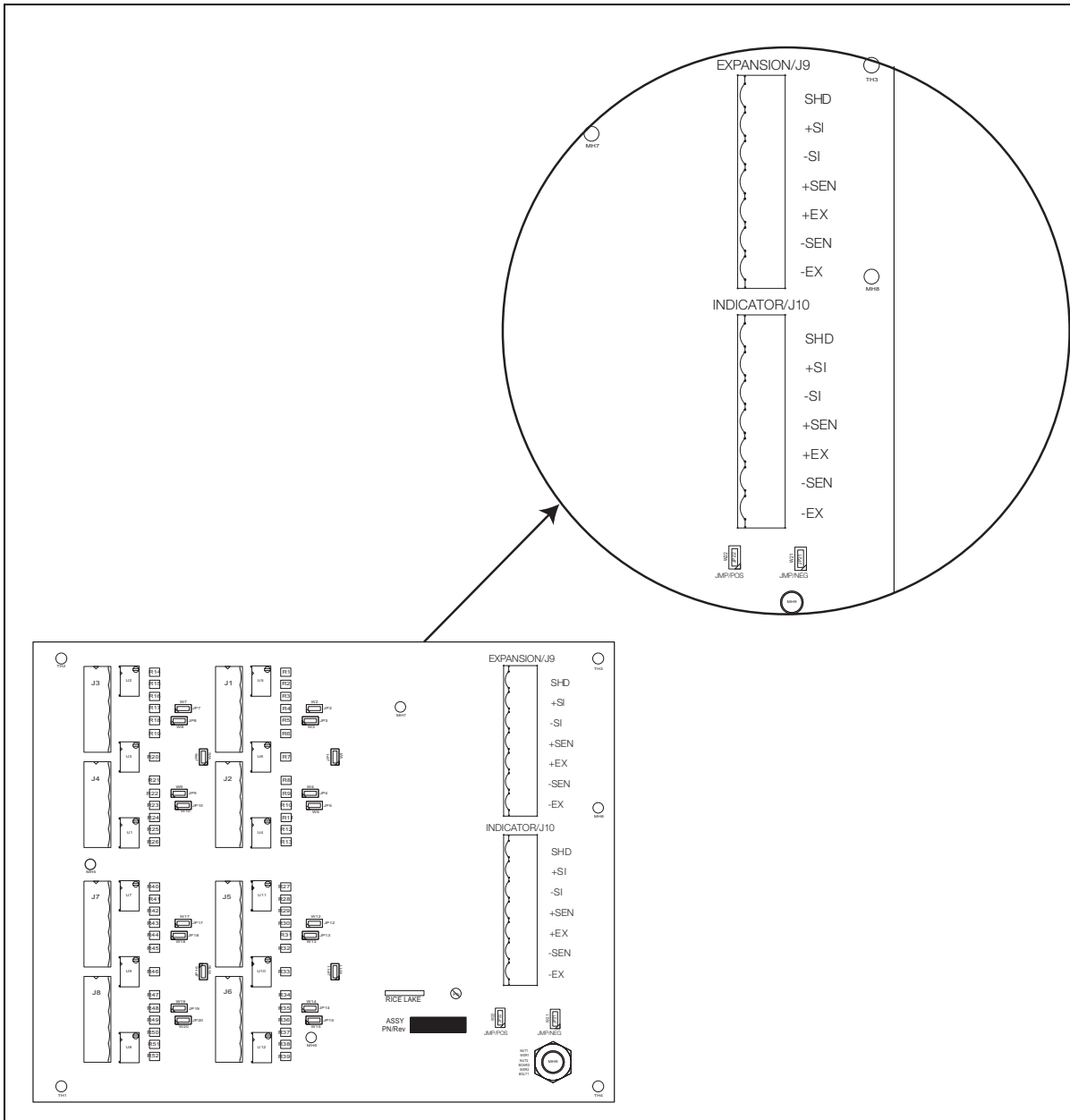

Figure 3-1. Expansion Port Wiring Location

1. Determine the wiring pattern, then route the load cell cables through the cord grip assemblies. Leave the grips loose until final closure.
2. Strip the wire insulation back 1/4" to expose the wire. The pluggable connector will accommodate 12 to 28 gauge wire.
3. Open each pole with a small screwdriver and insert the appropriate wire into the exposed wire opening.
4. Tighten the end screw with the screwdriver to secure each wire into place.
5. Plug the terminal to the appropriate header socket.



**Note** The indicator terminal is used to connect the main cable to the weight indicator. Determine the indicator's load cell input connections from the indicator manual.



6. Run a cable from the indicator terminal into the junction box through the larger cord grip.
7. Make the connections on the indicator terminal using the same procedure as inserting load cell cables to the appropriate connectors.



**Note** *If cables could be exposed to water or other liquids, bend a short downward loop in all cables near the cord grips so any fluids draining down the cables will drip off before reaching the junction box.*

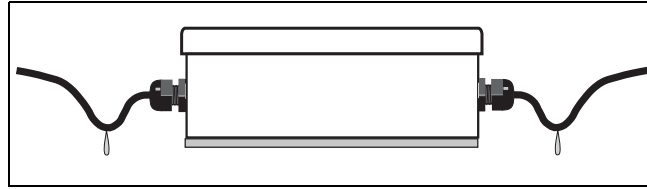

*Figure 3-2. Drip Loop Cable*

## 4.0 Trimming Procedure

---

Trimming is a process of equalizing the output from multiple individual load cells. If needed, load cell output can be individually trimmed with potentiometers.

When a substantial amount of trim (more than 7% of normal output), is necessary to equalize output, check for other possible problems. The best trim is always the least amount of trim.

The JB8SP is a signal trimming device with individual and section trimming potentiometers (see [Figure 4-1 on page 7](#)).

Use the following steps to properly trim the JB8SP junction box.



**Note** *If using two junction boxes with an expansion cable between them, make sure to cut the sense trace on the board that has the homerun cable connected to it (see [Figure 4-1 on page 7](#)). This ensures sensing out to the furthest junction box within the system. A six conductor cable must be used between the two junction boxes to ensure proper functioning of sense.*

1. Determine the number of load cells needed. When section trimming, it is acceptable to use combinations of load cells other than eight, but the combination must be an even number of cells.
2. Turn all the individual cell and section potentiometers clockwise to give maximum signal output from each section. Remove all shunt jumpers of the individual cells that are not used to disable them and ensure the section potentiometer is turned fully.



**Note** *If desired, all the potentiometers can be adjusted three to five full turns counter-clockwise to allow trim capabilities both positive and negative.*

3. Determine the lowest value and turn the potentiometers counter-clockwise to trim all other values to match the lowest value.
4. Remove all weight from the scale and zero the indicator. Place calibrated test weights over each load cell or section. The amount of test weights to be used will depend on the scale configuration. For specific recommendations, refer to the Handbook 44, published by the National Institute of Standards and Technology (NIST).
5. Record the value displayed on the indicator after the test weight is placed in turn over each load cell, or over each section. Select the load cell or section that has the lowest value as the reference point. This load cell or section will not be trimmed.
6. Place the same test load over each cell or section in turn. Using the corresponding potentiometer, trim each cell or section down to equal the reference point. Check zero after every adjustment to avoid zero shift, as load cell corrections are interactive.
7. Check load cells or sections again and repeat steps 6-8 as needed.

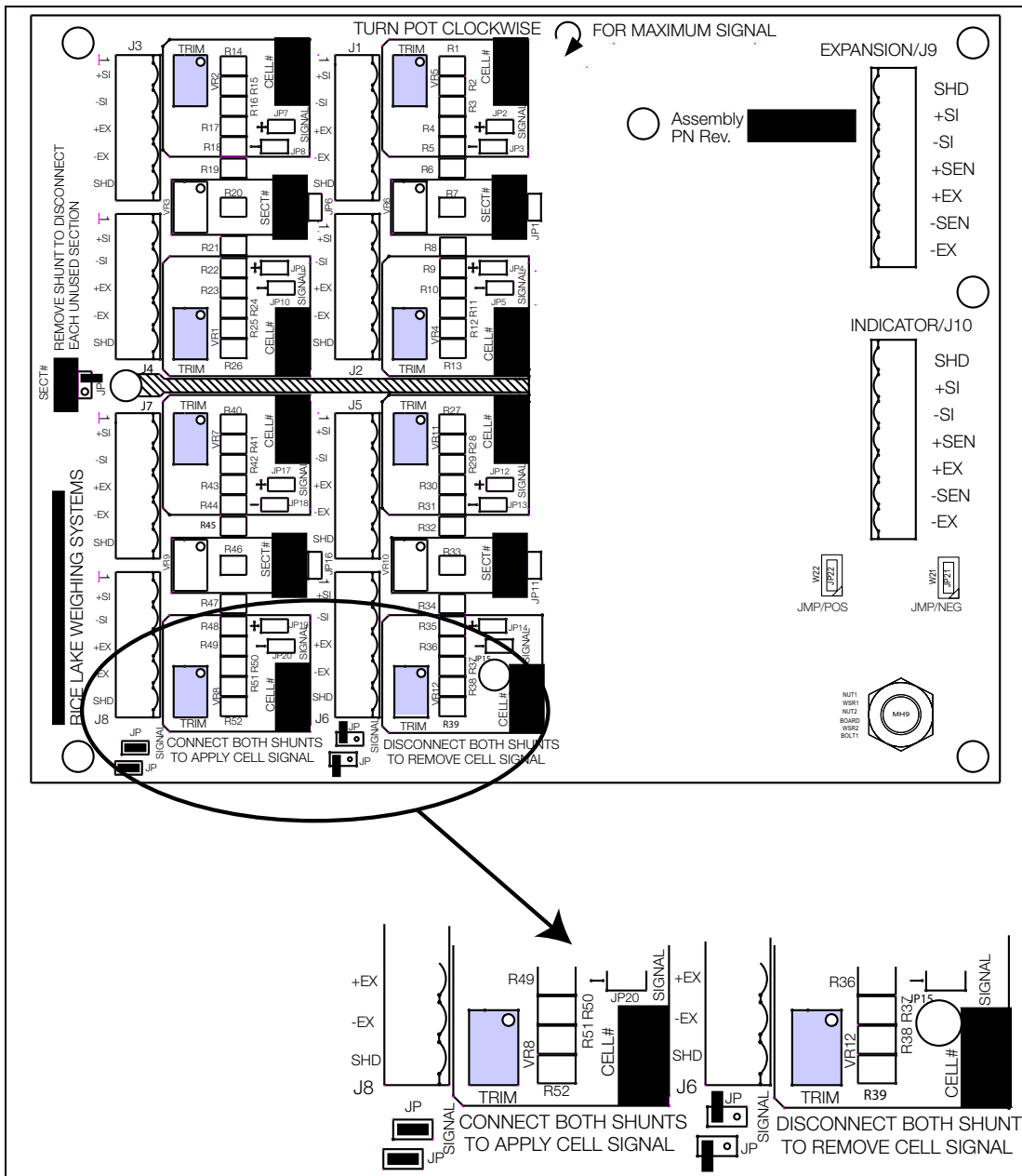

Figure 4-1. Shunt Locations

8. Pull excess cable out of the enclosure.
9. Using a wrench, tighten the nut until the rubber touches the cable completely.
10. Tighten the nut an additional half turn (180°). To be watertight, each cord grip must be tightened so the rubber sleeve begins to protrude from the hub.



**Note** Unused hubs must be properly plugged to prevent moisture entry. Extra hole plugs are provided to seal up any unused hubs.

11. Remove the desiccant from the plastic bag, and insert the desiccant bag into the junction box before closing. Inspect the desiccant during normal service and change as needed.
12. Replace the cover and torque the cover screws in an alternating pattern to 15 in-lb to be certain the gasket is compressed equally in all locations.







© Rice Lake Weighing Systems Specifications subject to change without notice.  
Rice Lake Weighing Systems is an ISO 9001 registered company.

230 W. Coleman St. • Rice Lake, WI 54868 • USA  
U.S. 800-472-6703 • Canada/Mexico 800-321-6703 • International 715-234-9171 • Europe +31 (0)26 472 1319

---

**[www.ricelake.com](http://www.ricelake.com)**