

Forklift Questionnaire



Dealer/Company Name _____ Contact Person _____

QUESTIONNAIRE

FORKLIFT SPECIFICATIONS

If the answer is no, please explain.

1. Is the lift a typical counterbalance forklift? Yes No _____
2. Does the forklift have an ITA type carriage? (clip/hook on style forks) Yes No _____
3. Is the carriage a Class II, 16" profile? Yes No _____
4. Is the carriage width greater than 36"? Yes No _____
5. Is the supply power 12 VDC? Yes No _____
6. Forklift capacity _____ 7. Mast Extension _____
8. Make _____ 9. Model _____

LOAD BACKSTOP

If the answer to any question below is no, please provide notes under Additional Comments.

10. Is there a load backstop present? Yes No
- If yes, please answer the next questions
- a. Is the backstop bolted to the side of the carriage? Yes No
- If yes, please complete Drawing #2
- b. Is the backstop bolted to the front of the carriage? Yes No
- If yes, please complete Drawing #3
11. Is this a cable-less application? Yes No
- If yes, please complete Drawing #4

ADDITIONAL COMMENTS

ATTACHMENTS

12. Are attachments present? Yes No

If yes, please list attachments below

Description _____

Make _____

Model _____

LEGAL FOR TRADE

13. Is NTEP required? Yes No
14. Is Measurement Canada required? Yes No
15. Is the fork length 42" or less? Yes No

INSTRUMENTATION

16. Select preferred instrumentation model CLS-680 CLS-920i Virtui3

Drawing #1

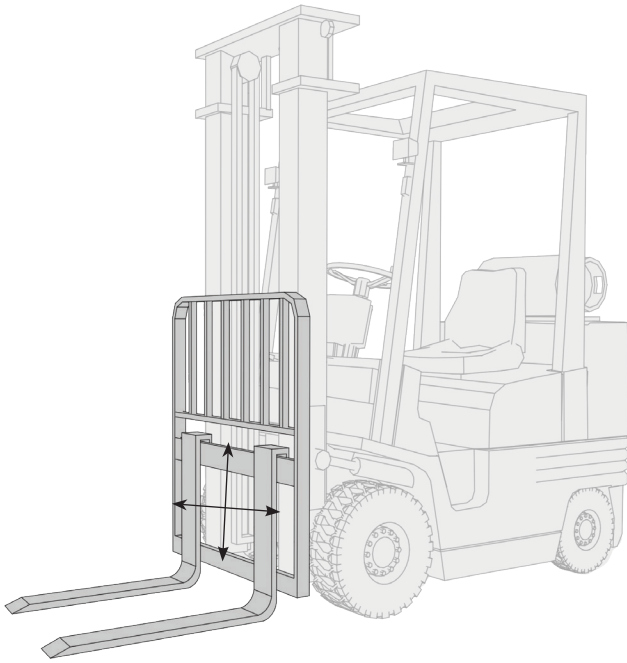

Horizontal Dimension

Vertical Dimension

Drawing #2

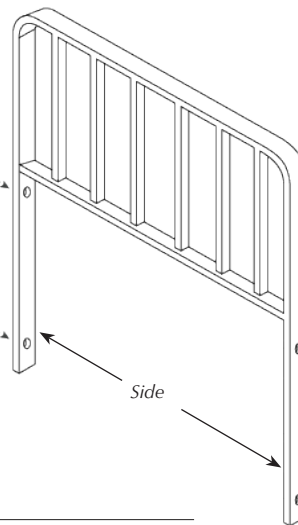

Dimension

Drawing #3

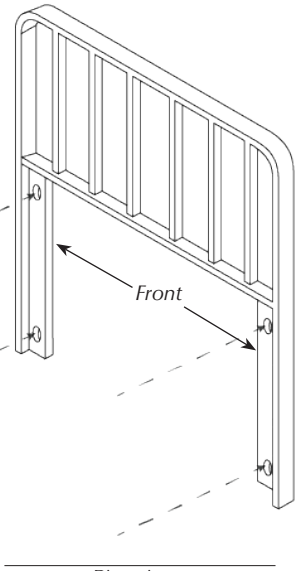

Dimension

Drawing #4

