

Rice Lake Freight Dimensioner Installation Questionnaire

This questionnaire will help Rice Lake Weighing Systems installers understand your site location in preparation for your upcoming dimensioner installation. Rice Lake installers carry hand tools only and will need assistance from existing onsite personnel should any fabrication or high voltage wiring need to occur. If this system will be installed outside the United States a letter of invitation will be needed before departure.

Are there any special safety training classes or onsite PPE requirements? Please describe: _____

1. Site Location:

Company Name: _____
RL Customer Number: _____
Street Address: _____
City, State, Zip: _____
Country: _____
Entry Door Location: _____

2. Contacts (please specify who the Rice Lake installer should call upon arrival):

Project Contact:

Name: _____
Title: _____
Email Address: _____
Phone Number: _____

Site Contact:

Name: _____
Title: _____
Email Address: _____
Phone Number: _____

IT Contact:

Name: _____
Title: _____
Email Address: _____
Phone Number: _____

3. Scale Integration:

When new or existing weighing equipment is integrated with a dimensioner it will require calibration. A certified local scale dealer will need to perform this. Rice Lake will contract your scale service provider that already takes care of your weighing equipment to arrange this service. Please provide scale company name and contact information: _____

4. Quality Assurance:

Rice lake installers will validate the accuracy and performance of your newly installed dimensioner and make any environmental adjustments that might be necessary. They will require a variety of freight examples and access to a forklift or driver to test the dimensioner. We allow for 4-6 hours for this process although it may be less than that.

5. Training and System Overview:

Rice Lake will provide training for the Terminal/Warehouse/IT Managers and any forklift drivers or operators that will be using the dimensioner. You will learn about the operator interface, general configuration menus, the calibration process, and how to test the dimensioner for accuracy. If this is your first dimensioner it is important to understand how the dimensioner works, what the best practices are and any conditions that will negatively affect dimensioning accuracy.

6. Best Practices:

- The dimensioner should not be installed near dock doors or areas of direct sunlight. Ensure light from an open dock door will not reach the dimensioner work area any time during the year.
- The dimensioning **work area** is reserved space centered under the dimensioner.
 - Flex dimensioner work area 9x9 feet.
 - LTL dimensioner work area 11x11 feet.
 - LTL XL dimensioner work area 15x11 feet.
- Reflective safety will adversely affect the dimensioner. When triggering the dimensioner employees should remain outside of the work area if wearing a reflective vest.
- No materials, debris, or scrap should be in the dimensioner work area to prevent items getting pulled into freight dimensions.
- Any bollards or barriers to protect the scale and dimensioner need to be installed outside the work area.
- Traffic cones and barrels with reflective stripes will adversely affect the dimensioner and need to remain outside the work area.
- Do not stack stretch-wrapped freight close to the work area. Reflections back into the work area from the stretch wrap can affect dimensioning accuracy.

7. Network:

One IP address is needed for the industrial computer; either DHCP with a reservation, or a static address. Because the DHCP IP address can change upon power cycle (without a reservation) Rice Lake strongly recommends a static address be used.

- Use DHCP , or Static IP address ?
- What data transfer protocol do you prefer (FTP, FTPS, SFTP, SMB*)? _____
*SMB requires iDim SS to be hosted on customer's server
- What is the preferred data format (CSV, XML, JSON, tab delimited TXT)? _____

What is the industrial computer's ...	What is the FTP server's ...
• IP address:	• IP address:
• Subnet mask:	• Port:
• Gateway address:	• Rice Lake login:
• Primary DNS address:	• Rice Lake password:
• Secondary DNS address:	• Path:

For proper support, Rice Lake requires TeamViewer be installed on the industrial computer and Rice Lake be given access to remote-in for support and troubleshooting if needed.

8. Customer Responsibilities:

- Provide pictures of the ceiling and floor at the proposed installation site. Send to iDim_Sales@ricelake.com along with a completed copy of this questionnaire.
- Provide a scissors lift with a minimum 500 pound capacity and ability to reach your ceiling height.
- Provide a 120VAC or (240VAC Europe) duplex outlet within 20 feet of the dimensioner.
- Describe mounting location for the industrial touchscreen computer. Computer and Ram mount will be included in your quote. (wall, pillar, desk)

- Provide mounting hardware requirements for computer Ram mount: screws, bolts, mollies or lags depending on the type of surface being mounted to.

- Provide RJ45 Ethernet connection drop to company network within 20 feet of dimensioner. Please specify connector gender. _____

- Provide several freight samples that can be used for training and dimensioner evaluation after installation. Freight samples should represent your typical freight including the largest and smallest that fit within the dimensioner's measurement capabilities.
- Rice Lake will provide short runs of Ethernet cable between the industrial touchscreen computer and the dimensioner (20 feet or less). If the industrial touchscreen computer is installed in an office, or not within viewing distance, the customer is responsible for supplying and running the Ethernet cable.

Building Site Installation:

An LTL dimensioner is installed at 132 inches above the floor ± 1 inch. If installing over a conveyor or pallet stretch wrapper, the “floor” is the top of the turntable or top of the conveyor. An area on the floor directly below the dimensioner should be reserved as the dimensioning work area and be kept free of any objects except the object being dimensioned. The dimensioner will be suspended from the ceiling with either an onsite custom-built 80/20 frame or with aircraft grade stainless cables. We can install directly to the primary I-beam roof rafter or from secondary Z-channel roof perlin. To assist the installer please provide the measurements requested in preparation for a smooth installation.

Refer to the diagram below to help answer the following questions:

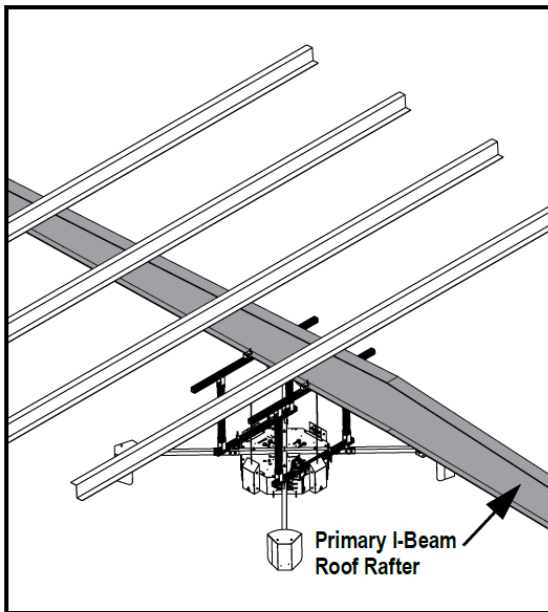

Primary I-Beam Rafter Configuration

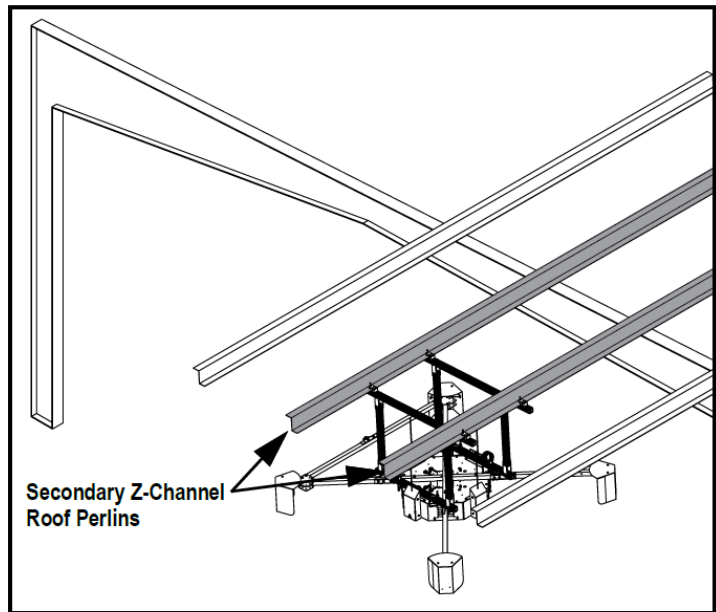

Secondary Z-Channel Roof Perlin Configuration

1. If your ceiling is flat, what is the height from the floor to the bottom of main and support beams H1? _____ inches/centimeters.
2. If the ceiling is pitched, provide two height measurements to bottom of main beam and the dimension between them. Measurement 1 _____, Measurement 2 _____, Distance between them _____. This will allow us to calculate the pitch (slope) of the roof.
3. What are distances between main beams? Include any not evenly spaced? _____

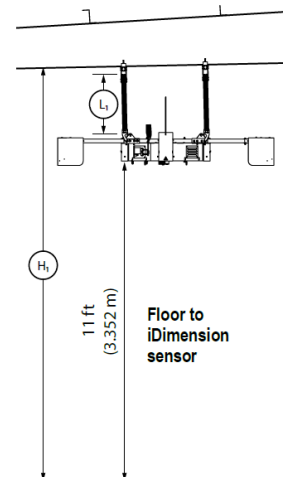

Note: If your ceiling is greater than 25 feet high, aircraft grade cables will be used to install the dimensioner.

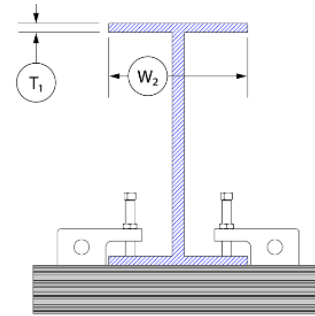
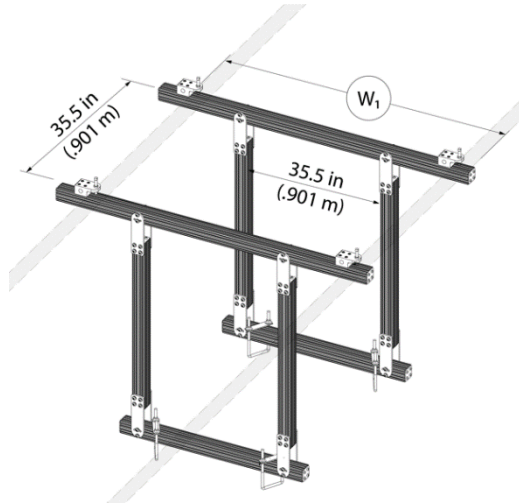

* 8020 hanging assembly shown clamped to I-Beam

4. What is the distance between Z-channel perlins W_1 ? _____
5. What type of material is each kind of beam (e.g. steel, wood, concrete)? _____
6. For any I-beams or Z-channel, what is the width of the beam flange W_2 , and thickness of the flange T_1 ? _____
7. Are there any obstructions that might prevent the installation of the dimensioner? (lights, sprinkler pipes, HVAC etc.) _____
8. What is the height from the floor to the bottom of the obstruction, and their height (bottom to top)?

9. What is the distance from the obstruction to the beams?

NOTES: Please tell us anything else that you feel we should know about your site: _____
